

Зип Общепит

DESPIECES DEL SERVICIO TECNICO

+7(812)987-08-81
LAVAVAJILLAS - LAVÉVAISSELLE
DISHWASHERS - GESCHIRRSPÜLER
LAVASTOVIGLIE

Modelos

FI-48 FI-48 B

FI-64 FI-64 B

DICIEMBRE 2000



Fagor Industrial

Зип Общепит

vsezip.ru

+7(812)987-08-81

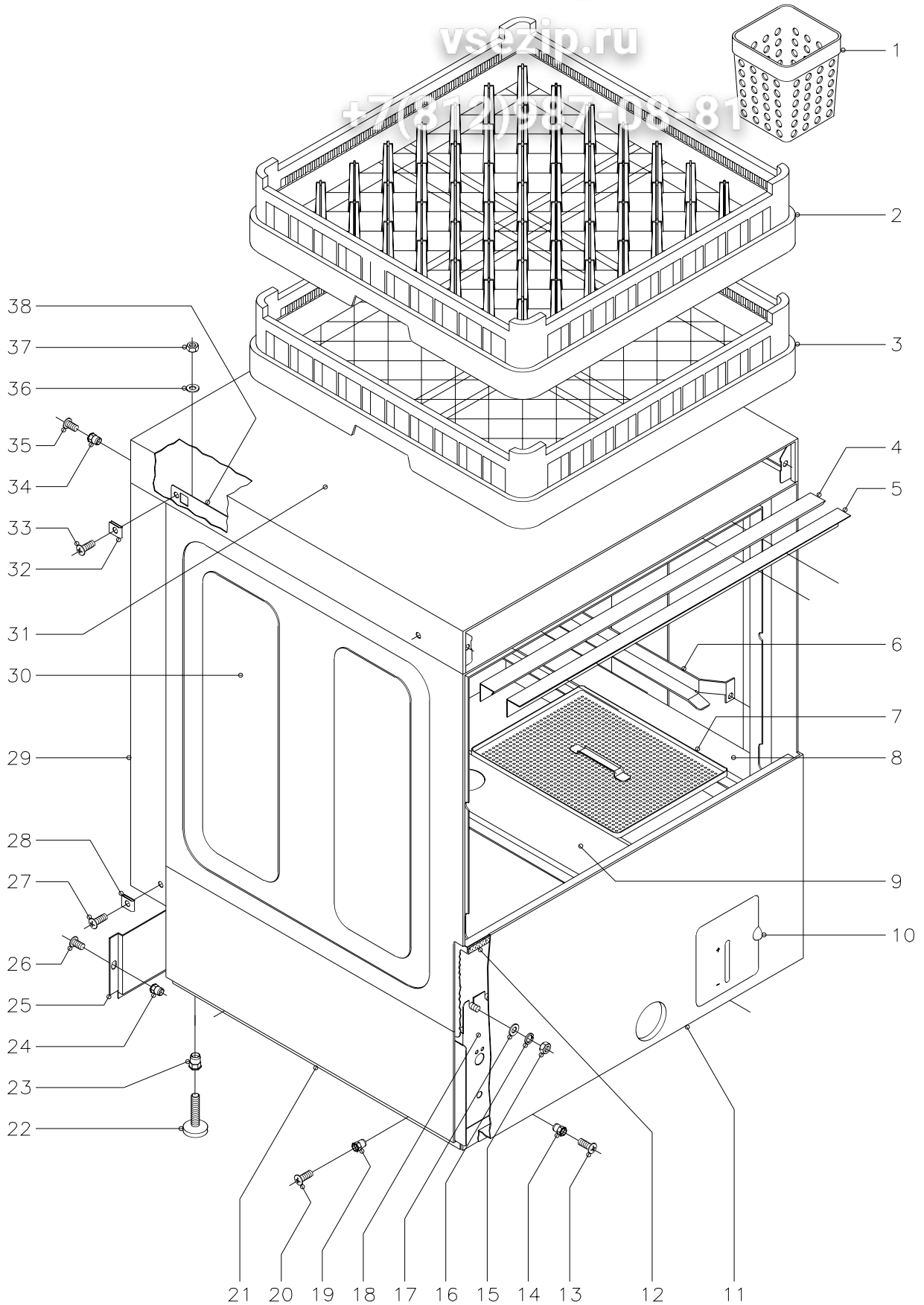

N plano
C-935

Firma

Fecha
12-00

Aparato
LAVAVAJILLAS 48;48B;64;64B

Lamina
1

Fagor Industrial S.Coop.
O<ate



Зип Общепит

vsezip.ru

ZONA

+7(812)987-08-81

MOD.		LAVAVAJILLAS FRONTAL	ZONA	MUEBLE Y CESTILOS			
ITEM	CODIGO	DENOMINACION	TEXTO	FI-48	FI-48B	FI-64	FI-64B
1	Z655314	Cestillo cubiertos		4	4	4	4
2	Z655302	Cestillo platos CP-16/18		1	1	1	1
3	Z655301	Cestillo base CT-10		1	1	1	1
4	Z200315	Perfil caja		1	1	1	1
5	Z200309	Escuadra sujecion perfil		1	1	1	1
6	Z200305	Guia cestillo derecha		1	1	1	1
s/n	Z200306	Guia cestillo izquierda		1	1	1	1
	Q232040	Arandela plana A-6		4	4	4	4
	Q162040	Tuerca exagonal M-6		4	4	4	4
7	Z210801	Bandeja filtro		4	4	4	4
8	Z210805	Soporte derecho bandejas		1	1	1	1
s/n	Z210806	Soporte izquierdo bandejas		1	1	1	1
9	Z210804	Soporte central bandejas		1	1	1	1
	Q232040	Arandela plana A-6		8	8	8	8
	Q162040	Tuerca exagonal M-6		8	8	8	8
10	Z212902	Puerta deposito completa		1	1	1	1
s/n	Z212906	Eje puerta		1	1	1	1
s/n	Q372001	Pasador de aletas Ø2x15		2	2	2	2
11	Z218611	Panel frontal		1	-	1	-
11	Z228811	Panel frontal		-	1	-	1
12	Z200313	Perfil goma esponjosa		1	1	1	1
13	Q152004	Tornillo aplastado M-5x13		2	2	2	2
14	Q221342	Remache exagonal M-5		2	2	2	2
15	Q162040	Tuerca exagonal M-6		8	8	8	8
16	Q262040	Arandela muelle A-6		8	8	8	8
17	Q232040	Arandela plana A-6		8	8	8	8
18	Z200101	Armazon completo		1	1	1	1
19	Q221342	Remache exagonal M-5		4	4	4	4
20	Q152004	Tornillo aplastado M-5x13		4	4	4	4

Зип Общепит

vsezip.ru

ZONA

MUEBLE Y CESTILOS

MOD.		LAVAVAJILLAS FRONTAL					
ITEM	CODIGO	DENOMINACION	TEXTO	FI-48	FI-48B	FI-64	FI-64B
21	Z202903	Panel lateral izquierdo		1	1	1	1
s/n	Z202902	Panel lateral derecho		1	1	1	1
22	Z200105	Pata regulable		4	4	4	4
23	Q221345	Remache exagonal M-10		4	4	4	4
24	Q221342	Remache exagonal M-5		2	2	2	2
25	Z202905	Panel posterior inferior		1	1	1	1
26	Q152004	Tornillo aplastado M-5x13		2	2	2	2
27	Q152004	Tornillo aplastado M-5x13		2	2	2	2
28	Q221012	Tuerca rapida M-5		2	2	2	2
29	Z212907	Panel posterior		1	1	1	1
30	Z200325	Caja soldada		1	1	1	1
31	Z202906	Tapa		1	1	1	1
32	Q221012	Tuerca rapida M-5		4	4	4	4
33	Q152004	Tornillo aplastado M-5x13		4	4	4	4
34	Q221342	Remache exagonal M-5		2	2	2	2
35	Q152004	Tornillo aplastado M-5x13		2	2	2	2
36	Q232040	Arandela plana A-6		4	4	4	4
37	Q162040	Tuerca exagonal M-6		4	4	4	4
38	Z200307	Escuadra amarre tapa		2	2	2	2

Зип Общепит

vsezip.ru

+7(812)987-08-81

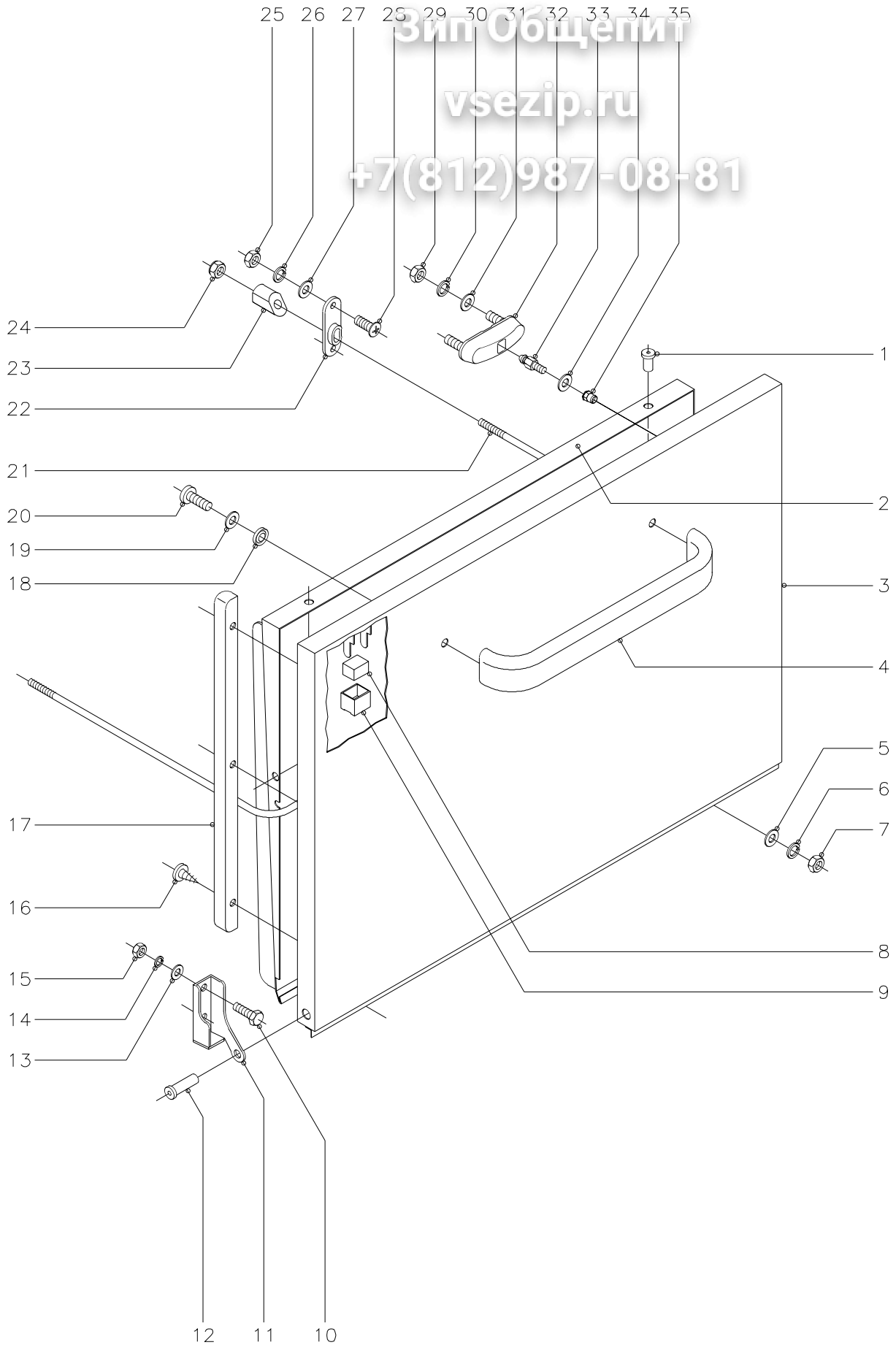

N plano
C-936

Firma

Fecha
12-00

Aparato
LAVAVAJILLAS 48;48B;64;64B

Lamina
2

Fagor Industrial S.Coop.
O<ate



Зип Общепит

vsezip.ru

ZONA

MOD.		LAVAVAJILLAS FRONTAL	PUERTA				
ITEM	CODIGO	DENOMINACION	TEXTO	FI-48	FI-48B	FI-64	FI-64B
1	Q412000	Remache tubular Ø4x8		4	4	4	4
2	Z200545	Contrapuerta soldada		1	1	1	1
3	Z200541	Puerta soldada		1	1	1	1
4	Z200512	Asa puerta		1	1	1	1
5	Q232030	Arandela plana A-5		2	2	2	2
6	Q262030	Arandela muelle A-5		2	2	2	2
7	Q162030	Tuerca exagonal M-5		2	2	2	2
8	Z200506	Iman		1	1	1	1
9	Z200507	Protector iman		1	1	1	1
10	Q012042	Tornillo exagonal M-6x15		4	4	4	4
11	Z400514	Bisagra izquierda		1	1	1	1
s/n	Z400515	Bisagra derecha		1	1	1	1
12	Z400516	Eje puerta		2	2	2	2
13	Q232040	Arandela plana A-6		4	4	4	4
14	Q262040	Arandela muelle A-6		4	4	4	4
15	Q162040	Tuerca exagonal M-6		4	4	4	4
16	Q082005	Tornillo chapa 4,2x13		6	6	6	6
17	Z200524	Marco puerta		2	2	2	2
18	Q308002	Arandela dubo A-6		2	2	2	2
19	Q232040	Arandela plana A-6		2	2	2	2
20	Q032041	Tornillo alomado M-6x10		2	2	2	2
21	Z200521	Varilla tensor		1	1	1	1
22	Z200310	Soporte tensor		2	2	2	2
23	Z200522	Tensor de puerta		2	2	2	2
24	Q222012	Tuerca autoblocante M-6		2	2	2	2
25	Q162030	Tuerca exagonal M-5		4	4	4	4
26	Q262030	Arandela muelle A-5		4	4	4	4
27	Q232030	Arandela plana A-5		4	4	4	4
28	Q152004	Tornillo aplastado M-5x13		4	4	4	4

Зип Общепит

vsezip.ru

+7(812)987-08-81

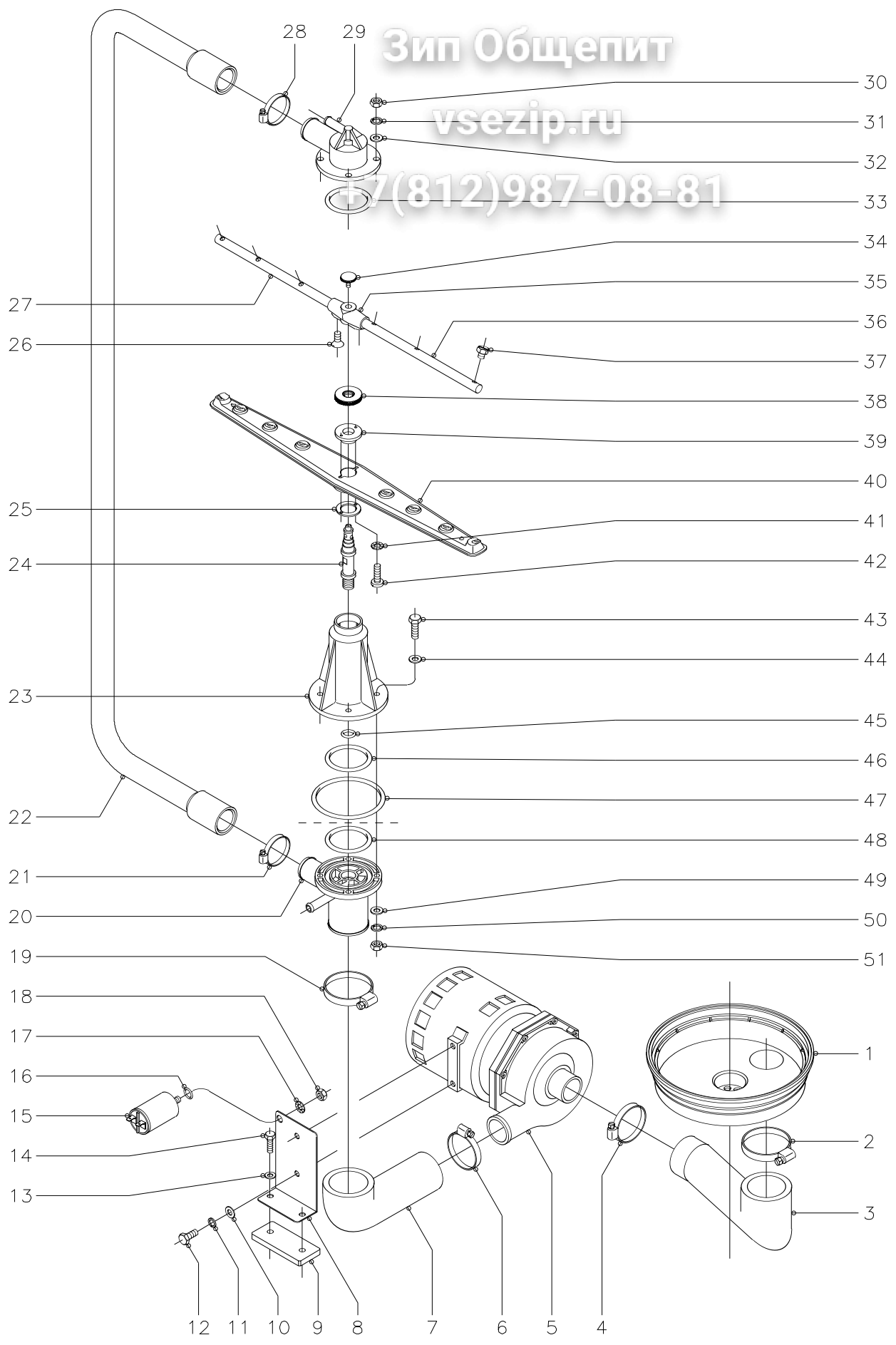

N plano C-937	Firma 	Fecha 12-00	Aparato LAVAVAJILLAS 48;48B;64;64B	Lamina 3	Fagor Industrial S.Coop. FAGOR
------------------	-----------	----------------	---------------------------------------	-------------	---------------------------------------

MOD.		LAVAVAJILLAS FRONTAL	ZONA	PARTE FUNCIONAL DE LAVADO			
ITEM	CODIGO	DENOMINACION	TEXTO	FI-48	FI-48B	FI-64	FI-64B
1	Z200906	Cubeta		1	1	1	1
2	Q881324	Abrazadera 50 - 70		1	1	1	1
3	Z200904	Codo aspiracion		1	1	1	1
4	Q881307	Abrazadera 40 - 60		1	1	1	1
5	Z201011	Bomba de lavado (230 V., 50 Hz.)		1	1	1	1
5	Z203511	Bomba de lavado (230 V., 60 Hz.)		1	1	1	1
	Z201081	Conjunto junta y reten		1	1	1	1
	Z201082	Turbina 50 Hz. (Ø 88 mm.)		1	1	1	1
	Z203571	Turbina 60 Hz. (Ø 77 mm.)		1	1	1	1
6	Q881307	Abrazadera 40 - 60		1	1	1	1
7	Z200905	Codo impulsion		1	1	1	1
8	Z201002	Soporte motobomba		1	1	1	1
9	Z201003	Base bomba lavado		1	1	1	1
10	Q232040	Arandela plana A-6		2	2	2	2
11	Q262040	Arandela muelle A-6		2	2	2	2
12	Q012041	Tornillo exagonal M-6x10		2	2	2	2
13	Q232030	Arandela plana A-5		2	2	2	2
14	Q012033	Tornillo exagonal M-5x20		2	2	2	2
15	V321300	Condensador 10 mF.		1	1	1	1
16	Q307048	Junta torica Ø16,18xØ9,12xØ3,53		1	1	1	1
17	Q242050	Arandela abanico A-8		1	1	1	1
18	Q162050	Tuerca exagonal M-8		1	1	1	1
19	Q881324	Abrazadera 50 - 70		1	1	1	1
20	Z200703	Pasamuros		1	1	1	1
21	Q881305	Abrazadera 25 - 40		1	1	1	1
22	Z200706	Arbol de lavado		1	1	1	1
23	Z200701	Soporte distribuidor inferior		1	1	1	1
24	Z200704	Eje central		2	2	2	2
25	Z650711	Amarre enganche distribuidor		2	2	2	2

MOD.	LAVAVAJILLAS FRONTAL		ZONA	PARTE FUNCIONAL DE LAVADO			
ITEM	CODIGO	DENOMINACION	TEXTO	FI-48	FI-48B	FI-64	FI-64B
26	Q152024	Tornillo avellanado M-4x8		4	4	4	4
27	Z201902	Rama aclarado izquierda		2	2	2	2
28	Q881305	Abrazadera 25 - 40		1	1	1	1
29	Z200707	Soporte distribuidor superior		1	1	1	1
30	Q162040	Tuerca exagonal M-6		4	4	4	4
31	Q262040	Arandela muelle A-6		4	4	4	4
32	Q232040	Arandela plana A-6		4	4	4	4
33	Q307052	Junta torica Ø60,83xØ50,17xØ5,33		1	1	1	1
34	Q152016	Tornillo especial M-5x0,8		2	2	2	2
35	Z201903	Soporte ramas aclarado		2	2	2	2
36	Z201901	Rama aclarado derecha		2	2	2	2
37	Z211903	Tobera aclarado		12	12	12	12
38	Z200705	Tuerca especial M-14x1		2	2	2	2
39	Z650704	Enganche distribuidor		2	2	2	2
40	Z650716	Distribuidor montado		2	2	2	2
41	Q242010	Arandela abanico A-3		4	4	4	4
42	Q152015	Tornillo alomado M-3x6		4	4	4	4
43	Q012046	Tornillo exagonal M-6x40		4	4	4	4
44	Q306050	Arandela fibra roja Ø11xØ6,2x1,5		4	4	4	4
45	Q307050	Junta torica Ø19,18xØ13,94xØ2,62		1	1	1	1
46	Q307052	Junta torica Ø60,83xØ50,17xØ5,33		1	1	1	1
47	Q307049	Junta torica Ø95,75xØ85,09xØ5,33		1	1	1	1
48	Q307052	Junta torica Ø60,83xØ50,17xØ5,33		1	1	1	1
49	Q232040	Arandela plana A-6		4	4	4	4
50	Q262040	Arandela muelle A-6		4	4	4	4
51	Q162040	Tuerca exagonal M-6		4	4	4	4

Зип Общепит

vsezip.ru

+7(812)987-08-81

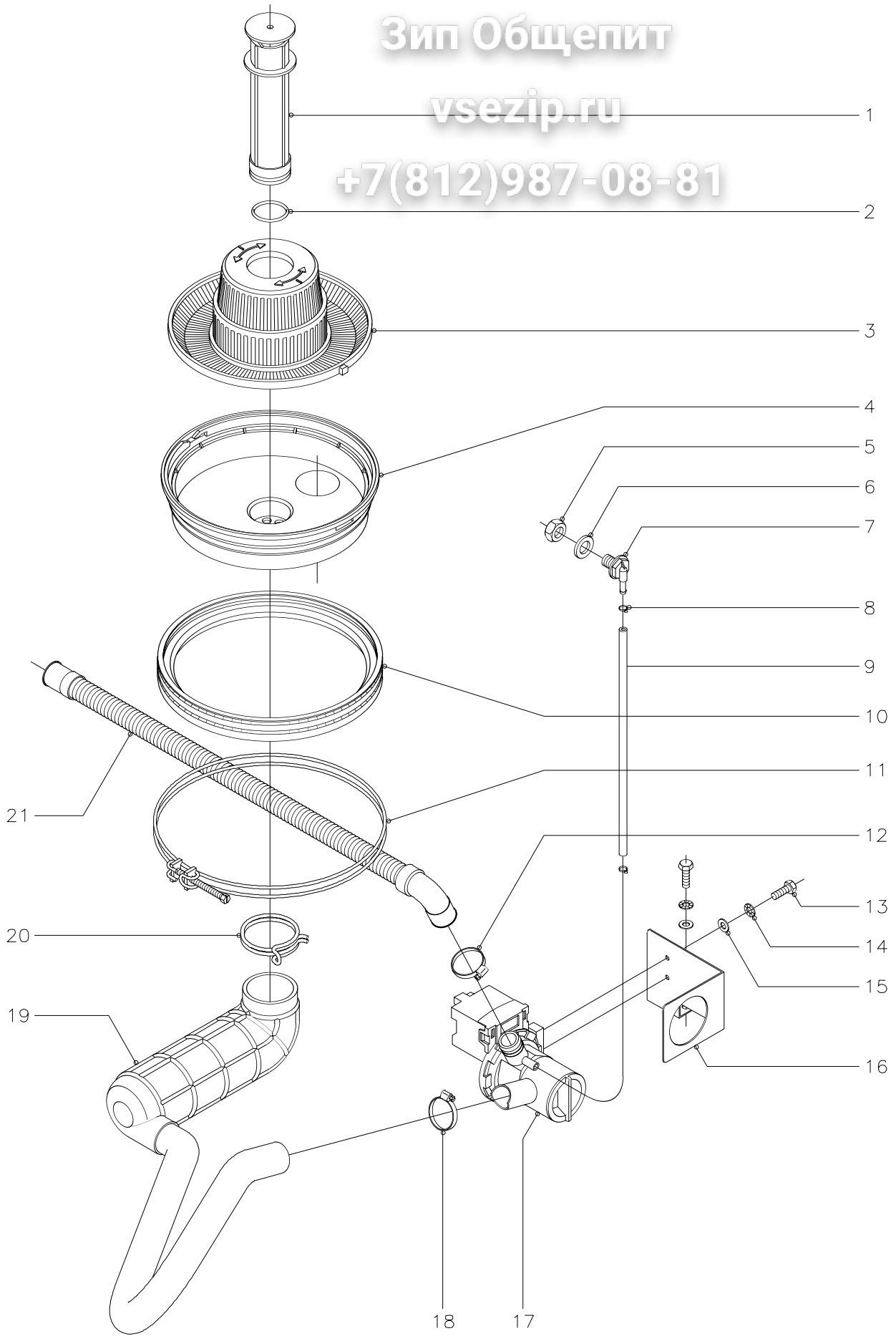

N plano C-938	Firma 	Fecha 12-00	Aparato LAVAVAJILLAS FI-48B;FI-64B	Lamina 4	Fagor Industrial S.Coop. FAGOR
------------------	-----------	----------------	---------------------------------------	-------------	---------------------------------------

Зип Общепит

vsezip.ru

+7(812)987-08-81

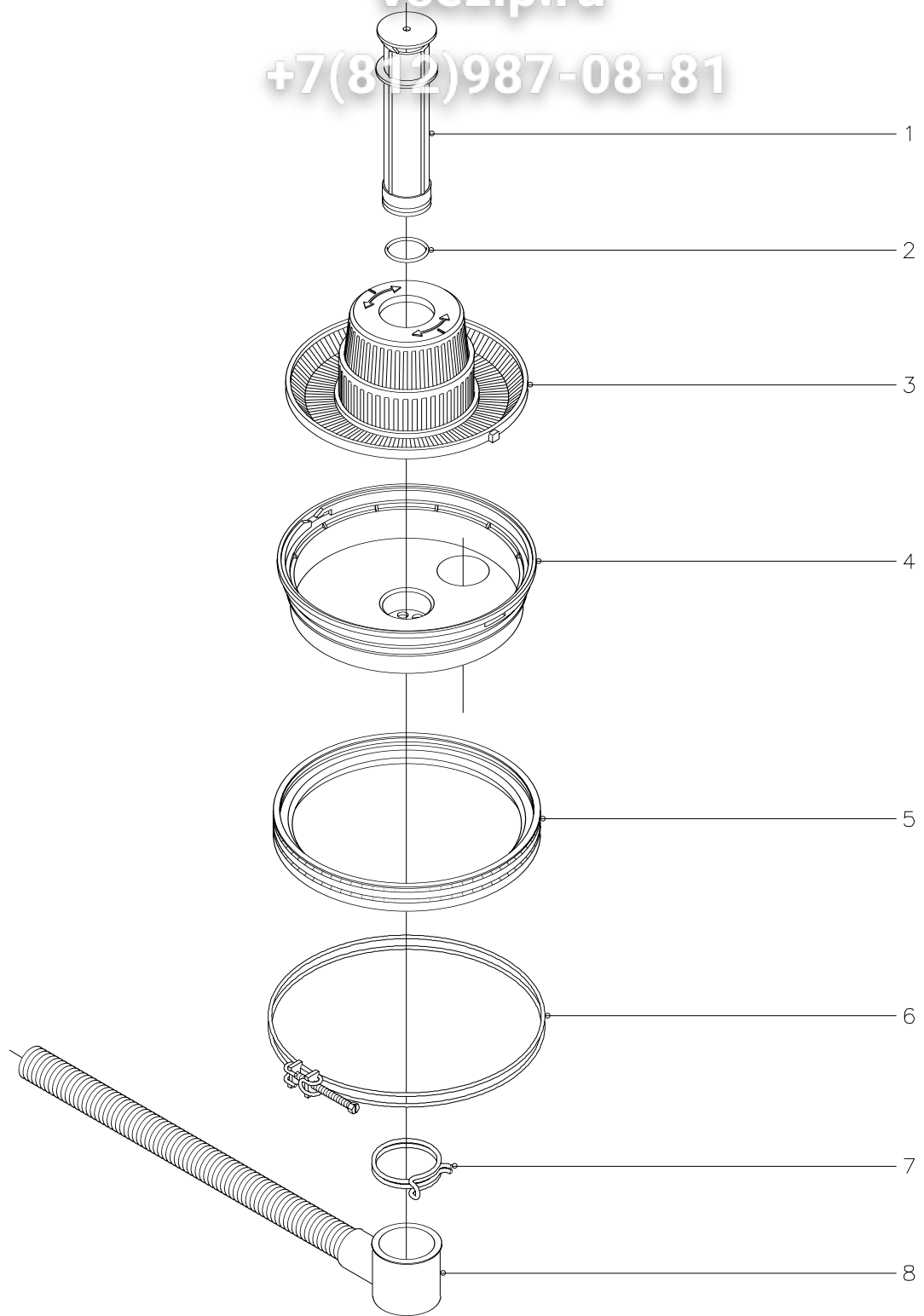

N plano

C-939

Firma

Fecha

12-00

Aparato

LAVAVAJILLAS FI-48;FI-64

Lamina

5

Fagor Industrial S.Coop.
Olate

FAGOR

Зип Общепит

vsezip.ru

+7(812)987-08-81

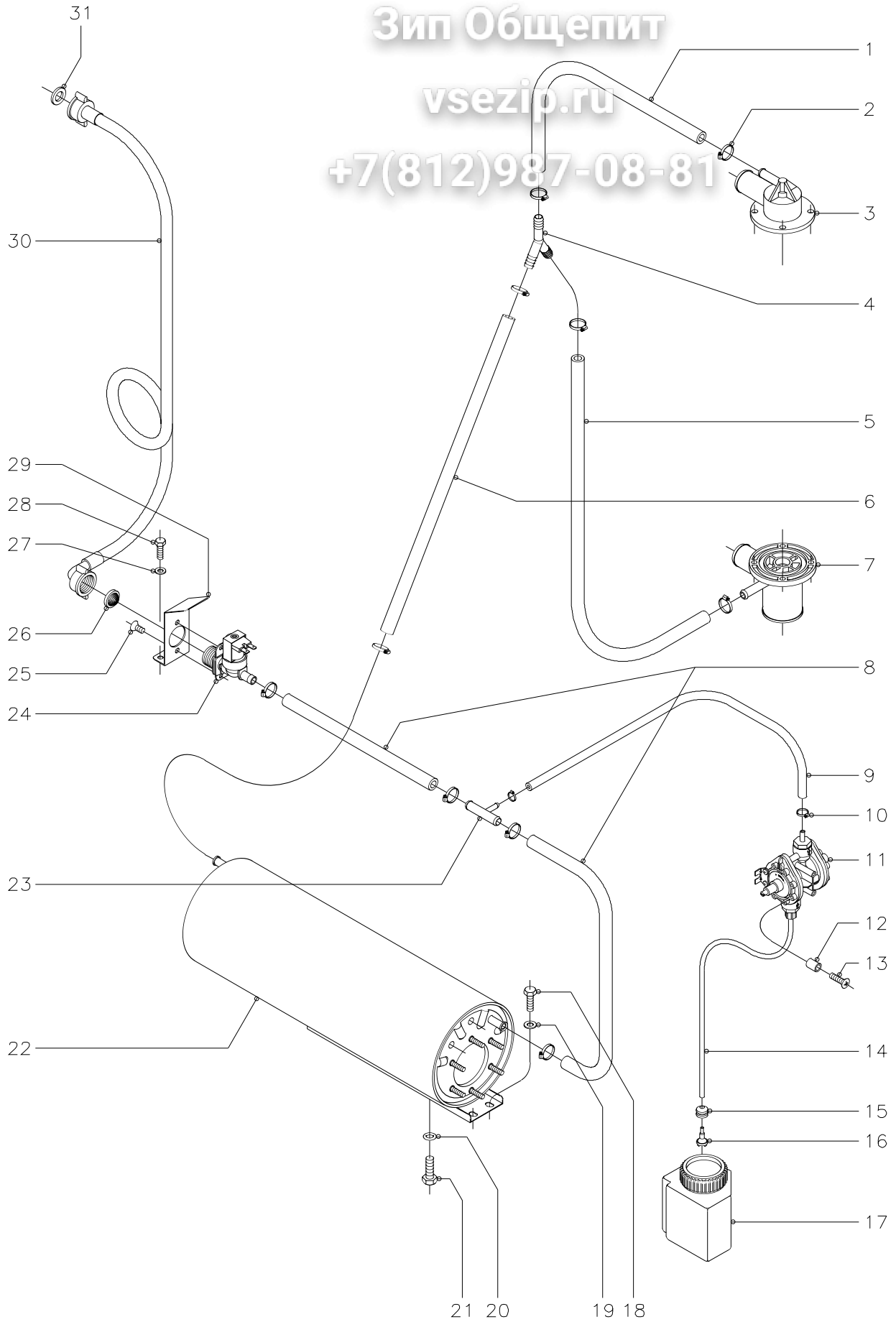

N plano
C-940

Firma
[Signature]

Fecha
12-00

Aparato
LAVAVAJILLAS 48;48B;64;64B

Lamina
6

Fagor Industrial S.Coop.
Ocate



Зип Ощепит

vsezip.ru

ZONA

PARTE FUNCIONAL ACLARADO

+7(812)987-08-81

MOD.	LAVAVAJILLAS FRONTAL			PARTE FUNCIONAL ACLARADO			
ITEM	CODIGO	DENOMINACION	TEXTO	FI-48	FI-48B	FI-64	FI-64B
1	3676900	Tubo goma negra Ø17xØ10x360		1	1	1	1
2	Q881302	Abrazadera 12 - 20		10	10	10	10
3	Z200707	Soporte distribuidor superior		1	1	1	1
4	Z201106	Racord en "Y"		1	1	1	1
5	3676900	Tubo goma negra Ø17xØ10x780		1	1	1	1
6	3676900	Tubo goma negra Ø17xØ10x580		1	1	1	1
7	Z200703	Pasamuros		1	1	1	1
8	3676900	Tubo goma negra Ø17xØ10x330		2	2	2	2
9	3704000	Tubo goma negra Ø10,5xØ5x620		1	1	1	1
10	Q881308	Abrazadera 8 - 14		2	2	2	2
11	Z651123	Dosificador tensoactivo		1	1	1	1
12	Z203007	Casquillo		2	2	2	2
13	Q041324	Tornillo avellanado M-4x25		2	2	2	2
14	3699200	Conducto tensoactivo Ø6xØ4x650		1	1	1	1
15	N023064	Pasamuros Ø6xØ13		1	1	1	1
16	Z601153	Filtro aspiracion tensoactivo		1	1	1	1
17	Z211101	Deposito abrillantador tensoactivo		1	1	1	1
18	Q012031	Tornillo exagonal M-5x10		2	2	2	2
19	Q232030	Arandela plana A-5		2	2	2	2
20	Q307048	Junta torica Ø16,18xØ9,12xØ3,53		1	1	1	1
21	Q012063	Tornillo exagonal M-10x20		1	1	1	1
22	Z201710	Cuerpo calderin		1	1	1	1
23	Z601157	Toma presion		1	1	1	1
24	Z701135	Electrovalvula entrada de agua		1	1	1	1
25	Q152024	Tornillo avellanado M-4x8		2	2	2	2
26	Z701132	Filtro junta		1	1	1	1
27	Q232030	Arandela plana A-5		2	2	2	2
28	Q012031	Tornillo exagonal M-5x10		2	2	2	2
29	Z201101	Escuadra amarre electrovalvula		1	1	1	1

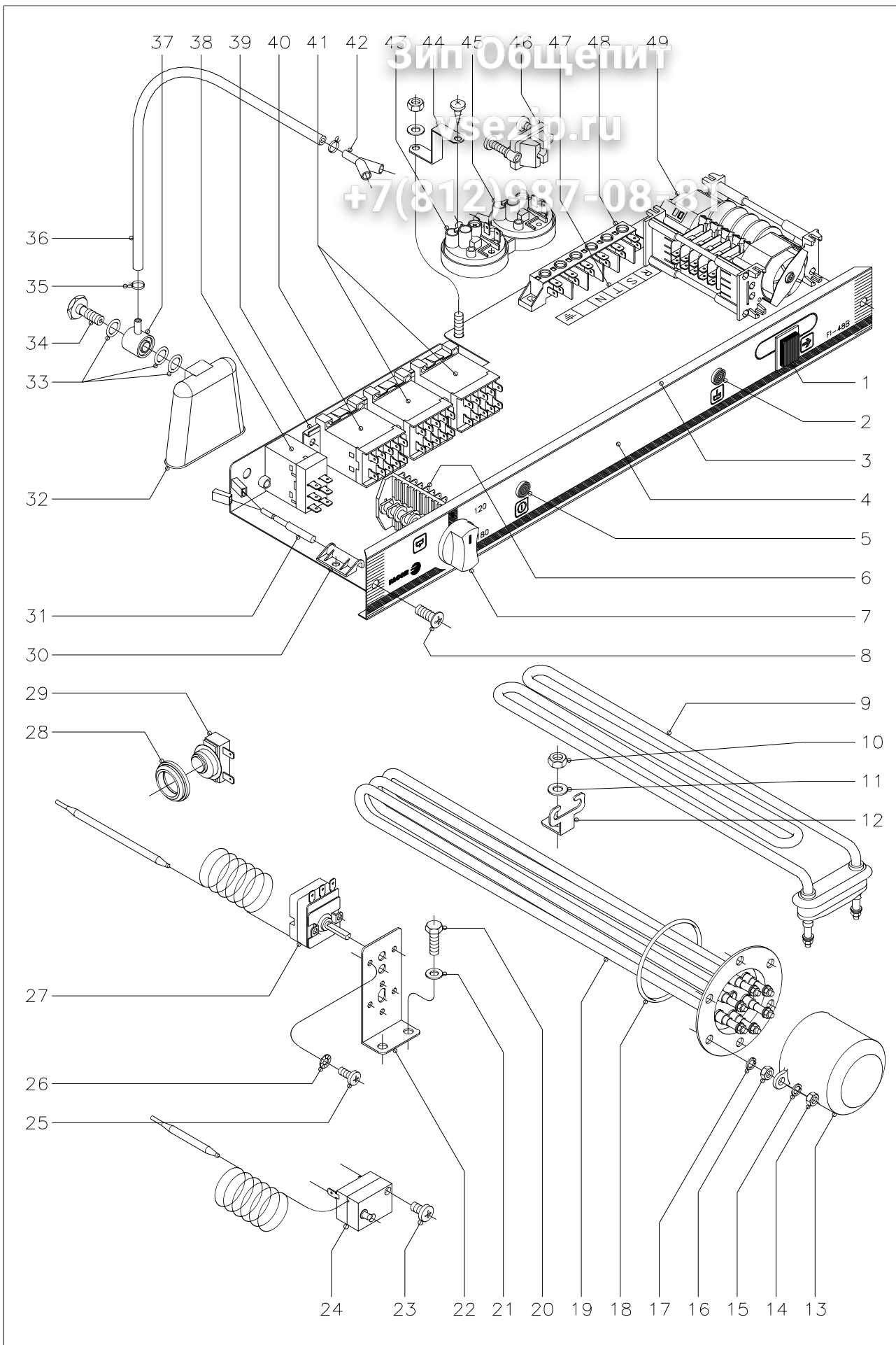

ЗипОбщепит
 usezip.ru
 +7(812)987-08-81

N plano C-941	Firma <i>Dinamo</i>	Fecha 12-00	Aparato LAVAVAJILLAS 48;48B;64;64B	Lamina 7	Fagor Industrial S.Coop. D<cate	FAGOR
------------------	------------------------	----------------	---------------------------------------	-------------	------------------------------------	--------------

Зип Общепит

vsezip.ru

+7(812)987-08-81

MOD.		LAVAVAJILLAS FRONTAL		ZONA	PARTE FUNCIONAL ELECTRICA			
ITEM	CODIGO	DENOMINACION	TEXTO	FI-48	FI-48B	FI-64	FI-64B	
1	Z213033	Pulsador de marcha		1	1	1	1	
2	Z203004	Piloto verde		1	1	1	1	
3	Z212909	Frente extraible		1	1	1	1	
4	Z212910	Embellecedor adhesivo		1	-	-	-	
4	Z222902	Embellecedor adhesivo		-	1	-	-	
4	Z242901	Embellecedor adhesivo		-	-	1	-	
4	Z252901	Embellecedor adhesivo		-	-	-	1	
5	Z203005	Piloto ambar		1	1	1	1	
6	Z213003	Conmutador de funciones		1	-	1	-	
6	Z223001	Conmutador de funciones		-	1	-	1	
7	R663062	Boton de mando completo		1	1	1	1	
8	Q152004	Tornillo aplastado M-5x13		2	2	2	2	
9	Z203601	Resistencia tanque 2800 W.230V.		1	1	1	1	
10	Q162040	Tuerca exagonal M-6		1	1	1	1	
11	Q232040	Arandela plana A-6		1	1	1	1	
12	Z603602	Soporte resistencia tanque		1	1	1	1	
13	Z651731	Caperuza resistencia calderin		1	1	1	1	
14	Q163140	Tuerca exagonal M-6		2	2	2	2	
15	Q262040	Arandela muelle A-6		2	2	2	2	
16	Q163140	Tuerca exagonal M-6		6	6	6	6	
17	Q262040	Arandela muelle A-6		6	6	6	6	
18	Q307035	Junta torica AN-36		1	1	1	1	
19	Z201706	Resistencia calderin 2800 W.230V.		1	1	-	-	
19	Z241701	Resistencia calderin 6000 W.230V.		-	-	1	1	
20	Q012031	Tornillo exagonal M-5x10		2	2	2	2	
21	Q232030	Arandela plana A-5		2	2	2	2	
22	Z203016	Soporte termostatos		1	1	1	1	
23	Q081330	Tornillo alomado BZ-3,5X6,5		2	2	2	2	
24	Z213014	Termostato limitador		1	1	1	1	

Зип Общепит

vsezip.ru

ZONA

PARTE FUNCIONAL ELECTRICA

+7(812)987-08-81

MOD.		LAVAVAJILLAS FRONTAL					
ITEM	CODIGO	DENOMINACION	TEXTO	FI-48	FI-48B	FI-64	FI-64B
25	Q152024	Tornillo avellanado M-4x8		2	2	2	2
26	Q242020	Arandela abanico A-4		2	2	2	2
27	Z203014	Termostato calderin		1	1	1	1
28	N503017	Soporte termostato		1	1	1	1
29	Z718405	Termostato doble (tanque)		1	1	1	1
30	Z203010	Amarre interruptor magnetico		1	1	1	1
31	Z203009	Interruptor magnetico		1	1	1	1
32	Z203011	Camara presostato		1	1	1	1
33	Q307003	Junta torica Ø16,01xØ10,77xØ2,62		3	3	3	3
34	Z203013	Tornillo presostato		1	1	1	1
35	P102154	Brida elastica para tubo		2	2	2	2
36	3702400	Tubo goma negra Ø8xØ4x1300		1	1	1	1
37	Z203012	Empalme presostato		1	1	1	1
38	Z203018	Rele puerta 230 V., 50/60 Hz.		1	1	1	1
39	Z123018	Guia contactor L=55		2	2	-	-
39	Z103084	Guia contactor L=138		-	-	1	1
40	Z213007	Contactador 230 V. 50/60 Hz.(tanque)		1	1	1	1
41	Z213007	Contactador 230V.50/60 Hz.(calderin)		-	-	2	2
41	Z203050	Contactador 230V.50/60 Hz.(calderin)		1	1	-	-
42	Z103077	Racord en "Y"		-	1	-	1
43	Z203023	Presostato de nivel		1	1	1	1
	Q082032	Tornillo alomado BZ-3,5x9,5		1	1	1	1
44	Z602923	Soporte presostato		1	1	1	1
	Q152004	Tornillo aplastado M-5x13		1	1	1	1
	Q232030	Arandela plana A-5		1	1	1	1
	Q162030	Tuerca exagonal M-5		1	1	1	1
45	Z223005	Presostato de seguridad		-	1	-	1
46	Z203020	Retenedor de cable		1	1	1	1
47	Z213005	Rotulo adhesivo RSTN		1	1	1	1

Зип Общепит

vsezip.ru

+7(812)987-08991

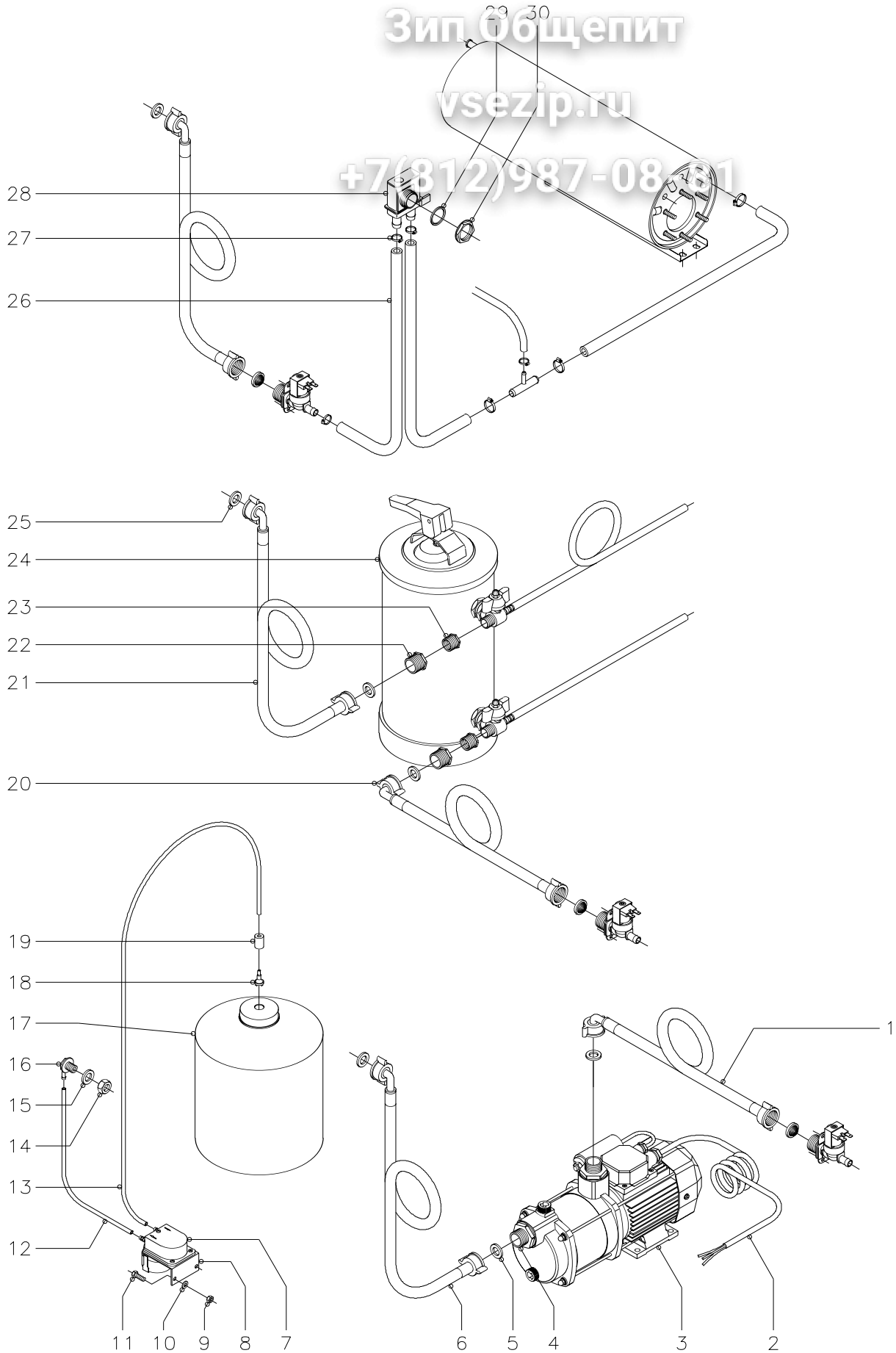

N plano
C-942

Firma

Fecha
12-00

Aparato
ACCESORIOS LAVAVAJILLAS

Lamina
7

Fagor Industrial S.Coop.
Olate



Зип Общепит

vsezip.ru

Zeichnung fehlt zu Stückliste

+7(812)987-08-81

Without drawing fort the components list

Pas de d



Manca il disegno per l'elenco di pezzi

Рисунок отсутствует для каталога запасных частей

Falta el diseño para la lis

Зип Общепит

vsezip.ru

+7(812)987-08-81

MOD.		LAVAVAJILLAS FRONTAL		ZONA	PIEZAS ESPECIFICAS (FI-48W, FI-64W (208 - 240 V. , II , 60 Hz.)						
ITEM	CODIGO	DENOMINACION	TEXTO	FI-48-W	FI-48B	FI-64-W	FI-64B				
	Z228401	Embellecedor adhesivo W (48)		1	-						
	Z258401	Embellecedor adhesivo W (64)		-	1						
	Z228412	Programador ciclo 60 Hz. T. Stop		1	-						
	Z258412	Programador ciclo 60 Hz. T. Stop		-	1						
	Z683087	Contactador 3TF20 01-3AL2, 230 V.		1	1						
	Z408408	Cable alimentacion USA		1	-						
	Z229011	Cableado termo-stop		1	-						
	Z229009	Cableado termo-stop		-	1						
	Z228407	Esquema elect. montaje W		1	-						
	Z258406	Esquema elect. montaje W		-	1						
	Z228402	Esquema electrico adhesivo		1	-						
	Z258402	Esquema electrico adhesivo		-	1						
	Z231105	Valvula antirretorno		1	1						
	Q307029	Arandela junta Ø31xØ26,5x2		1	1						
	R023025	Contratuerca		1	1						
	Z228405	Indicador analogico Fahrenheit		2	2						
	Z263002	Vaina para sonda (tanque)		1	1						
	Q306024	Arandela junta Ø18xØ12,5x1,5		1	1						
	Q162070	Tuerca exagonal M-12		1	1						
	Z203511	Bomba de lavado 60 Hz.		1	1						
	Z223501	Bomba de desagüe 60 Hz.		1	1						
	Z218424	Puerta deposito completa		1	1						
	Q013023	Tornillo exagonal M-4x20		2	2						
	Z208432	Folleto de instrucciones		1	1						
	R696507	Etiqueta de precaucion		1	1						
	R726512	Etiqueta advertencia legal		1	1						
	Z228435	Etiqueta conexiones		1	-						
	Z258435	Etiqueta conexiones		-	1						
	Z718434	Etiqueta seguridad electrica		1	1						

Зип Общепит

vsezip.ru

+7(812)987-08-81

MOD.		LAVAVAJILLAS FRONTAL		ZONA	PIEZAS ESPECIFICAS (MF-48, MF-64 (208 - 240 V. , II , 60 Hz.)						
ITEM	CODIGO	DENOMINACION	TEXTO	MF-48	FI-48B	MF-64	FI-64B				
	Z228501	Embellecedor adhesivo MF		1	-						
	Z258501	Embellecedor adhesivo MF		-	1						
	Z228412	Programador ciclo 60 Hz. T. Stop		1	-						
	Z258412	Programador ciclo 60 Hz. T. Stop		-	1						
	Z683087	Contactador 3TF20 01-3AL2, 230 V.		1	1						
	Z408408	Cable alimentacion USA		1	-						
	Z229011	Cableado termo-stop		1	-						
	Z229009	Cableado termo-stop		-	1						
	Z228407	Esquema elect. montaje		1	-						
	Z258406	Esquema elect. montaje		-	1						
	Z228402	Esquema electrico adhesivo		1	-						
	Z258402	Esquema electrico adhesivo		-	1						
	Z231105	Valvula antirretorno		1	1						
	Q307029	Arandela junta Ø31xØ26,5x2		1	1						
	R023025	Contratuerca		1	1						
	Z228405	Indicador analogico Fahrenheit		2	2						
	Z263002	Vaina para sonda (tanque)		1	1						
	Q306024	Arandela junta Ø18xØ12,5x1,5		1	1						
	Q162070	Tuerca exagonal M-12		1	1						
	Z203511	Bomba de lavado 60 Hz.		1	1						
	Z223501	Bomba de desagüe 60 Hz.		1	1						
	Z218424	Puerta deposito completa		1	1						
	Q013023	Tornillo exagonal M-4x20		2	2						
	Z208432	Folleto de instrucciones		1	1						
	R696507	Etiqueta de precaucion		1	1						
	R726512	Etiqueta advertencia legal		1	1						
	Z228435	Etiqueta conexiones		1	-						
	Z258435	Etiqueta conexiones		-	1						
	Z718434	Etiqueta seguridad electrica		1	1						

Зип Общепит

vsezip.ru

+7(812)987-08-81

1N + 240V.

3N + 380 - 415 V.

Mod.: FI-48; A480; KM-48; FI-48 T ①

W4-A ②

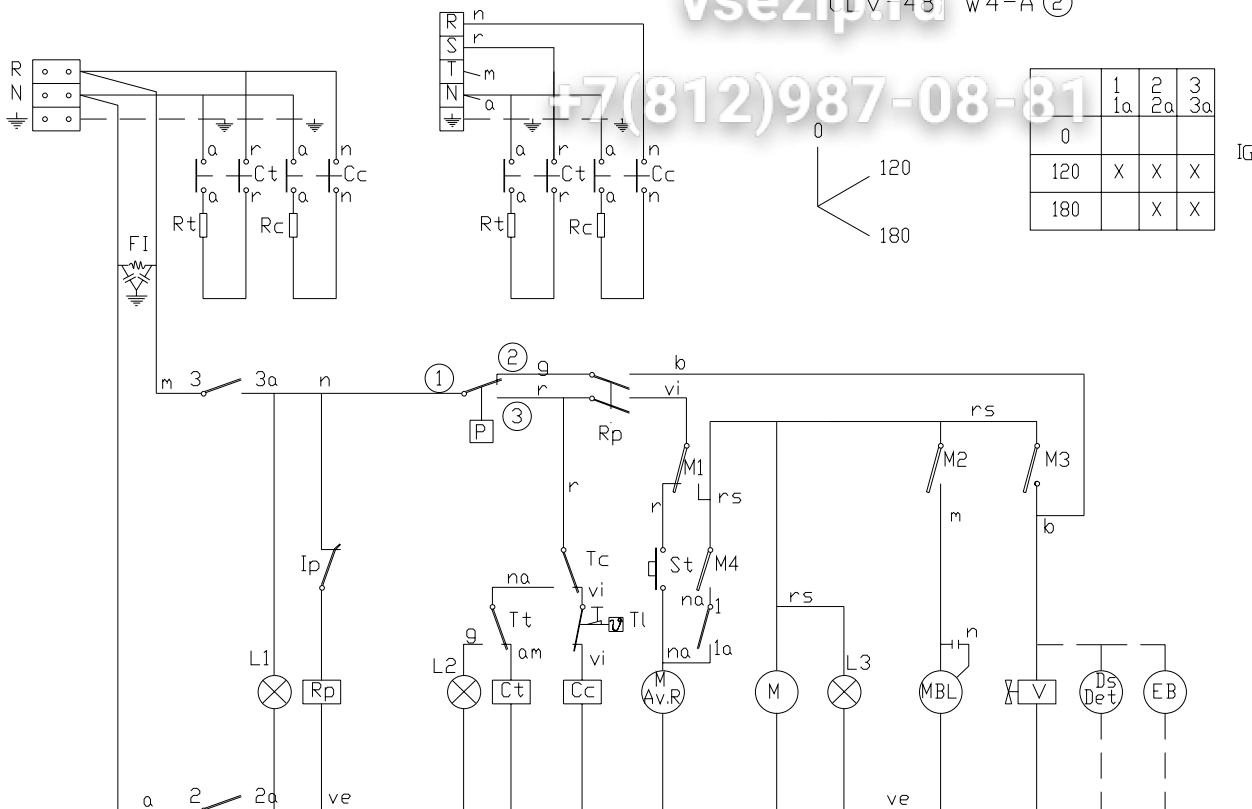

	1	2	3
0	1a	2a	3a
120	X	X	X
180		X	X

CODIGO DE COLORES:
 r = rojo-red-rouge
 m = marron-brown-m
 g = gris-grey-gris
 n = negro-black-noir
 a = azul-blue-bleu
 b = blanco-white-blanc
 vi = violeta-violette
 am = amarillo-yellow-jaune
 na = naranja-orange
 rs = rosa-rose-pink
 ve = verde-green-vert
 am/ve = amarillo verde

IG = Interruptor General
 L1 = Lampara de marcha
 Ip = Micro de puerta
 Rp = Relé puerta
 P = Presostato
 Tc = Termostato calderin
 Tt = Termostato tanque
 Tl = Termostato limitador de calderin
 Cc = Contactor calderin
 Ct = Contactor tanque
 L2 = Lampara máquina preparada
 Rc = Resistencia calderin
 St = Pulsador de marcha
 FI = Filtro de interferencias

Rt = Resistencia tanque
 M.Av.R = Motor programador Avance Rápido
 M = Motor programador
 M1 = Micro programador marcha
 M2 = Micro programador lavado
 M3 = Micro programador aclarado
 M4 = Micro programador Avance 120°
 L3 = Lámpara de ciclo
 MBL = Motobomba lavado
 C = Condensador de motobomba
 V = Válvula de llenado y aclarado
 Ds Det = Dosificador de detergente (opcional)
 EB = Electrobomba de presión (opcional)

Esquema teórico adhesivo		Papel adhesivo
N°	Pieza	Cant. Material
N°	Modificación	Propuesta de
①	Introducir denominación FI-48 T	Palacio
②	Introducir modelos CORECO Y W4-A	Palacio
Firma		Fecha
S. N.		27-9-95
Proyectado		FAGOR
Comprobado		Fagor Industrial, Koop
Escala		LAVAVAJILLAS
Plano hau ez daiteke erabili ez berrizta gure baimeniz gabe		

Зип Общепит

vsezip.ru

+7(812)987-08-81

1N + 240V.

3N + 380 - 415 V.

Mod.: FI-48 B; A480 B; CLV-48-B⁽¹⁾

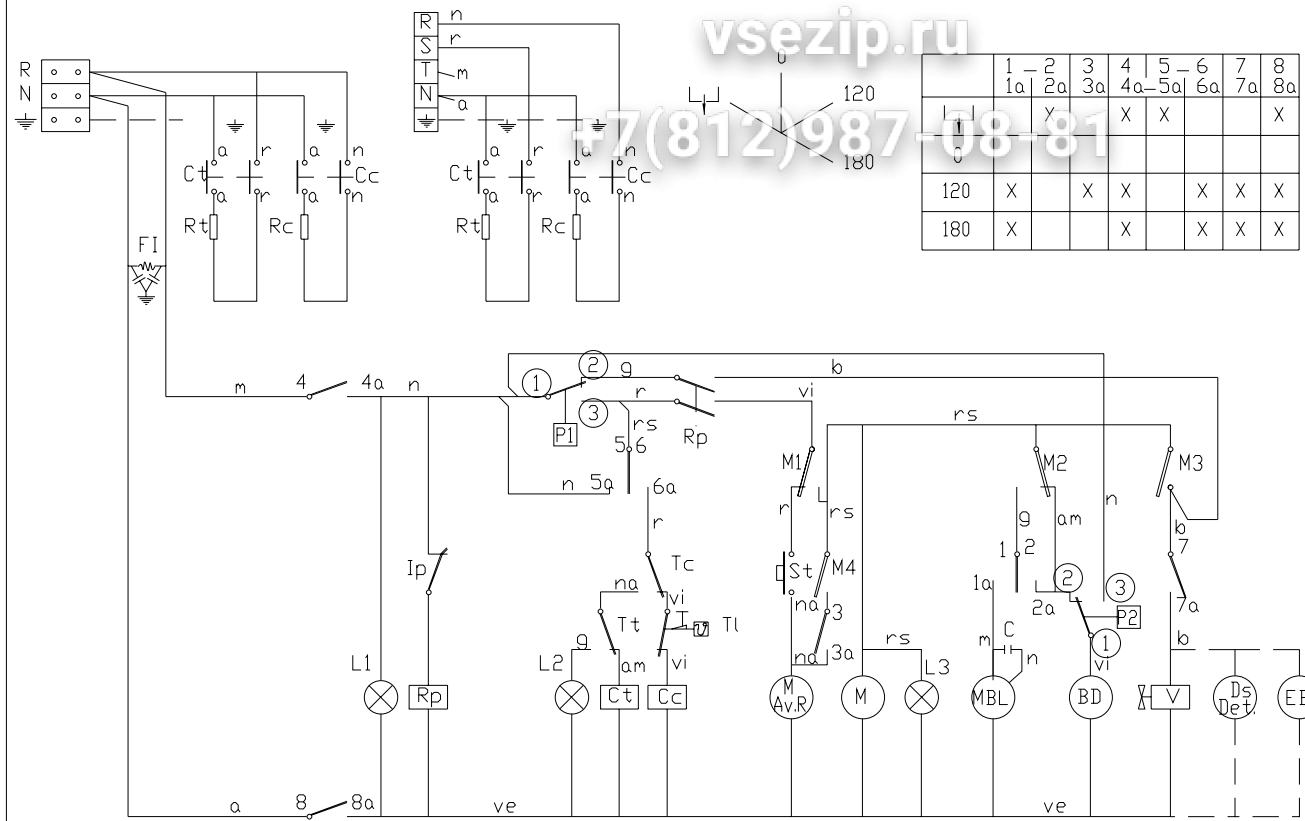

	1-2	3	4	5-6	7	8	
	1a	2a	3a	4a-5a	6a	7a	8a
120	X		X	X	X	X	X
180	X		X	X	X	X	X

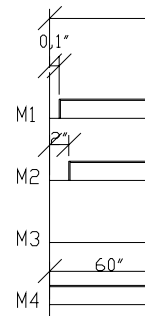

CODIGO DE COLORES
 r = rojo-red-red
 m = marron-brown
 g = gris-grey-grey
 n = negro-black
 a = azul-blue-blue
 b = blanco-white
 vi = violeta-violet
 am = amarillo-yellow
 na = naranja-orange
 rs = rosa-rose
 ve = verde-green
 am/ve = amarillo/verde

- Ig = Interruptor General
- L1 = Lampara de marcha
- Ip = Micro de puerta
- Rp = Relé puerta
- P1 = Presostato
- Tc = Termostato calderin
- Tt = Termostato tanque
- Tl = Termostato limitador de calderin
- Cc = Contactador calderin
- Ct = Contactador tanque
- L2 = Lampara máquina preparada
- Rc = Resistencia calderin
- St = Pulsador de marcha
- FI = Filtro de interferencias
- BD = Bomba de Desagüe

- Rt = Resistencia tanque
- M.Av.R = Motor programador Avance Rápido
- M = Motor programador
- M1 = Micro programador marcha
- M2 = Micro programador lavado
- M3 = Micro programador aclarado
- M4 = Micro programador Avance 120"
- L3 = Lámpara de ciclo
- MBL = Motobomba lavado
- C = Condensador de motobomba
- V = VALvula de llenado y aclarado
- Ds Det = Dosificador de detergente (opcional)
- P2 = Presostato de seguridad
- EB = Electrobomba de presión (opcional)

Esquema teorico adhesivo		Papel adhesivo
N°	Pieza	Cant. Material
N°	Modificacion	Propuesta de
①	Introducir modelo CORECO	Palacio
Firma		Fecha
Dibujado		S. N.
Proyectado		27-9-95
Comprobado		
Escala		
FAGOR		
Fagor Industrial, K...		
LAVAVAJILLAS		
Plano hau ez daiteke erabil ez berritza gure baimeniz gabe		

Зип Общепит

vsezip.ru

+7(812)987-08-81

3N ÷ 380/415V.

3 ÷ 220V.

1N ÷ 220 V./ 1N ÷ 240V.

Mod.: FI - 64

FI - 72

KM - 64

FI - 72 ①

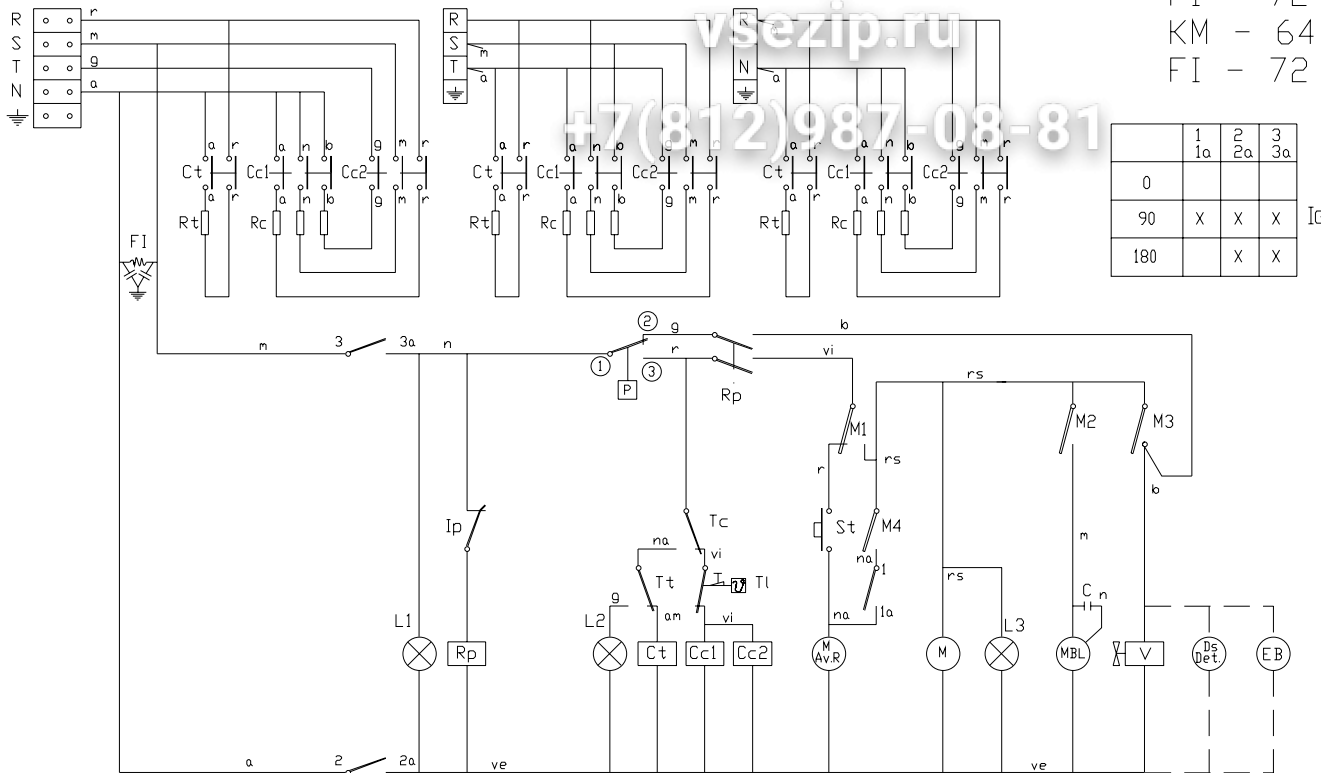

	1 1a	2 2a	3 3a	
0	X	X	X	I _G
90	X	X	X	
180	X	X	X	

CODIGO DE CO
 r = rojo-red
 m = marron-k
 g = gris-grey
 n = negro-bl
 a = azul-blue
 b = blanco-w
 vi = violeta-v
 am = amarillo
 rs = rosa-ro
 ve = verde-g
 am/ve = amar

NOTA
 - F
 - G
 - D
 - N

I_G = Interruptor General

L1 = Lampara de marcha

Ip = Micro de puerta

Rp = Relé puerta

P = Presostato

Tc = Termostato calderin

Tt = Termostato tanque

Tl = Termostato limitador de calderin

Cc1, Cc2 = Contactor calderin

Ct = Contactor tanque

L2 = Lampara máquina preparada

Rc = Resistencia calderin

St = Pulsador de marcha

FI = Filtro de interferencias

Rt = Resistencia tanque

M.A.V.R = Motor programador Avance Rápido

M = Motor programador

M1 = Micro programador marcha

M2 = Micro programador lavado

M3 = Micro programador aclarado

M4 = Micro programador Avance 90°

L3 = Lámpara de ciclo

MBL = Motobomba lavado

C = Condensador de motobomba

V = Válvula de llenado y aclarado

Ds Det = Dosificador de detergente (opcional)

EB = Electrobomba de presifón (opcional)

Esquema teorico adhesivo		Papel adhesivo
N°	Pieza	Cant. Material
N°	Modificacion	Propuesta de
①	Introducir denominación FI-72 T	Palacio
Firma		
S. N.		Fecha
28-9-95		
Dibujado		
Proyectado		
Comprobado		
Escala		
Fagor Industrial, Koo		
LAVAVAJILLAS		
Plano hau ez daiteke erabil ez berzizta gure boizenizt gobe		

3N ÷ 380/415V.

3 ÷ 220V.

1N ÷ 220 V./ 1N ÷ 240V.

FI - 64 B

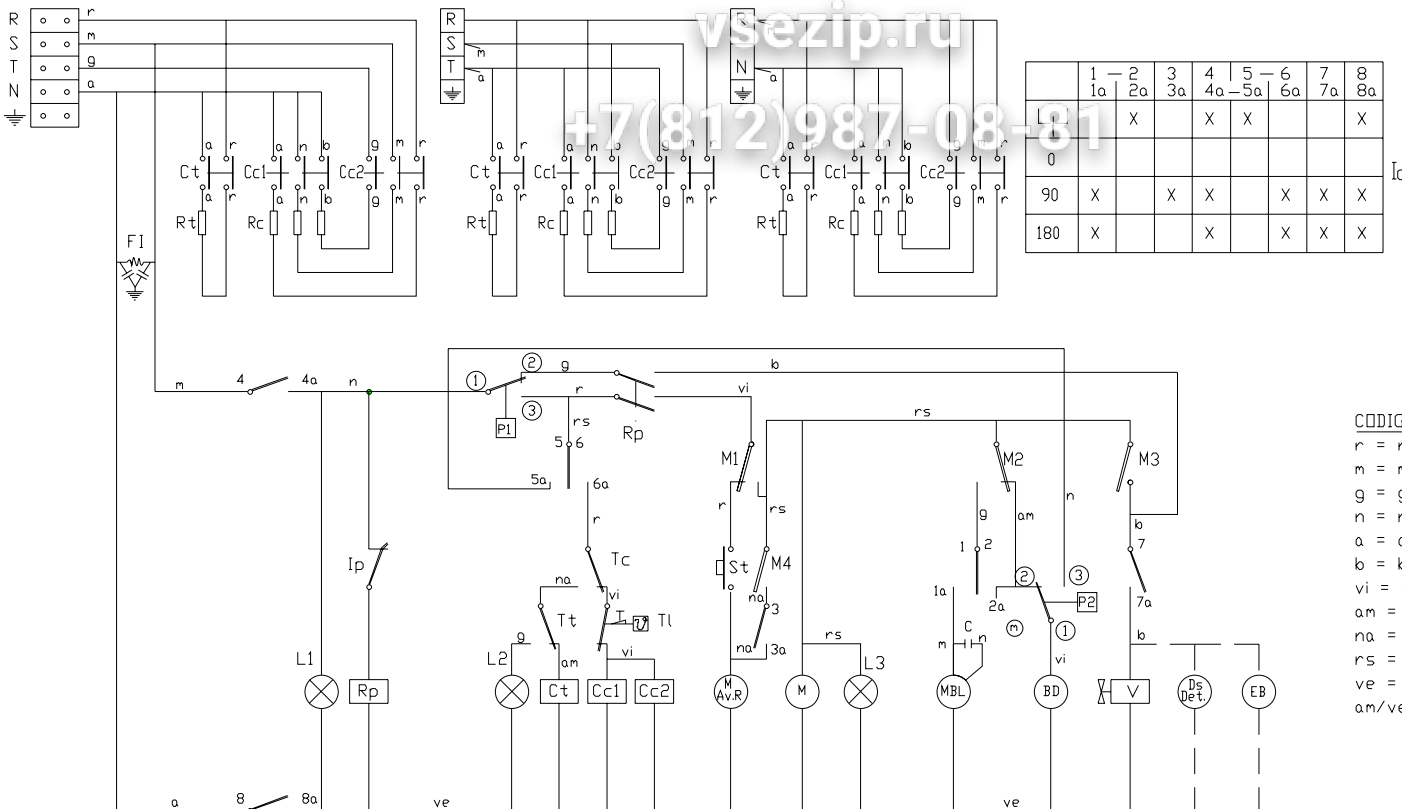

	1 1a	2 2a	3 3a	4 4a	5 5a	6 6a	7 7a	8 8a
L		X		X	X			X
0			X	X		X	X	X
90	X		X	X		X	X	X
180	X		X	X		X	X	X

CODIGO DE COLOR

- r = rojo-red-rou
- m = marron-brow
- g = gris-grey-gr
- n = negro-black
- a = azul-blue-ble
- b = blanco-white
- vi = violeta-viole
- am = amarillo-yel
- na = naranja-or
- rs = rosa-rose
- ve = verde-gree
- am/ve = amarillo

- IG = Interruptor General
- L1 = Lampara de marcha
- Ip = Micro de puerta
- Rp = Relé puerta
- P1 = Presostato
- Tc = Termostato calderin
- Tt = Termostato tanque
- Tl = Termostato limitador de calderin
- Cc1, Cc2 = Contactor calderin
- Ct = Contactor tanque
- L2 = Lampara máquina preparada
- Rc = Resistencia calderin
- St = Pulsador de marcha
- FI = Filtro de interferencias
- BD = Bomba de Desagie

- Rt = Resistencia tanque
- M.Av.R = Motor programador Avance RÁpido
- M = Motor programador
- M1 = Micro programador marcha
- M2 = Micro programador lavado
- M3 = Micro programador aclarado
- M4 = Micro programador Avance 90°
- L3 = Lámpara de ciclo
- MBL = Motobomba lavado
- C = Condensador de motobomba
- V = Válvula de llenado y aclarado
- Ds Det = Dosificador de detergente (opcional)
- P2 = Presostato de seguridad
- EB = Electrobomba de presión (opcional)

Esquema teórico adhesivo		Papel adhesivo	
N°	Pieza	Cant.	Material
N°	Modificación	Propuesta de	
Firma		Fecha	
Dibujado		S. N.	
Proyectado		28-9-95	
Comprobado		FAGOR	
Escala		Fagor Industrial, Koop	
LAVAVAJILLAS			
Plano hau ez daiteke erabil ez berrizta gure bainemitz gabe			

Зип Общежит

FI - 48 B SHARPLINE

vsezip.ru

+7(812)987-08-81

1N ÷ 240V.

3N ÷ 380 - 415 V.

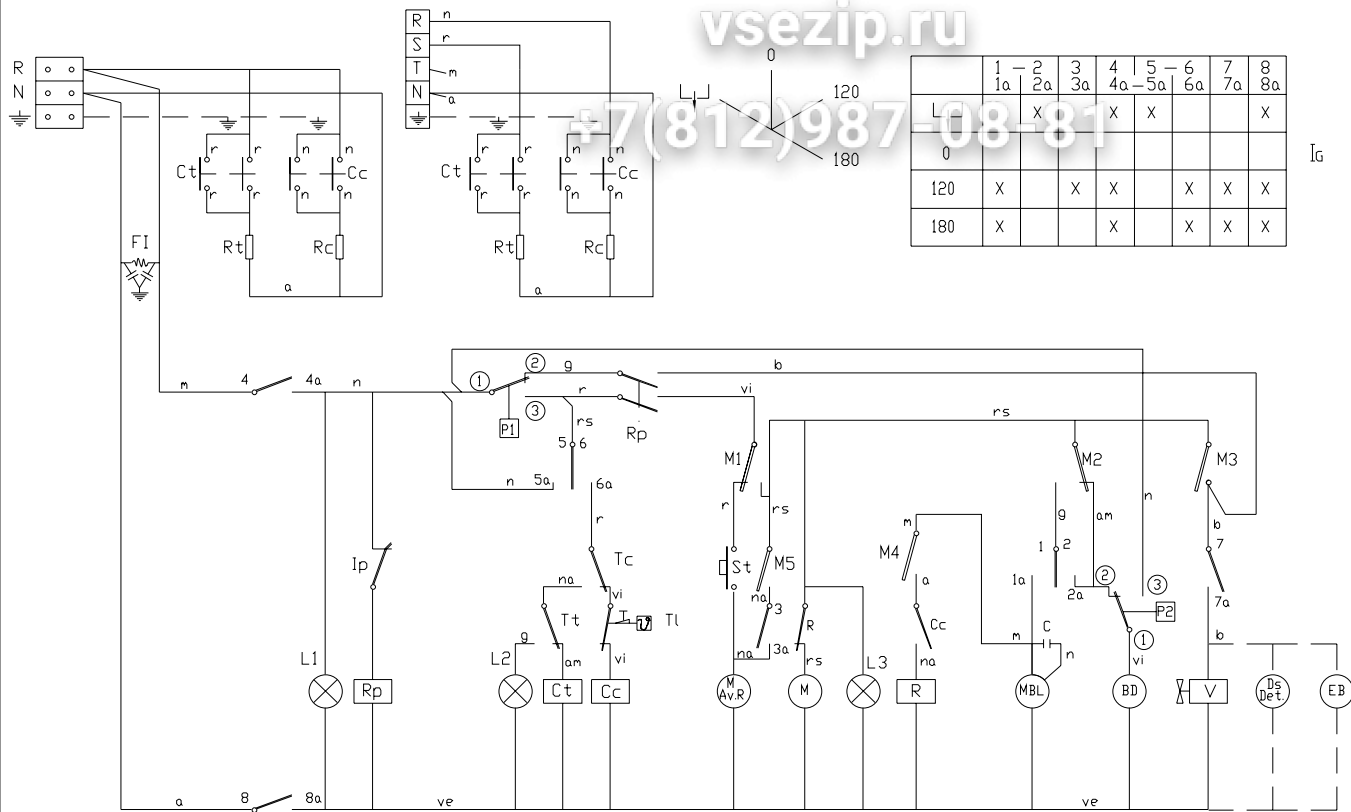

	1 - 2	3	4	5 - 6	7	8
	1a	2a	3a	4a - 5a	6a	7a
L	X		X	X		X
0						
120	X		X		X	X
180	X		X		X	X

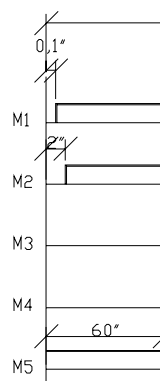

CODIGO DE
 r = rojo-rojo
 m = marron
 g = gris-gris
 n = negro
 a = azul-azul
 b = blanco
 vi = violeta
 am = amarillo
 na = naranja
 rs = rosa
 ve = verde
 am/ve = amarillo/verde

NOTAS:-
 - Fondo
 - Graba
 - Dimens
 - N° Cla

- IG = Interruptor General
- L1 = Lampara de marcha
- Ip = Micro de puerta
- Rp = Relé puerta
- P1 = Presostato
- Tc = Termostato calderin
- Tt = Termostato tanque
- TI = Termostato limitador de calderin
- Cc = Contactor calderin
- Ct = Contactor tanque
- L2 = Lampara máquina preparada
- Rc = Resistencia calderin
- St = Pulsador de marcha
- FI = Filtro de interferencias
- BD = Bomba de Desagie
- R = Relé termo-stop

- Rt = Resistencia tanque
- M.Av.R = Motor programador Avance Rápido
- M = Motor programador
- M1 = Micro programador marcha
- M2 = Micro programador lavado
- M3 = Micro programador aclarado
- M4 = Micro programador impulso dosif. abrillantado
- M5 = Micro programador Avance 120"
- L3 = Lámpara de ciclo
- MBL = Motobomba lavado
- C = Condensador de motobomba
- V = Válvula de llenado y aclarado
- Ds Det = Dosificador de detergente (opcional)
- P2 = Presostato de seguridad
- EB = Electrobomba de presifón (Opcional)

Esquema teorico adhesivo		Papel adhesivo
N°	Pieza	Cant. Material
N°	Modificacion	Propuesta de
Firma		Fecha
S. N.		9-1-98
Dibujado		FAGOR
Proyectado		
Comprobado		
Escala		Fagor Industrial, Koop
LAVAVAJILLAS		
Plano hau ez daiteke erabili ez berrizta gure bainamintz gabe		

Зип Общепит

Mods.: FI-48 W ; MF-48

vsezip.ru

+7(812)987-08-81

208-220-240 V. 1Ph

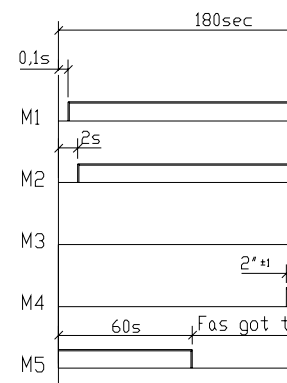
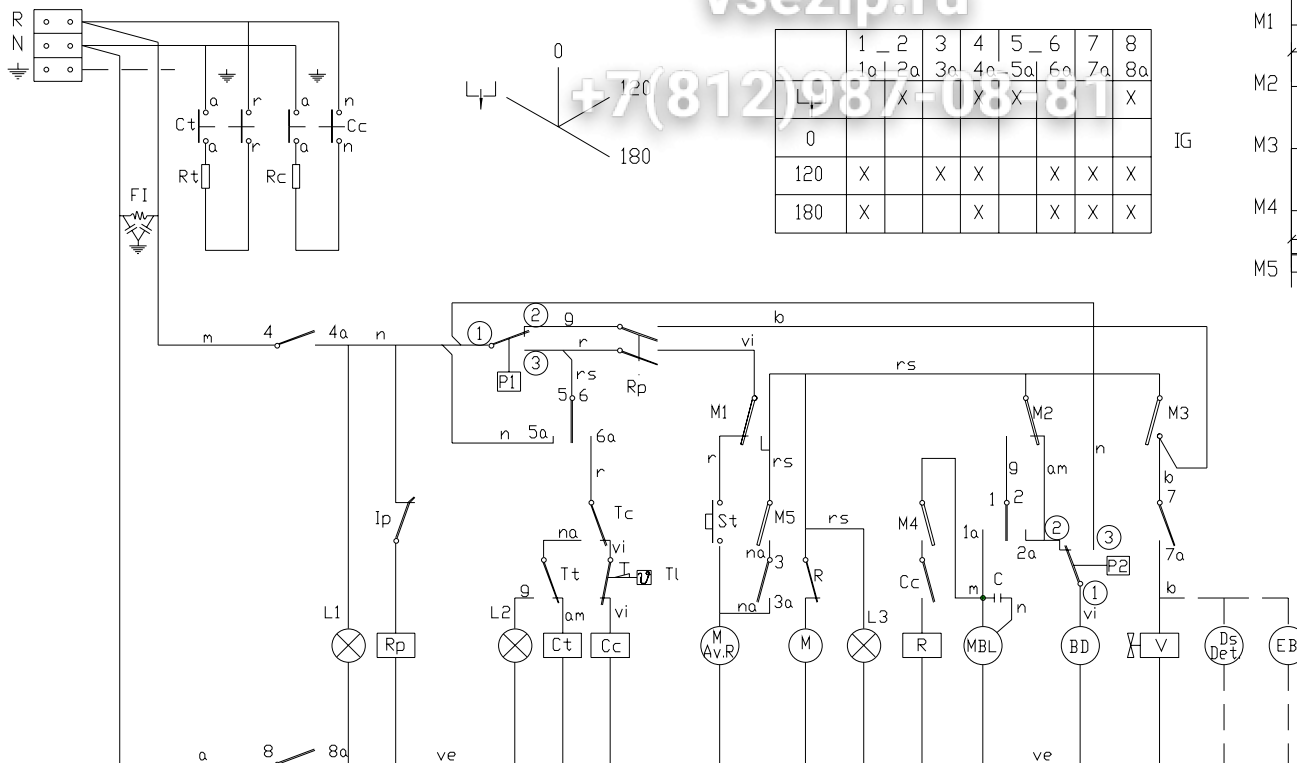

Colours code-Code
 r = red-rouge-rouge
 m = brown-marron
 g = grey-gris-gris
 n = black-noir-ner
 a = blue-bleu-azu
 b = white-blanc-bl
 vi = violette-viole
 am = yellow-jaune
 na = orange-oran
 rs = rose-pink-ro
 ve = green-vert-ve
 am/ve = yellow gr

Ig = General switch	Interrupteur general	Interruptor General
L1 = On lamp	T&Ain de marche	Lampara de marcha
Ip = Door micro	Micro de porte	Micro de puerta
Rp = Door relay	Relais de porte	Rel&A puerta
P1 = Pressure switch	Presostat	Presostato
Tc = Drum thermostat	Thermostat du surchauffeur	Termostato calderin
Tt = Tank thermostat	Thermostat de cuve	Termostato tanque
Tl = Drum limiter thermostat	Thermostat limitateur du surchauffeur	Termostato limitador de calderin
Cc = Drum contactor	Contacteur du surchauffeur	Contactor calderin
Rc = Drum heating element	Resistance du surchauffeur	Resistencia calderin
L2 = Machine ready light	T&Ain de marche prepar&e	Lampara mAquina preparada
St = Start button	Bouton de marche	Pulsador de marcha
FI = Interferences filter	Filtre d'interferences	Filtro de interferencias
BD = Drain pump	Pompe de vidange	Bomba de Desagie

Rt = Tank heating element	Resistance de cuve	Resistencia de cuve
M.A.V.R = Motor programmer rapid advance	Moteur du programm. d'avancement rapide	Motor programador avance rapido
M = Motor programmer	Moteur du programmeur	Motor programador
M1 = Micro programmer on	Micro du programm. de marche	Micro programador de marcha
M2 = Micro programmer wash	Micro du programm. de lavage	Micro programador de lavado
M3 = Micro programmer rinse	Micro du programm. de rincage,	Micro programador de aclarado
M4 = Micro programmer Thermo-Stop	Micro du programador Thermo-Stop	Micro programador Thermo-Stop
M5 = Micro programmer 120' advance	Micro programador Avance 120'	Micro programador Avance 120'
L3 = Cycle light	T&Ain de cycle	L&Ampara de ciclo
MBL = Motor pump wash	Motobpompe de lavage	Motobombina de lavado
C = Motor pump condenser	Condensateur de la motopompe	Condensador de la motobombina
V = Filling and rinsing valve	Valve de remplisage et de vidange	VALVULA de llenado y aclarado
Ds Det = Detergent dispenser (Optional)	Doseur de detergent (Option)	Dosificador de detergente (Opcion)
P2 = Safety pressure switch	Presostat de s&Acurit&A	Presostato de seguridad
EB = Electric pressure pump (Optional)	Electropompe de pression (Option)	Electrobombina de presion (Opcion)

Зип Общежит

FI - 48-B-A

vsezip.ru

+7(812)987-08-81

1N + 240V.

3N + 380 - 415 V.

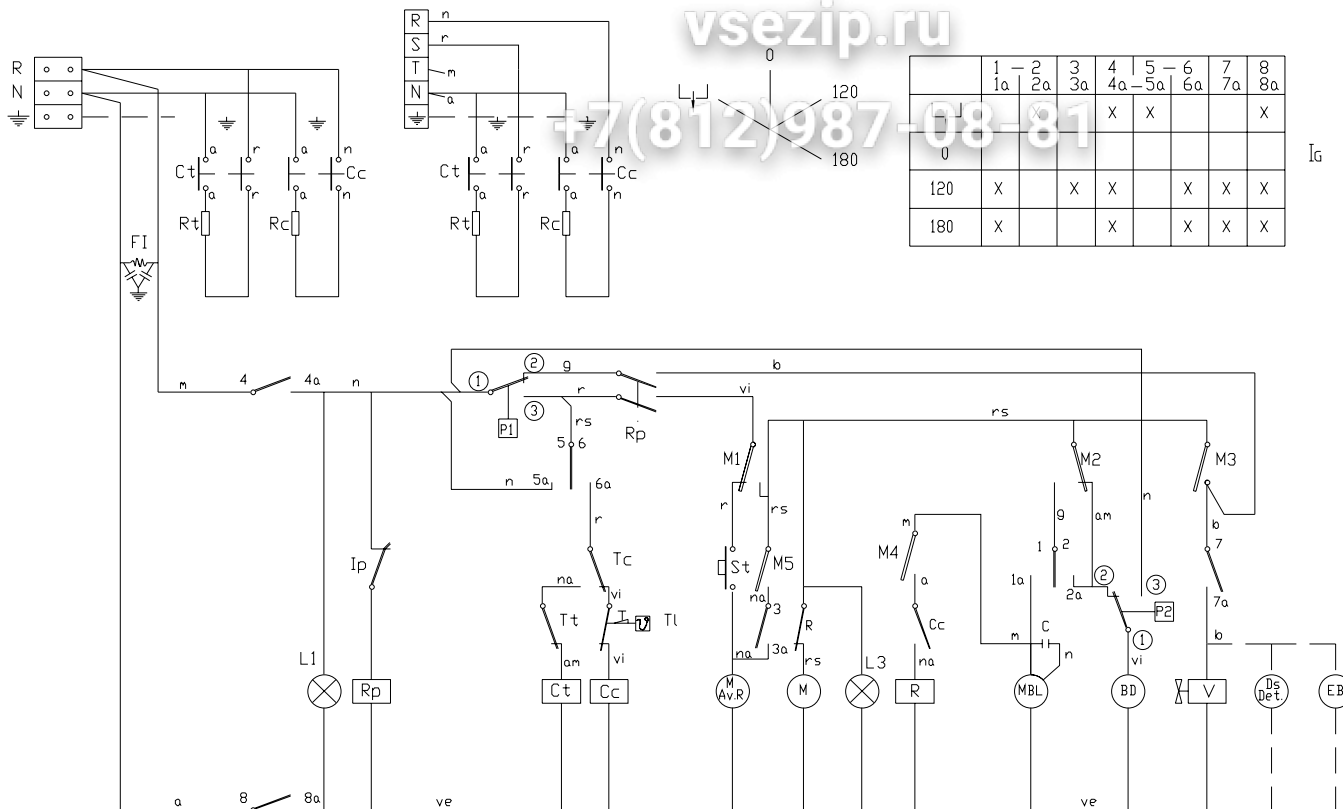

	1-1a	2-2a	3-3a	4-4a	5-5a	6-6a	7-7a	8-8a
0	X		X	X		X	X	X
120	X		X	X		X	X	X
180	X		X	X		X	X	X

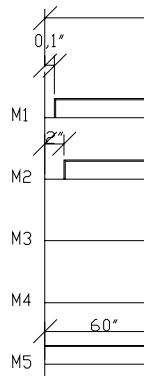

CODIGO DE
 r = rojo
 m = marrón
 g = gris
 n = negro
 a = azul
 b = blanco
 vi = violeta
 am = amarillo
 na = naranja
 rs = rosa
 ve = verde
 am/ve = ...

NOTAS:
 - Fondo
 - Grak
 - Dimer
 - N° C

- I_G = Interruptor General
- L1 = Lampara de marcha
- I_p = Micro de puerta
- R_p = Relé puerta
- P1 = Presostato
- T_c = Termostato calderin
- T_t = Termostato tanque
- Tl = Termostato limitador de calderin
- C_c = Contactor calderin
- C_t = Contactor tanque
- L2 = Lampara máquina preparada
- R_c = Resistencia calderin
- St = Pulsador de marcha
- FI = Filtro de interferencias
- BD = Bomba de Desagüe
- R = Relé termo-stop

- R_t = Resistencia tanque
- M.A.v.R = Motor programador Avance Rápido
- M = Motor programador
- M1 = Micro programador marcha
- M2 = Micro programador lavado
- M3 = Micro programador aclarado
- M4 = Micro programador impulso dosif. abrigillatado
- M5 = Micro programador Avance 120°
- L3 = Lámpara de ciclo
- MBL = Motobomba lavado
- C = Condensador de motobomba
- V = VALVULA de llenado y aclarado
- Ds Det = Dosificador de detergente (opcional)
- P2 = Presostato de seguridad
- EB = Electrobomba de presión (Opcional)

Esquema teorico adhesivo		Papel adhe
N°	Pieza	Cant. Material
N°	Modificacion	Propuesta de
①	Eliminar Piloto L2	J.M.P.
Firma		Fecha
Dibujado S. N.		28-9-95
Proyectado		FAGOR
Comprobado		Fagor Industrial, Ko
Escala		
LAVAVAJILLAS		
Plano hau ez daiteke erabil ez berrizta gure baimenitz gabe		

Зип Общежит

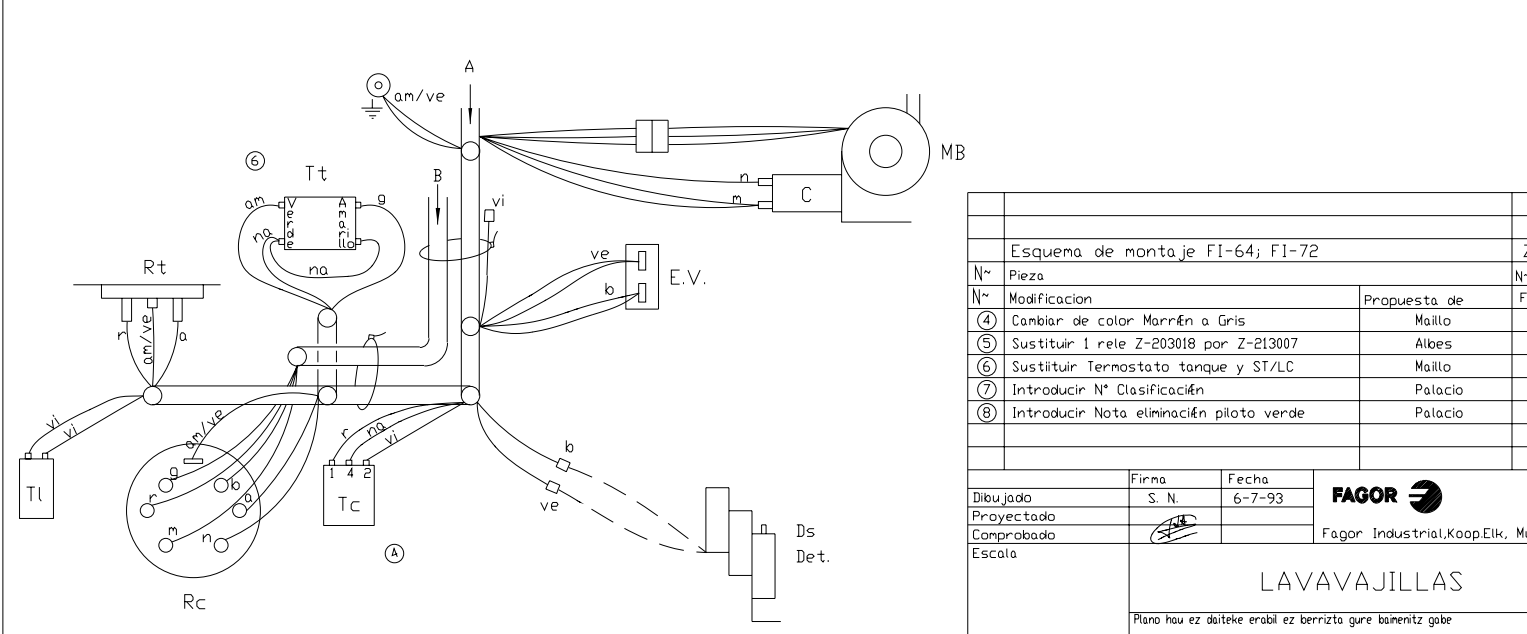
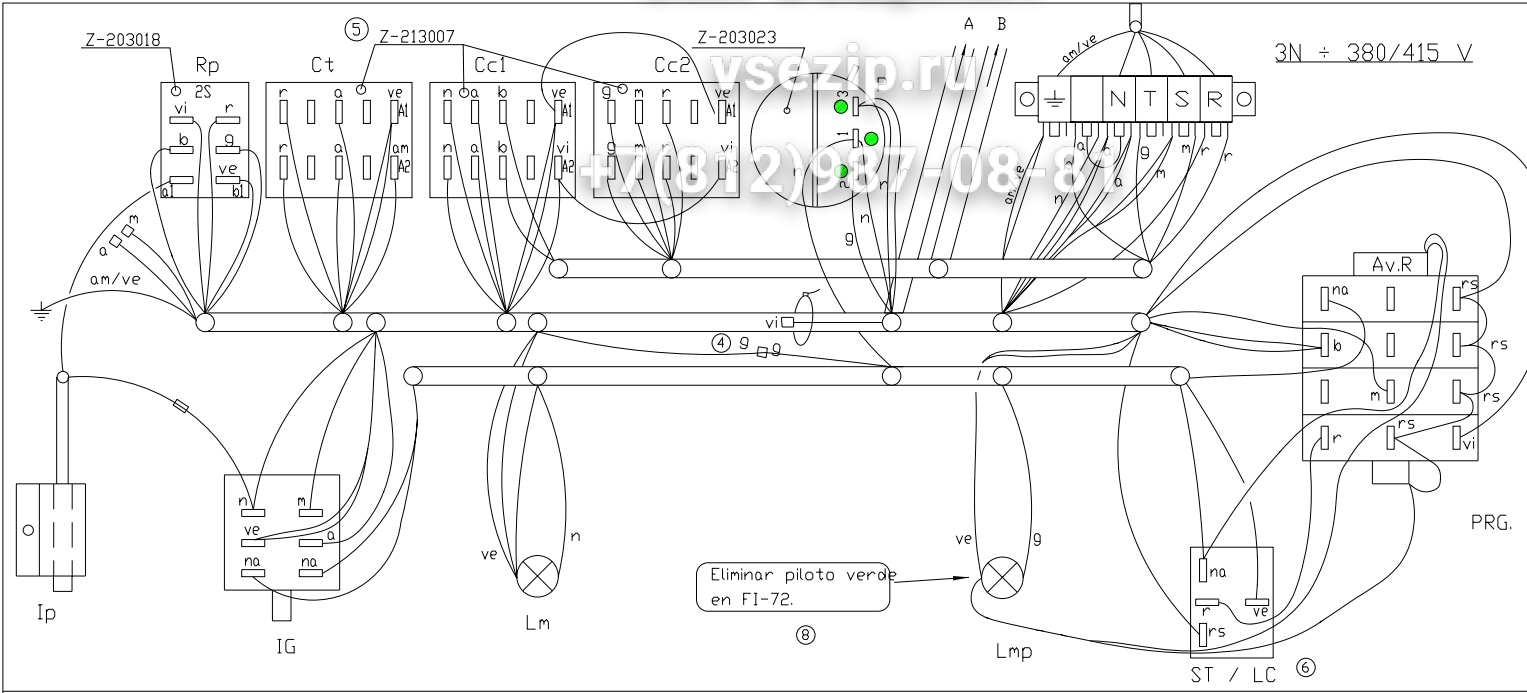

Esquema de montaje FI-64; FI-72		
Nº	Pieza	Nº
Nº	Modificación	Propuesta de
④	Cambiar de color Marrón a Gris	Maíto
⑤	Sustituir 1 rele Z-203018 por Z-213007	Albes
⑥	Sustituir Termostato tanque y ST/LC	Maíto
⑦	Introducir N° Clasificación	Palacio
⑧	Introducir Nota eliminación piloto verde	Palacio

Dibujado	Firma	Fecha	 Fagor Industrial, Koop, Elk, M...
Proyectado	S. N.	6-7-93	
Comprobado			
Escola			
LAVAVAJILLAS			
Plano hau ez daiteke erabili ez berritza gure baimenitz gabe			

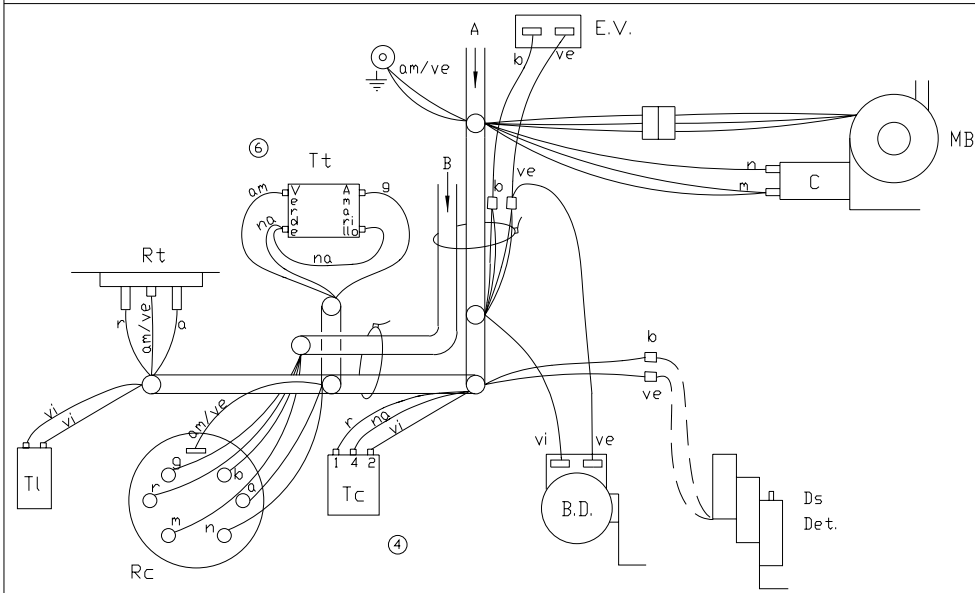
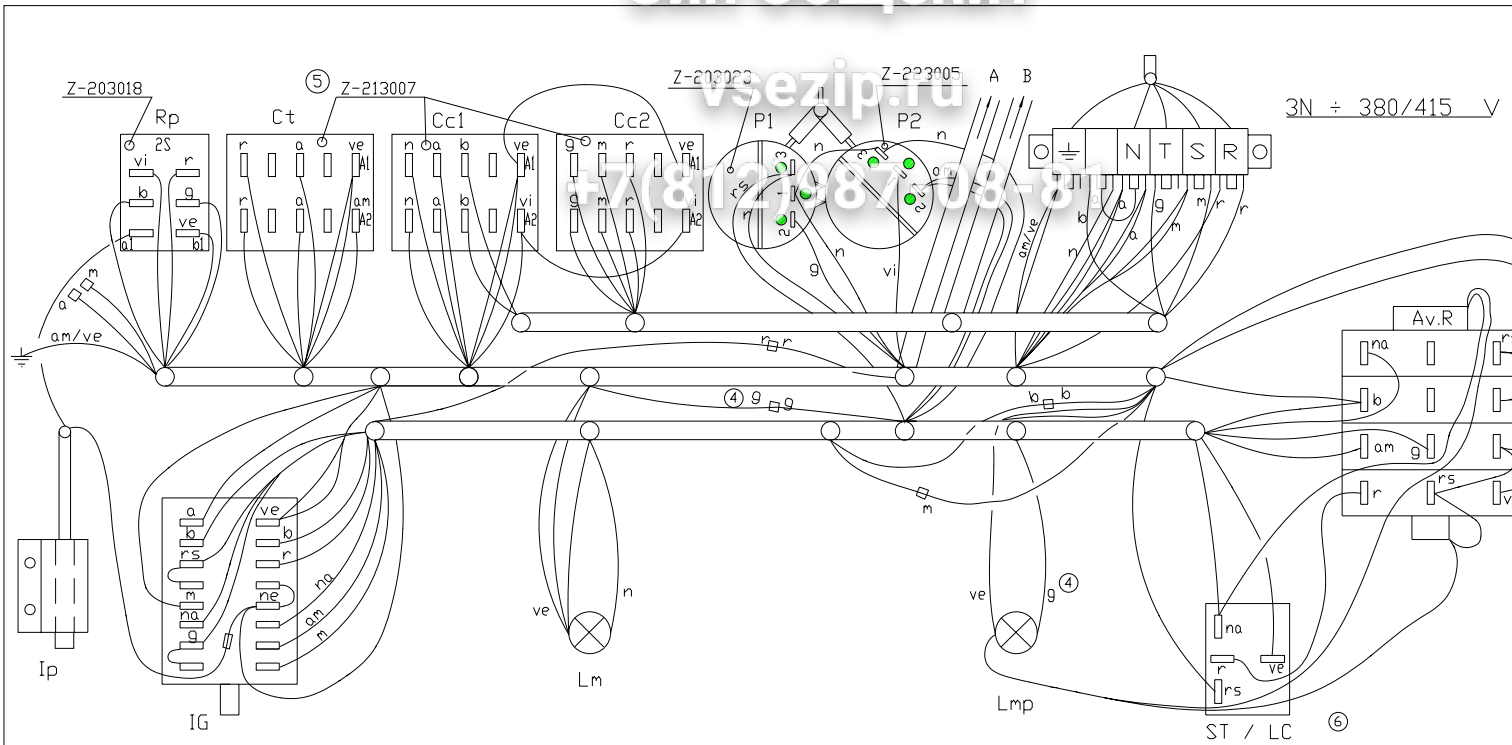

Nº	Pieza	Cant.	Material
Esquema de montaje FI-64 B			
Nº	Modificación		Propuesta de
⑥	Sustituir Termostato tanque y ST/LC		Maillo
⑦	Introducir N° Clasificación		Palacio
③	Introd. versión IN:220V, pasar colores gris y marrón a rojo y rojo		Albes
④	Cambiar de color Marrón a Gris		Maillo
⑤	Sustituir 1 relé Z-203018 por Z-213007		Albes
Dibujado	Firma	Fecha	 Fagor Industrial, Koop. Elk.
Proyectado	S. N.	12-7-93	
Comprobado			
Escala			
LAVAVAJILLAS			
Plano hau ez duteke erabil ez berrizta gure baimenitz gabe			

usezip.ru
+7(812)987-08-81

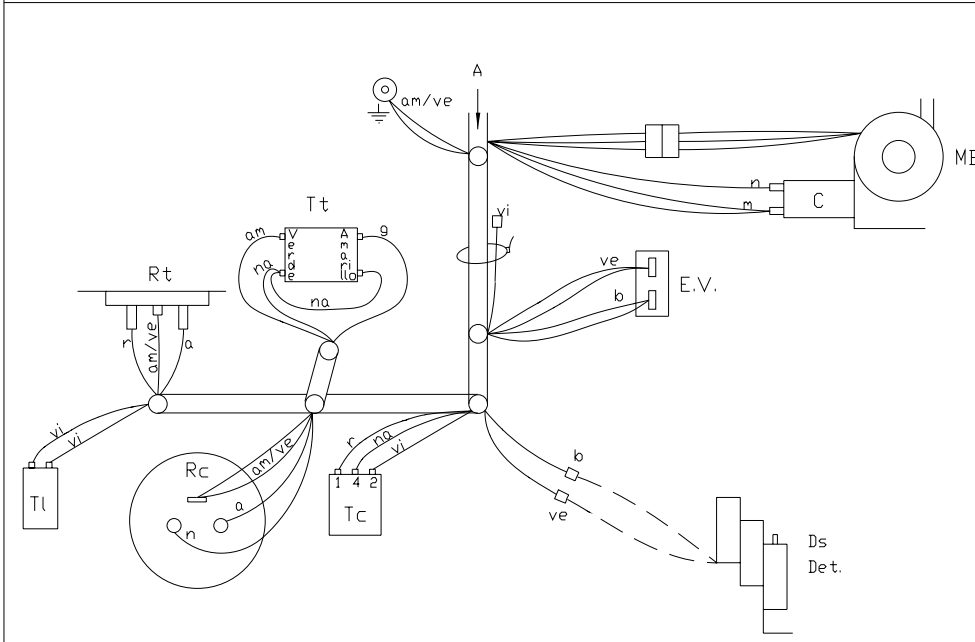
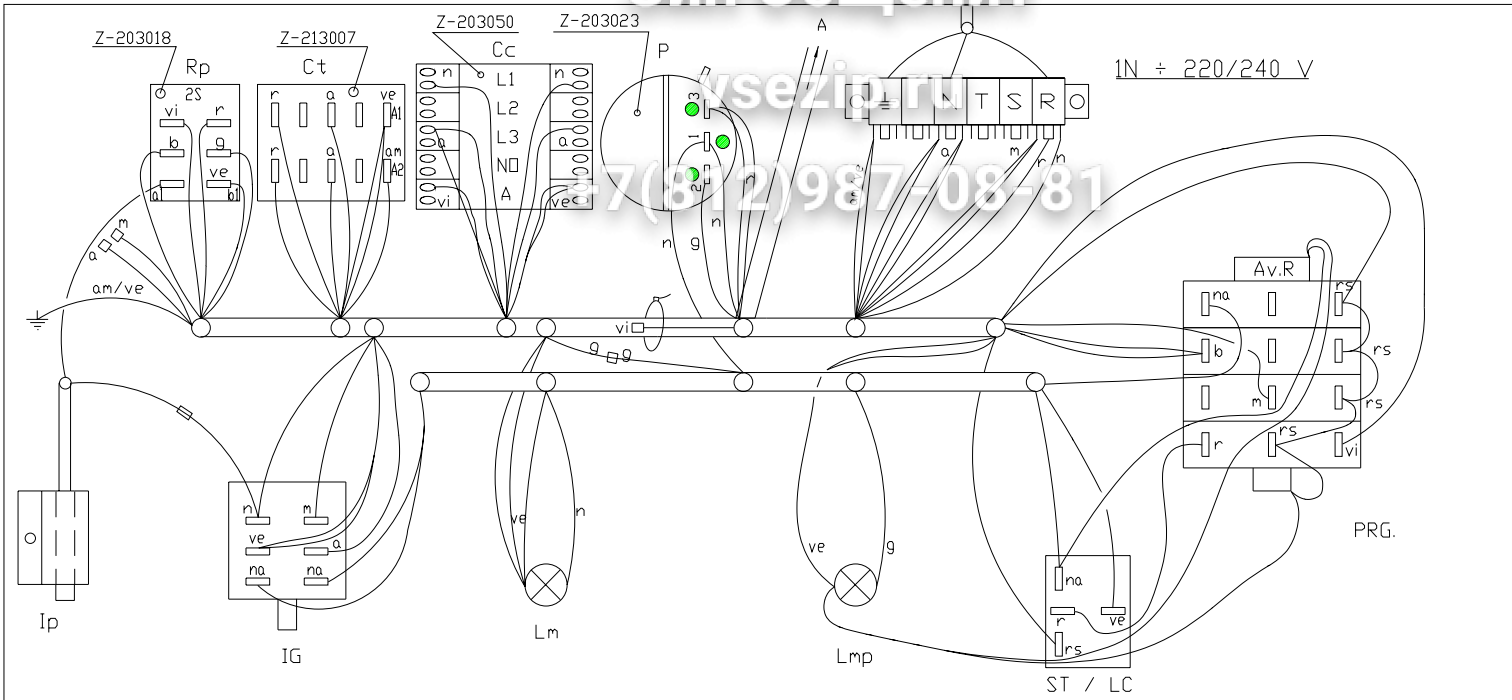

Esquema de montaje FI-48		
Nº Pieza		Material
Nº Modificación		Propuesta de
Dibujado		Firma
Projectado		Fecha
Comprobado		Santi Caro 05-07-00
Escala		FAGOR
Fagor Industrial, Koop. E.		
<h2>LAVAVAJILLAS</h2>		
Plano hau ez daiteke erabil ez berritza gure boimenitz gabe		

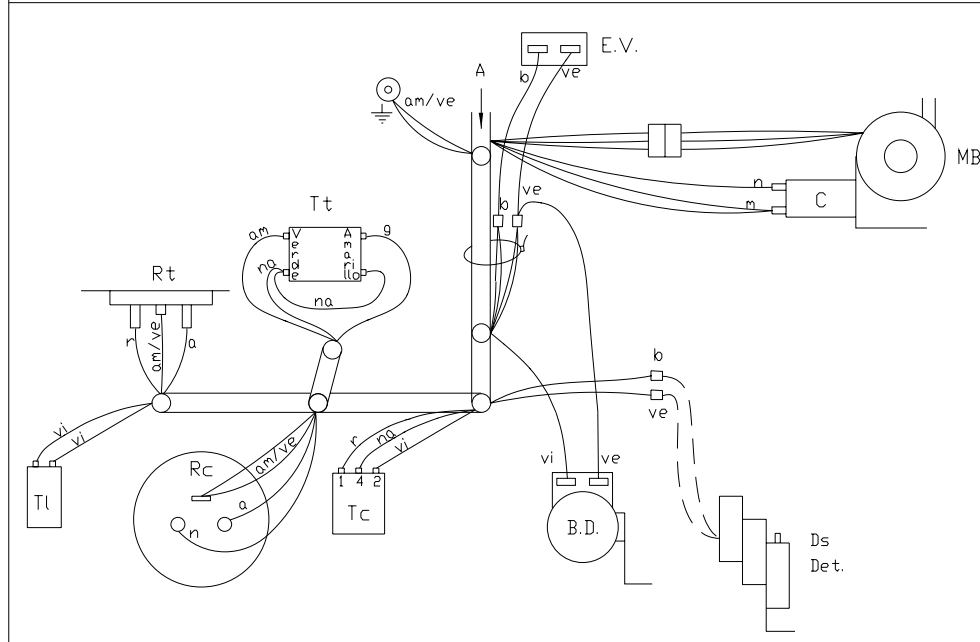
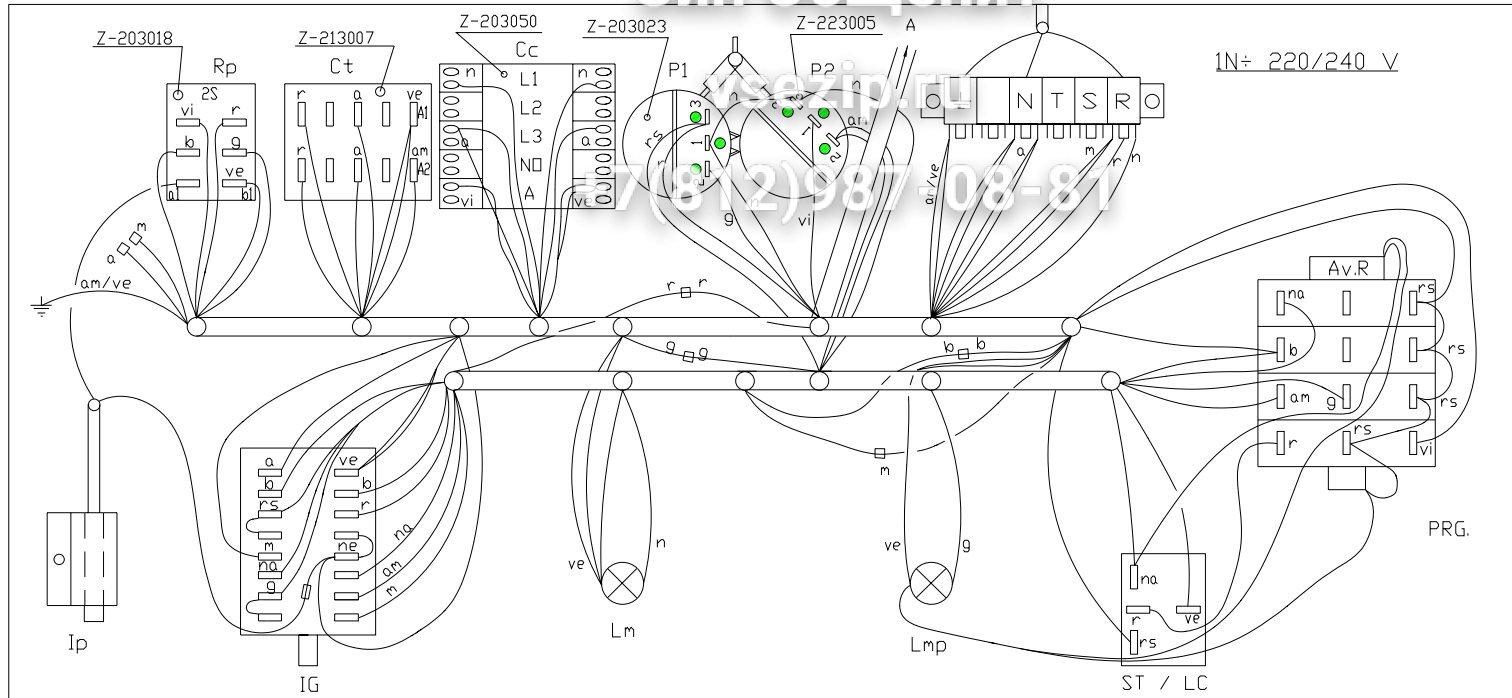

Esquema de montaje FI-48b			
N~	Pieza	Cant.	Material
N~	Modificacion	Propuesta de	
Dibujado	Firma	Fecha	 Fagor Industrial.Koop.Elk
Proyectado	Santi Caro	07-07-00	
Comprobado			
Escala			
LAVAVAJILLAS			
Plano hau ez daiteke erabil ez berrizta gure baimenitz gabe			

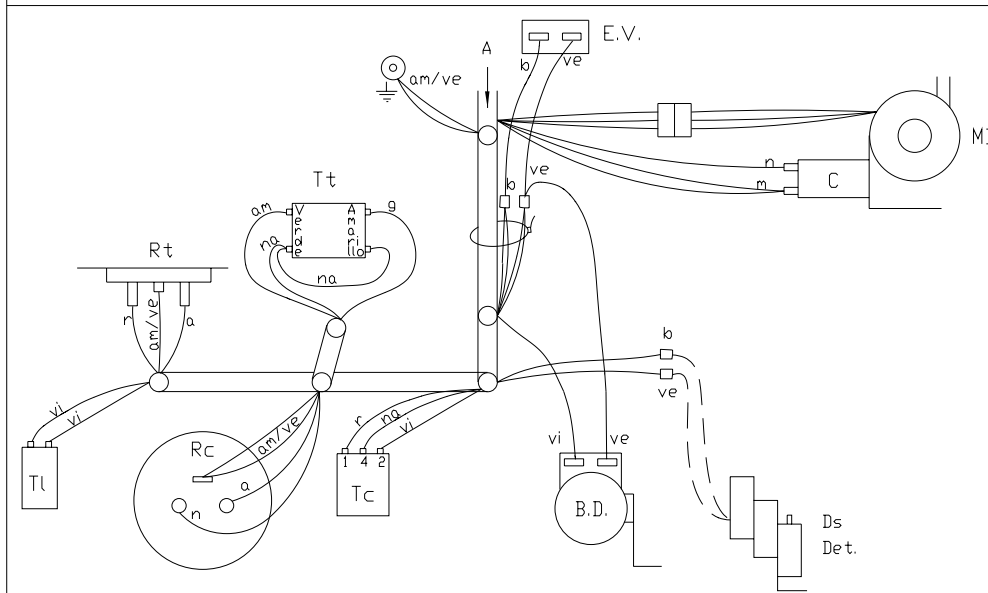
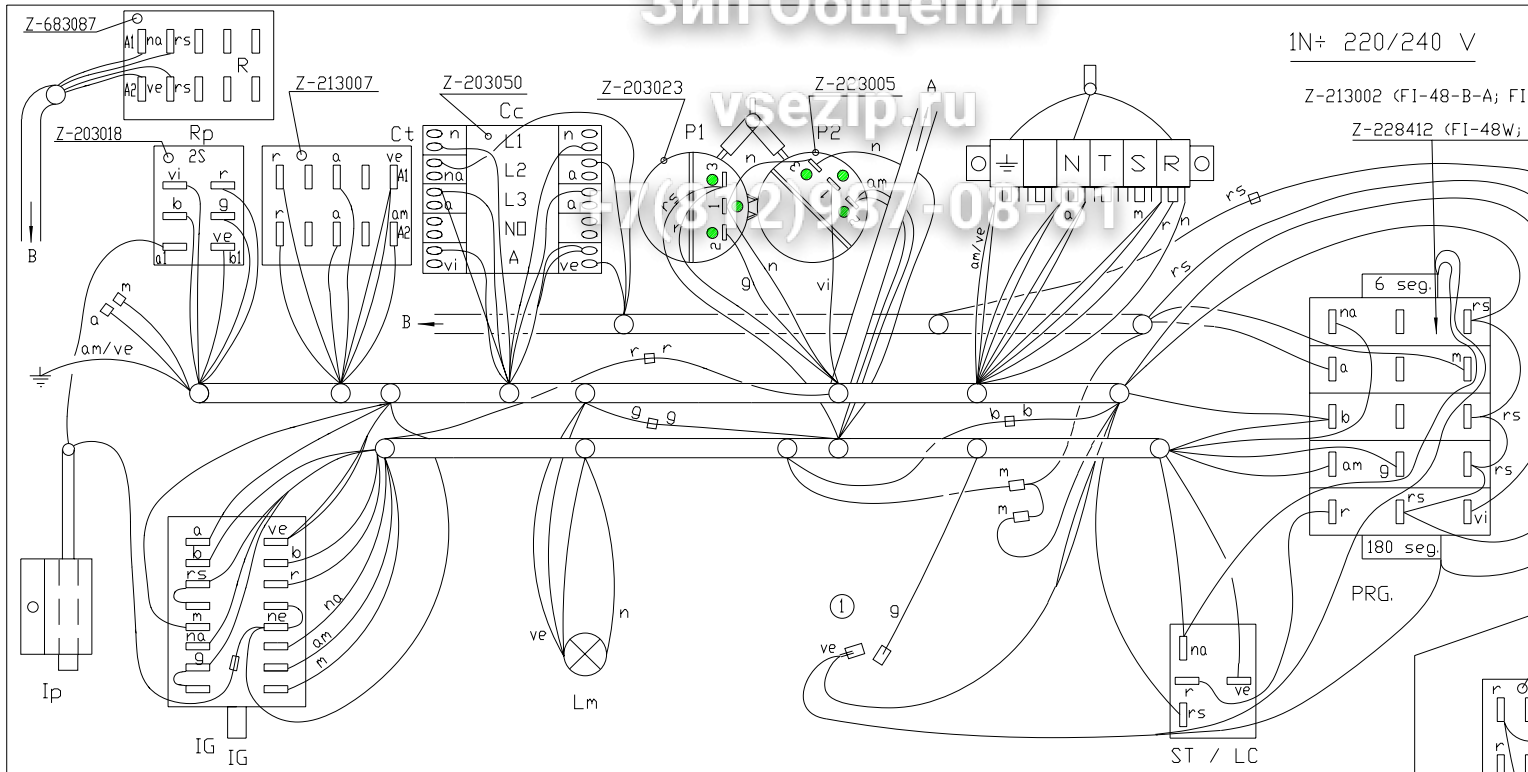

	Esquema de montaje FI-48W, MF-48	
	Esquema de montaje FI-48B SHARPLINE	
	Esquema de montaje FI-48-B-A	
Nº	Pieza	Material
Nº	Modificacion	Propuesta de
①	Eliminar piloto verde LMP.	J.M.P.

	Firma	Fecha	 Fagor Industrial, Koop.
Dibujado	Santi Caro	07-07-00	
Proyectado			
Comprobado			
Escala			LAVAVAJILLAS Plano hau ez daiteke erabil ez berritza gure baimenitz gabe

Зип Общепит

MF-64 ; FI-64 W ; FI-64-B-A

vsezip.ru

+7(812)987-09-81

208-220-240 V. 3Ph

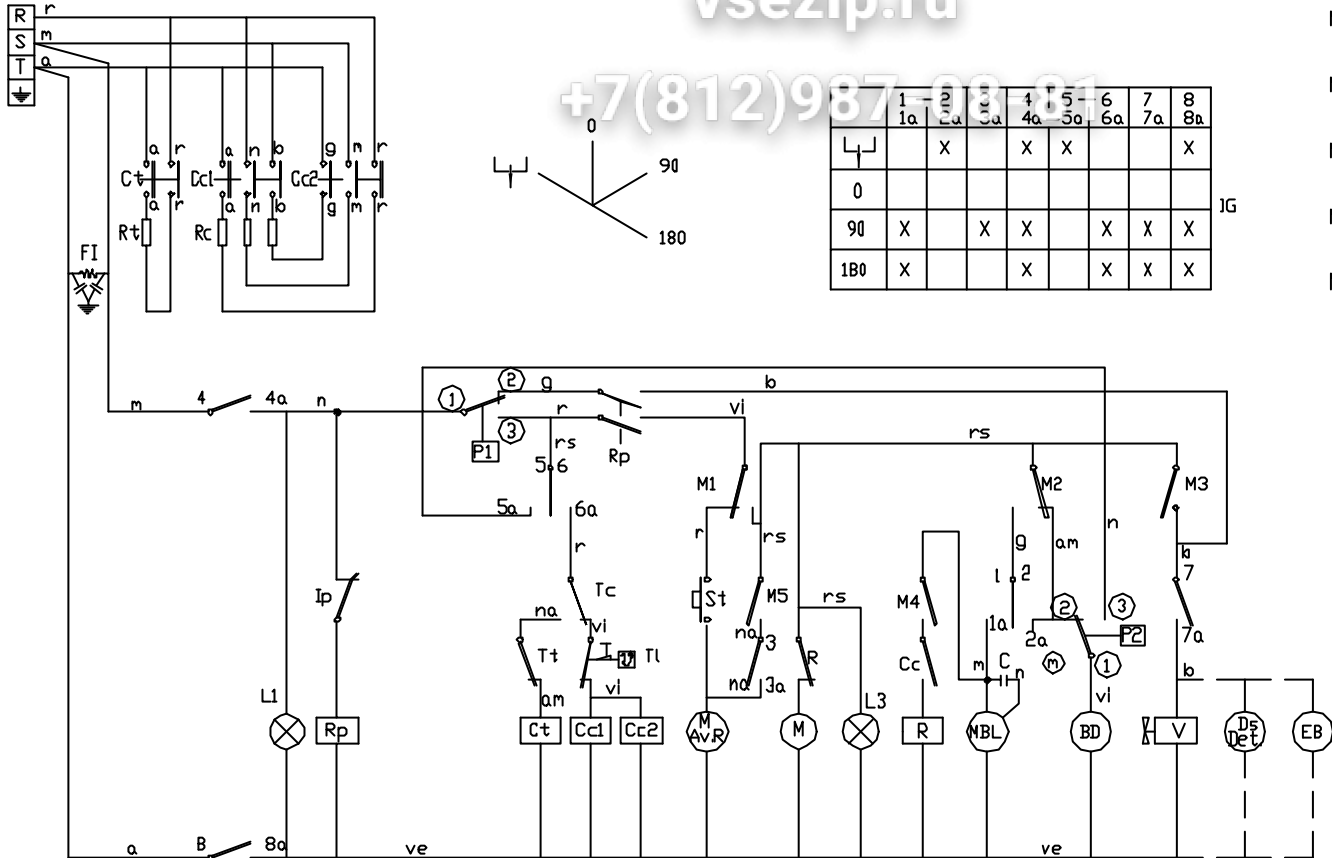

	1 1a	2 2a	3 3a	4 4a	5 5a	6 6a	7 7a	8 8a
90		X		X	X			X
180	X		X	X		X	X	X

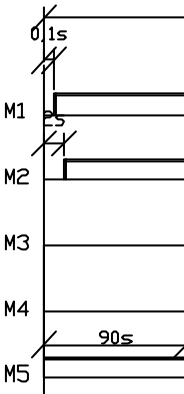

Colours c
r = red-r
m = brown
g = grey-
n = black
a = blue-
b = white
vi = violet
am = yellow
na = orange
rs = rose
ve = green
am/ve = yellow/green

IG = General switch
L1 = On lamp
Ip = Door micro
Rp = Door relay
P1 = Pressure switch
Tc = Drum thermostat
Tt = Tank thermostat
TI = Drum limiter thermostat
Cc1, Cc2 = Drum contactor
Ct = Tank contactor
L2 = Machine ready light
Rc = Drum heating element
St = Start button
FI = Interferences filter
BD = Drain pump

Interrupteur general
Tânoin de marche
Micro de porte
Relais de porte
Presostat
Thermostat du surchauffeur
Thermostat de cuve
Thermostat limitateur du surchauffeur
Contacteur du surchauffeur
Contacteur de cuve
Tânoin de machine preparée
Resistance du surchauffeur
Bouton de marche
Filtre d'interferences
Pompe de vidange

Interruptor General
Lampara de marcha
Micro de puerta
Relá puerta
Presostato
Termostato calderin
Termostato tanque
Termostato limitador de calderin
Contactar calderin
Contactar tanque
Lampara Máquina preparada
Resistencia calderin
Pulsador de marcha
Filtro de Interferencias
Bomba de Desagüe

Rt = Tank heating element
MAvR = Motor programmer rapid advance
M = Motor programmer
M1 = Micro programmer on
M2 = Micro programmer wash
M3 = Micro programmer rinse
M4 = Micro programmer Terno-Stop
M5 = Micro programmer 90' advance
L3 = Cycle light
MBL = Motor pump wash
C = Motor pump condenser
V = Filling and rinsing valve
Ds Det = Detergent dispenser (Optional)
P2 = Safety pressure switch
EB = Electric pressure pump (Optional)

Resistance de cuve
Moteur du programm. d' avancement rapide
Moteur du programmeur
Micro du programm. de marche
Micro du programm. de lavage
Micro du programm. de rincage
Micro du programador Terno-Stop
Micro programador Avance 90'
Tânoin de cycle
Motopompe de lavage
Condensateur de la motopompe
Valve de remplissage et de vidange
Doseur de detergent (Option)
Presostat de sécurité
Electropompe de pression (Option)

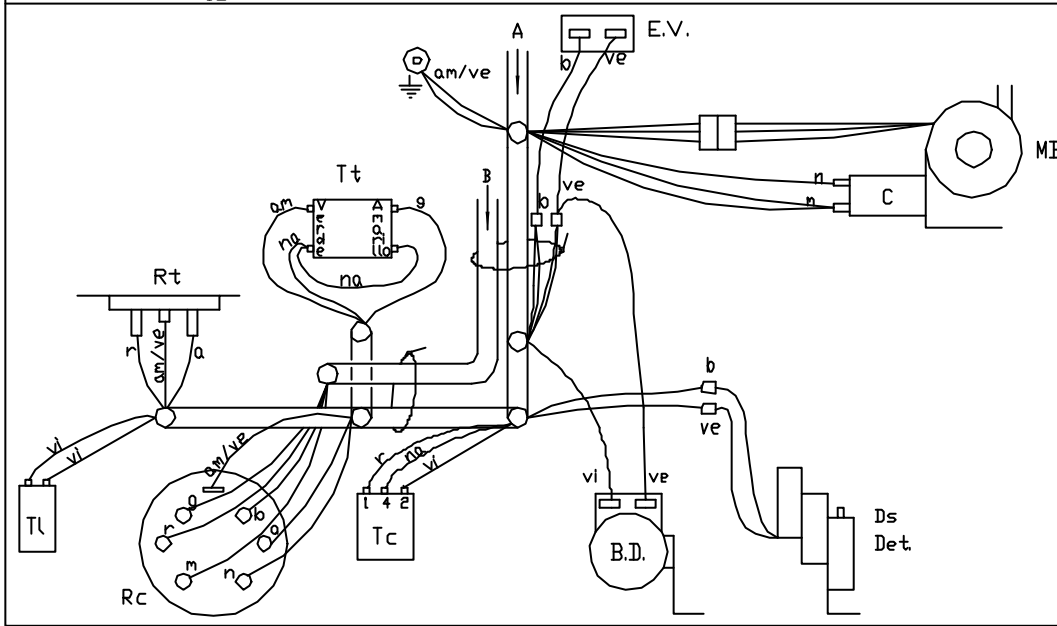
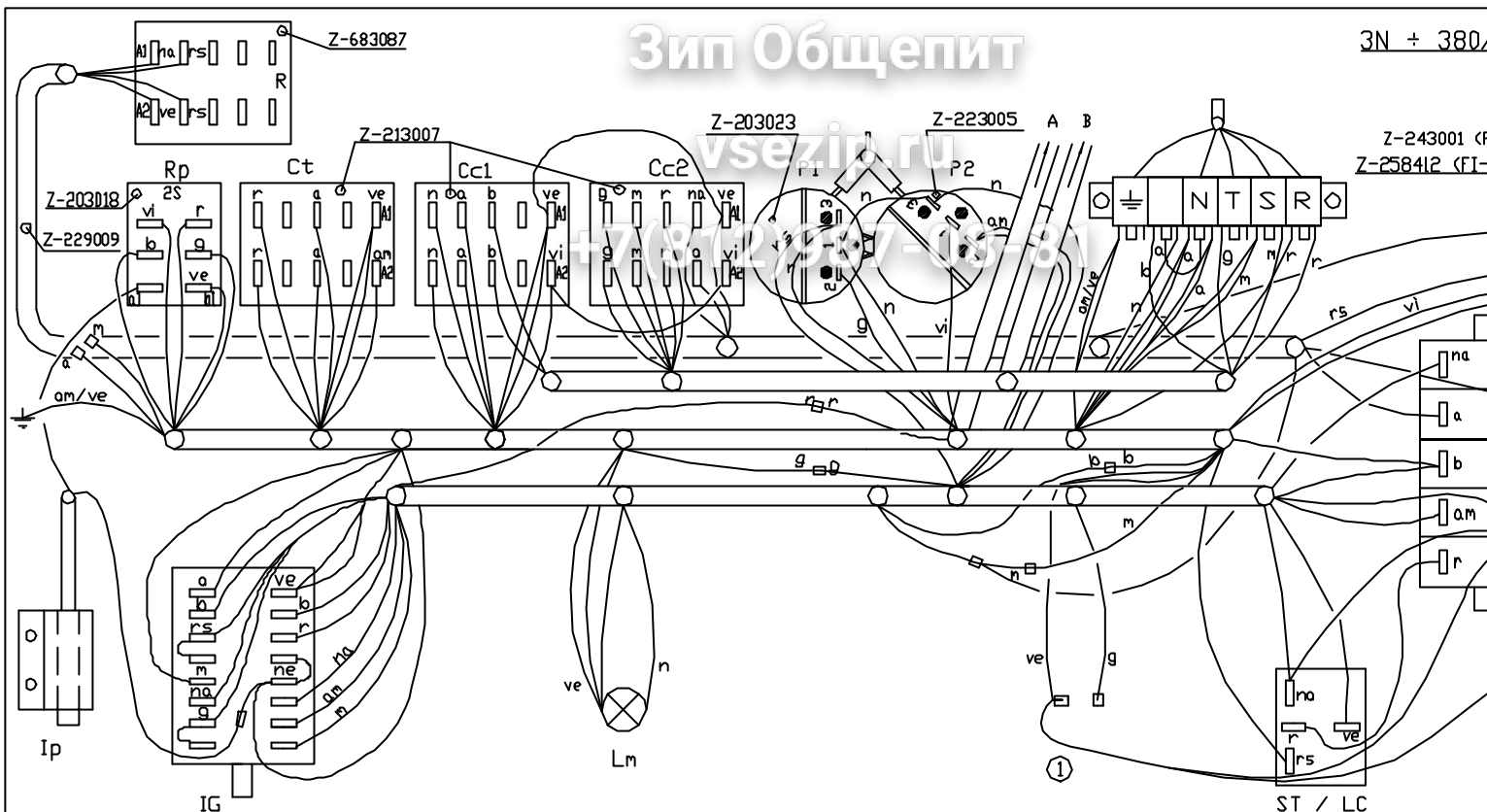

Esquema montaje FI-64 W; NF-64; FI-64-B-A			
Nº	Pieza		
Nº	Modificación		
①	Intrad. Versión FI-64-B-A; eliminar piloto Lmp		
Dibujado		Firma	Fecha
Proyectado		S. N.	24-3-00
Comprado		Fagar Inb	
Escala		LAVAVAJU	
Plano hau ez daterke erabili ez berriete gure bako			