

Зип Общепит

vsezip.ru

+7(812)987-08-81



**030FT**

**Edition 20100127-**

Зип Ощепит

vsezip.ru

+7(812)987-08-81

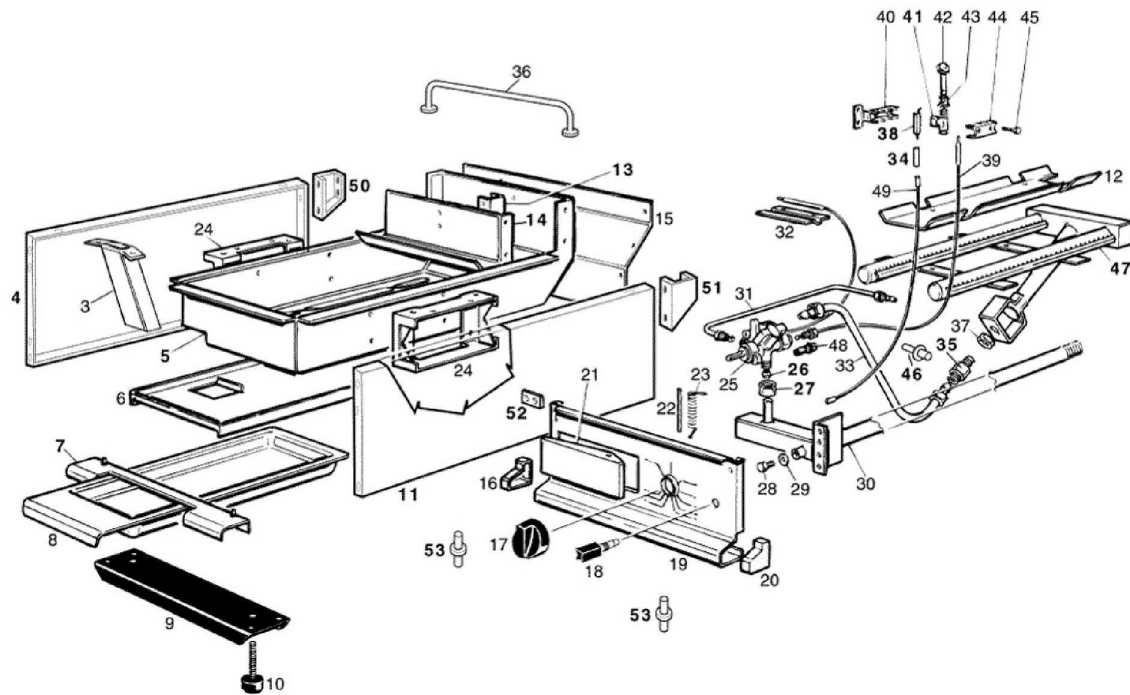
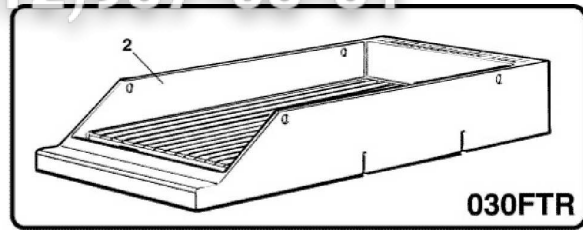
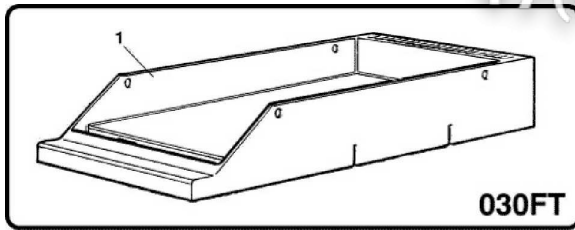

Pos	Code	Description	Info
001	30M3540	SMOOTH PLATE ASS. Y	01/11/1995-
003	3AD0020	CONVEYOR ASS.Y	01/11/1995-
004	35C0590	LH PANEL	01/11/1995-
005	35D8380	EXHAUST FLUE	01/11/1995-
006	3AT0370	CHAMBER TRAY SUPPORT ASS.Y	01/11/1995-
007	35C5140	BRACKET	01/11/1995-
008	35W3200	DRIP TRAY	01/11/1995-
009	30T2531	FOOT HOUSING ASS. Y	01/11/1995-
010	36D2970	ADJUSTABLE FOOT	01/11/1995-
011	35C0600	RH PANEL	01/11/1995-
012	35D4680	FLAME DEFLECTOR	01/11/1995-
013	35V9690	"Z" BRACKET	01/11/1995-
014	35D8390	HALF FLUE FRONT PLATE	01/11/1995-
015	35B2022	REAR PANEL	15/01/1996-
016	36D3430	LH END SIDE	01/11/1995-
017	36M2390	GAS CONTROL KNOB	01/11/1995-
018	32T0130	PIEZO IGNITION	01/11/1995-
019	35B7430	UPPER CONTROL BOARD	01/11/1995-
020	36D3420	RH END SIDE	01/11/1995-
021	35G4260	SLOT COVER	01/11/1995-
022	36G5150	PIN	01/11/1995-
023	36G5180	SPRING	01/11/1995-
024	35Q7710	COMB. CHAMBER SUPPORT	01/11/1995-
025	33A2840	THERMOSTATIC VALVE	01/11/1995-
026	36Q0030	BICONE Ø12X8	01/11/1995-
027	36Q0050	BICONE NUT Ø 12	01/11/1995-
028	31A7380	SCREW TE M5X10	01/11/1995-
029	3128460	WASHER	01/11/1995-
030	30Z8100	GAS MANIFOLD ASS. Y	01/11/1995-
031	35X1690	PILOT LIGHT PIPE	01/11/1995-
032	35V2330	PROBE SUPPORT	01/11/1995-
033	35X1680	PIPE	01/11/1995-
034	131AA46	HOSE 8'X40	01/11/1995-
035	33Q2531	NOZZLE HOUSING	01/11/1995-
036	3600450	FLUE GUARD	01/11/1995-
037	36Q1110	LOCK NUT 3/8"	01/11/1995-
038	32T0010	IGNITION PLUG	27/01/2010-
039	33A0680	THERMOCOUPLE M8X1X600	13/06/2001-
040	33A1000	FRONT BRACKET	01/11/1995-
041	33A2900	PILOT BURNER BODY	01/11/1995-
042	33A1081	THREE-FLAME BURNER	24/04/2008-
043	33A0970	RING NUT	01/11/1995-
044	33A0950	REAR BRACKET	01/11/1995-
045	33A0980	SCREW 3/16W. X18TE	01/11/1995-
046	33A0640	PRESSURE TEST POINT	01/11/1995-
047	34A1551	BURNER	01/11/1995-
048	32Z1520	VALVE MAGNET	01/11/1995-
049	32A0210	CABLE "HF" 700MM	01/11/1995-
050	35Q8290	LEFT HAND PANEL	01/11/1995-
051	35Q8300	RIGHT HAND PANEL	01/11/1995-
052	35T9650	FLAT BRACKET	01/11/1995-

Pos	Code	Description	Info
053	36C2060	CONTROL BOARD PIN	01/11/1995-

ЗипОбщепит

vsezip.ru

+7(812)987-08-81