

Зип Общепит

DESPIECE TECNICO

vsezip.ru

+7(812)987-08-81

Lavavajillas
Lavevaisselle
Dishwasher
Geschirrspüler
Lavastoviglie

Modelos:

AD-90

AD-90 DD

Diciembre 2009 December



Fagor Industrial

Зип Общепит

vsezi.ru

+7(812)987108881

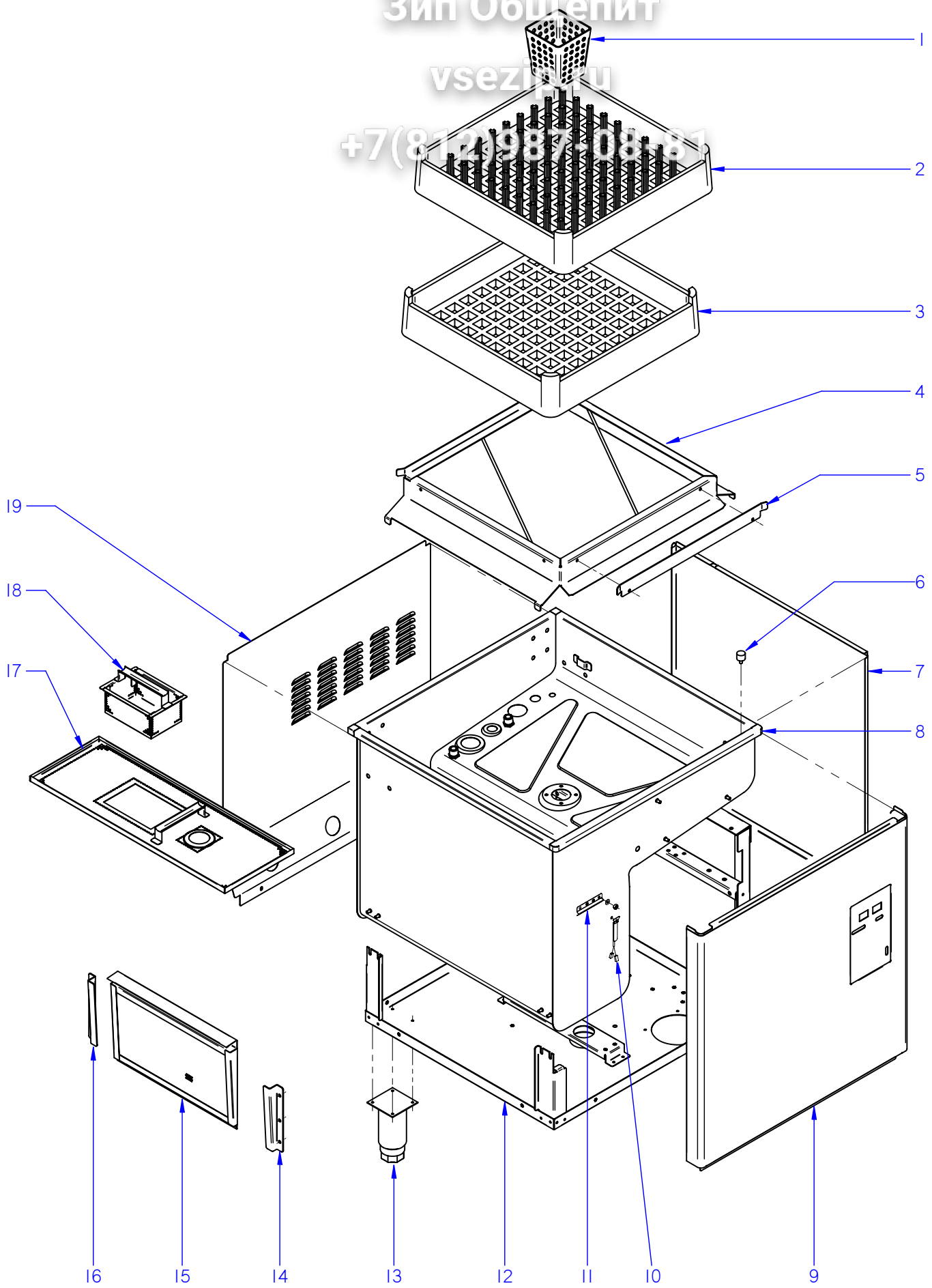

ITEM MARCADO EN COLOR = REPUESTO RECOMENDADO
COLOURED ITEM = RECOMMENDED SPARE PART

N plano	Firma	Fecha	Aparato	MUEBLE	Lamina	Fagor Industrial S.Coop. FAGOR
C-2493	<i>(Signature)</i>	2009-12	LAVAVAJILLAS AD-90		1	Oñate

MOD.	LAVAVAJILLAS DE CAPOTA	ZONA	MUEBLE
-------------	-------------------------------	-------------	---------------

ITEM	CODIGO	DENOMINACION	TEXTO	AD-90			
1	Z655314000	CESTILLO CUBIERTOS	CUTLERY BASKET	2			
2	Z655302000	CESTILLO PLATOS CP-16-18	PLATE BASKET CP-16-18	1			
3	Z655301000	CESTILLO BASE CT-10	BASE BASKET CT-10	1			
4	Z710377000	BASE CESTILLO COMPLETA	COMPLETE BASKET BASE	1			
5	Z710326000	GUIA CESTILLO	BASKET GUIDE	1			
	Q152004000	TORNILLO APLAST. M5x13 A304	MUSHROOM HEAD BOLT M5x13	2			
	Q242030000	ARANDELA ABANICO A5 A.304	FAN WASHER A5 A.304	2			
	Q162030000	TUERCA EXAGONAL M5	HEXAGONAL NUT M5	2			
	Q308000000	ARANDELA DUBO A.8	DUBO A.8 WASHER	14			
6	Z710316000	AMORTIGUADOR	DAMPER	2			
	Q262040000	ARANDELA GROW. A6 A.304	WASHER GROW. A6 A.304	2			
	Q162040000	TUERCA EXAGONAL M6	HEXAGONAL NUT M6	2			
	Q012073000	TORNILLO EXAGONAL M12x20	HEXAGONAL BOLT M12x20	1			
	Q306024000	JUNTA 18x12.2x1.5	SEAL 18x12.2x1.5	1			
	Q162070000	TUERCA EXAGONAL M12	HEXAGONAL NUT M12	1			
7	Z749311000	PANEL LATERAL DERECHO	RIGHT SIDE PANEL	1			
	Q152004000	TORNILLO APLAST. M5x13 A304	MUSHROOM HEAD BOLT M5x13	2			
S/Nº	Z749312000	PANEL LATERAL IZQUIERDO	LEFT SIDE PANEL	1			
	Q152004000	TORNILLO APLAST. M5x13 A304	MUSHROOM HEAD BOLT M5x13	2			
8	Z710379000	CUBA COMPLETA AD-80	COMPLETE TUB AD-80	1			
	Q232040000	ARANDELA A6	WASHER A6	4			
	Q302022000	ARANDELA 16x6x1.2 A.304	WASHER 16X6X1.2 A.304	4			
	Q262040000	ARANDELA GROW. A6 A.304	WASHER GROW. A6 A.304	8			
	Q162040000	TUERCA EXAGONAL M6	HEXAGONAL NUT M6	8			
9	Z712937000	PANEL FRONTAL AD-80-100-120	FRONT PANEL AD-80-100-120	1			
10	Z713028000	SONDAS TEMPERATURA GICAR	GICAR TEMPERATURE GAUGE	1			
S/Nº	Z718004000	AMARRE SONDA	PROBE FASTENING	1			
	Q242020000	ARANDELA ABANICO A.4 A304	FAN WASHER A.4 A304	1			
	Q162020000	TUERCA EXAGONAL M4	HEXAGONAL NUT M4	1			

Зип Общепит

vsezip.ru

+7(812)987-08-81

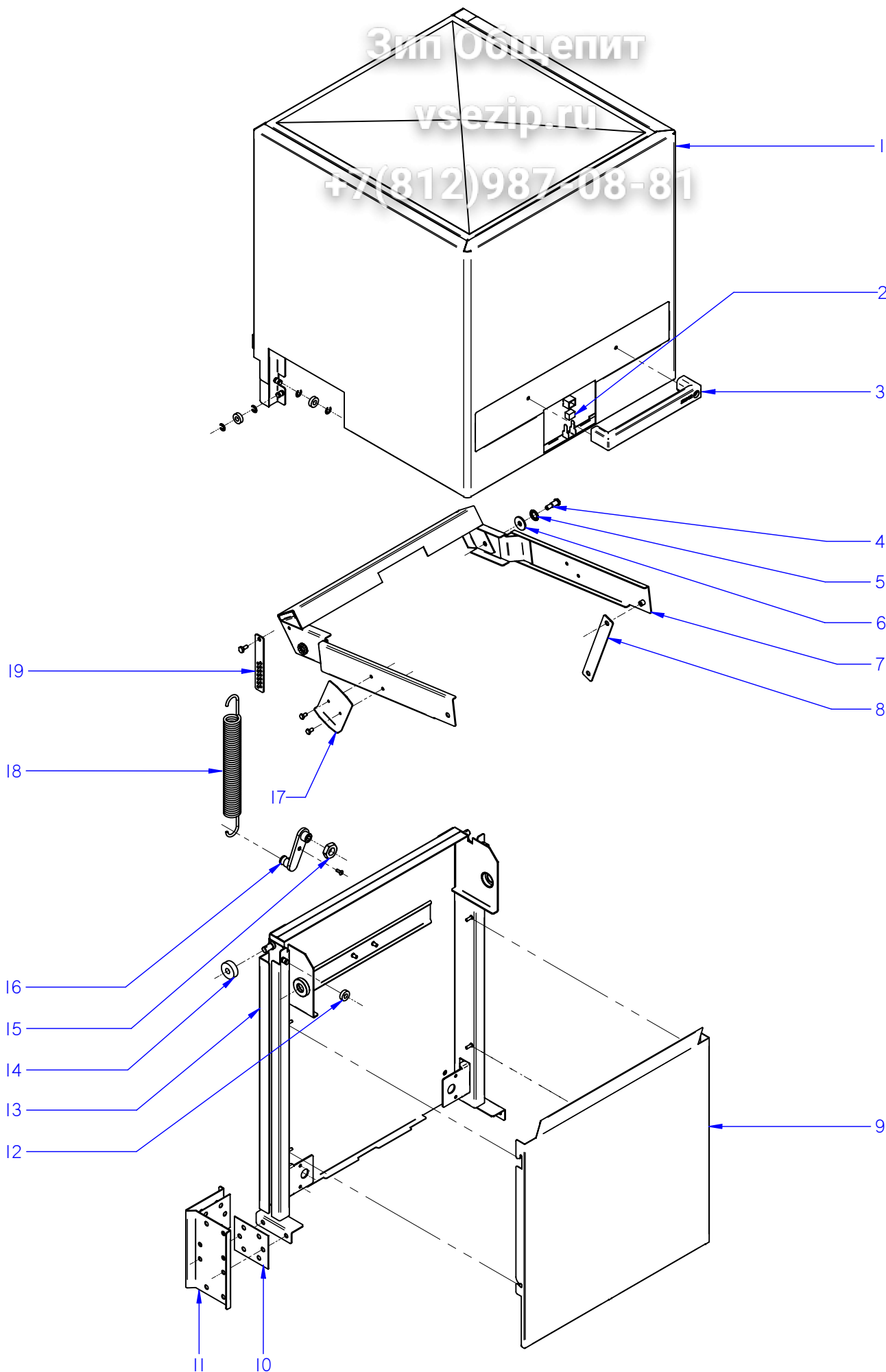

ITEM MARCADO EN COLOR = REPUESTO RECOMENDADO
COLOURED ITEM = RECOMMENDED SPARE PART

N plano	Firma	Fecha	Aparato	CAPO	Lamina	Fagor Industrial S.Coop. FAGOR
C-2494	<i>(Signature)</i>	2009-12	LAVAVAJILLAS AD-90		2	Oñate

MOD.		LAVAVAJILLAS DE CAPOTA	ZONA	CAPO			
ITEM	CODIGO	DENOMINACION	TEXTO	AD-90			
1	Z740505000	CAPO RECTO COMPLETO	COMPLETE STRAIGHT HOOD	1			
	Z710515000	CASQUILLO RODANTE	REVOLVING BUSHING	4			
	Q271006000	ARANDELA DE SEGURIDAD 8	SAFETY WASHER 8	8			
2	Z200506000	IMAN	MAGNET	1			
S/Nº	Z200507000	PROTECTOR IMAN	MAGNET PROTECTOR	1			
3	Z710558000	ASA CAPOTA AD	AD HOOD HANDLE	1			
	Q032041000	TORNILLO ALOMADO M6x10	CURVED SCREW M6x10	2			
	Q308002000	ARANDELA DUBO A6 NYLON	WASHER DUBO A6 NYLON	2			
4	Z710542000	EJE DE GIRO	ROTARY SHAFT	2			
5	Z710541000	RODAMIENTO 6200-2RS1	BEARING 6200-2RS1	2			
6	Q308012000	ARANDELA 30x10x3	WASHER 30x10x3	2			
7	Z710517000	BALANCIN COMPLETO	COMPLETE ROCKER ARM	1			
	Q232050000	ARANDELA A8	WASHER A8	2			
	Q262050000	ARANDELA GROW. A8 A.304	WASHER GROW. A8 A.304	2			
	Q162050000	TUERCA EXAGONAL M8x1 INOX.	HEXAGONAL NUT M8x1 INOX.	2			
8	Z710523000	BIELA	ROD	2			
	Q308012000	ARANDELA 30x10x3	WASHER 30x10x3	8			
	Q232040000	ARANDELA A6	WASHER A6	4			
	Q262040000	ARANDELA GROW. A6 A.304	WASHER GROW. A6 A.304	4			
	Q012041000	TORNILLO EXAGON. M6x10 A.304	HEXAGONAL BOLT. M6x10 A.304	4			
9	Z718932000	CUBIERTA RESORTES CLINIC	SPRING COVER	1			
10	Z710547000	JUNTA SOPORTE CAPO	HOOD SUPPORT SEAL	4			
	Q012053000	TORNILLO EXAGON. M8x20 A.304	HEXAGONAL BOLT. M8x20 A.304	10			
	Q013153000	TORNILLO EX M-8x20 LATON GRO.	HEX BOLT M-8x20 CHR. BRASS	4			
	Q232050000	ARANDELA A8	WASHER A8	14			
	Q262050000	ARANDELA GROW. A8 A.304	WASHER GROW. A8 A.304	14			
	Q162050000	TUERCA EXAG. M8x1 INOX.	HEXAG. SCREW M8x1 STAINLES	10			
11	Z710539000	SOPORTE GUIA CAPO	HOOD GUIDE SUPPORT	2			
12	Z710515000	CASQUILLO RODANTE	REVOLVING BUSHING	2			
	Q271006000	ARANDELA DE SEGURIDAD 8	SAFETY WASHER 8	4			

MOD.	LAVAVAJILLAS DE CAPOTA	ZONA	CAPO
-------------	-------------------------------	-------------	-------------

ITEM	CODIGO	DENOMINACION	TEXTO	AD-90			
13	Z710524000	GUIA CAPO COMPLETA	COMPLETE HOOD GUIDE	1			
	Q352024000	PASADOR DE ALETA 4x25	WING PIN 4x25	2			
14	Z710546000	CASQUILLO	BUSHING	2			
15	Q222016000	TUERCA EXAGONAL M20	HEXAGONAL BOLT M20	2			
16	Z710529000	TENSOR MUELLE	TENSIONING SPRING	2			
	Q152004000	TORNILLO APLAST. M5x13 A 304	MUSHROOM HEAD BOLT M5x13	2			
17	Z710548000	ESCUADRA TOPE	BUFFER BRACKET	2			
	Q012041000	TORNILLO EXAGON. M6X10 A.304	HEXAGONAL BOLT. M6X10 A.304	4			
	Q242040000	ARANDELA ABANICO	FAN WASHER	4			
18	Z710528000	RESORTE 29230	SPRING 29230	2			
19	Z710543000	ENGANCHE MUELLE	SPRING HOOK	2			
	Z710544000	EJE ENGANCHE MUELLE	SPRING HOOK SHAFT	2			
	Q232040000	ARANDELA A6	WASHER A6	2			
	Q222012000	TUERCA AUTOB. M6	SELF-LOCK NUT M6	2			

31 32 33 34 35 36

3ип Общепит
 ysa@zip.ru
 +7(812)987-08-81

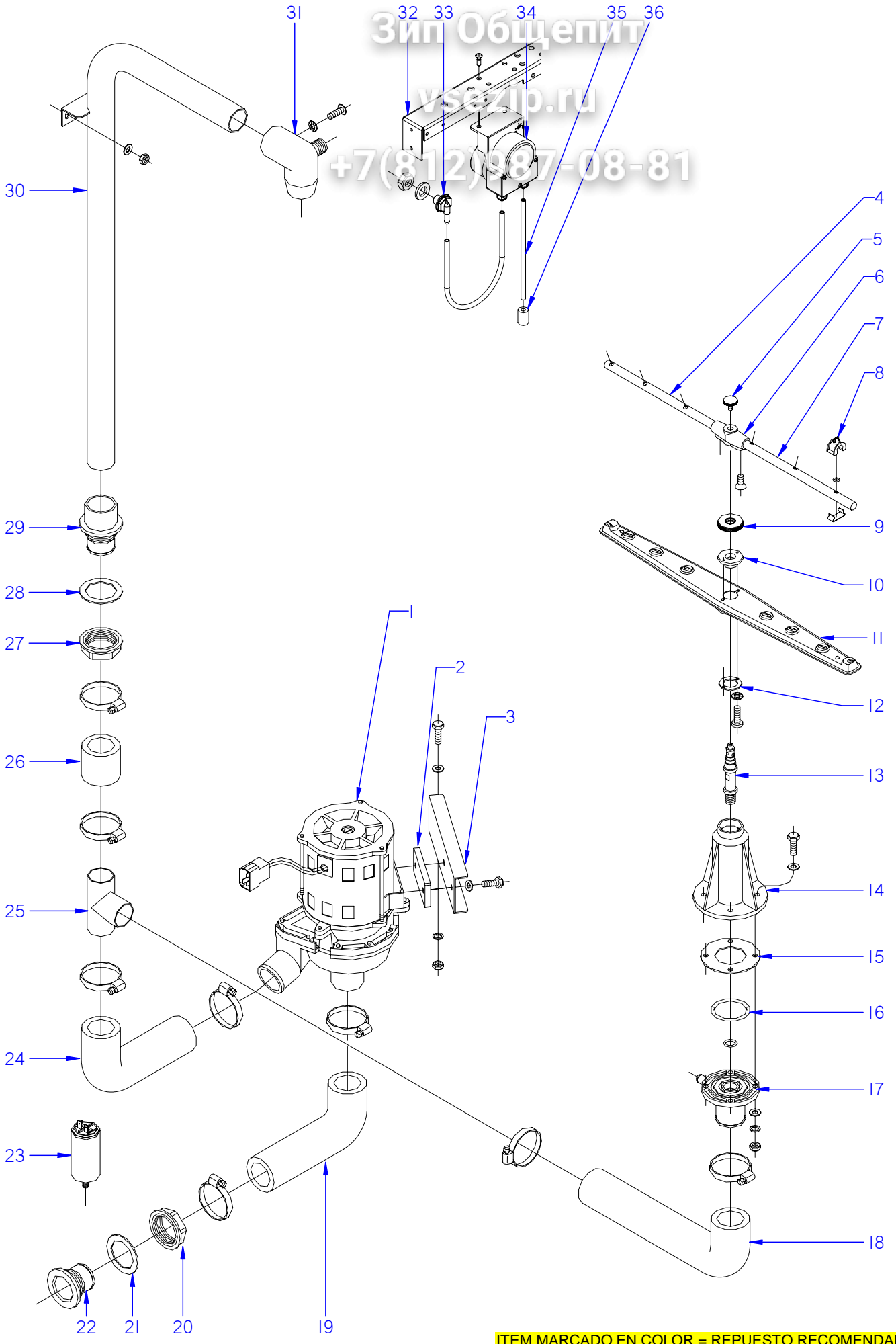

ITEM MARCADO EN COLOR = REPUESTO RECOMENDADO
 COLOURED ITEM = RECOMMENDED SPARE PART

N plano	Firma	Fecha	Aparato	CONJUNTO FUNCIONAL LAVADO	Lamina	Fagor Industrial S.Coop. FAGOR
C-2495	<i>[Signature]</i>	2009-12	LAVAVAJILLAS	AD-90	3	Oñate

MOD.	LAVAVAJILLAS DE CAPOTA	ZONA	CONJUNTO FUNCIONAL DE LAVADO
------	------------------------	------	------------------------------

ITEM	CODIGO	DENOMINACION	TEXTO	AD-90	AD-90 DD			
1	Z201011000	BOMBA DE LAVADO	WASH PUMP	1	1			
1	Z203511000	BOMBA DE LAVADO 60 HZ.	WASH PUMP 60 Hz.	1	1			
2	Z201003000	BASE BOMBA LAVADO 1003016	WASH PUMP BASE 1003016	1	1			
	Q232040000	ARANDELA A6	WASHER A6	2	2			
	Q012042000	TORNILLO EXAGONAL M6x15	HEXAGONAL BOLT M6x15	2	2			
3	Z711002000	SOPORTE MOTOBOMBA POSTER.	REAR MOTOR PUMP SUPPORT	1	1			
	Q012042000	TORNILLO EXAGONAL M6x15	HEXAGONAL BOLT M6x15	2	2			
	Q232040000	ARANDELA A6	WASHER A6	2	2			
	Q262040000	ARANDELA GROW. A6 A.304	WASHER GROW. A6 A.304	2	2			
	Q162040000	TUERCA EXAGONAL M6	HEXAGONAL NUT M6	2	2			
4	Z208712000	RAMA ACLARADO IZQUIERDA	LEFT RINSE BRANCH	2	2			
5	Q152016000	TORNILLO ESPECIAL M.5x0.8	SPECIAL BOLT M.5X0.8	2	2			
6	Z201903000	SOPORTE RAMA ACLARADO COM.	COM. RINSE BRANCH SUPPORT	2	2			
	Q042021000	TORNILLO AVELLAN. M4x10 A304	COUNTERSUNK BOLT M4x10 A304	4	4			
7	Z208713000	RAMA ACLARADO DERECHA	RIGHT RINSE BRANCH	2	2			
8	Z201905000	TOBERA ACLARADO	RINSE NOZZLE	12	12			
	Q307036000	JUNTA TORICA 5,25X8,84X1,78	O-RING 5,25X8,84X1,78	12	12			
	Z201906000	ENGANCHE TOBERA	ANCHORAGE NOZZLE	12	12			
9	Z200705000	TUERCA ESPECIAL	SPECIAL NUT	2	2			
10	Z650704000	ENGANCHE DISTRIBUIDOR	DISTRIBUTOR ANCHORAGE	2	2			
11	Z650716000	DISTRIBUIDOR COMPLETO	COMPLETE DISTRIBUTOR	2	2			
12	Z650711000	AMARRE ENGANCHE DISTRIBUID.	ANCHORAGE DISTRIBUTOR	2	2			
	Q032011000	TORNILLO ALOMADO M3x10	CURVED SCREW M3X10	4	4			
	Q242010000	ARANDELA ABANICO A3 A.304	FAN WASHER A3 A.304	4	4			
13	Z200704000	EJE CENTRAL	CENTRAL SHAFT	2	2			
14	Z740705000	SOPORTE DISTRIBUIDOR INFER.	LOWER DISTRIBUTION SUPPORT	1	1			
15	Z710714000	JUNTA DE GOMA	RUBBER SEAL	1	1			
16	Q307057000	JUNTA TORICA 47.22x54.28x3.53	O-RING 47.22x54.28x3.53	1	1			
	Q307050000	JUNTA TORICA 13.94x19.18x2.6	O-RING 13.94x19.18x2.6	1	1			

MOD.		LAVAVAJILLAS DE CAPOTA		ZONA		CONJUNTO FUNCIONAL DE LAVADO			
ITEM	CODIGO	DENOMINACION	TEXTO	AD-90	AD-90 DD				
17	Z710706000	PASAMUROS	BUSHING	1	1				
	Q012044000	TORNILLO EXAGONAL M6x25	HEXAGONAL BOLT M6x25	4	4				
	Q306050000	ARANDELA 6x12x1.5	WASHER 6x12x1.5	4	4				
	Q232040000	ARANDELA A6	WASHER A6	4	4				
	Q262040000	ARANDELA GROW. A6 A.304	WASHER GROW. A6 A.304	4	4				
	Q162040000	TUERCA EXAGONAL M6	HEXAGONAL NUT M6	4	4				
18	Z740903000	CONDUCTO INFERERIOR	LOWER PIPE	1	1				
19	Z710904000	CONDUCTO ASPIRACION	EXTRACTOR PIPE	1	1				
	Q881307000	ABRAZADERA 40-60	CLAMP 40-60	4	4				
20	Z710708000	TUERCA PASAMUROS	WALL BUSHING NUT	1	1				
21	Q307058000	ARANDELA 60x44x2	WASHER 60x44x2	1	1				
22	Z710903000	PASAMUROS ASPIRACION	EXTRACTOR BUSHING	1	1				
23	V321300000	CONDENSADOR 10 M,F,	CONDENSER 10 M,F,	1	1				
	Q162050000	TUERCA EXAGONAL M8x1 INOX,	HEXAGONAL NUT M8x1 INOX.	2	2				
24	Z740901000	CONDUCTO IMPULSION	IMPULSE PIPE	1	1				
	Q881307000	ABRAZADERA 40-60	CLAMP 40-60	2	2				
25	Z740905000	TE IMPULSION	IMPULSE T	1	1				
26	Z740902000	CONDUCTO SUPERIOR	UPPER PIPE	1	1				
	Q881307000	ABRAZADERA 40-60	CLAMP 40-60	2	2				
27	Z710708000	TUERCA PASAMUROS	WALL BUSHING NUT	1	1				
28	Q307058000	ARANDELA 60x44x2	WASHER 60x44x2	1	1				
29	Z740701000	PASAMUROS ARBOL LAVADO	WASH CAM BUSHING	1	1				
30	Z710709000	ARBOL LAVADO COMPLETO	COMPLETE WASH CAM	1	1				
	Q232040000	ARANDELA A6	WASHER A6	2	2				
	Q162040000	TUERCA EXAGONAL M6	HEXAGONAL NUT M6	2	2				
31	Z740703000	SOPORTE DISTRIBUIDOR SUPER.	UPPER DISTRIBUTION SUPPORT	1	1				
	Q152004000	TORNILLO APLAST. M5x13 A.304	MUSHROOM HEAD BOLT M5x13 A	1	1				
	Q242030000	ARANDELA ABANICO A5 A.304	FAN WASHER A5 A.304	1	1				
32	-----	TRAVESAÑO		-	1				
33	Z230905000	PASAMUROS DETERGENTE	INOX DETERGENT WALL BUSHING	-	1				
S/Nº	3699300000	CONDUCTO DOSIFICAFOR TRANS.	DOSEFOR CONDUIT	-	1				

MOD. **LAVAVAJILLAS DE CAPOTA** ZONA **CONJUNTO FUNCIONAL DE LAVADO**

ITEM	CODIGO	DENOMINACION	TEXTO	AD-90	AD-90 DD			
34	Z208903000	DOSIFIC. DGTE REGULABLE G300	DOSEFOR DETERGENT	-	1			
35	Z448614000	CONDUCTO ASPIRACIÓN	CONDUIT	-	1			
36	Z701152000	PESO FILTRO		-	1			

Зип Общежит

vsezip.ru

+7(812)987-08-81

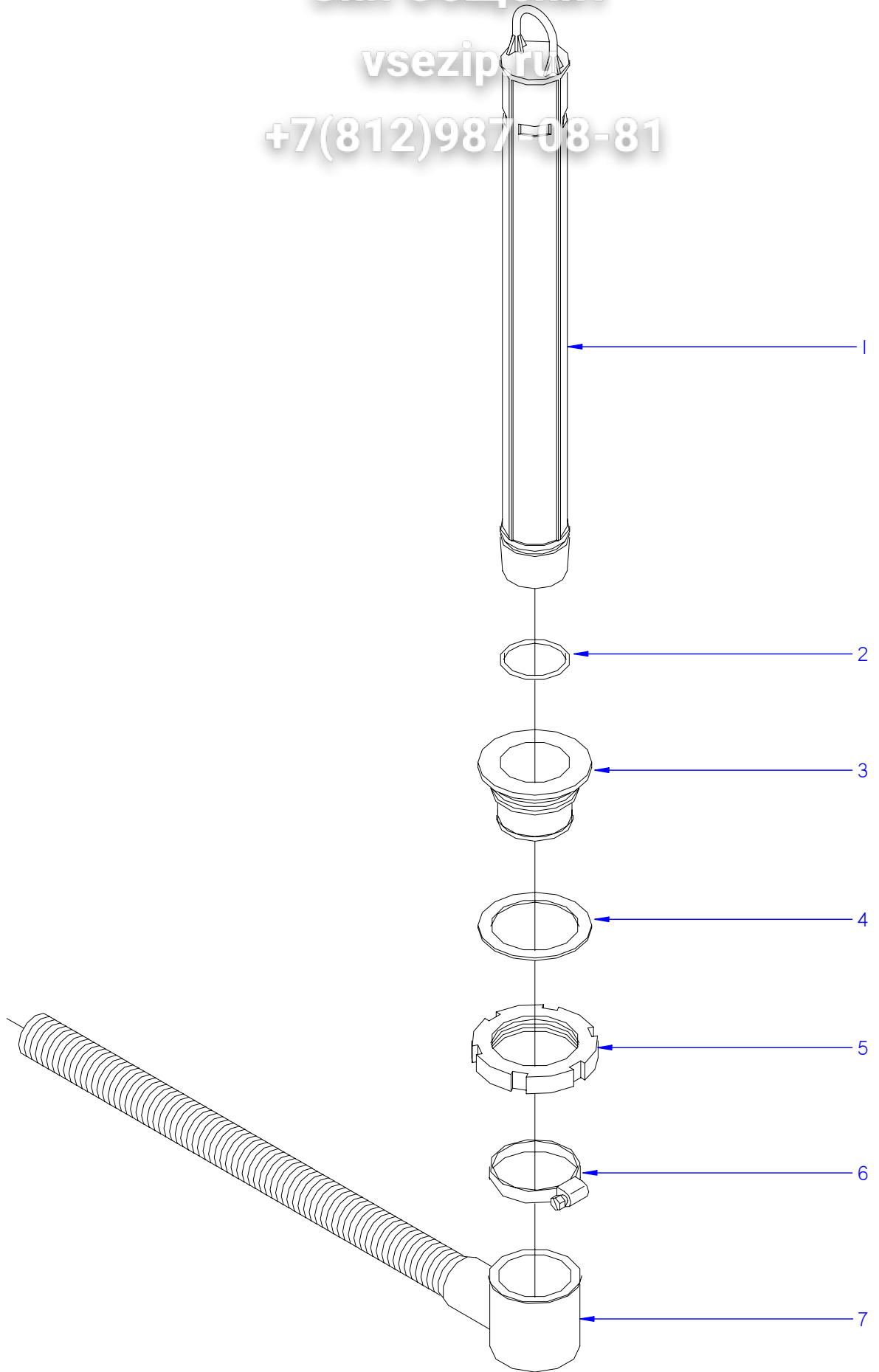

ITEM MARCADO EN COLOR = REPUESTO RECOMENDADO
COLOURED ITEM = RECOMMENDED SPARE PART

N plano	Firma	Fecha	Aparato	CONJUNTO FUNCIONAL DESAGUE	Lamina	Fagor Industrial S.Coop. FAGOR
C-2496	<i>(Signature)</i>	2009-12	LAVAVAJILLAS AD-90		4	Oñate

MOD.	LAVAVAJILLAS DE CAPOTA			ZONA		CONJUNTO FUNCIONAL DESAGÜE				
ITEM	CODIGO	DENOMINACION	TEXTO	AD-90						
1	Z710901000	ALIVIADERO	OVERFLOW	1						
2	Q307051000	JUNTA TOR.36.17X41.41X2.6	O-RING 36.17X41.41X2.6	1						
3	Z710902000	PASAMUROS DESAGUE	DRAINAGE BUSHING	1						
4	Q307059000	JUNTA 72x56x2	SEAL 72x56x2	1						
5	Q220001000	TUERCA RANURADA	GROOVED NUT	1						
6	Q881307000	ABRAZADERA 40-60	CLAMP 40-60	1						
7	Z200910000	MANGUERA DESAGUE	DRAINAGE HOSE	1						

Зип Общепит

vsezip.ru

+7(812)987-08-81

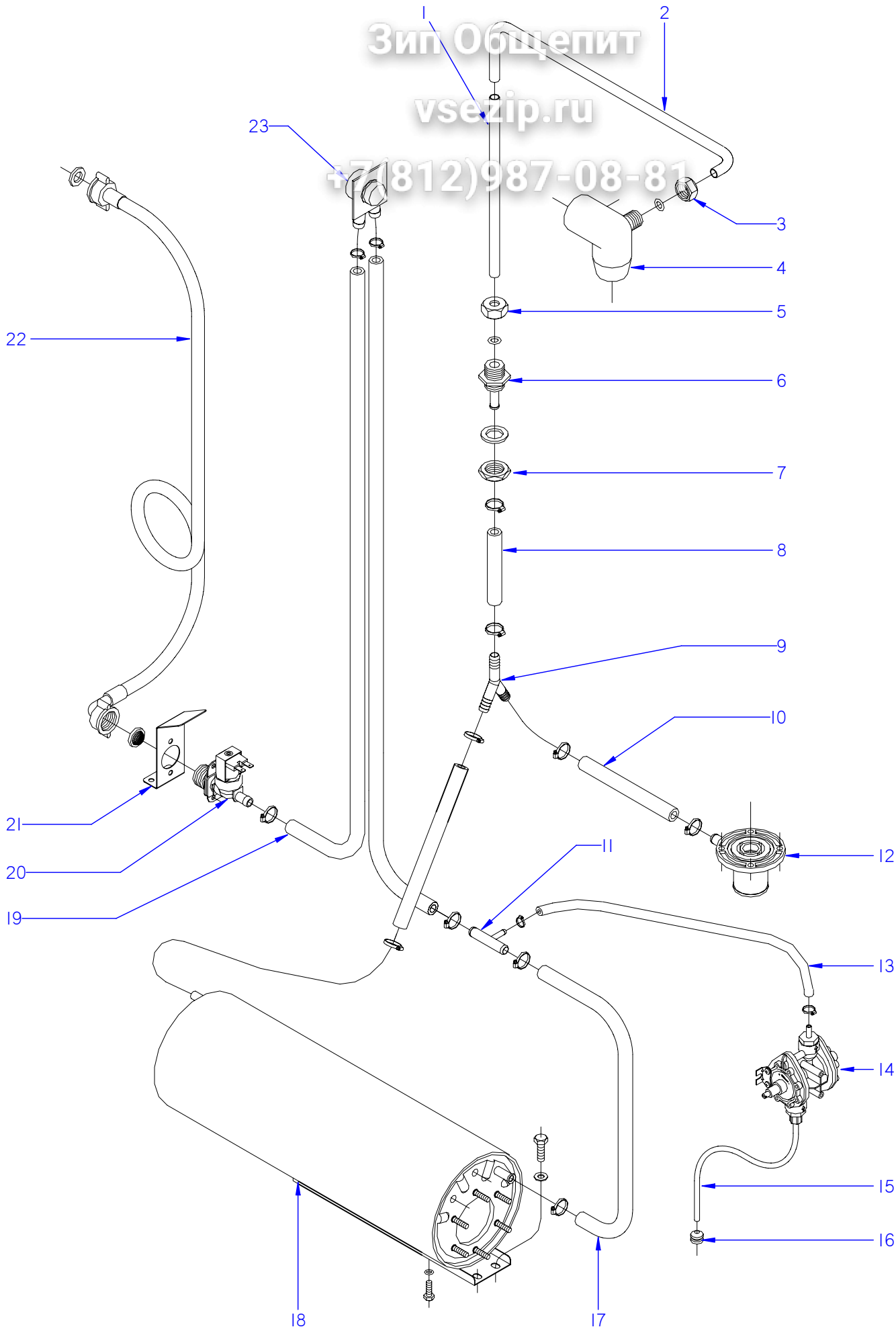

ITEM MARCADO EN COLOR = REPUESTO RECOMENDADO
COLOURED ITEM = RECOMMENDED SPARE PART

N plano	Firma	Fecha	Aparato	CONJUNTO FUNCIONAL ACLARADO	Lamina	Fagor Industrial S.Coop. FAGOR
C-2497	<i>[Signature]</i>	2009-12	LAVAVAJILLAS AD-90		5	Oñate

MOD.	LAVAVAJILLAS DE CAPOTA	ZONA	CONJUNTO FUNCIONAL ACLARADO
-------------	-------------------------------	-------------	------------------------------------

ITEM	CODIGO	DENOMINACION	TEXTO	AD-90			
1	Z711114000	TUBO EMPALME	CONNECTION PIPE	2			
2	Z711903000	CONDUCCION ACLARADO COMP.	COMP. RINSE PIPE	1			
3	Q223107000	TUERCA M.20x2.5	NUT M.20X2.5	1			
	Q307048000	JUNTA TORICA Ø9.12X16.18X3.53	O-RING Ø9.12X16.18X3.53	1			
4	Z740703000	SOPORTE DISTRIBUIDOR SUPER.	UPPER DISTRIBUTION SUPPORT	1			
	Q152004000	TORNILLO APLAST. M5x13 A.304	MUSHROOM HEAD BOLT M5x13	1			
	Q242030000	ARANDELA ABANICO A5 A.304	FAN WASHER A5 A.304	1			
5	Q223107000	TUERCA M.20x2.5	NUT M.20X2.5	1			
	Q307048000	JUNTA TORICA Ø9.12X16.18X3.53	O-RING Ø9.12X16.18X3.53	1			
6	Z711904000	PASAMUROS ACLARADO	RINSE BUSHING	1			
	Q307032000	JUNTA Ø 32X21X3	SEAL Ø 32X21X3	1			
7	Q223023000	TUERCA EXAGONAL 5-8 LATON	HEX NUT 5-8 BRASS	2			
8	3676900000	TUBO GOMA NEGRA Ø 17*10	BLACK RUBBER PIPE 17*10	1			
	Q881302000	ABRAZADERA 12-20	CLAMP 12-20	2			
9	Z201106000	RACORD EN Y	Y-CONNECTION	1			
10	3676900000	TUBO GOMA NEGRA Ø 17*10	BLACK RUBBER PIPE 17*10	2			
	Q881302000	ABRAZADERA 12-20	CLAMP 12-20	4			
11	Z601157000	TOMA PRESION	PRESSURE INTAKE	1			
12	Z710706000	PASAMUROS	BUSHING	1			
	Q012044000	TORNILLO EXAGONAL M6x25	HEXAGONAL BOLT M6x25	4			
	Q306050000	ARANDELA 6x12x1.5	WASHER 6x12x1.5	4			
	Q232040000	ARANDELA A6	WASHER A6	4			
	Q262040000	ARANDELA GROW. A6 A.304	WASHER GROW. A6 A.304	4			
	Q162040000	TUERCA EXAGONAL M6	HEXAGONAL NUT M6	4			
13	3704000000	TUBO GOMA NEGRO D 10,5*5	BLACK RUBBER PIPE Ø 10.5*5	1			
	Q881308000	ABRAZADERA 8-14L	CLAMP 8-14L	2			
14	Z211109000	DOSIFICADOR TENSOACTIVO N-6	SURFACE ACT. DISP. N-6	1			
	Q232030000	ARANDELA A5	WASHER A5	2			
	Q012031000	TORNIL. EXAGONAL M5x10 A.304	HEXAGONAL BOLT M5X10 A.304	4			
	Q163020000	TUERCA EXAGONAL M4 LATON	HEXAGONAL NUT M4 BRASS	2			
15	Z448618000	CONDUCTO ABRILLANTADOR	RINSE AID PIPE	1			

MOD.	LAVAVAJILLAS DE CAPOTA	ZONA	CONJUNTO FUNCIONAL ACLARADO					
ITEM	CODIGO	DENOMINACION	TEXTO	AD-90				
16	Z701152000	PESO FILTRO	FILTER WEIGHT	1				
17	3676900000	TUBO GOMA NEGRA Ø 17*10	BLACK RUBBER PIPE 17*10	1				
	Q881302000	ABRAZADERA 12-20	CLAMP 12-20	2				
18	Z201710000	CALDERIN COMPLETO	COMPLETE DRUM	1				
	Q012031000	TORNIL. EXAGONAL M5x10 A.304	HEXAGONAL BOLT M5X10 A.304	2				
	Q232030000	ARANDELA A5	WASHER A5	2				
	Q012063000	TORNIL. EXAGONAL M10x20 A.304	HEXAGONAL BOLT M10X20 A.304	1				
	Q307048000	JUNTA TORICA Ø9.12X16.18X3.53	O-RING Ø9.12X16.18X3.53	1				
19	3676900000	TUBO GOMA NEGRA Ø 17*10	BLACK RUBBER PIPE 17*10	2				
	Q881302000	ABRAZADERA 12-20	CLAMP 12-20	4				
20	Z701135000	ELECTR. SIMP.220V COD.255.208	SOLENOID VALVE SIMP.220V CO	1				
21	Z201101000	ESCUADRA AMARRE ELECTROVA	SOLENOID VALVE BRACKET	1				
	Q152024000	TORN. AVELLANADO M4x8 A.304	HEXAGONAL COUNTERSUNK M4	2				
	Q242020000	ARANDELA ABANICO A4 A.304	FAN WASHER A4 A.304	2				
	Q012031000	TORNIL. EXAGONAL M5x10 A.304	HEXAGONAL BOLT M5X10 A.304	2				
	Q232030000	ARANDELA A5	WASHER A5	2				
22	Z602121000	MANGUERA ENTRADA AGUA	WATER INTAKE HOSE	1				
23	Z231106000	VALVULA ANTIRRETORNO	NON-RETURN VALVE	1				
	Q881302000	ABRAZADERA 12/20	CLAMP 12/20	2				
S/Nº	Z711113000	SOPORTE VALVULA A.R.	VALVE SUPPORT A.R.	1				

Зип Общепит

vsezip.ru

+7(812)987-08-81

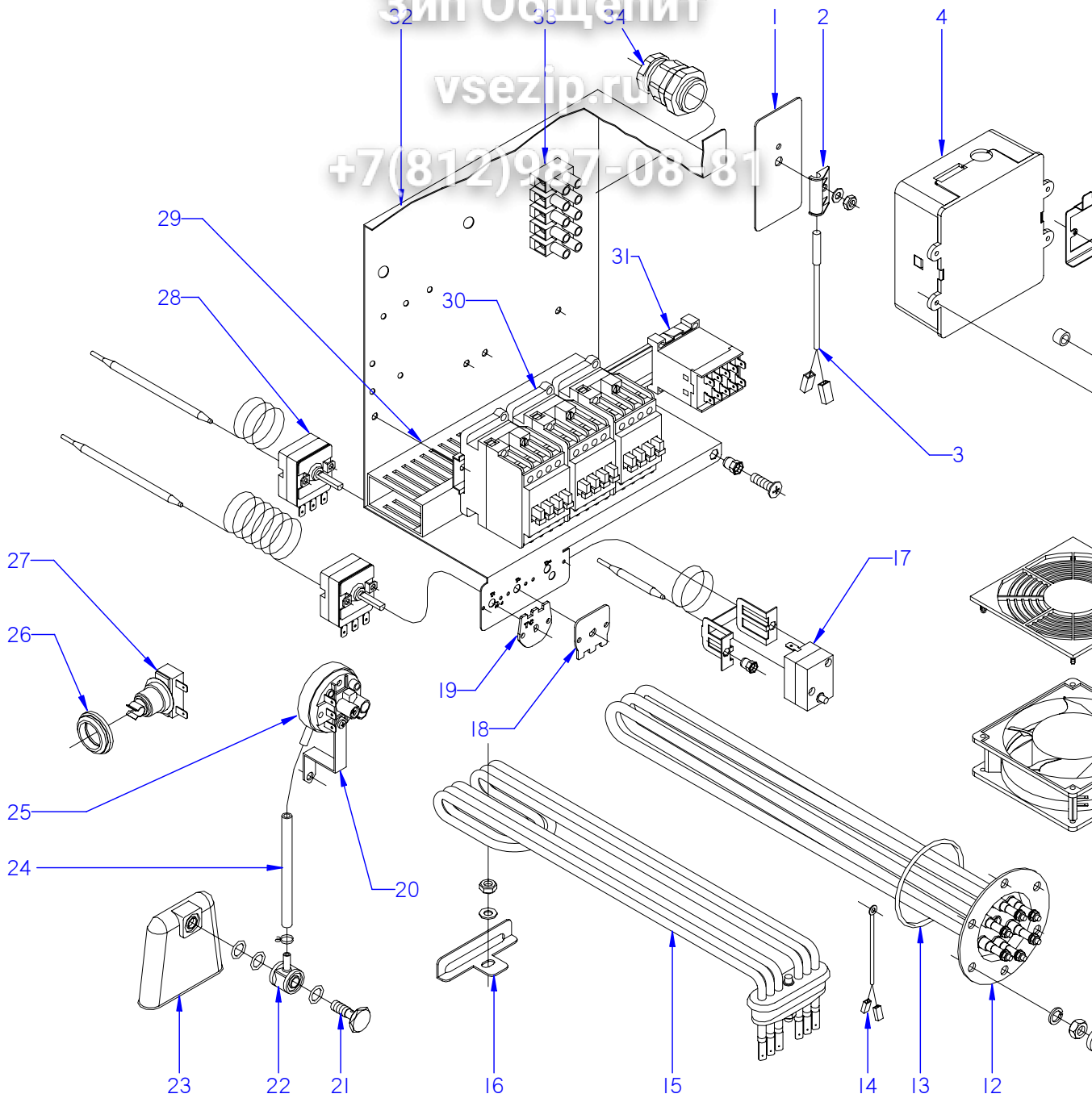

ITEM MARCADO EN COLOR = REPUESTO RECOMENDADO
COLOURED ITEM = RECOMMENDED SPARE PART

N plano	C-2498
Firma	
Fecha	2009-12
Aparato	CONJUNTO FUNCIONAL ELECTRICO LAVAVAJILLAS AD-90
Lamina	6
Order	Fagor Industrial S. Coop.

MOD.	LAVAVAJILLAS DE CAPOTA	ZONA	CONJUNTO FUNCIONAL ELECTRICA
------	------------------------	------	------------------------------

ITEM	CODIGO	DENOMINACION	TEXTO	AD-90				
1	Z101211000	APOYO INTERRUPTOR	SWITCH SUPPORT	1				
2	Z203010000	AMARRE INTERRUPTOR MAGNET.	MAGNETIC SWITCH FASTENER	1				
	Q232040000	ARANDELA A-6	WASHER A-6	1				
	Q162040000	TUERCA EXAGONAL M-6	HEXAGONAL NUT M-6	1				
3	Z203009000	INTERRUPTOR MAGNETICO	MAGNETIC SWITCH	1				
4	Z213069000	TARJETA 5 RELES	5 RELAY CARD	1				
	Q232020000	ARANDELA A4	WASHER A4	4				
	Q242020000	ARANDELA ABANICO A5 A.304	FAN WASHER A5 A.304	4				
	Q042022000	TORN. AVELLANADO M4X15	HEXAGONAL COUNTERSUNK M4	4				
	Z515045000	CASQUILLO SEPARADOR B	SEPARATOR BUSHING B	4				
5	Z713023000	SOPORTE DISPLAY CAPOTA	HOOD DISPLAY SUPPORT	1				
	R663036000	FIJACION CIRCUITO	CIRCUIT ATTACHMENT	3				
6	Z713017000	DISPLAY GICAR TEMPERATURAS	GICAR TEMPERATURE DISPLAY	1				
7	Z713027000	SOPORTE PROGRAMADOR RELÉ	RELAY PROGRAMMER SUPPORT	1				
	Q162030000	TUERCA EXAGONAL M5	HEXAGONAL NUT M5	2				
	Q262030000	ARANDELA GROW. A5 A.304	WASHER GROW. A5 A.304	2				
8	Z742916000	EMBELLECEDOR ADHESIVO AD-90	ADHESIVE TRIM AD-90	1				
	Q152004000	TORNILL, APLASTADO M5x13 A304	FLAT HEADED BOLT M5x13 A304	2				
9	Z713015000	PROTECCION VENTILADOR ABS	FAN PROTECTION ABS	1				
	Q042022000	TORNILLO AVELLANADO M4x15	COUNTERSUNK BOLT M4x15	8				
	Q162020000	TUERCA EXAGONAL M4	HEXAGONAL NUT M4	12				
	Q242020000	ARANDELA ABANICO A-4 A304	FAN WASHER A-4 A304	8				
10	Z103066000	VENTILADOR 230V,50/60 HZ	FAN 230V,50/60 HZ	1				
11	Z651731000	CAPERUZA RESISTEN. CALDERIN	DRUM RESIST. CAP	1				
	Q163140000	TUERCA EXAGONAL M6 LATON	HEXAGONAL NUT M6 BRASS	2				
	Q012031000	TORNIL. EXAGONAL M5x10 A.304	HEXAGONAL BOLT M5X10 A.304	2				
	Q232030000	ARANDELA A-5	WASHER A-5	2				
12	Z241701000	RESISTENCIA CALDERIN	DRUM RESISTOR	1				
	Q221305000	TUERCA EX, AUTO. M4 ZINCADA	HEX NUT , AUTO. M4 ZINC-COAT	6				
	Q163140000	TUERCA EXAGONAL M6 LATON	HEXAGONAL NUT M6 BRASS	6				
	Q262040000	ARANDELA GROW. A6 A,304	WASHER GROW. A6 A.304	6				

MOD.	LAVAVAJILLAS DE CAPOTA	ZONA	CONJUNTO FUNCIONAL ELECTRICA
------	------------------------	------	------------------------------

ITEM	CODIGO	DENOMINACION	TEXTO	AD-90				
13	Q307035000	JUNTA TORICA AN-36 282333	O-RING AN-36 282333	1				
14	Z713028000	SONDAS TEMPERATURA GICAR	GICAR TEMPERATURE GAUGE	1				
15	Z743601000	RESISTENCIA TANQUE	TANK RESISTOR	1				
16	Z743602000	SOPORTE RESISTENCIA TANQUE	TANK RESISTOR SUPPORT	1				
	Q232040000	ARANDELA A,6	WASHER A,6	1				
	Q162040000	TUERCA EXAGONAL M6	HEXAGONAL NUT M6	1				
17	Z213014000	LIMITADOR TECASA P.	LIMITER TECASA P.	1				
S/Nº	Z203060000	AMARRE LIMITADOR TECASA	LIMITER FASTENING TECASA	1				
	Q221341000	REMACHE EXAGONAL M4	HEXAGONAL RIVET M4	2				
	Q152024000	TORNILLO AVELLANADO M4x8	COUNTERSUNK BOLT M4x8	2				
18	Z713038000	REGU. TERMOS. TANQUE 60 °C	TANK THERMOSTAT CONTROL 60	1				
19	Z718446000	CHAPA W 85°C	PLATE W 85°C	1				
20	Z602923000	SOPORTE PRESOSTATO	PRESSURE SWITCH SUPPORT	1				
	Q082032000	TORNILLO ALOMADO BZ-3,5x9,5	CURVED SCREW BZ-3.5x9.5	1				
	Q162040000	TUERCA EXAGONAL M6	HEXAGONAL NUT M6	1				
	Q232040000	ARANDELA A6	WASHER A6	1				
21	Z203013000	TORNILLO PRESOSTATO	PRESSURE SWITCH BOLT	1				
22	Z203012000	EMPALME PRESOSTATO	PRESSURE SWITCH CONNEX	1				
	Q307003000	JUNTA TOR.16,01x10,77x2,62	O-RING 16.01x10.77x2.62	3				
23	Z203011000	CAMARA PRESOSTATO	PRESSURE SWITCH	1				
24	3702400000	TUBO DE GOMA 8x4 D8*4	RUBBER PIPE 8x4 D8*4	1				
	P102154000	BRIDA ELASTICA TUBO	ELASTIC PIPE FLANGE	2				
25	Z713002000	PRESOSTATO SIMPLE	SIMPLE PRESSURE SWITCH	1				
26	N503017000	SOPORTE TERMOSTATO 1001713	THERMOSTAT SUPPORT 1001713	2				
S/Nº	P443060000	TAPON	COVER	1				
27	R213004000	TERMOSTATO REARME MANUAL	MANUAL RESET THERMOSTAT	1				
28	Z393005000	TERMOSTATO CALDERIN	WASH DRUM THERMOSTAT	2				
	Q152024000	TORNILLO AVELLANADO M4x8	COUNTERSUNK BOLT M4x8	2				

MOD.		LAVAVAJILLAS DE CAPOTA	ZONA	CONJUNTO FUNCIONAL ELECTRICA			
ITEM	CODIGO	DENOMINACION	TEXTO	AD-90			
29	3715520000	CANALETA UNEX 60,30,77	PIPING UNEX 60.30.77	3			
	Q419005000	REMACHE 4x8 ALMG3 / ALUMINIO	RIVET 4X8 ALMG3 / ALUMINIUM	2			
	Q221342000	REMACHE EXAGONAL M5	HEXAGONAL RIVET M5	1			
	Q232040000	ARANDELA A6	WASHER A6	2			
	Q162040000	TUERCA EXAGONAL M6	HEXAGONAL NUT M6	2			
	Q152004000	TORNILL, APLASTADO M5x13 A304	FLAT HEADED BOLT M5x13 A304	1			
	Z103064000	BASE UNEX 1252	BASE UNEX 1252	2			
S/Nº	Z403016000	GUIA CONTACTOR L-100	CONTACTOR GUIDE L-100	1			
	R663055000	GUIA CONTACTOR L-120	CONTACTOR GUIDE L-120	1			
30	Z203050000	CONTAC. SIRIUS 3R 230V.50-60	CONTACT. SIRIUS 3R 230V.50-60	3			
31	Z203062000	RELE 230V. 16A-60 HZ	RELAY 230V. 16A-60 HZ	1			
	Z103083000	GUIA CONTACTOR L-73	CONTACTOR GUIDE L-73	1			
32	Z713037000	CAJA CUADRO ELECTRICO	SWITCHBOARD BOX	1			
33	Z743006000	REGLETA DE CONEXIONES	CONNECTION STRIP	1			
	Q152004000	TORNILL, APLASTADO M5x13 A304	FLAT HEADED BOLT M5x13 A304	2			
	Q232030000	ARANDELA A5	WASHER A5	2			
	Q162030000	TUERCA EXAGONAL M5	HEXAGONAL NUT M5	2			
34	R023013000	PRENSA ESTOPAS	STUFFING BOX	1			

MOD.	LAVAVAJILLAS DE CAPOTA		ZONA	VARIOS				
ITEM	CODIGO	DENOMINACION	TEXTO	AD-90	AD-90 DD			
	Z716135000	FOLLETO DE INSTRUCCIONES AD	INSTRUCTION LEAFLET	1	1			
	Z713026000	ESQUEMA TEORICO AD	THEORETICAL DIAGRAM AD.	1	1			
	Z713025000	PLANO DE MONTAJE AD	ASSEMBLY PLAN AD	1	1			
	Z723012000	CABLEADO CALDERIN AD-120	DRUM AD-120 WIRING	1	1			
	Z713019000	CABLEADO PROLONGAD. SONDAS	PROBE WIRING	1	1			
	Z713021000	CABLE CONEXIÓN PLACA-DISPLAY	DISPLAY CONNECTI. WIRING	1	1			
	Z713040000	CABLEADO PROLONG. EMB.MEMB.	PROBE WIRING	1	1			
	Z713024000	INSTALACION ELECTRICA AD	ELEC. INSTALATION AD	1	1			
	Z718946000	CABLEADO TRIFASICO 10 MM.	III+N WIRING	1	1			
	Z208904000	CABLEADO DOSIFICADOR DTGTE	DOSEFOR DETERGEN. WIRING	1	1			

AD 120, AD 120 B, AD 120 B BT, AD 120 C, AD 120 HY, AD 120 W,
 AD 100, AD 100 B, AD 100 B BT, AD 100 C, AD 100 HY, AD 100 W,
 AD 90, AD 90 B, AD 90 B BT, AD 90 C, AD 90 HY, AD 90 W,

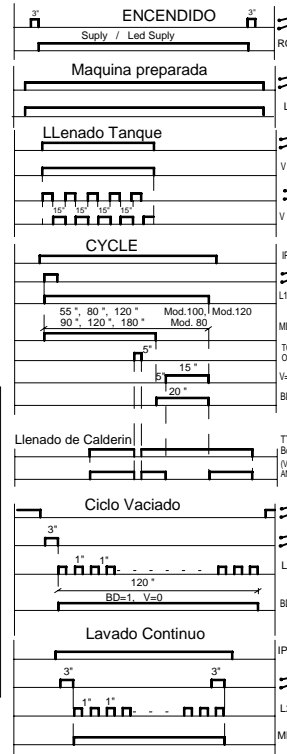
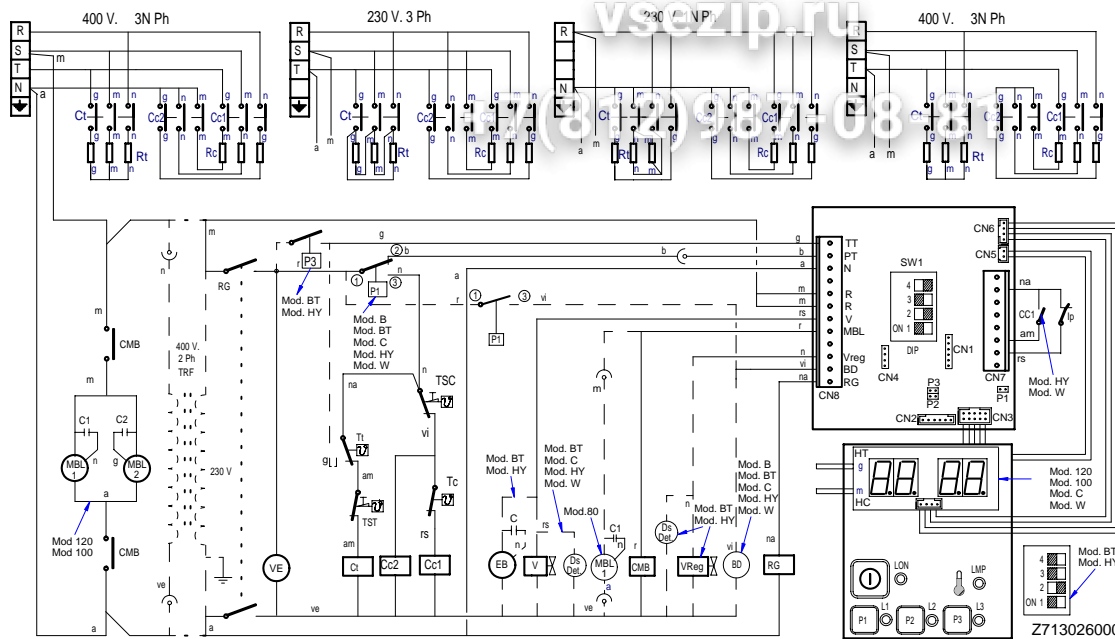

FAGOR ELECTRONICO MODELO ADVANCE	DIP1	DIP2	DIP3	DIP4	TIEMPOS CICLOS (sg.)
AD-90 , AD-90 DD, AD-90 B BT	ON	OFF	OFF	OFF	P1=75 / P2= 120 / P3=180
AD-90 W	ON	OFF	OFF	ON	
AD-120, AD-120 B, AD-120 B BT, ADE-120, ADE-120 B.	ON	OFF	ON	OFF	P1=55 / P2= 80 / P3=120 - ∞
AD-120 W, AD-120 HY , AD- 120 C	ON	OFF	ON	ON	

DIP1 = ON, al cerrar la puerta o bajar capó el lavavajillas se pone en marcha.
DIP1 = OFF, al cerrar la puerta o bajar el capo el lavavajillas sigue lavando **SÓLO SI EL CICLO NO HA ACABADO**.

DIP2 = ON, Para los modelos que llevan **DESCALCIFICADOR**, versiones "D".
DIP2 = OFF, para los modelos con **BOMBA DESAGÜE**, versiones "B".

DIP1 + DIP3, con las diferentes combinaciones posibles configuramos los tiempos de ciclo.

DIP4 = ON, **TERMOSTOP ACTIVADO**, para los modelos con termo stop, versiones "C", "W" y "HY".
DIP4 = OFF, **TERMOSTOP DESACTIVADO**, para los modelos que **NO** llevan **TERMOSTOP**.

Zk. No	Proiza	Sinadura/Firma	Data/Fe
Zk. No	Aidaketa/Modificaciones	M.Maillo	30-05-2
		M.Maillo	30-05-2
		Z. Alube	30-05-2

Plano hau ezin daiteke er

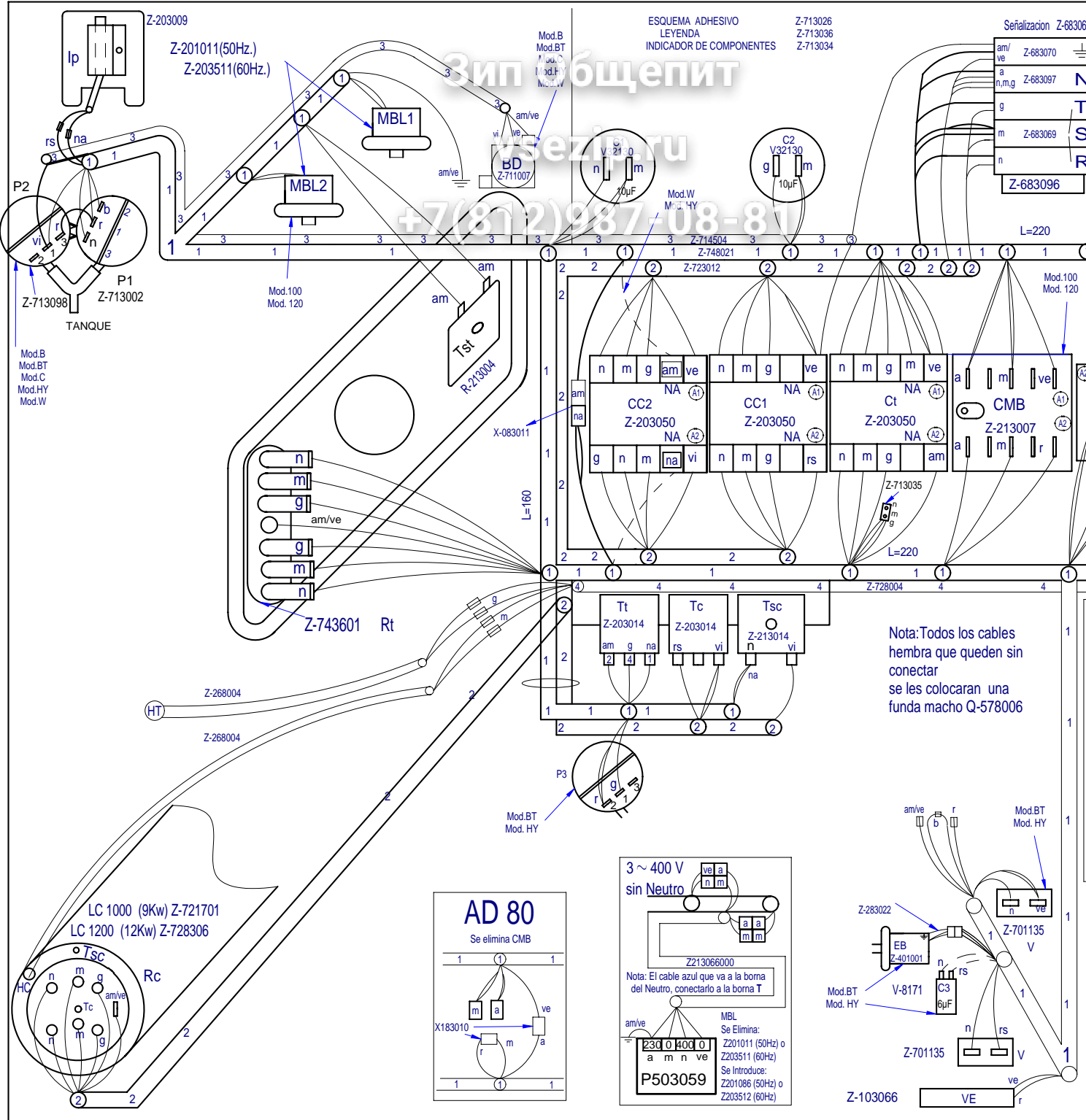

LEYENDA CAPOTA

	ESPAÑOL	FRANÇAIS	ENGLISH	DEUTSCH
Ⓐ Ⓑ	Puntos de conexión con R	Points de conexión R	Conecction point with R	Anschlußpunkte mit R
BD	Bomba desagüe	Pompe de vidange	Drain pump	Abflußpumpe
C 1/2/3	Condensador	Condensateur	Condenser	Kondensator
CMB	Contacto bomba lavado	Contacteur pompe lavage	Wash pump contactor	Kontaktschütz Waschpumpe
Cc 1/2	Contacto calentamiento calderin	Contacteur chauff. surchauffeur	Boiler heating contactor	Kontaktschütz Boilerheizung
Ct	Contacto calentamiento tanque	Contacteur chauffage cuve	Tank heating contactor	Kontaktschütz Heizung Tank
CP	Rele puerta	Relais porte	Door relay	Türrelais
Ds.Det.	Dosificador detergente	Dosueur de detergent	Detergent doser	Dosierer Spülmittel
E.B	Electrobomba de presión	Electropompe de pression	Electric pressure pump	Elektro-Drucksteigerungspumpe
IG	Interruptor general	Interrupteur general	Main switch	Hauptschalter
IP	Micro puerta	Micro porte	Door microswitch	Mikroschalter Tür
L1	Piloto de encendido	Voyant fonctionnement	Operation light	Betriebsanzeigelampe
L2	Piloto marcha	Voyant démarrage	Start light	Startanzeigelampe
L3	Piloto maquina preparada	Voyant machine prêt	Light machine ready	Betriebsbereitschaftsanzeige
MBL 1/2	Bomba lavado	Pompe lavage	Wash pump	Waschpumpe
M	Motor programador	Moteur du programmeur	Motor programmer	Motor Programmiervorrichtung
M Av. R	Motor program. avance rapido	Moteur du progr.avance rapide	Motor program. rapid advance	Motor Programmiervorrich. so
M1	Micro programador marcha	Micro du programm. de marche	Micro programmer on	Motor Programmiervorrich. B
M2	Micro programador lavado	Micro du programm. de lavage	Micro programmer wash	Motor Programmiervorrich. W
M3	Micro programador aclarado	Micro du programm. de rinçage	Micro programmer on	Motor Programmiervorrich. S
M4	Micro programador Termo-stop	Micro du programm. Termo-stop	Micro programmer Termo-stop	Motor Programmiervorrich. Th
M5	Micro programador avance	Micro du programm. avance	Micro programmer advance	Motor Programmiervorrich. V
M6	Micro programador avance	Micro du programm. avance	Micro programmer advance	Motor Programmiervorrich. V
P, P1, P5	Presostato	Pressostat	Pressure switch	Druckwächter
P2, P3, P4	Presostato limitador	Pressostat de sécurité	Hi-limit pressure switch	Begrenzer Druckwächter
R	Rele de Generador de A.C.	Relais du Generateur	Generator rele	Relais Generator
Ⓡ Ⓝ	Toma de alimentac. Generador A.C.	Alimentation generateur	Water heater feeding	Stromversorgungsanschluß C
RC	Resistencia calderin	Resistance surchauffeur	Boiler heating element	Heizwiderstand Boiler
RT	Resistencia tanque	Resistance cuve	Tank heater	Heizwiderstand Tank
Tt	Termostato tanque	Thermostat de cuve	Tank thermostat	Thermostat Tank
TC	Termostato calderin	Thermostat surchauffeur	Boiler thermostat	Thermostat kessel
Tst	Limitador tanque	Limiteur de cuve	Tank limiter	Begrenzer Tank
TSC	Limitador calderin	Limiteur surchauffeur	Boiler Hi-limit	Begrenzer Boiler
TSTP	Termostato termo-stop	Thermostat Termo-stop	Termo-stop Thermostat	Thermostat Termo-stop
V	Electrovalvula llenado y aclarado	Electrovan. remplissage rinçage	Fill and rinse valve	Elektroventil Füllen und Spül
VE	Ventilador cuadro electrico	Ventilateur tableau électrique	Switchboard fan	Schalttafelventilator
COLOR	COLORES	COULEURS	COLOUR	FARBEN
a =	Azul	Bleu	Blue	Blau
am =	Amarillo	Jaune	Yellow	Gelb
am/ve =	Amarillo/verde	Jaune / vert	Yellow / green	Gelb/grün
b =	Blanco	Blanc	White	Weiß
g =	Gris	Gris	Grey	Grau
m =	Marrón	Marron	Brown	Braun
n =	Negro	Noir	Black	Schwarz
na =	Naranja	Orange	Orange	Orange
r =	Rojo	Rouge	Red	Rot
rs =	Rosa	Rose	Pink	Rosa
ve =	Verde	Vert	Green	Grün
vi =	Violeta	Violet	Purple	Violett