

Зип Ощепит

vsezip.ru

DESPIECE TECNICO
LISTE DE PIÈCES DÉTACHÉES
SPARE PARTS LIST

Julio - 1997

LAVAVAJILLAS
LAVEVAISSELLES
DISH WASHING MACHINE

Modelos:
FI-30



Proyectos e Instalaciones y S.A.T.
Oñati, 26 de Agosto de 1997

Hostelería, Frío Comercial y Lavandería Industrial
Grandes Cuisines, Froid Commercial et Buanderie
Catering, Commercial Refrigeration and Laundry Equipment

Fagor Industrial, S. Coop.
20560 - Oñati - España

FAGOR



Зип Общепит

VSE ZP TU

81219870801

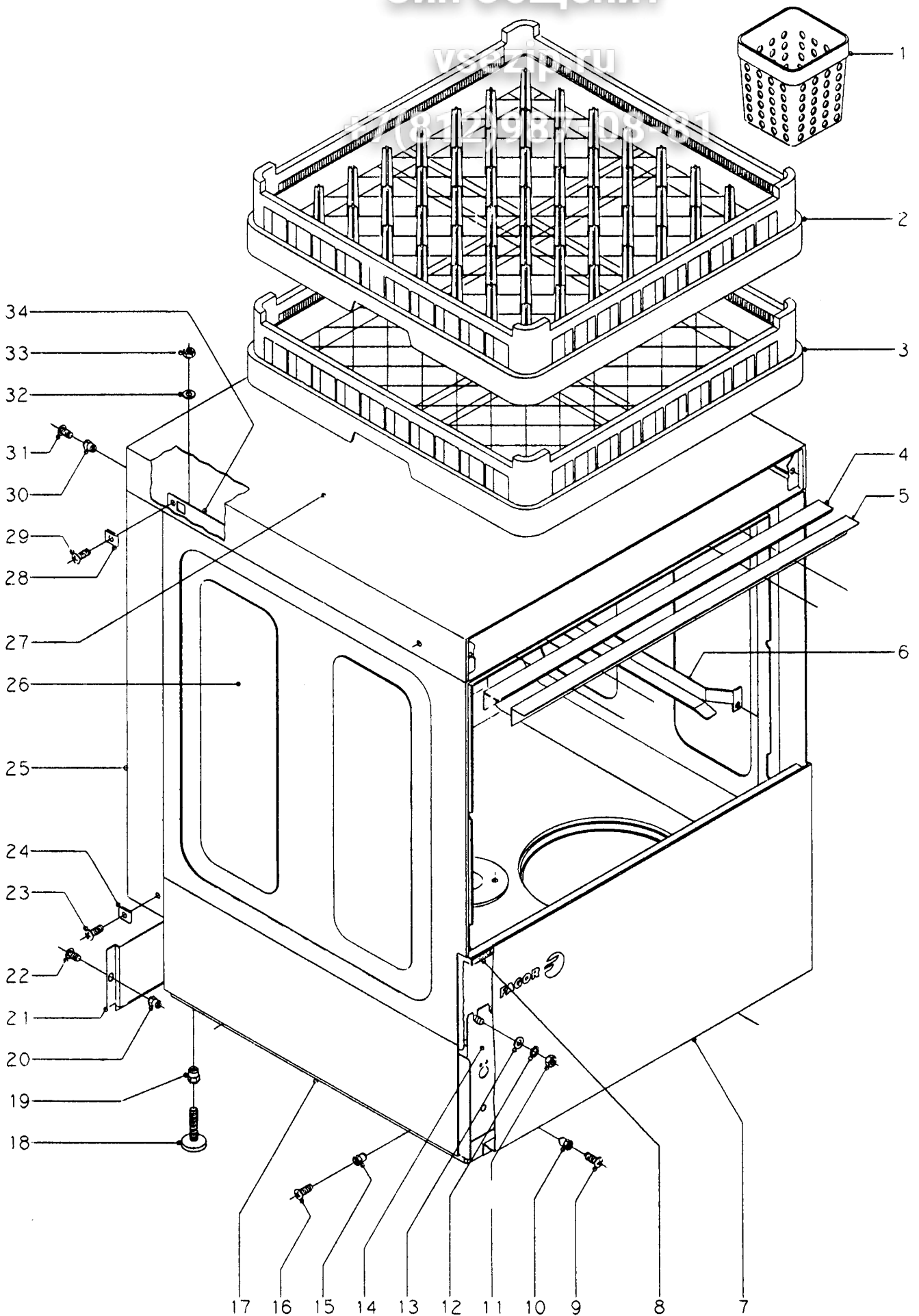

N plano
C-460

Firma
[Signature]

Fecha
7-97

Aparato

LAVAVAJILLAS FI-30

Lamina
1

Fagor Industrial S. Coop. **FAGOR**
Dibute

Зип Ощепит

vsezip.ru

+7(812)987-08-81

CONCEPTO: MUEBLE EXTERIOR
SUJET: MEUBLE EXTERIEUR
CONCEPT: EXTERNAL CABINET

LAMINAN°
VUE N°
ILUSTR. N.

1

APARATO - APPAREIL - APPLIANCE: LAVAVAJILLAS - LAVEVAISSELLES - DISH WASHING MACHINE

MODELO Y CANTIDAD - MOD. I

N°	CODIGO	DENOMINACION	DENOMINATION	DESCRIPTION	FI-30		
1	Z655314	Cestillo cubiertos	Panier	Basket	1		
2	Z655302	Cestillo platos CP-16/18	Panier	Basket	1		
3	Z655301	Cestillo base CT-10	Panier base CT - 10	Base basquet CT - 10	1		
4	Z200315	Perfil caja	Profil	Profile	1		
5	Z200309	Escuadra sujeción perfil	Equerre fixation profil	Fastening plate	1		
6	Z200305	Guía cestillo derecha	Guide panier droite	Right basket guide	1		
s/n	Z200306	Guía cestillo izquierda	Guide panier gauche	Left basket guide	1		
	Q232040	Arandela plana A.6	Rondelle A.6	Washer A.6	4		
	Q162040	Tuerca exagonal M.6	Ecrou M.6	Nut M.6	4		
7	Z202901	Panel frontal	Panneau frontal	Front panel	1		
8	Z200313	Perfil goma esponjosa	Profil mousseux	Spongy profile	1		
9	Q152004	Tornillo aplastado M.5x13	Vis M.5x13	Bolt M.5x13	2		
10	Q221342	Remache exagonal M.5	Rivet M.5	Rivet M.5	2		
11	Q162040	Tuerca exagonal M.6	Ecrou M.6	Nut M.6	8		
12	Q262040	Arandela muelle A.6	Rondelle A.6	Washer A.6	8		
13	Q232040	Arandela plana A.6	Rondelle A.6	Washer A.6	8		
14	Z200101	Armazón completo	Châssis	Complete frame	1		
15	Q221342	Remache exagonal M.5	Rivet M.5	Rivet M.5	4		
16	Q152004	Tornillo aplastado M.5x13	Vis M.5x13	Bolt M.5x13	4		
17	Z202903	Panel lateral izquierdo	Panneau lateral gauche	Side left panel	1		
s/n	Z202902	Panel lateral derecho	Panneau lateral droit	Side right panel	1		
18	Z200105	Pata regulable	Pied réglable	Adjustable leg	4		
19	Q221345	Remache exagonal M.10	Rivet M.10	Rivet M.10	4		
20	Q221342	Remache exagonal M.5	Rivet M.5	Rivet M.5	2		
21	Z202912	Panel posterior inferior	Panneau posterieur inferieur	Low rear panel	1		
22	Q152004	Tornillo aplastado M.5x13	Vis M.5x13	Bolt M 5.13	2		
23	Q152004	Tornillo aplastado M.5x13	Vis M.5x13	Bolt M.5x13	2		
24	Q221012	Tuerca rápida M.5	Ecrou M.5	Nut M.5	2		
25	Z202904	Panel posterior	Panneau posterieur	Rear panel	1		
26	Z200301	Caja soldada	Boîte complete	Compleat case	1		
27	Z202906	Tapa	Couvercle	Cover	1		

25 26 27 28 29 30 31 32 33 34 35

Зип Общепит

vsezip.ru

+7(812)987-08-81

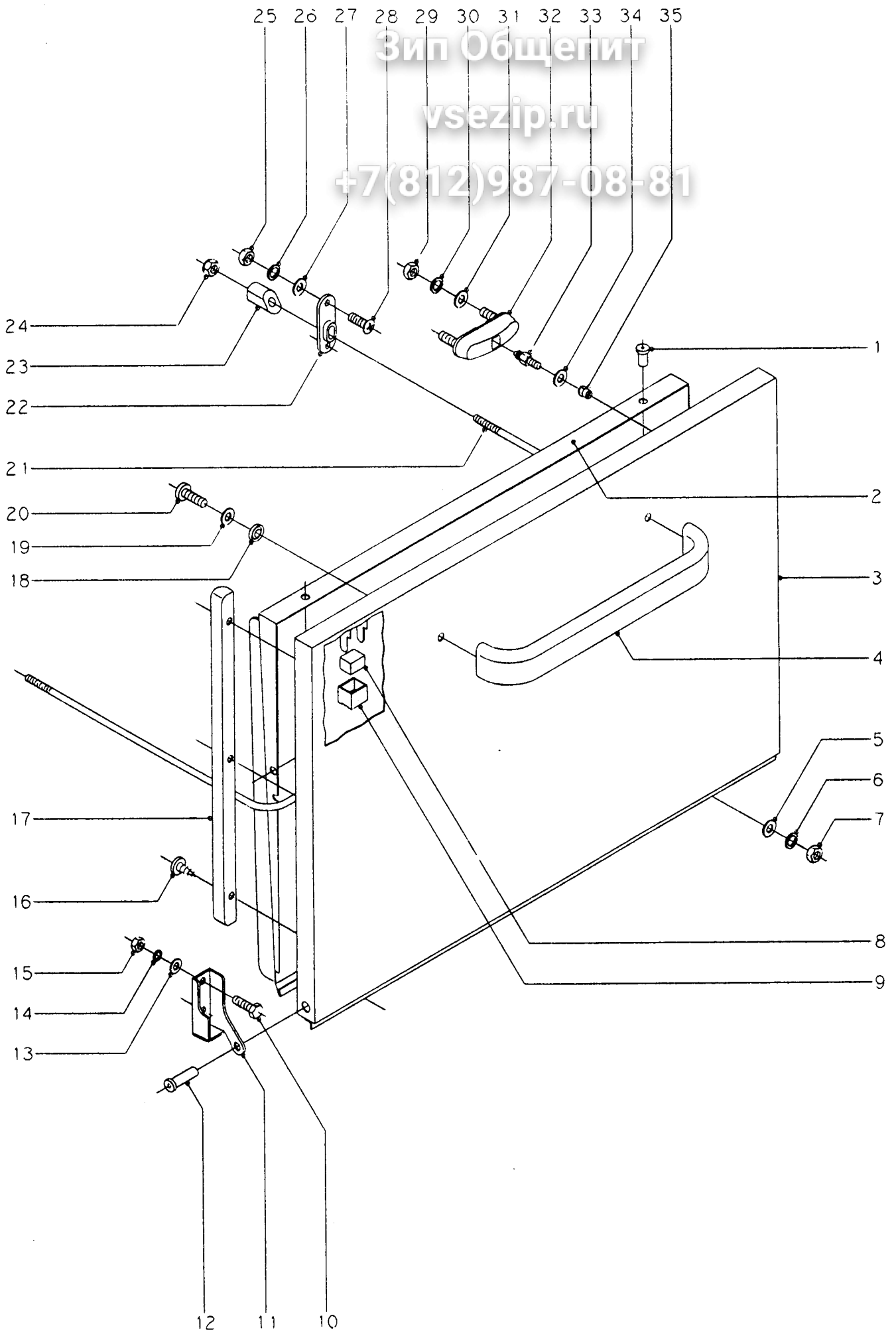

N plano	Firma	Fecha	Aprobado	Lamina	Fagor Industrial S Coop. FAGOR
C-461		7-97	LAVAVAJILLAS FI-30	2	Onote

Зип Ощепит

vsezip.ru

+7(812)987-08-81

CONCEPTO: PUERTA
SUJET: PORTE
CONCEPT: DOOR

LAMINAN°
VUE N°
ILUSTR. N.

2

APARATO - APPAREIL - APPLIANCE: LAVAVAJILLAS - LAVEVAISSELLES - DISH WASHING MACHINE

MODELO Y CANTIDAD - MOD. I

N°	CODIGO	DENOMINACION	DENOMINATION	DESCRIPTION	FI-30		
1	Q412000	Remache tubular Ø 4x8	Rivet Ø 4x8	Rivet Ø 4x8	4		
2	Z200545	Contrapuerta soldada	Contreporte	Inner panel for door	1		
3	Z200541	Puerta soldada	Panneau de porte	External panel for door	1		
4	Z200512	Asa puerta	Poignée	Door handle	1		
5	Q232030	Arandela plana A.5	Rondelle A.5	Washer A.5	2		
6	Q262030	Arandela muelle A.5	Rondelle A.5	Washer A.5	2		
7	Q162030	Tuerca exagonal M.5	Ecrou M.5	Nut M.5	2		
8	Z200506	Imán	Aimant	Magnet	1		
9	Z200507	Protector imán	Protection d'aimant	Magnet protection	1		
10	Q012042	Tornillo exagonal M.6x15	Vis M.6x15	Bolt M.6x15	4		
11	Z400514	Bisagra izquierda	Charnière gauche	Left hinge	1		
s/n	Z400515	Bisagra derecha	Charnière droite	Right hinge	1		
12	Z400516	Eje puerta	Axe de porte	Axle of door	2		
13	Q232040	Arandela plana A.6	Rondelle A.6	Washer A.6	4		
14	Q262040	Arandela muelle A.6	Rondelle A.6	Washer A.6	4		
15	Q162040	Tuerca exagonal M.6	Ecrou M.6	Nut M.6	4		
16	Q152005	Tornillo alomado 4,2x13	Vis 4,2x13	Bolt 4,2x13	6		
17	Z200524	Macro puerta	Cadre de porte	Frame of door	2		
18	Q308002	Arandela dubo A.6	Rondelle A.6	Washer A.6	2		
19	Q232040	Arandela plana A.6	Rondelle A.6	Washer A.6	2		
20	Q062041	Tornillo alomado M.6x10	Vis M.6x10	Bolt M.6x10	2		
21	Z200521	Varilla tensor	Baguette	Rod	1		
22	Z200310	Soporte tensor	Support	Support	2		
23	Z200522	Tensor de puerta	Tendeur de porte	Tightener	2		
24	Q222012	Tuerca autoblocante M.6	Ecrou M.6	Nut M.6	2		
25	Q162030	Tuerca exagonal M.5	Ecrou M.5	Nut M.5	4		
26	Q262030	Arandela muelle A.5	Rondelle A.5	Washer A.5	4		
27	Q232030	Arandela plana A.5	Rondelle A.5	Washer A.5	4		
28	Q152004	Tornillo aplastado M.5x13	Vis M.5x13	Bolt M.5x13	4		
29	Q162040	Tuerca exagonal M.6	Ecrou M.6	Nut M.6	4		
30	Q262040	Arandela muelle A.6	Rondelle A.6	Washer A.6	4		

Зип Общепит

vsezip.ru

(812)987-08-81

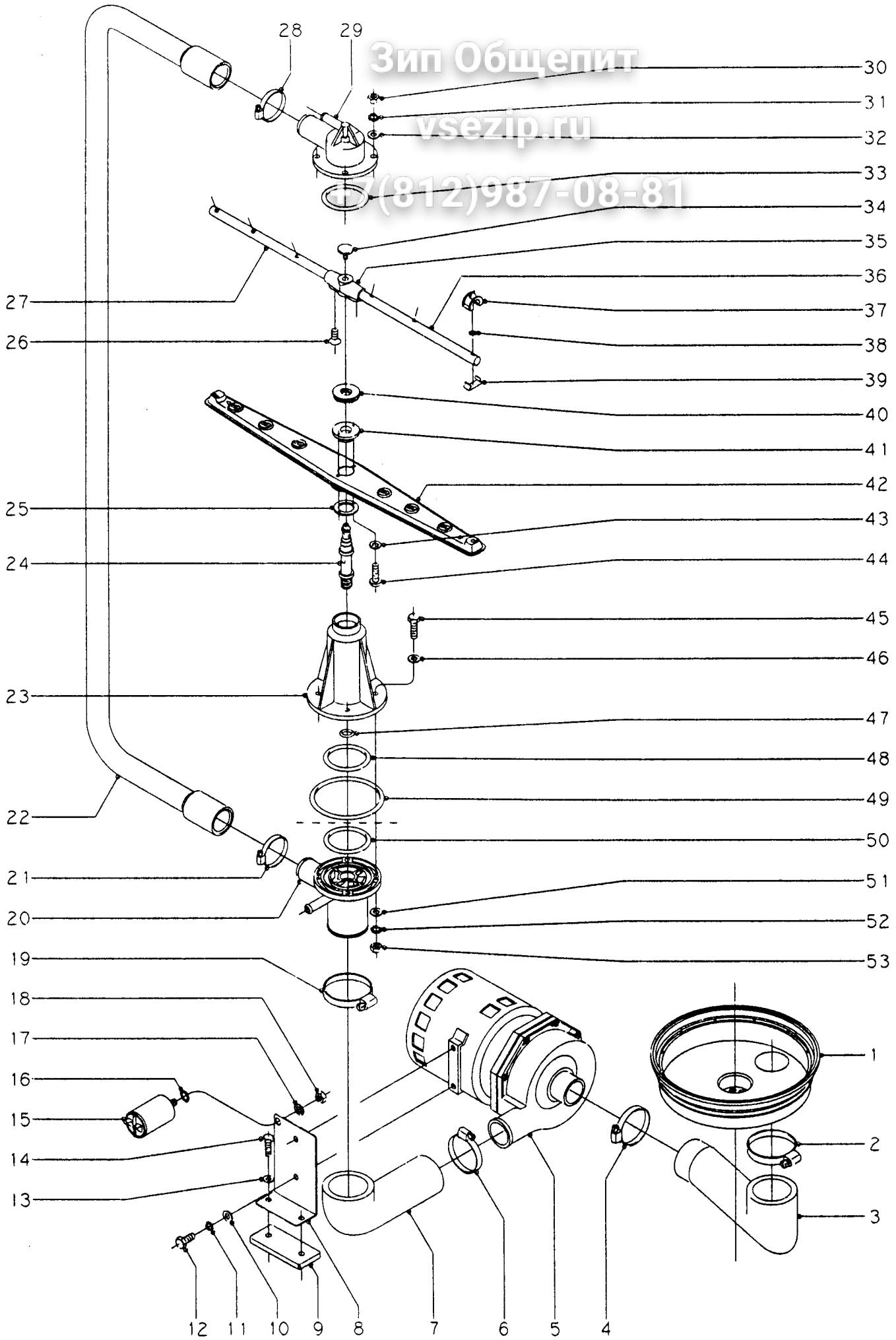

N plano	Firma	Fecha	Aparato	Lamina	Fagor Industrial S. Coop. FAGOR
C-462		7-97	LAVAVAJILLAS FI-30	3	

Зип Ощепит

vsezip.ru

+7(812)987-08-81

CONCEPTO: PARTE FUNCIONAL DE LAVADO
SUJET: SYSTEME DE LAVAGE
CONCEPT: WASHING SYSTEM

LAMINAN°
VUE N°
ILUSTR. N.

3

APARATO - APPAREIL - APPLIANCE: LAVAVAJILLAS - LAVEVAISSELLES - DISH WASHING MACHINE

MODELO Y CANTIDAD - MOD. I

N°	CODIGO	DENOMINACION	DENOMINATION	DESCRIPTION	FI-30		
1	Z200906	Cubeta	Cuve	Tank	1		
2	Q881324	Abrazadera 50-70	Collier 50-70	Worm clamp 50-70	1		
3	Z200904	Codo aspiración	Coude aspiration	Suction elbow	1		
4	Q881307	Abrazadera 40-60	Collier 40-60	Worm clamp 40-60	1		
5	Z201011	Bomba de lavado (230V 50Hz)	Pompe de lavage (230V 50Hz)	Washing pump (230V 50Hz)	1		
5	Z203511	Bomba de lavado (230V 60Hz)	Pompe de lavage (230V 60Hz)	Washing pump (230V 60Hz)	1		
s/n	Z201081	Conjunto junta y retén	Ensemble joint-bague d'étanchéi.	Joint-retainer	1		
s/n	Z201082	Turbina 50 Hz. (Ø 88 mm)	Turbine 50 Hz. (Ø 88 mm)	Turbine 50 Hz. (Ø 88 mm)	1		
s/n	Z203571	Turbina 60 Hz. (Ø 77 mm)	Turbine 60 Hz. (Ø 77 mm)	Turbine 60 Hz. (Ø 77 mm)	1		
6	Q881307	Abrazadera 40-60	Collier 40-60	Worm clamp 40-60	1		
7	Z200905	Codo impulsión	Coude d'impulsion	Impulsion elbow	1		
8	Z201002	SopORTE motobomba	Support de pompe	Pump support	1		
9	Z201003	Base bomba lavado	Base de pompe	Pump base	1		
10	Q232040	Arandela plana A.6	Rondelle A.6	Washer A.6	2		
11	Q262040	Arandela muelle A.6	Rondelle A.6	Washer A.6	2		
12	Q012041	Tornillo exagonal M.6x10	Vis M.6x10	Bolt M.6x10	2		
13	Q232030	Arandela plana A.5	Rondelle A.5	Washer A.5	2		
14	Q012033	Tornillo exagonal M.5x20	Vis M.5x20	Bolt M.5x20	2		
15	V321300	Condensador 10 uF	Condensateur	Condenser	1		
16	Q307048	Junta tórica	Joint	Joint	1		
17	Q242050	Arandela abanico A.8	Rondelle A.8	Washer A.8	1		
18	Q162050	Tuerca exagonal M.8	Ecrou M.8	Nut M.8	1		
19	Q881324	Abrazadera 50-70	Collier 50-70	Worm clamp 50-70	1		
20	Z200703	Pasamuros	Passe-murs	Support	1		
21	Q881305	Abrazadera 25-40	Collier 25-40	Worm clamp 25-40	1		
22	Z200706	Arbol de lavado	Conduite de lavage	Washing conduit	1		
23	Z200701	SopORTE distribuidor inferior	Support	Support	1		
24	Z200704	Eje central	Axe	Axle	2		
25	Z650711	Amarre enganche distribuidor	Rondelle de fixation	Fastening washer	2		
26	Q152024	Tornillo avellanado M.4x8	Vis M.4x8	Bolt M.4x8	4		
27	Z201902	Rama aclarado izquierda	Branche de rinçage gauche	Left rinsing branch	2		

Зип Общепит

vsezip.ru

+7(812)987-08-81

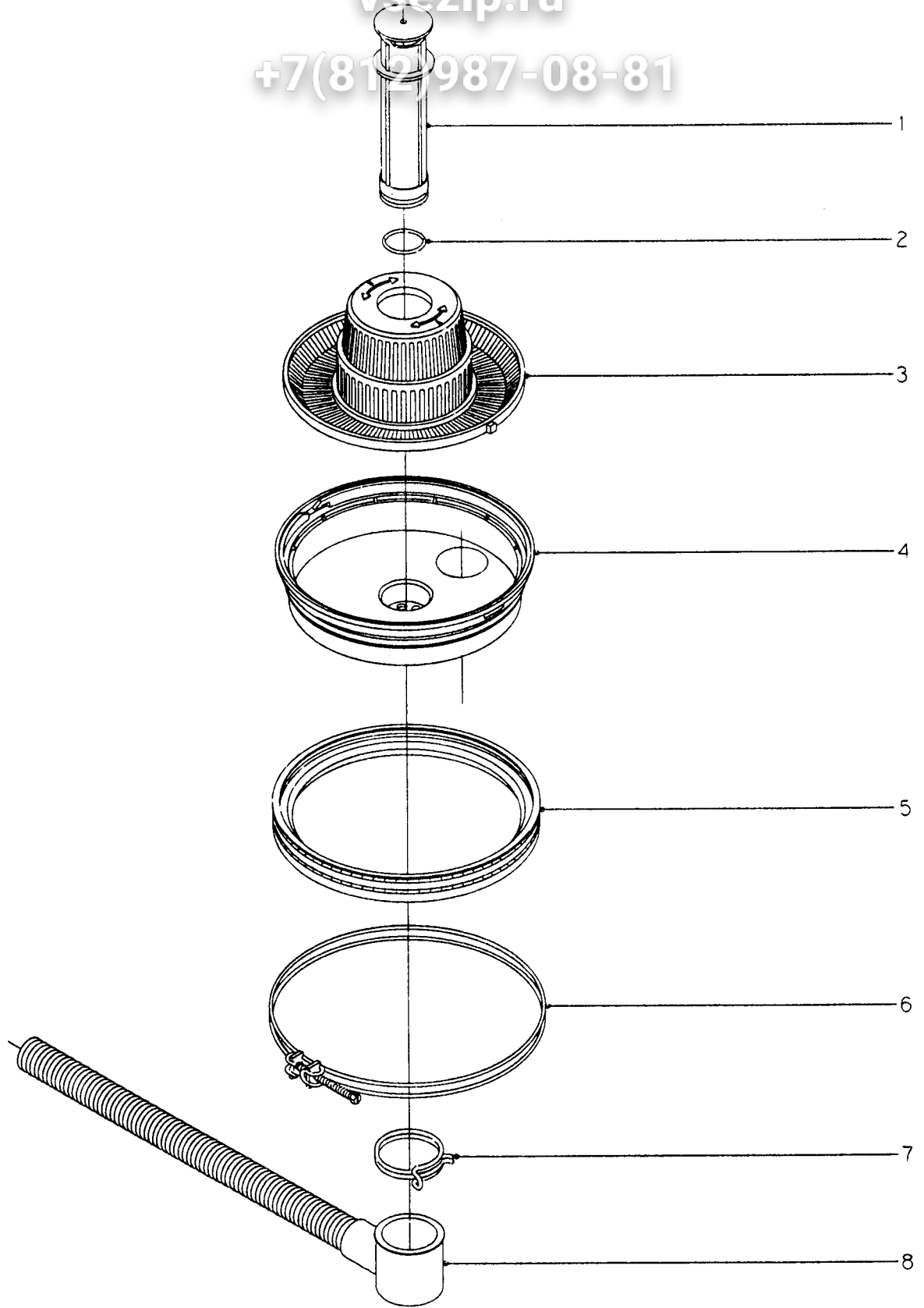

N plano	Firma	Fecha	Aparato	Laminas	Fagor Industrial S Coop
C-463		7-97	LAVAVAJILLAS FI-30	4	FAGOR
					Orate

Зип Общепит

vsezip.ru

+7(812)987-08-81

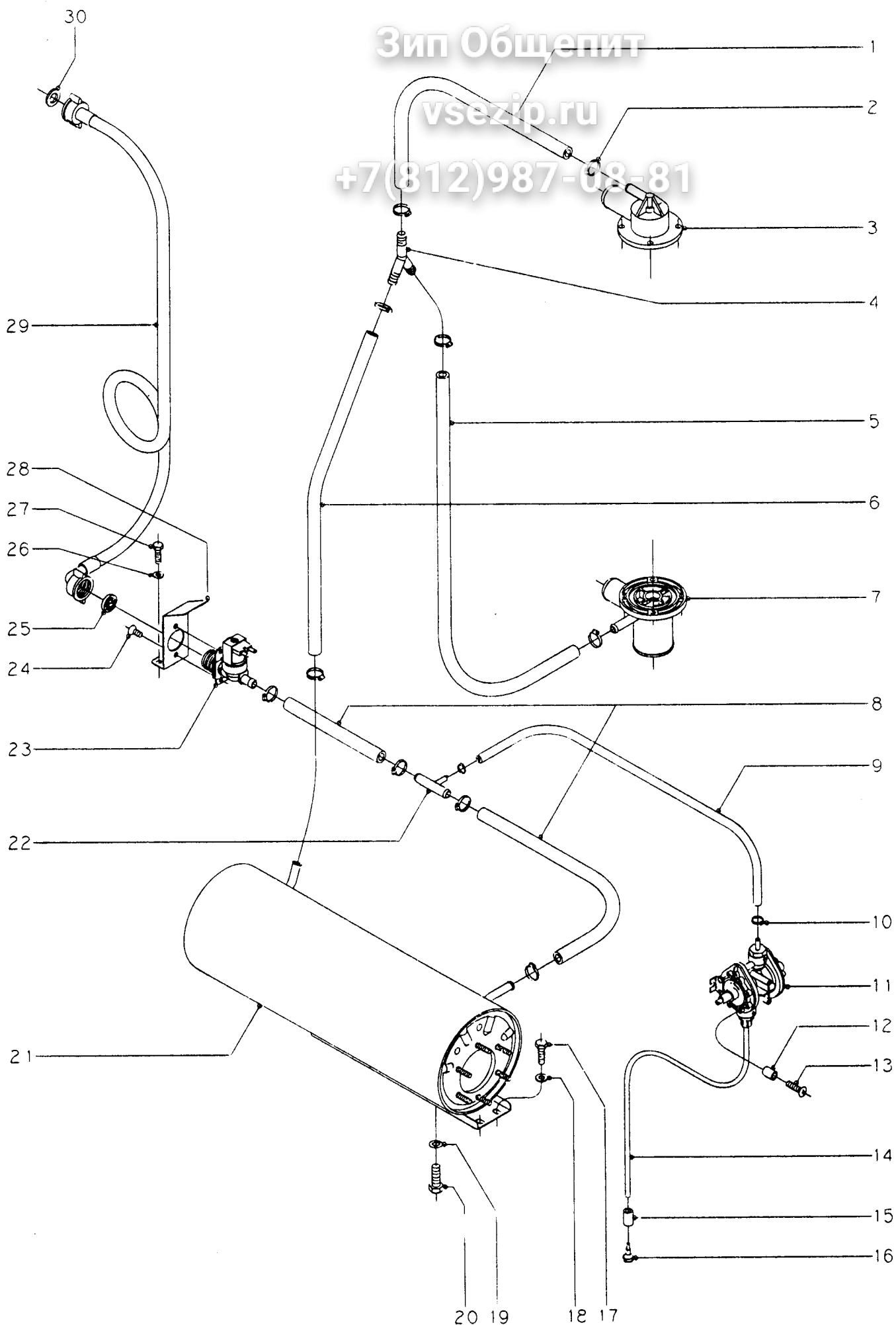

N plano	Firma	Fecha	Aprobado	Lamina	Fagor Industrial S.Coop. FAGOR
C-464		7-97	LAVAVAJILLAS FI-30	5	Дата

Зип Общепит

vsezip.ru

+7(812)987-08-81

CONCEPTO: PARTE FUNCIONAL DEL ACLARADO
SUJET: SYSTEME DE RINÇAGE
CONCEPT: RINSING SYSTEM

LAMINAN°
VUE N°
ILUSTR. N.

5

APARATO - APPAREIL - APPLIANCE: LAVAVAJILLAS - LAVEVAISSELLES - DISH WASING MACHINE

MODELO Y CANTIDAD - MOD. I

N°	CODIGO	DENOMINACION	DENOMINATION	DESCRIPTION	FI-30		
1	Z201105	Tubo de goma Ø10xØ17x360	Tube caoutchouc Ø10xØ17x360	Rubber tube Ø10xØ17x360	1		
2	Q881302	Abrazadera 12-20	Collier 12-20	Worm clamp 12-20	10		
3	Z200707	Soporte distribuidor superior	Support distributeursuperieur	Upper distributor support	1		
4	Z201106	Racord en Y	Raccord en Y	Union Y	1		
5	Z201103	Tubo de goma Ø10xØ17x780	Tube caoutchouc Ø10xØ17x780	Rubber tube Ø10xØ17x780	1		
6	Z201104	Tubo de goma Ø10xØ17x560	Tube caoutchouc Ø10xØ17x560	Rubber tube Ø10xØ17x560	1		
7	Z200703	Pasamuros	Passe-murs	Cross part	1		
8	Z201102	Tubo de goma Ø10xØ17x80	Tube caoutchouc Ø10xØ17x80	Rubber tube Ø10xØ17x80	2		
9	Z201109	Tubo termaprés Ø5xØ10,5x450	Tube caoutchouc Ø5xØ10,5x450	Rubber tube Ø5xØ10,5x450	1		
10	Q881308	Abrazadera 8-14	Collier 8-14	Worm clamp 8-14	2		
11	Z651123	Dosificador tensoactivo	Dosseur liquide tensio-actif	Doser of capillary activator	1		
12	Z203007	Casquillo	Douille	Collar	2		
13	Q041324	Tornillo avellanado M.4x25	Vis M.4x25	Bolt M.4x25	2		
14	Z230903	Conducto tensoactivo Ø6xØ4x1500	Conduit liq.tens.Ø6xØ4x1500	Capil.activ.ductØ6xØ4x1500	1		
15	Z701152	Peso filtro	Poids filtre	Filter weight	1		
16	Z601153	Filtro aspiración tensoactivo	Filtre	Filter	1		
17	Q012031	Tornillo exagonal M.5x10	Vis M.5x10	Bolt M.5x10	2		
18	Q232030	Arandela plana A.5	Rondelle A.5	Washer A.5	2		
19	Q307048	Junta tórica Ø9,12xØ16,18x3,53	JointØ9,12xØ16,18x3,53	JointØ9,12xØ16,18x3,53	1		
20	Q012063	Tornillo exagonal M.10x20	Vis M.10x20	Bolt M.10x20	1		
21	Z201701	Cuerpo calderín	Corps chaudière	Boiler body	1		
22	Z601157	Toma presión	Prise de pression	Pressure tap	1		
23	Z701135	Electroválvula entrada agua	Electrovanne entrée eau	Electric valve for water entry	1		
24	Q152024	Tornillo avellanado M.4x8	Vis M.4x8	Bolt M.4x8	2		
25	Z701132	Filtro junta	Filtre	Filter	1		
26	Q232030	Arandela plana A.5	Rondelle A.5	Washer A.5	2		
27	Q012031	Tornillo exagonal M.5x10	Vis M.5x10	Bolt M.5x10	2		
28	Z201101	Escuadra amarre electroválvula	Equerre fixation electrovanne	Electric valve fastening frame	1		
29	Z602121	Manguera entrada agua	Entrée d'eau	Pipe	1		
30	Q307031	Arandela junta	Rondelle joint	Joint washer	1		

Зип Общепит

vsezip.ru

+7(812)987-08-81

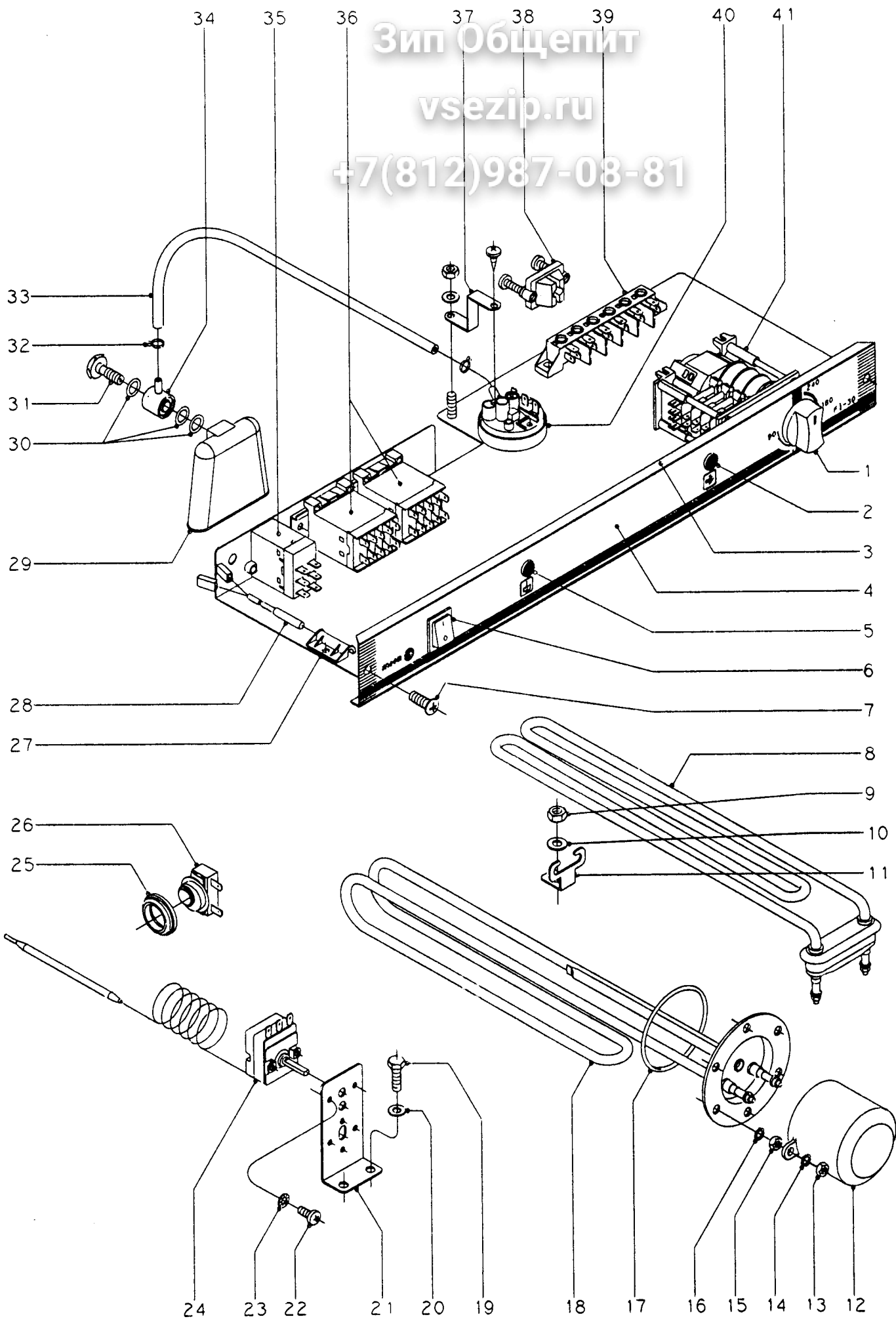

Зип Общепит

vsezip.ru

+7(812)987-08-81

CONCEPTO: PARTE FUNCIONAL ELECTRICA
SUJET: SYSTEME ELECTRIQUE
CONCEPT: ELECTRICAL SYSTEM

LAMINAN°
VUE N°
ILUSTR. N.

6

APARATO - APPAREIL - APPLIANCE: LAVAVAJILLAS - LAVEVAISSELLES - DISH WASHING MACHINE

MODELO Y CANTIDAD - MOD. I

N°	CODIGO	DENOMINACION	DENOMINATION	DESCRIPTION	FI-30		
1	R663062	Botón de mando	Bouton de commutateur	Knob	1		
2	Z203005	Piloto ambar	Témoin ambar	Lamp ambar	1		
3	Z202907	Frente extraible	Front	Front	1		
4	Z202909	Embelledor adhesivo	Plaque adhesive	Adhesive plate	1		
5	Z203004	Piloto verde	Témoin vert	Green lamp	1		
6	Z203033	Interruptor general	Interrupteur	Switch	1		
7	Q152004	Tornillo aplastado M.5x13	Vis M.5x13	Bolt M.5x13	2		
8	Z203601	Resistencia tanque	Résistance cuve	Tank heating element	1		
9	Q162040	Tuerca exagonal M.6	Ecrou M.6	Nut M.6	1		
10	Q232040	Arandela plana A.6	Rondelle A.6	Washer A.6	1		
11	Z603602	Soporte resistencia tanque	Support résistance cuve	Tank heating element support	1		
12	Z651731	Caperuza resistencia calderín	Chapeau résistance chaudière	Boiler resistance hood	1		
13	Q162040	Tuerca exagonal M.6	Ecrou M.6	Nut M.6	2		
14	Q262040	Arandela muelle A.6	Rondelle A.6	Washer A.6	2		
15	Q162040	Tuerca exagonal M.6	Ecrou M.6	Nut M.6	6		
16	Q262040	Arandela muelle A.6	Rondelle A.6	Washer A.6	6		
17	Q307035	Junta tórica AN-36	Joint torique AN-36	O-ring seal AN-36	1		
18	Z201706	Resistencia calderín	Résistance chaudière	Boiler resistance	1		
19	Q012031	Tornillo exagonal M.5x10	Vis M.5x10	Bolt M.5x10	2		
20	Q232030	Arandela plana A.5	Rondelle A.5	Washer A.5	2		
21	Z203016	Soporte termostato	Support thermostat	Thermostat support	1		
22	Q153111	Tornillo alomado M.4x8	Vis M.4x8	Bolt M.4x8	2		
23	Q242020	Arandela abanico A.4	Rondelle A.4	Washer A.4	2		
24	Z203014	Termostato calderín	Thermostat chaudière	Thermostat boiler	1		
25	N503017	Soporte termostato	Support thermostat	Thermostat support	1		
26	Z653013	Termostato doble (tanque)	Thermostat cuve	Tank thermostat	1		
27	Z203010	Amarre interruptor magnético	Fixation interrupteur magnet.	Fastening for magnet switch	1		
28	Z203009	Interruptor magnético	Interrupteur magnetique	Magnet switch	1		
29	Z203011	Cámara presostato	Chambre pressostat	Presostat chamber	1		
30	Q307003	Junta tórica Ø16,01xØ10,77x2,62	JointØ16,01xØ10,77x2,62	JointØ16,01xØ10,77x2,62	3		
31	Z203013	Tornillo presostato	Vis presostat	Pressostat bolt	1		

26 27
Зип Общепит

vsezip.ru

+7(812)987-08-81

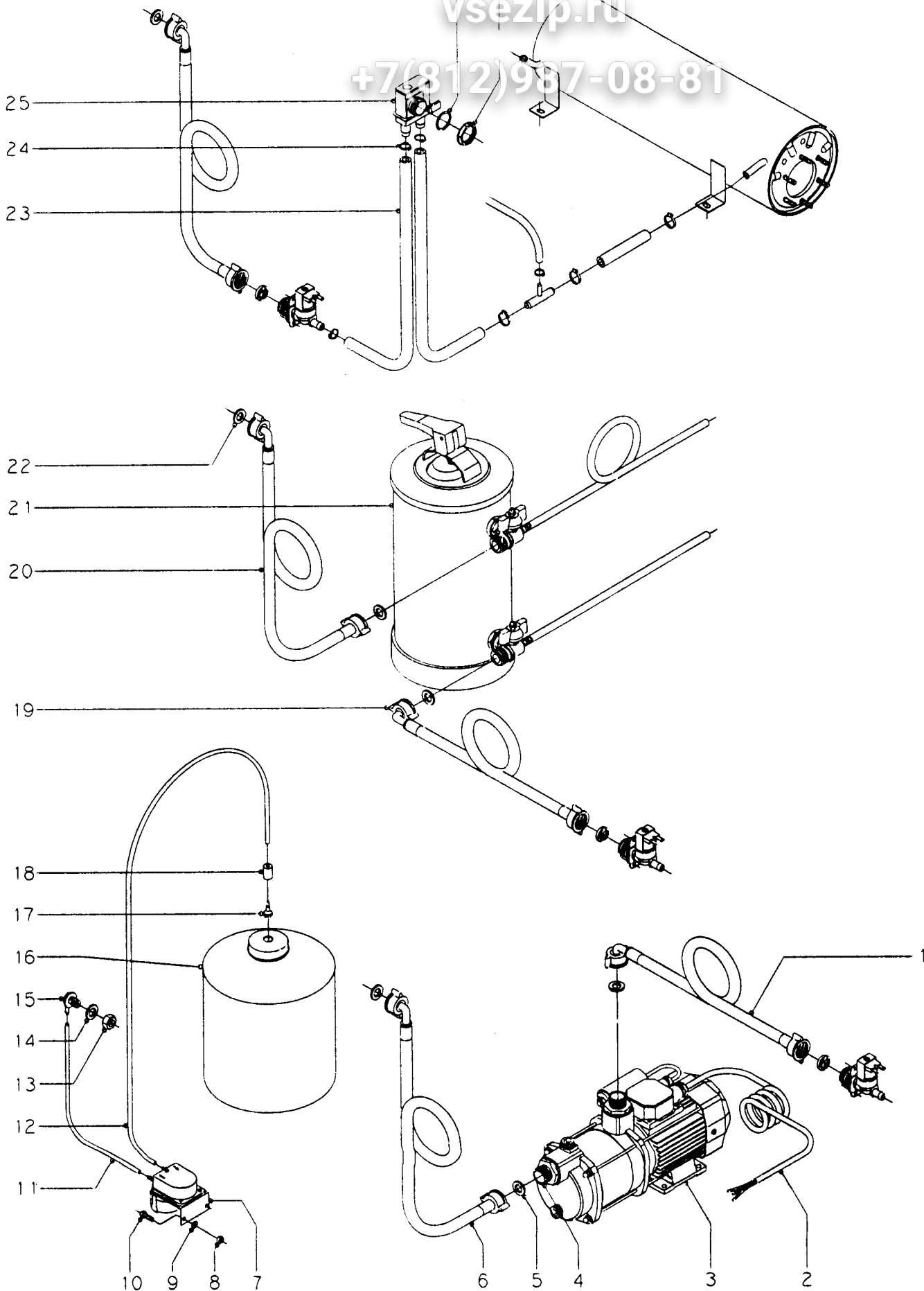

N plano C-466	Firno <i>[Signature]</i>	Fecha 7-97	Aparato ACCESORIOS LAVAVAJILLAS	Lamina —	Fagor Industrial S.Coop. FAGOR Date
------------------	-----------------------------	---------------	------------------------------------	-------------	---

