

Зип Общепит

vsezip.ru

+7(812)987-08-81

tav. C
Detail C
Detail C
Détail C

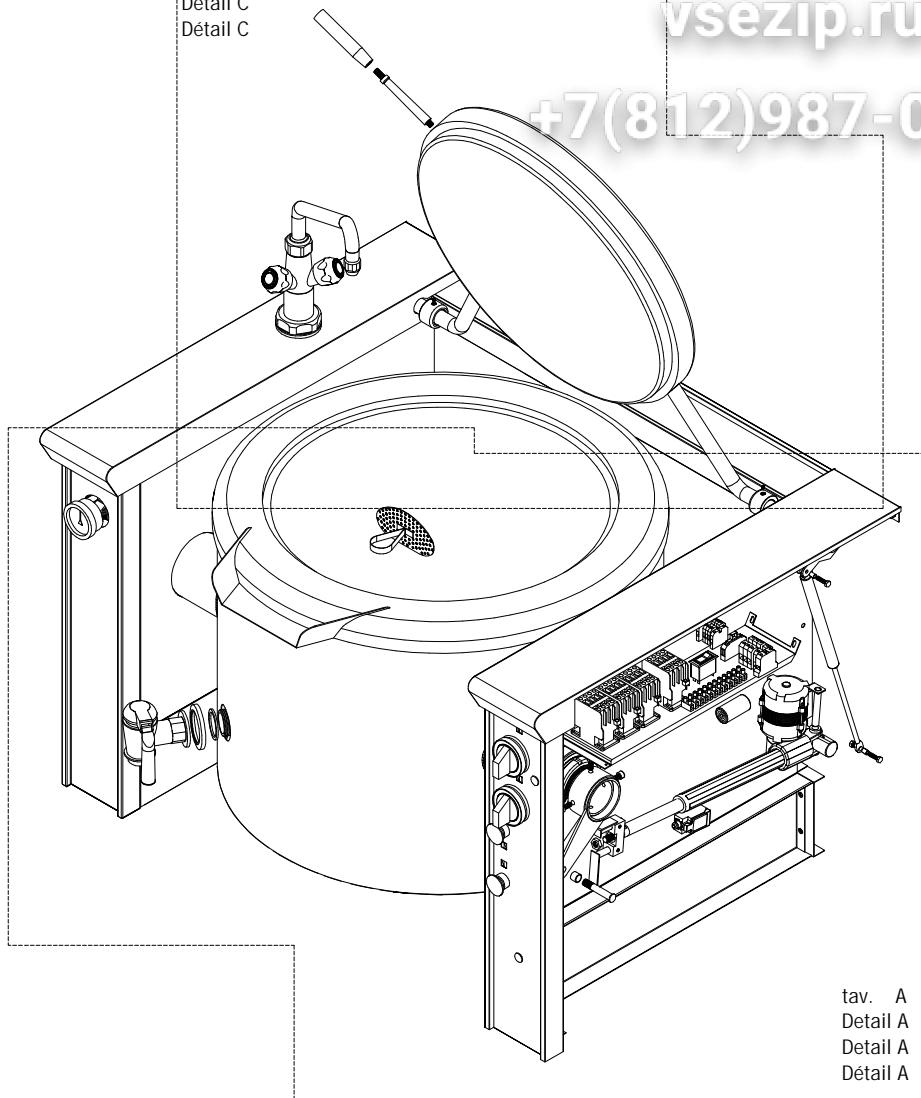

tav. A
Detail A
Detail A
Détail A

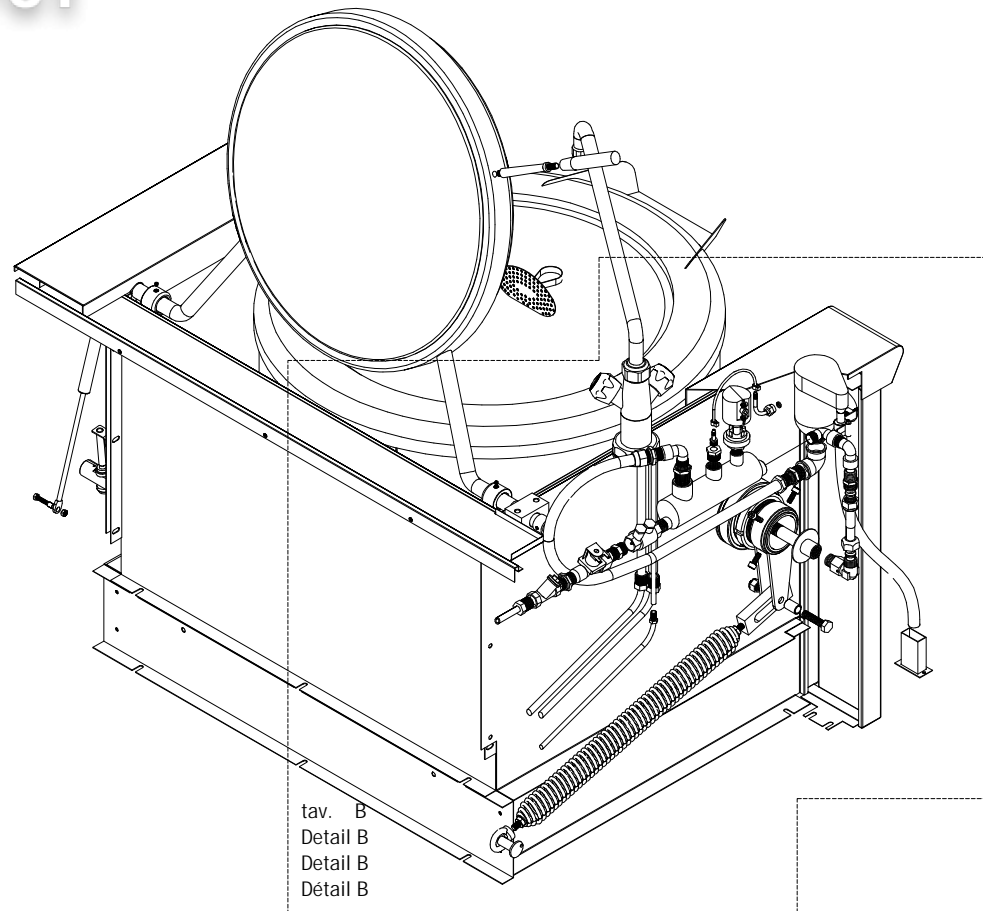

tav. B
Detail B
Detail B
Détail B

Serie Serie Série	Modello Modell Modél	Codice Kodex Code	Tav. Detail Détail
SYSTEM 900	EKK/100	0107015105	
Primo numero di serie Erste Seriennummer First serial number Première numéro de série	Ultimo numero di serie Letzte Seriennummer Last serial number Dernière numéro de série	Revisione Revision Revision Révision	00
Disegnato Gezeichnet	Approvato Geprüft	File Datei	Data Datum
T. Tschigg	<i>[Signature]</i>	EKK100.DWG	20/06/00
			39052 Kallern-Caldaro-ITALY Tel. 0471-662213 Telefax 0471-662065
GROSSKÜCHENTECHNIK - GRANDI CUCINE			

Зип Общежит

vse.ru

+7(812)987-08-81

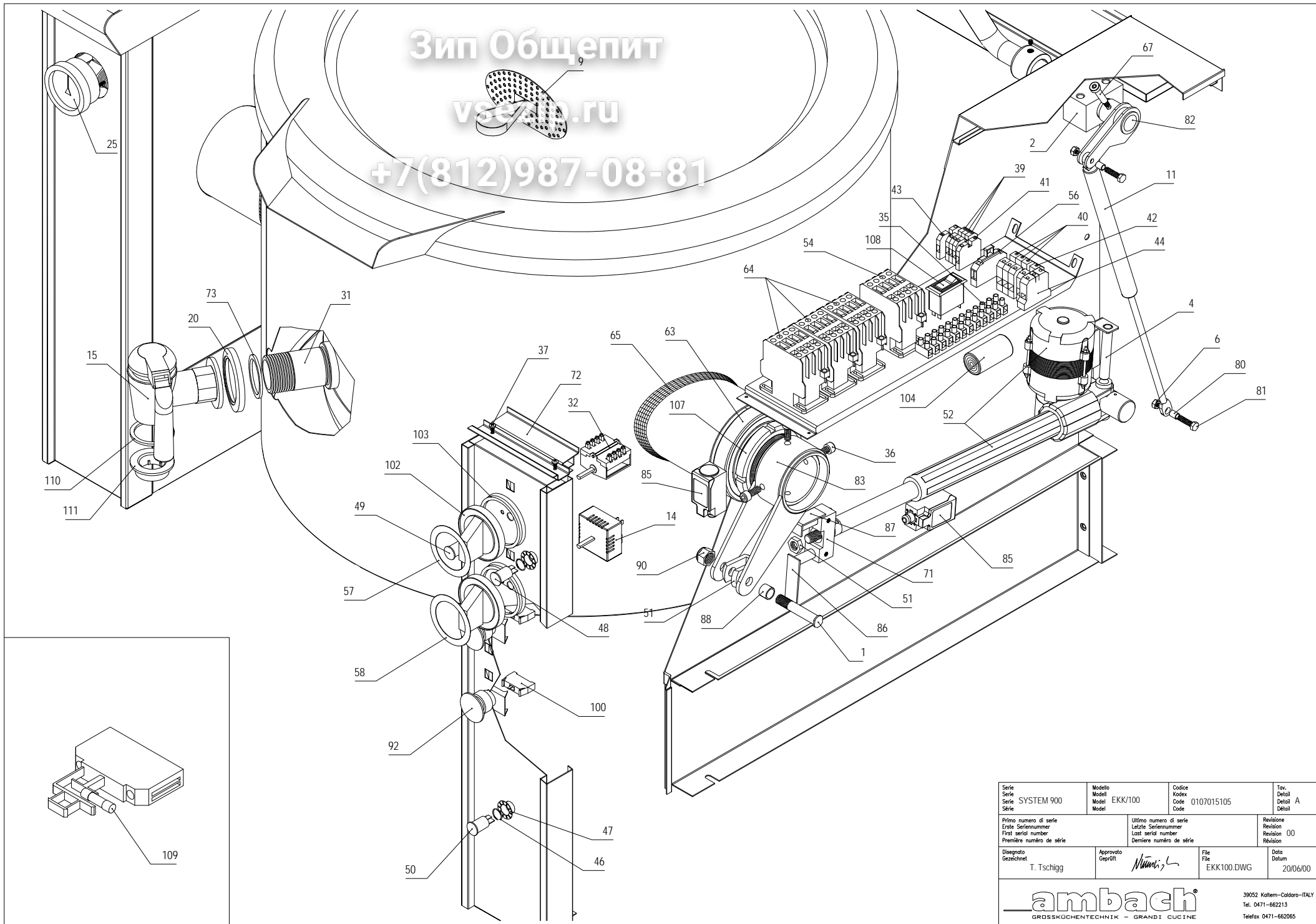

Зип Общепит

vsezip.ru

+7(812)987-08-81

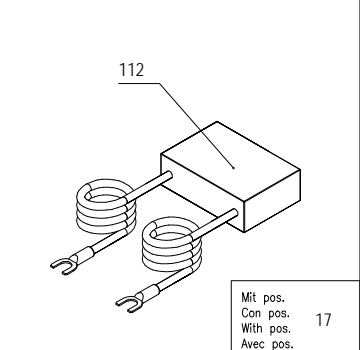
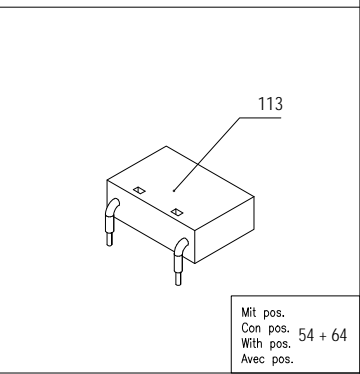
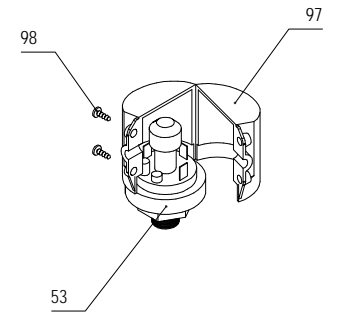
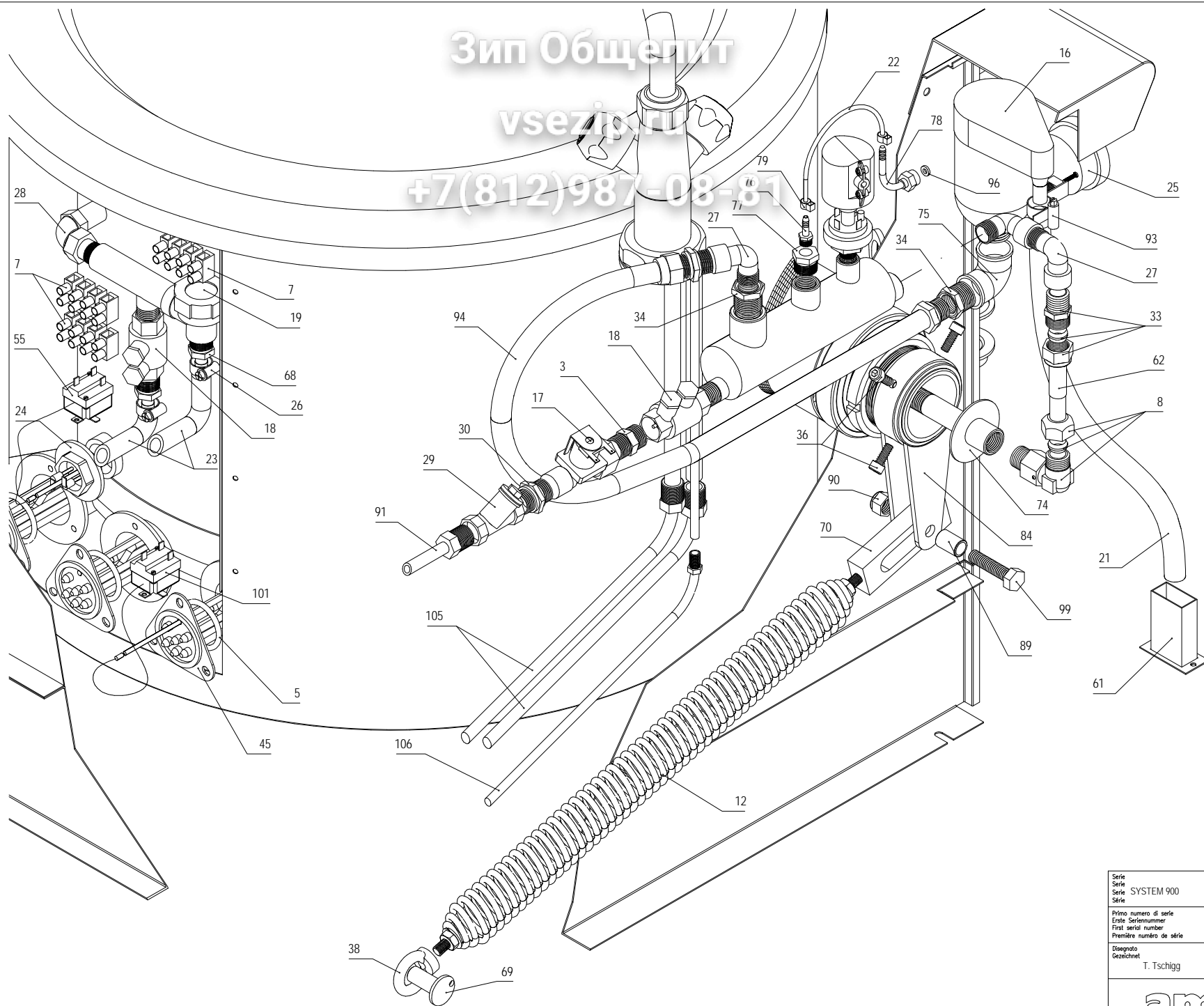

Serie Serie Série Série	Modello Modell Model Model	Codice Kodex Code Code	Tav. Detail Détail Detail
SYSTEM 900	EKK100	0107015105	B
Primo numero di serie Erste Seriennummer First serial number Première numéro de série	Ultimo numero di serie Letzte Seriennummer Last serial number Dernière numéro de série	Revisione Revision Revision Révision	00
Disegnato Gezeichnet	Approvato Geprüft	File Date	Data Datum
T. Tschigg	<i>[Signature]</i>	EKK100.DWG	20/06/00

Зип Общепит

vsezip.ru

+7(812)987-08-81

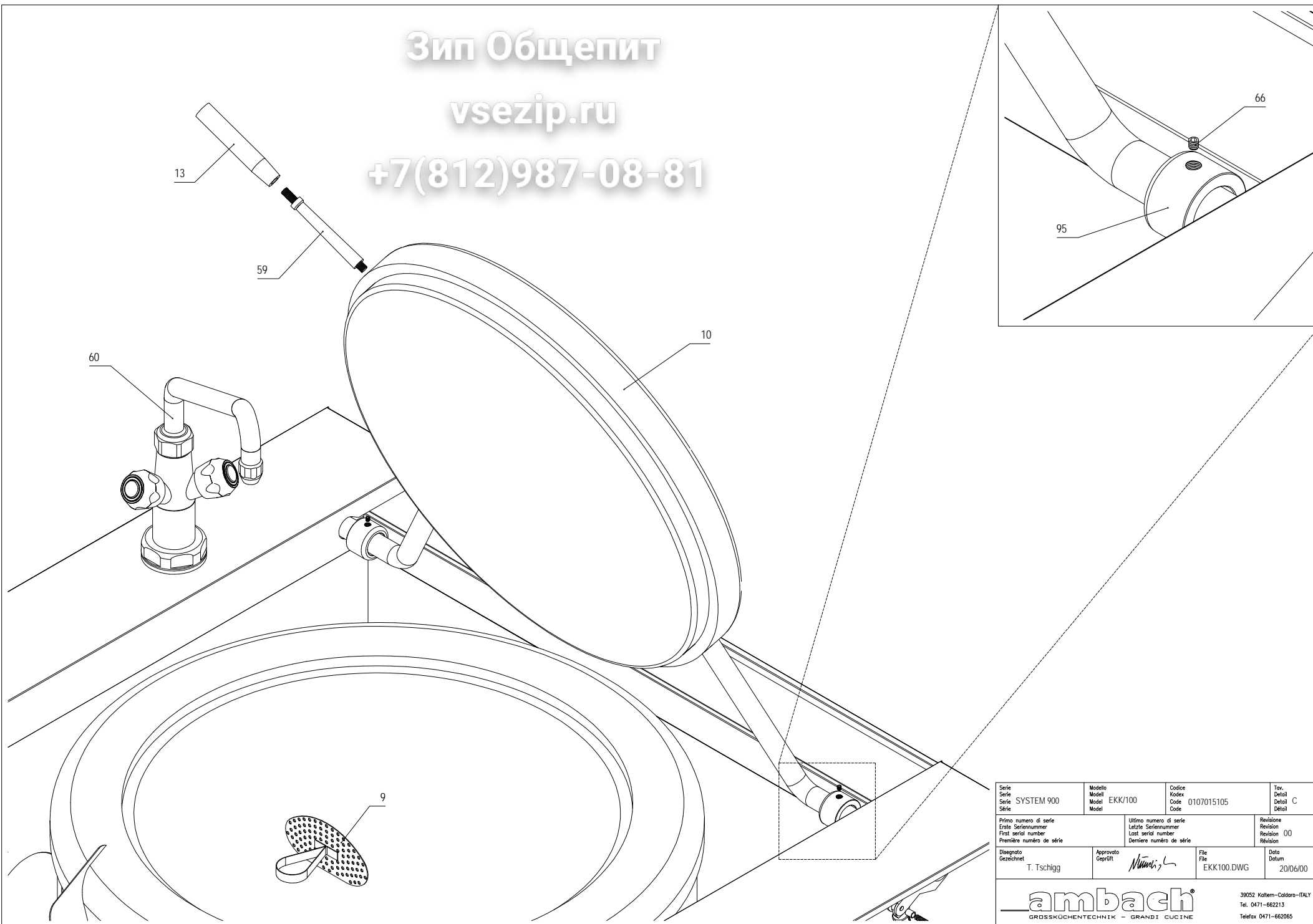

Serie Série Série SYSTEM 900	Modello Modell Model EKK/100	Codice Kodex Code 0107015105	Tav. Detail Detail C
Primo numero di serie Erste Seriennummer First serial number Première numéro de série	Ultimo numero di serie Letzte Seriennummer Last serial number Dernière numéro de série	Revisione Revision Revision 00	
Disegnato Gezeichnet T. Tschigg	Approvato Geprüft 	File Datei EKK100.DWG	Data Datum 20/06/00
ambach® GROSSKÜCHENTECHNIK - GRANDI CUCINE			39052 Kallern-Caldaro-ITALY Tel. 0471-662213 Telefax 0471-662065

0107015105 Model: EKK/100
Elektro Kippkochkessel 100 Liter
Electric tilting kettle 100 litres

Pentola rovesciabile elettrica 100 litri
Marmite basculante électrique 100 litres

Code	Beschreibung	Descrizione	Description	Désignation	St/Qty	Start	Finish	SerialNr.
1	3001115561	Schraube Spindelmotor	Vite attuatore	Screw spindle motor	Vis de moteur basculement	KB/KK	1	
2	3008915518	Lager Deckelhub	Cuscinetto coperchio	Cover bearing	Palier de couvercle	KB/KK	2	
3	3017215110	Düse Wassereinlauf	Ugello entrata acqua	Water entry jet	Gicleur pour alimentation d'eau	Eco/System	1	
4	3509611373	Stift Spindelmotor	Perno attuatore	Pin spindle motor	Tige de moteur	KB/KK	1	09/01/98
5	5017313781	Gummidichtung O-Ring	Guarnizione o-ring	Rubber gasket o-ring	Joint torique en caoutchouc	EUK/45	3	
6	5040310815	Mutter 6kt	Dado esagonale	Hexagon nut	Ecrou hexagonal	M6 Inox 18/8	2	
7	3560510386	Anschlußklemme 4P	Morsettiere 4P	Connection terminal 4P	Borne de raccordement 4P	PA/76 Sez-6	3	
8	4551207219	Winkelgelenk	Raccordo gomito girevole	Angle joint	Raccord coudé pivotant	26 421 R 1/2"	1	17/02/98
9	5000800745	Abdeckung Auslauf Kochkessel	Filtro scarico pentola	Boiling pan drain filter	Crépine de marmite	1" 1/2 D=440	1	
10	5003104149	Deckel doppelwandig	Coperchio + controbombato	Double walled cover	Couvercle à double paroi	KK	1	
11	5004714039	Feder Deckelhub	Molla alzacoperchio	Spring cover lifting	Ressort pour levage couvercle	KB/System	1	
12	5004715273	Zugfeder Kipper	Molla reazione brasiera	Driving spring tilting	Ressort de traction basculement	KB/EKK	1	
13	5005607080	Griff Deckel	Maniglia coperchio	Cover handle	Poignée de couvercle	M 10 KSK	1	
14	5061616087	Energieregler	Regolatore d'energia	Energy controller	Doseur d'énergie	230V 12A	1	
15	5018013159	Sicherheitsentleerhahn	Rubinetto scarico	Pet safety cock	Robinet de vidange	1 1/2"	1	
16	5018015600	Einbau Sicherheitsventil	Valvola di sicurezza interna	Internal safety valve	Soupape de sûreté intérieure	3/4"	1	
17	5018106153	Elektroventil 1/2"	Elettrovalvola 1/2"	Electric valve 1/2"	Electrovanne 1/2"	KMG/KME/50	1	
18	5018114399	Rückschlagventil	Valvola di ritegno	Return valve	Soupape de retenue	Roma 1/2	2	
19	5018117567	Kondensabscheider	Scaricatore di condensa	Condense drainage	Vidange condensât	1/2" BPT13AX-G	1	
20	5022210634	Rosette	Ghiera	Round plate	Rosace	1.1/2" KK	1	
21	5024608002	Wasserschlauch	Tubo acqua	Water tube	Tuyau d'eau	PE/PK1/40	0,7	
22	5024610547	Silikonschlauch	Tubo silicone	Silicone tube	Tuyau en silicone	ø5mm>ø8mm	0,6	
23	5024610572	Wasserschlauch	Tubo acqua	Water tube	Tuyau d'eau	ø10mm	1	
24	5024709751	Pilot Heizkörper	Resistenza controllo acqua	Heating element pilot	Résistance double enveloppe	KSK/150-250	1	
25	5027210517	Manometer	Manometro	Manometer	Manomètre	ESK/GSK	1	
26	5028510569	Rohrschelle	Fascetta per tubo	Pipe clamp	Collier de serrage pour tuyau	D=20/0 W1	2	25/01/99
27	5050101267	Bogen Messing M+W	Angolo ottone M+F	Elbow brass M+F	Raccord coudé en laiton M+F	1/2" Art. 458	2	
28	5050120029	Bogen + Holländer	Gomito ottone	Elbow brass	Raccord coudé	R 19 - 1/2"	1	
29	5050915915	Filter in Messing	Filtro in ottone	Brass filter	Filtre en laiton	1/2"	1	
30	5051001287	Doppelnippel Messing	Nipplo doppio ottone	Double nipple brass	Double raccord en laiton	1/2" Art.441	1	
31	5051013255	Nippel Auslauf	Nipplo scarico	Drain nipple	Raccord fileté de vidange	EKK/40-100	1	
32	5060904035	Stufenschalter 4P	Commutatore 4P	Step switch 4P	Commutateur à gradins 4 pos.		1	
33	5051220023	Rohrverschraubung Messing	Raccordo ottone	Brass pipe union	Raccord vissé en laiton	MS 1/2">16	3	
34	5051310309	Reduzierung 3/4">1/2"	Riduzione 3/4">1/2"	Adapter 3/4">1/2"	Douille de réduction 3/4">1/2"	Art. 448	1	
35	5060508821	Anschlußklemme	Morsettiere	Connection terminal	Borne de raccordement	PA/44 Sez-4	1	
36	5041402628	Zylinderschraube in. 6kt	Vite tcei	Hexagon cylinder screw	Vis cylindrique hexagonale	M8x20 Inox	8	
37	5041703368	Zylinderblechschraube	Vite autofilettante	Cylinder parker screw	Vis à tête cylindrique	3,9x9,5	4	
38	5006310539	Halter Feder Inox	Supporto molla inox	Spring holder inox	Support de ressort en inox	M10	1	
39	5060513981	Universalklemme grau	Morsetto universale grigio	Grey universal terminal	Borne universelle grise	6QMM	3	
40	5060513982	Universalklemme grau	Morsetto universale grigio	Grey universal terminal	Borne universelle grise	16QMM	3	
41	5060513984	Null-Leiterklemme blau	Morsetto neutro blu	Blue neutral terminal	Borne neutre bleue	6QMM	1	
42	5060513985	Null-Leiterklemme blau	Morsetto neutro blu	Blue neutral terminal	Borne neutre bleue	16QMM	1	

43	5060513987	Erdungsklemme gelb/grün	Morsetto terra giallo/verde	Yellow/green ground terminal	Borne de terre jaune/verte	6QMM	1	
44	5060513988	Erdungsklemme gelb/grün	Morsetto terra giallo/verde	Yellow/green ground terminal	Borne de terre jaune/verte	16QMM	1	
45	5060810064	Heizkörper 6000W	Resistenza 6000W	Heating element 6000W	Résistance 6000W	KKE (IRCA)	3	
46	5017309716	Silikonchtring	Guarnizione anello silicone	Silicon sealing ring	Bague d'étanchéité en silicone	D=18/16x0,5	2	
47	5040209715	Befestigungsscheibe	Rondella fissaggio	Fastening washer	Rondelle de fixation	D=26 Di=15	2	
48	5061111121	Signalleuchte weiß	Lampada spia bianca	White control lamp	Voyant lumineux blanc	230V T150° C	1	
49	5061109898	Signalleuchte gelb	Lampada spia gialla	Yellow control lamp	Voyant lumineux jaune	230V T150° C	1	
50	5061113846	Signalleuchte grün	Lampada spia verde	Green control lamp	Voyant lumineux verte	230V	1	12/10/00 841148
	5061110293	Signalleuchte rot	Lampada spia rossa	Red control lamp	Voyant lumineux rouge	230V T150° C	1	12/10/00
51	5061214600	Gabel für Spindelmotor	Forcella anteriore	Force for spindle motor	Fourche moteur de bascule.	Catr33	1	
52	5061214601	Spindelmotor Catr33 200mm	Attuatore Catr33 200mm	Spindle motor Catr33 200mm	Moteur bascul. Catr33 200mm	33x200x1/220	1	
53	5061315480	Druckwächter Dampfüberwach.	Pressostato controllo vapore	Pressure switch steam control	Pressostat - contrôle de vapeur		1	
54	5061407226	Schütz CGE CL25	Contattore CGE CL25	Contactore CGE CL25	Contacteur-disjunc. CGE CL25	A300T6 230V	1	
55	5061609772	Thermostat Wasserfüllung	Termostato controllo livello	Thermostat water control	Thermostat contrôle niveau eau	KSK	1	
56	5061807908	Sicherungshalter	Porta fusibile	Fuse holder	Porte-fusible	Siemens	1	
57	5022914336	Knebelscheibe Elt.	Anello manopola elt.	Tommy disk electric	Rondelle de poignée électrique	0-1-2-3	1	
58	5022914340	Isolierblech außen	Lamiera isolante esterna	External insulation plate	Tôle isolante extérieure	EKB/120	1	
59	5006801972	Isolierung durablanket	Isolazione durablanket	Durablanket insulation	Isolation durablanket	KK	1	
60	5024550861	Standsäule	Colonnina	Column	Colonne d'eau		1	
61	3500515329	Rohr Ablauf Mitte	Tubo scarico centrale	Middle drain tube	Tuyau de vidange central	SYSTEM-BF	1	
62	5000511919	Rohr Drehgelenk	Tubo raccordo girevole	Turning knuckle tube	Raccord de tube tournant	EKK/40-250	1	
63	5008505691	Kugellager	Cuscinetto a sfera	Ball bearing	Roulement à billes	6016-2RS	2	
64	5061411123	Schütz CGE CL02	Contattore CGE CL02	Contactore CGE CL02	Contacteur-disjunc. CGE CL02	A400T6	3	
65	5017315500	Dichtung Einfassung	Guarnizione piano	Seal top	Joint plan de cuisson	System	1	
66	5040811648	Gewindestift innen 6kt	Perno filettato esagonale	Hex-socket set screw	Vis hexagonale sans tête	M5x6 Inox	2	
67	5041810579	Zylinderspezialschraube	Vite tc cava es.	Hexagon cylinder screw	Vis à tête cylindrique spéciale	8x30 M6	1	
68	5051210544	Schlauchverschraubung	Portagomma cilindrico	Flexible tube connection	Raccord fileté de flexible	1/2">ø12	2	
69	5009614955	Stift Feder	Perno molla	Spring pin	Goupille de ressort	KB/KK	1	
70	3006315590	Halter Feder vorne	Supporto molla anteriore	Spring holder in front	Support de ressort avant	KB/KK	1	
71	3006314960	Halter Anschläge Motor	Supporto cammes	Motor stroke holder	Support butée de moteur	KB/KK	1	
72	3000813148	Abdeckung Wasser Schaltbl.	Protezione acqua cruscotto	Water protection control panel	Protection d'eau panneau cde	KB/KK	2	
73	5017323620	Dichtung Sicherheitsentleerha.	Guarnizione rubinetto scarico	Pet safety cock seal	Joint de robinet de vidange	1 1/2"	1	
74	5000515806	Rohr Wassereinfluss	Tubo erogazione acqua	Water supply tube	Tuyau d'alimentation d'eau	EKK	1	
75	5050120702	Bogen Messing	Gomito ottone	Elbow brass	Raccord coudé en laiton	Fig. 90 - 3/4"	1	
76	5051210546	Schlauchverschraubung	Portagomma cilindrico	Flexible tube connection	Raccord fileté de flexible	1/4">ø7	1	
77	5051310364	Reduzierung Messing	Riduzione ottone	Brass adapter	Douille de réduction en laiton	1/2">1/4" Art. 448	2	
78	5051212578	Winkelanschluß	Raccordo a gomito	Angle fitting	Raccord à vis coudé	MS 1/4"	1	
79	5028510548	Schlauchschelle	Fascetta stringitubo	Pipe clamp	Collier de serrage de tuyau	ø7,5>9mm	2	
80	3027615545	Hülse Deckelhub	Boccola	Cover bush	Manchon de couvercle		1	
81	5041003117	Schraube 6kt	Vite te esagonale	Hexagon screw	Vis hexagonale	M6x25 Inox	2	
82	3506315459	Hebel Deckelhub	Leva coperchio	Cover lever	Levier de couvercle	EKK/100	1	
83	3506315119	Halter Welle Wanne rechts	Supporto asse destro	Right shaft holder basin	Support d'axe de cuve droite	KB/KK/SYSTEM	1	
84	3506315118	Halte Welle Wanne links	Supporto asse sinistro	Left shaft holder basin	Support d'axe de cuve gauche	KB/KK/SYSTEM	1	
85	5060909748	Endschalter ATO-11-2-i	Finecorsa ATO-11-2-i	Limit switch ATO-11-2-i	Interrupteur fin de c. ATO-11-2-i	K&M	2	
86	5001014947	Anschlag Endschalter unten	Battuta finecorsa inferiore	Stopper limit switch below	Butée interrupteur fin de c. bas	KB/KK	1	
87	5001014949	Anschlag Endschalter oben	Battuta finecorsa superiore	Stopper limit switch above	Butée interrupteur fin de c. haut	KB/KK	1	
88	3027615533	Hülse Schraube Spindelmotor	Boccola vite attuatore	Bush screw spindle motor	Manchon vis moteur	KB/KK	1	

Зип Общепит

Rev. 02 - 03/01

89	3027615534	Hülse Schraube Feder	Boccola vite molla	Bush screw spring	Manchon vis ressort	KB/KK	1		
90	5040310957	Mutter 6KT Autobl.	Dado esa. autobloccante	Hexagon screw autobl.	Ecrou hexagonal autobloquant	M12 INOX 18/8	2		
91	5024612525	Flexibler Stahlschlauch	Tubo flessibile	Flexible steel tube	Tuyau flexible en acier	L=900	1		
92	5018611265	Schalttaster	Pulsantiera	Push button	Commutateur	KB/50/90	2		
93	5028509493	Rohrschelle	Fascetta per tubo	Pipe clamp	Collier de serrage pour tuyau	D=32-50/13	1		
94	5024612563	Dampfschlauch Inox	Tubo teflon inox	Teflon flexible tube inox	Tuyau flexible téflon inox	L=310 3/4"	1		
95	3027615804	Hülse Abdeckung Welle	Boccola alzacoperchio	Bush shaft protection	Manchon protecteur axe	EKK/40-250	2		
96	5017313787	Dichtung Manometer	Guarnizione manometro	Manometer seal	Joint d'étanchéité manomètre		1		
97	5003116222	Deckel Druckwächter	Coperchio pressostato	Cover pressure control device	Couvercle pressostat		1		
98	5041703368	Zylinderblechschraube	Vite autofilettante	Cylinder parker screw	Vis à tête cylindrique	3,9x9,5	2		
99	5041010377	Schraube 6kt	Vite te esagonale	Hexagon screw	Vis hexagonale	M12x50 INOX 18/8	1		
100	5060911266	Schaltkontakt	Contatto cema	Switch push button contact	Interrupteur contact	KB/50/90	2		
101	5061600808	Sicherheitsthermostat	Termostato limitatore	Safety thermostat	Thermostat de sécurité	KSKE	1		
102	5022914031	Elektro Schaltknopf	Manopola elettrica	Electric knob	Bouton de commande élec.	S/90	2		
103	5017314030	Dichtung Schaltknopf	Guarnizione manopola	Switch seal	Joint de bouton de commande	VA 60	2		
104	5061211324	Kondensator MFL	Condensatore MFL	Condenser MFL	Condensateur MFL	250V 6,3MF	1		
105	5024612526	Flexibler Stahlschlauch	Tubo flessibile	Flexible steel tube	Tuyau flexible en acier	L=900	2		
106	5024612522	Flexibler Stahlschlauch	Tubo flessibile	Flexible steel tube	Tuyau flexible en acier	L=900	1		
107	5040003847	Nutmutter	Ghiera di bloccaggio	Groove nut	Ecrou cylindrique à encoches	M 80x2	2		
108	5060909759	Motorschutzschalter	Disgiuntore termico	Motor protection switch	Disjoncteur protection moteur	E-T-A 1A	1		
109	5061809773	Sicherung 8A	Fusibile 8A	Fuse 8A	Fusible 8A	TPME/KKME	2		
110	5017316243	Beilagscheibe Entleerhahn	Rondella rubinetto scarico	Washer for pet cock	Rondelle pour robinet de vidange	1 1/2"	1		
111	5022212341	Rosette für Entleerhahn	Ghiera per rubinetto scarico	Round plate for pet cock	Rosace pour robinet de vidange	1 1/2"	1		
112	5050909752	Schützentstörfilter	Filtro antidisturbo	Radioshielding filter	Filtre antiparasites	400 V	1	16/02/00	807011
113	5050912346	Schützentstörfilter	Filtro antidisturbo	Radioshielding filter	Filtre antiparasites	130/240 V	4	12/04/00	915097
	5003012322	Distanzstück Nippel Auslauf	Distanziale nipplo scarico	Spacer block drain nipple	Pièce interc. raccord fil. vidange	1 1/2"	1	20/03/01	799564