

Зип Общепит

DESPIECE TECNICO

vsezip.ru

+7(812)987-08-81

Lavavajillas arrastre de cinta
Lave-vaisselle entrainement à bande
Belt conveyor dishwasher
Transportband Geschirrspüler
Lavastoviglie con avanzamento a nastro

Modelos:

FI-2700

FI-4000

FI-6000

ECO-2700

ECO-4000

ECO-6000

Julio 2004 July



Fagor Industrial

Зип Общежит

vsezip.ru

+7(812)987-08181

N plano
C-1545

Firma

Fecha
7-2004

Aparato
LAVAVAJILLAS DE CINTA
MODULO DE ENTRADA

Lamina
1

Fagor Industrial S. Coop.
Onate

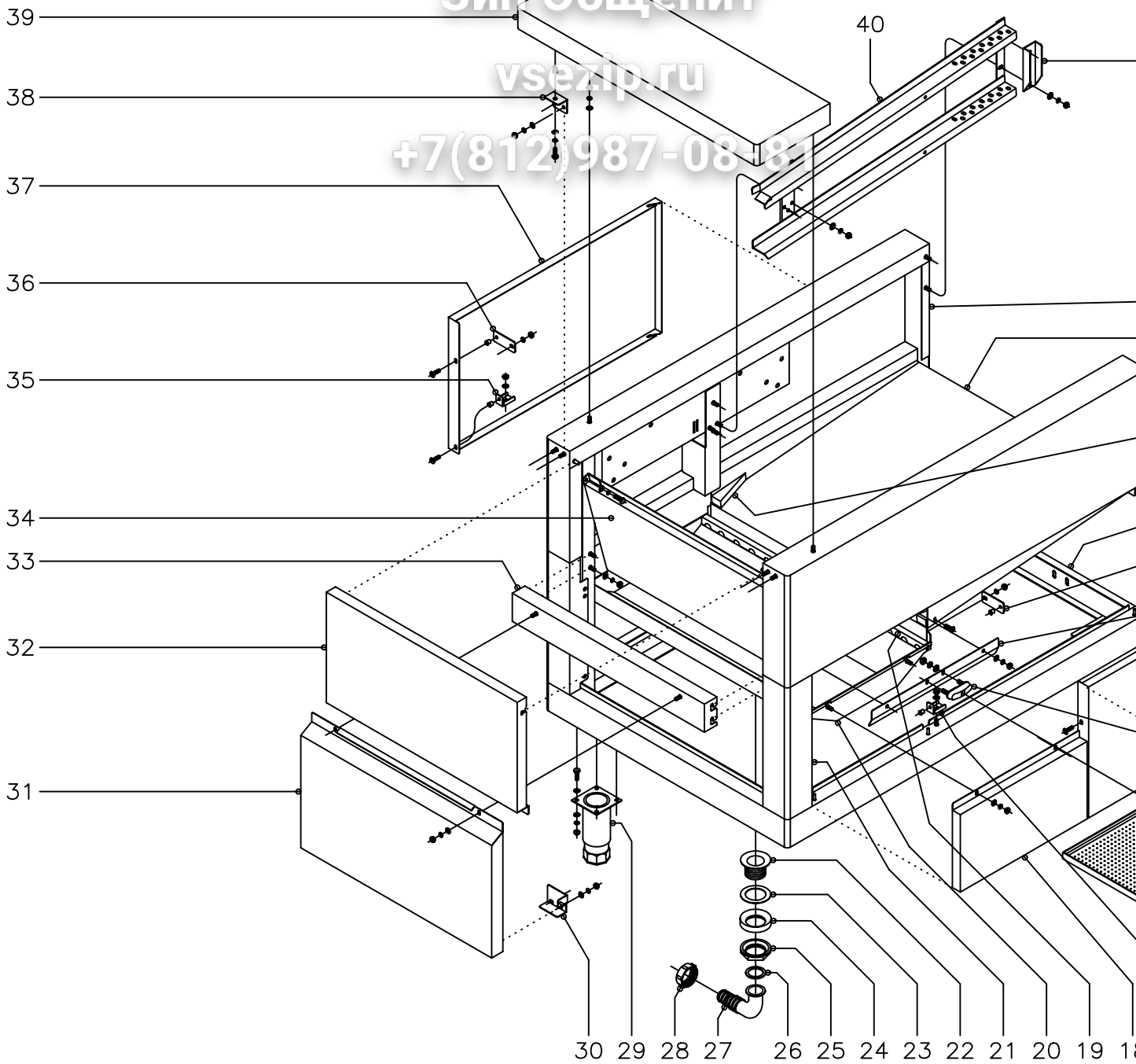

Зип Общепит

vsezip.ru

ZONA

MODULO DE ENT

MOD.

LAVAVAJILLAS DE CINTA

+7(812)987-08-81

ITEM	CODIGO	DENOMINACION	TEXTO	2700 I	2700 D	4000 I	4000 D
1	Z510408	Entrada izquierda soldada	Welded left inlet	1	1	1	1
2	Z510419	Fondo entrada completa	Complete inlet back	1	1	1	1
3	Z510415	Entrada derecha soldada	Welded right inlet	1	1	1	1
4	Z510435	Cantонера recogedor	Pick up corner protector	2	2	2	2
	Q152004	Tornillo aplastado M-5x13	Screw M-5x13	2	2	2	2
5	Z510401	Armazón entrada soldado	Welded inlet framework	1	1	1	1
6	Z512961	Amarre superior panel	Upper panel anchoring	1	1	1	1
	Q262040	Arandela muelle A-6	Spring washer A-6	1	1	1	1
	Q162040	Tuerca hexagonal M-6	Hexagonal nut M-6	1	1	1	1
	Q221342	Remache hexagonal M-5	Hexagonal rivet M-5	1	1	1	1
7	Z512905	Panel portamandos entrada	Inlet control panel	1	-	1	-
7	Z512906	Panel portamandos entrada	Inlet control panel	-	1	-	1
	Q152004	Tornillo aplastado M-5x13	Screw M-5x13	2	2	2	2
8	Z510472	Protector inf. fugas entrada	Lower protector escape inlet	2	2	2	2
	Q302022	Arandela plana Ø16xØ6x1,2	Flat washer Ø16xØ6x10.2	4	4	4	4
	Q262040	Arandela muelle A-6	Spring washer A-6	4	4	4	4
	Q162040	Tuerca hexagonal M-6	Hexagonal nut M-6	4	4	4	4
9	Z513006	Etiqueta circular amarillo	Round yellow label	1	1	1	1
10	Z513005	Interruptor de seta rojo	Round mushroom switch	1	1	1	1
11	Z513004	Pulsador rojo completo	Complete red push button	1	1	1	1
12	Z513003	Pulsador verde completo	Complete green push button	1	1	1	1
13	Z200607	Conjunto cierre	Closure set	2	2	2	2
	Q302022	Arandela plana Ø16xØ6x1,2	Flat washer Ø16xØ6x10.2	4	4	4	4
	Q262040	Arandela muelle A-6	Spring washer A-6	4	4	4	4
	Q162040	Tuerca hexagonal M-6	Hexagonal nut M-6	4	4	4	4
14	Z200601	Enganche cierre	Closure hook	2	2	2	2
	Q221342	Remache hexagonal M-5	Hexagonal rivet M-5	1	1	1	1
15	Z448703	Asa	Handle	2	2	2	2
	Q152004	Tornillo aplastado M-5x13	Screw M-5x13	4	4	4	4

Зип Общепит

vsezip.ru

ZONA

MODULO DE ENTRADA

LAVAVAJILLAS DE CINTA

+7(812)987-08-81

ITEM	CODIGO	DENOMINACION	TEXTO	2700 I	2700 D	4000 I	4000 D
	Q221342	Remache hexagonal M-5	Hexagonal rivet M-5	4	4	4	4
16	Z512915	Panel superior recogedor comp.	Complete pick up upper panel	2	2	2	2
17	Z512962	Sujeción inferior panel	Lower panel fastening	1	1	1	1
	Q302022	Arandela plana Ø16xØ6x1,2	Flat washer Ø16xØ6x10.2	1	1	1	1
	Q162040	Tuerca hexagonal M-6	Hexagonal nut M-6	1	1	1	1
	Q221304	Remache redondo M-5	Round rivet M-5	1	1	1	1
18	Z512918	Panel inferior recogedor	Pick up lower panel	2	2	2	2
	Q302022	Arandela plana Ø16xØ6x1,2	Flat washer Ø16xØ6x10.2	4	4	4	4
	Q262040	Arandela muelle A-6	Spring washer A-6	4	4	4	4
	Q162040	Tuerca hexagonal M-6	Hexagonal nut M-6	4	4	4	4
19	Z510434	Guía bandeja recogedor	Pick up tray guide	2	2	2	2
	Q152004	Tornillo aplastado M-5x13	Screw M-5x13	2	2	2	2
20	Z510431	Fondo recogedor soldado	Back welded pick up	1	1	1	1
	Q302022	Arandela plana Ø16xØ6x1,2	Flat washer Ø16xØ6x10.2	4	4	4	4
	Q262040	Arandela muelle A-6	Spring washer A-6	4	4	4	4
	Q162040	Tuerca hexagonal M-6	Hexagonal nut M-6	4	4	4	4
	Q412004	Remache monobolt Ø4,8	Monobolt rivet Ø40.8	4	4	4	4
21	Z510420	Cantonera	Corner protector	2	2	2	2
	Q412004	Remache monobolt Ø4,8	Monobolt rivet Ø40.8	12	12	12	12
22	Z102104	Válvula desagüe	Drainage valve	1	1	1	1
23	Q307009	Arandela junta Ø70xØ48x1,5	Joint washer Ø70xØ48x10.5	1	1	1	1
24	Q307026	Junta especial	Special joint	1	1	1	1
25	Z702101	Tuerca rosca 1 1/2"	Screw thread 1 1/2"	1	1	1	1
26	Q307027	Arandela junta Ø45xØ35x2	Joint washer Ø45xØ35x2	1	1	1	1
27	Z602101	Codo desagüe	Drainage elbow	1	1	1	1
28	Z602102	Tuerca	Nut	1	1	1	1
29	X260151	Pata regulable	Adjustable leg	4	4	4	4
	Q012043	Tornillo hexagonal M-6x20	Hexagonal screw M-6x20	16	16	16	16
	Q302022	Arandela plana Ø16xØ6x1,2	Flat washer Ø16xØ6x10.2	32	32	32	32

Зип Общепит

vsezip.ru

ZONA

MODULO DE ENTRADA

MOD.

LAVAVAJILLAS DE CINTA

+7(812)987-08-81

ITEM	CODIGO	DENOMINACION	TEXTO	2700 I	2700 D	4000 I	4000 D
	Q262040	Arandela muelle A-6	Spring washer A-6	16	16	16	16
	Q162040	Tuerca hexagonal M-6	Hexagonal nut M-6	16	16	16	16
30	Z512956	Soporte giro derecho completo	Complete right turn support	1	1	1	1
s/n	Z512958	Soporte giro izquierdo completo	Complete left turn support	1	1	1	1
	Q302022	Arandela plana Ø16xØ6x1,2	Flat washer Ø16xØ6x10.2	4	4	4	4
	Q262040	Arandela muelle A-6	Spring washer A-6	4	4	4	4
	Q162040	Tuerca hexagonal M-6	Hexagonal nut M-6	4	4	4	4
31	Z512919	Panel lateral inferior completo	Complete lower side panel	1	1	1	1
	Q302022	Arandela plana Ø16xØ6x1,2	Flat washer Ø16xØ6x10.2	2	2	2	2
	Q262040	Arandela muelle A-6	Spring washer A-6	2	2	2	2
	Q162040	Tuerca hexagonal M-6	Hexagonal nut M-6	2	2	2	2
32	Z512921	Panel lateral superior	Upper side panel	1	1	1	1
33	Z510413	Perfil tensor completo	Complete profile turnbuckle	1	1	1	1
	Q302022	Arandela plana Ø16xØ6x1,2	Flat washer Ø16xØ6x10.2	4	4	4	4
	Q262040	Arandela muelle A-6	Spring washer A-6	4	4	4	4
	Q162040	Tuerca hexagonal M-6	Hexagonal nut M-6	4	4	4	4
34	Z510473	Protección superior fugas entrada	Upper protection escape inlet	1	1	1	1
	Q012043	Tornillo hexagonal M-6x20	Hexagonal screw M-6x20	2	2	2	2
	Q302022	Arandela plana Ø16xØ6x1,2	Flat washer Ø16xØ6x10.2	2	2	2	2
	Q262040	Arandela muelle A-6	Spring washer A-6	2	2	2	2
35	Z512962	Sujeción inferior panel	Lower panel fastening	1	1	1	1
	Q302022	Arandela plana Ø16xØ6x1,2	Flat washer Ø16xØ6x10.2	1	1	1	1
	Q162040	Tuerca hexagonal M-6	Hexagonal nut M-6	1	1	1	1
	Q221304	Remache redondo M-5	Round rivet M-5	1	1	1	1
36	Z512961	Amarre superior panel	Upper panel anchoring	1	1	1	1
	Q262040	Arandela muelle A-6	Spring washer A-6	1	1	1	1
	Q162040	Tuerca hexagonal M-6	Hexagonal nut M-6	1	1	1	1
	Q221342	Remache hexagonal M-5	Hexagonal rivet M-5	1	1	1	1
37	Z512911	Panel posterior entrada izquierda	Left inlet rear panel	1	-	1	-

Зип Общежит

vsezip.ru

+7(812)987-08-81

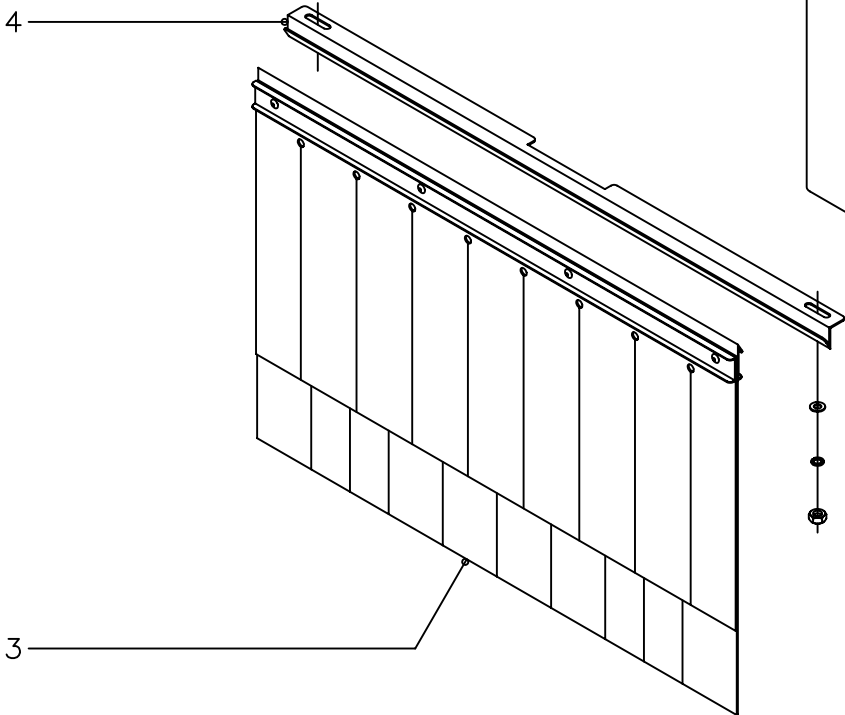
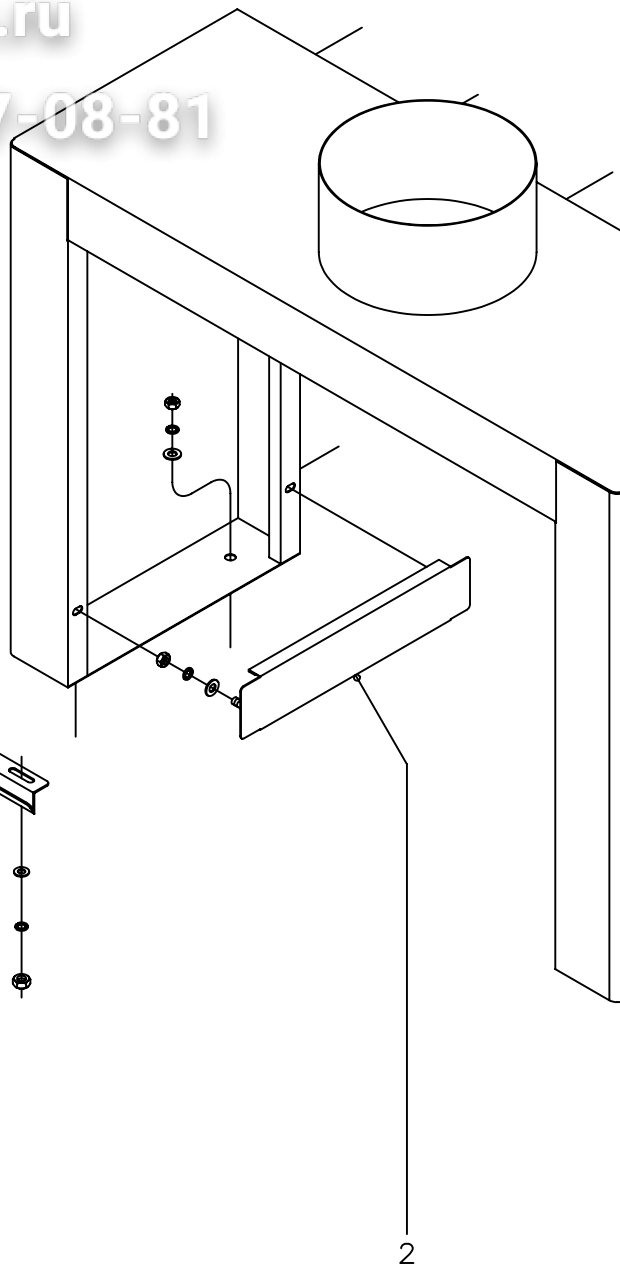

N plano C-1546	Firma 	Fecha 7-2004	Aparato LAVAVAJILLAS DE CINTA ASPIRADOR DE VAHOS	Lamina 2	Fagor Industrial S. Coop. Omate
-------------------	-----------	-----------------	--	-------------	------------------------------------

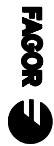

21 22

Зип Общепит

vsezip.ru

+7(812)987-08-81

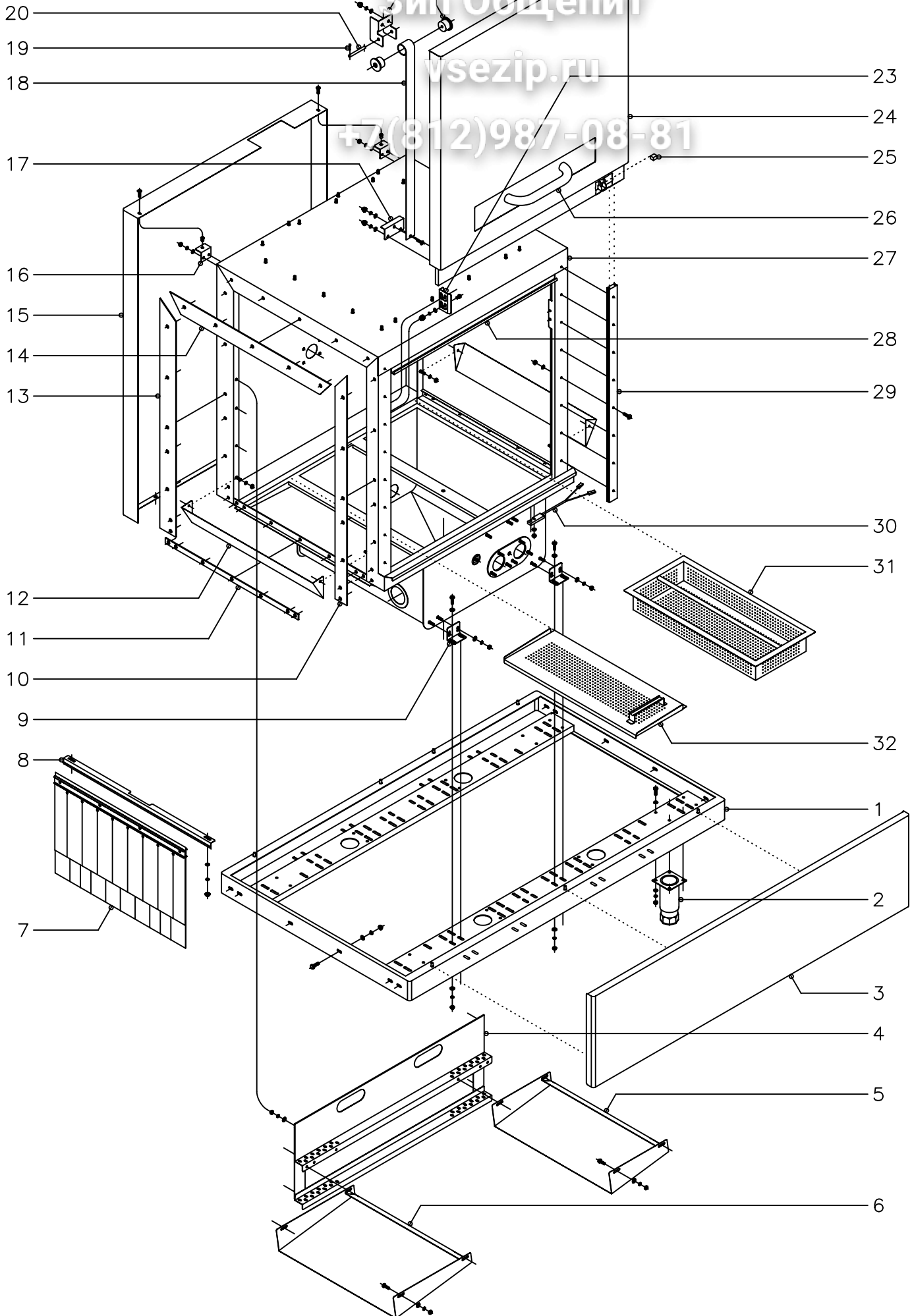

N plano C-1547	Firma 	Fecha 7-2004	Aparato LAVAVAJILLAS DE CINTA MODULO DE LAVADO (Mueble)	Lamina 3	Fagor Industrial S.Coop. FAGOR Onate
-------------------	-----------	-----------------	---	-------------	--

MOD.		LAVAVAJILLAS DE CINTA		ZONA		MODULO DE LAVADO ()			
ITEM	CODIGO	DENOMINACION	TEXTO	2700 I	2700 D	4000 I	4000 D		
1	Z510101	Armazón soldado (Lavad.-aclarad.)	Welded framework (Wash-rinse)	1	1	1	1		
1	Z530101	Armazón soldado (Lavado)	Welded framework (Wash)	-	-	1	1		
	Q012053	Tornillo hexagonal M-8x20	Hexagonal screw M-8x20	8	8	12	12		
	Q232050	Arandela plana A-8	Flat washer A-8	8	8	12	12		
	Q262050	Arandela muelle A-8	Spring A-8 washer	8	8	12	12		
	Q162050	Tuerca hexagonal M-8	Hexagonal nut M-8	8	8	12	12		
2	X260151	Pata regulable	Ajustable leg	4	4	8	8		
	Q012043	Tornillo hexagonal M-6x20	Hexagonal screw M-6x20	16	16	32	32		
	Q302022	Arandela plana Ø16xØ6x1,2	Flat washer Ø16xØ6x10.2	32	32	64	64		
	Q262040	Arandela muelle A-6	Spring washer A-6	16	16	32	32		
	Q162040	Tuerca hexagonal M-6	Hexagonal nut M-6	16	16	32	32		
3	Z512901	Panel frontal lavado y preaclarado	Washing and rinsing front panel	1	1	1	1		
3	Z532901	Panel frontal lavado	Washing front panel	-	-	1	1		
4	Z510321	Guía lavado completa	Complete washing guide	2	2	4	4		
	Q302022	Arandela plana Ø16xØ6x1,2	Flat washer Ø16xØ6x10.2	12	12	24	24		
	Q262040	Arandela muelle A-6	Spring washer A-6	12	12	24	24		
	Q162040	Tuerca hexagonal M-6	Hexagonal nut M-6	12	12	24	24		
5	Z510811	Bandeja retenedor "B"	Retaining plate "B"	1	1	2	2		
	Q012042	Tornillo hexagonal M-6x15	Hexagonal screw M-6x15	4	4	8	8		
	Q302022	Arandela plana Ø16xØ6x1,2	Flat washer Ø16xØ6x10.2	4	4	8	8		
	Q262040	Arandela muelle A-6	Spring washer A-6	4	4	8	8		
	Q162040	Tuerca hexagonal M-6	Hexagonal nut M-6	4	4	8	8		
6	Z510812	Bandeja retenedor "A"	Retaining plate "A"	1	1	1	1		
	Q012042	Tornillo hexagonal M-6x15	Hexagonal screw M-6x15	4	4	8	8		
	Q302022	Arandela plana Ø16xØ6x1,2	Flat washer Ø16xØ6x10.2	4	4	8	8		
	Q262040	Arandela muelle A-6	Spring washer A-6	4	4	8	8		
	Q162040	Tuerca hexagonal M-6	Hexagonal nut M-6	4	4	8	8		
7	Z276429	Cortina interior completa	Complete inner curtain	2	2	3	3		
8	Z510344	Sujeción cortina	Curtain fastening	2	2	3	3		

Зип Общепит

vsezip.ru

ZONA

+7(812)987-08-81

MOD.		LAVAVAJILLAS DE CINTA		ZONA		MODULO DE LAVADO (I			
ITEM	CODIGO	DENOMINACION	TEXTO	2700 I	2700 D	4000 I	4000 D		
	Q232040	Arandela plana A-6	Flat washer A-6	4	4	6	6		
	Q262040	Arandela muelle A-6	Spring washer A-6	4	4	6	6		
	Q162040	Tuerca hexagonal M-6	Hexagonal nut M-6	4	4	6	6		
9	Z510318	Amarre cuba lavado	Washing drum support	4	4	8	8		
	Q012042	Tornillo hexagonal M-6x15	Hexagonal screw M-6x15	8	8	16	16		
	Q302022	Arandela plana Ø16xØ6x1,2	Flat washer Ø16xØ6x10.2	24	24	48	48		
	Q262040	Arandela muelle A-6	Spring washer A-6	16	16	32	32		
	Q162040	Tuerca hexagonal M-6	Hexagonal nut M-6	16	16	32	32		
10	Z510333	Perfil anterior izquierdo	Front left profile	1	2	3	1		
s/n	Z510334	Perfil anterior derecho	Front right profile	2	1	1	3		
11	Z510332	Perfil inferior	Lower profile	3	3	4	4		
12	Z510813	Protector	Protector	2	2	3	3		
	Q262040	Arandela muelle A-6	Spring washer A-6	4	4	6	6		
	Q162040	Tuerca hexagonal M-6	Hexagonal nut M-6	4	4	6	6		
13	Z510336	Perfil posterior izquierdo	Rear left profile	1	2	3	1		
s/n	Z510335	Perfil posterior derecho	Rear right profile	2	1	1	3		
14	Z510337	Perfil superior izquierdo	Upper left profile	1	2	3	1		
s/n	Z510338	Perfil superior derecho	Upper right profile	2	1	1	3		
15	Z512927	Panel posterior lavado izquierdo	Left wash rear panel	1	-	-	-		
15	Z512926	Panel posterior lavado derecho	Right wash rear panel	-	1	-	-		
15	Z512930	Panel poster. lavado central decho.	Rear panel. right centre wash	-	-	1	1		
15	Z512931	Panel posterlor lavado central	Rear panel centre wash	-	-	-	-		
15	Z512933	Panel poster. prelavado izquierdo	Rear panel. Left pre-wash	-	-	1	-		
15	Z512932	Panel poster. prelavado derecho	Rear panel. Right pre-wash	-	-	-	1		
	Q152004	Tornillo aplastado M-5x13	Screw M-5x13	2	2	4	4		
	Q221342	Remache hexagonal M-5	Hexagonal rivet M-5	2	2	4	4		
16	Z512963	Soporte panel posterior	Rear panel support	2	2	4	4		
	Q302022	Arandela plana Ø16xØ6x1,2	Flat washer Ø16xØ6x10.2	4	4	8	8		
	Q262040	Arandela muelle A-6	Spring washer A-6	4	4	8	8		

Зип Ощепит

vsezip.ru

ZONA

MODULO DE LAVADO (

MOD.

LAVAVAJILLAS DE CINTA

+7(812)987-08-81

ITEM	CODIGO	DENOMINACION	TEXTO	2700 I	2700 D	4000 I	4000 D
	Q162040	Tuerca hexagonal M-6	Hexagonal nut M-6	4	4	8	8
17	Z510508	Sujeción resorte	Rivet support	2	2	4	4
	Q232040	Arandela plana A-6	Flat washer A-6	4	4	8	8
	Q262030	Arandela muelle A-5	Spring washer A-5	4	4	8	8
	Q212031	Tuerca sombrerete M-5	Cowl nut M-5	4	4	8	8
18	Z270513	Resorte fuerza constante	Constant force spring	2	2	4	4
	Q152004	Tornillo aplastado M-5x13	Screw M-5x13	2	2	4	4
	Q232040	Arandela plana A-6	Flat washer A-6	2	2	4	4
	Q262030	Arandela muelle A-5	Spring washer A-5	2	2	4	4
	Q212031	Tuerca sombrerete M-5	Cowl nut M-5	2	2	4	4
19	Q352001	Pasador de aletas Ø2x15	Cotter pin Ø2x15	4	4	8	8
20	Z270514	Eje resorte	Spindle spring	2	2	4	4
21	Z510514	Soporte resorte	Spring support	2	2	4	4
	Q232040	Arandela plana A-6	Flat washer A-6	4	4	8	8
	Q262030	Arandela muelle A-5	Spring washer A-5	4	4	8	8
	Q212031	Tuerca sombrerete M-5	Cowl nut M-5	4	4	8	8
22	Z270512	Encaje resorte puerta	Door socket spring	4	4	8	8
23	Z270531	Sujeción puerta	Door fastening	1	1	2	2
	Q152047	Tornillo cilíndrico con cuello M-5	Cylindrical screw with neck M-5	2	2	4	4
	Q302022	Arandela plana Ø16xØ6x1,2	Flat washer Ø16xØ6x10.2	2	2	4	4
	Q262030	Arandela muelle A-5	Spring washer A-5	2	2	4	4
	Q212031	Tuerca sombrerete M-5	Cowl nut M-5	2	2	4	4
24	Z510500	Puerta lavado completa	Complete wash door	1	1	2	2
25	Z200506	Imán puerta	Door magnet	1	1	2	2
26	Z200550	Asa puerta completa	Complete door handle	1	1	2	2
27	Z510300	Caja-cuba lavado soldada	Welded wash box-tub	1	1	2	2
28	Z510308	Suplemento caja lavado completo	Complete wash box supplement	1	1	2	2
	Q302022	Arandela plana Ø16xØ6x1,2	Flat washer Ø16xØ6x10.2	4	4	8	8
	Q262040	Arandela muelle A-6	Spring washer A-6	4	4	8	8

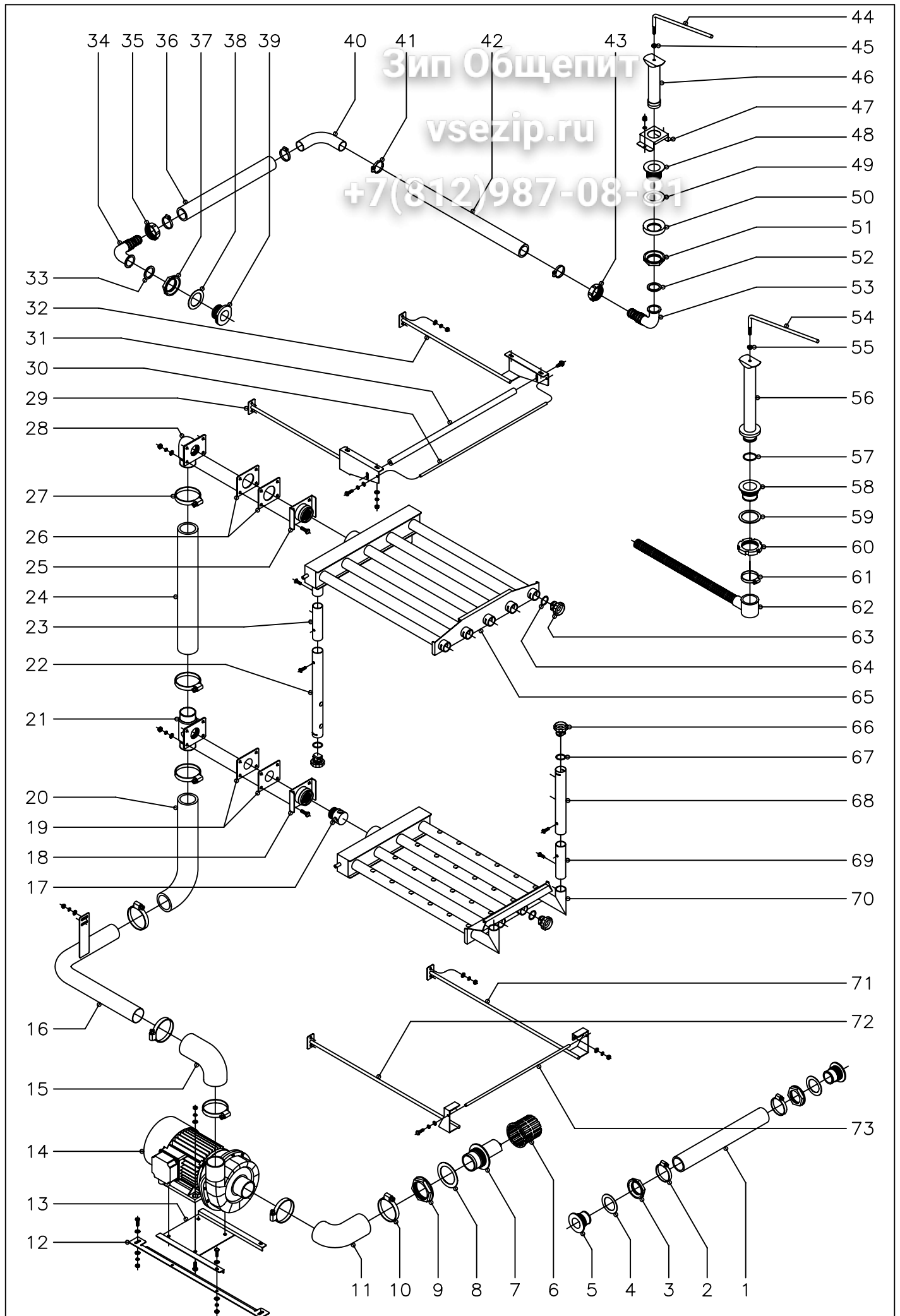

N plano C-1548	Firma 	Fecha 7-2004	Aparato LAVAVAJILLAS DE CINTA PARTE FUNCIONAL LAVADO	Lamina 4	Fagor Industrial S.Coop. FAGOR
					Onate

Зип Общепит

vsezip.ru

ZONA

+7(812)987-08-81

MOD.		LAVAVAJILLAS DE CINTA		ZONA		MODULO DE LAVADO (Part			
ITEM	CODIGO	DENOMINACION	TEXTO	2700 I	2700 D	4000 I	4000 D		
1	Z330906	Manguera comunicación	Connection pipe	-	-	1	1		
2	Q881324	Abrazadera 50 -70	Clamp 50-70	-	-	2	2		
3	Z702101	Tuerca R-1 1/2"	Nut R-1 1/2"	-	-	2	2		
4	Q307009	Arandela junta Ø70xØ48x1,5	Joint washer Ø70xØ48x10.5	-	-	2	2		
5	Z330901	Pasamuros comunicación	Connection wire protection	-	-	2	2		
6	Z310906	Filtro aspiración	Extractor filter	1	1	2	2		
7	Z310901	Pasamuros aspiración	Extractor wire protection	1	1	2	2		
8	Z310902	Arandela junta Ø92xØ66x2	Joint washer Ø92xØ66x2	1	1	2	2		
9	Z310903	Tuerca pasamuros M-65X2,5	Wire protection nut M-65X20.5	1	1	2	2		
10	Q881326	Abrazadera 70 - 90	Clamp 70 - 90	3	3	6	6		
11	Z310904	Codo aspiración	Extractor elbow	1	1	2	2		
12	Z511003	Sujeción motobomba lavado	Wash motor pump fastener	2	2	4	4		
	Q012042	Tornillo hexagonal M-6x15	Hexagonal screw M-6x15	4	4	8	8		
	Q302022	Arandela plana Ø16xØ6x1,2	Flat washer Ø16xØ6x10.2	8	8	16	16		
	Q262040	Arandela muelle A-6	Spring washer A-6	4	4	8	8		
	Q162040	Tuerca hexagonal M-6	Hexagonal nut M-6	4	4	8	8		
13	Z511002	Soporte motobomba	Motor pump support	1	1	2	2		
	Q012042	Tornillo hexagonal M-6x15	Hexagonal screw M-6x15	2	2	4	4		
	Q302022	Arandela plana Ø16xØ6x1,2	Flat washer Ø16xØ6x10.2	4	4	8	8		
	Q262040	Arandela muelle A-6	Spring washer A-6	2	2	4	4		
	Q162040	Tuerca hexagonal M-6	Hexagonal nut M-6	2	2	4	4		
14	Z511001	Motobomba (220/380, 50 Hz.)	Motor pump (220/380, 50 Hz.)	1	1	2	2		
14	Z514101	Motobomba (220/380, 60 Hz.)	Motor pump (220/380, 60 Hz.)	1	1	2	2		
	Q012055	Tornillo hexagonal M-8x30	Hexagonal screw M-8x30	4	4	8	8		
	Q232050	Arandela plana A-8	Flat washer A-8	8	8	16	16		
	Q262050	Arandela muelle A-8	Spring washer A-8	4	4	8	8		
	Q162050	Tuerca hexagonal M-8	Hexagonal nut M-8	4	4	8	8		
15	Z510902	Codo impulsión	Impulse elbow	1	1	2	2		
16	Z510910	Codo empalme impulsión comp.	Complete impulse elbow joint	1	1	2	2		

Зип Общепит

vsezip.ru

+7(812)987-08-81

MOD.		LAVAVAJILLAS DE CINTA		ZONA		MODULO DE LAVADO (Parte			
ITEM	CODIGO	DENOMINACION	TEXTO	2700 I	2700 D	4000 I	4000 D		
	Q302022	Arandela plana Ø16xØ6x1,2	Flat washer Ø16xØ6x10.2	2	2	4	4		
	Q262040	Arandela muelle A-6	Spring washer A-6	2	2	4	4		
	Q162040	Tuerca hexagonal M-6	Hexagonal nut M-6	2	2	4	4		
17	Z310753	Reducción caudal lavado	Wash flow reduction	1	1	2	2		
18	Z510701	Soporte suplemento soldado	Welded supplement support	1	1	2	2		
	Q012055	Tornillo hexagonal M-8x30	Hexagonal screw M-8x30	4	4	8	8		
19	Z510908	Junta pasamuros	Wire protection joint	2	2	4	4		
20	Z510904	Empalme inferior impulsión	Lower impulse joint	1	1	2	2		
21	Z510905	Pasamuros lavado inferior	Lower wash wire protection	1	1	2	2		
	Q232050	Arandela plana A-8	Flat washer A-8	4	4	8	8		
	Q262050	Arandela muelle A-8	Spring washer A-8	4	4	8	8		
	Q162050	Tuerca hexagonal M-8	Hexagonal nut M-8	4	4	8	8		
22	Z510725	Rama lavado lateral superior	Upper side wash branch	2	2	4	4		
23	Z510728	Suplemento rama lateral	Side branch supplement	2	2	4	4		
	Q152004	Tornillo aplastado M-5x13	Screw M-5x13	4	4	8	8		
24	Z510906	Empalme superior impulsión	Upper impulse joint	1	1	2	2		
25	Z510701	Soporte suplemento soldado	Welded supplement support	1	1	2	2		
	Q012055	Tornillo hexagonal M-8x30	Hexagonal screw M-8x30	4	4	8	8		
26	Z510908	Junta pasamuros	Wire protection joint	2	2	4	4		
27	Q881326	Abrazadera 70 - 90	Clamp 70 - 90	5	5	10	10		
28	Z510907	Pasamuros lavado superior	Upper wash wire protection	1	1	2	2		
	Q232050	Arandela plana A-8	Flat washer A-8	4	4	8	8		
	Q262050	Arandela muelle A-8	Spring washer A-8	4	4	8	8		
	Q162050	Tuerca hexagonal M-8	Hexagonal nut M-8	4	4	8	8		
29	Z510704	Soporte superior izquierdo comp.	Complete upper left support	1	1	2	2		
	Q302022	Arandela plana Ø16xØ6x1,2	Flat washer Ø16xØ6x10.2	2	2	4	4		
	Q262040	Arandela muelle A-6	Spring washer A-6	2	2	4	4		
	Q162040	Tuerca hexagonal M-6	Hexagonal nut M-6	2	2	4	4		
30	Z510708	Varilla sujeción superior	Upper fastening rod	1	1	2	2		

Зип Общепит

vsezip.ru

ZONA

+7(812)987-08-81

MOD.		LAVAVAJILLAS DE CINTA	ZONA		MODULO DE LAVADO (Par			
ITEM	CODIGO	DENOMINACION	TEXTO	2700 I	2700 D	4000 I	4000 D	
	Q012021	Tornillo hexagonal M-4x10	Hexagonal screw M-4x10	2	2	4	4	
	Q261020	Arandela muelle A-4	Spring washer A-4	2	2	4	4	
	Q232020	Arandela plana A-4	Flat washer A-4	2	2	4	4	
31	Z510717	Contrapeso	Counter balance	1	1	2	2	
	Q152046	Tornillo hexagonal con cuello M-6	Hexagonal screw with neck M-6	2	2	4	4	
32	Z510709	Soporte superior derecho comp.	Complete upper right support.	1	1	2	2	
	Q302022	Arandela plana Ø16xØ6x1,2	Flat washer Ø16xØ6x10.2	2	2	4	4	
	Q262040	Arandela muelle A-6	Spring washer A-6	2	2	4	4	
	Q162040	Tuerca hexagonal M-6	Hexagonal nut M-6	2	2	4	4	
33	Q307027	Arandela junta Ø45xØ35x2	Joint washer Ø45xØ35x2	1	1	1	1	
34	Z602101	Codo desagüe	Drainage elbow	1	1	1	1	
35	Z602102	Tuerca	Nut	1	1	1	1	
36	Z310912	Manguera comunicación	Connection pipe	1	1	1	1	
37	Z702101	Tuerca R-1 1/2"	Nut R-1 1/2"	1	1	1	1	
38	Q307009	Arandela junta Ø70xØ48x1,5	Joint washer Ø70xØ48x10.5	1	1	1	1	
39	Z510931	Pasamuros	Wire protection	1	1	1	1	
40	Z310932	Codo empalme	Elbow joint	1	1	1	1	
41	Q881307	Abrazadera 40 - 60	Clamp 40 - 60	4	4	4	4	
42	Z510934	Manguera comunicación preacla.	Prerinse connection pipe	1	1	1	1	
43	Z602102	Tuerca	Nut	1	1	1	1	
44	Z510924	Asa aliviadero preaclarado	Prerinse overflow handle	1	1	1	1	
45	Q162050	Tuerca hexagonal M-8	Hexagonal nut M-8	1	1	1	1	
46	Z510921	Aliviadero preaclarado soldado	Welded prerinse overflow	1	1	1	1	
47	Z510941	Guía aliviadero preaclarado	Prerinse overflow guide	1	1	1	1	
	Q262040	Arandela muelle A-6	Spring washer A-6	2	2	2	2	
	Q212040	Tuerca sombrerete M-6	Cowl nut M-6	2	2	2	2	
48	Z102104	Válvula desagüe	Drainage valve	1	1	1	1	
49	Q307009	Arandela junta Ø70xØ48x1,5	Joint washer Ø70xØ48x10.5	1	1	1	1	
50	Q307026	Junta especial	Special joint	1	1	1	1	

Зип Общепит

vsezip.ru

ZONA

MODULO DE LAVADO (Par

MOD.

LAVAVAJILLAS DE CINTA

+7(812)987-08-81

ITEM	CODIGO	DENOMINACION	TEXTO	2700 I	2700 D	4000 I	4000 D
51	Z702101	Tuerca rosca 1 1/2"	Nut thread 1 1/2"	1	1	1	1
52	Q307027	Arandela junta Ø45xØ35x2	Joint washer Ø45xØ35x2	1	1	1	1
53	Z602101	Codo desagüe	Drainage elbow	1	1	1	1
54	Z510916	Asa aliviadero lavado	Wash overflow handle	1	1	1	1
55	Q162050	Tuerca hexagonal M-8	Hexagonal nut M-8	1	1	1	1
56	Z510911	Aliviadero lavado soldado	Welded wash overflow	1	1	1	1
57	Q307051	Junta tórica Ø41,41xØ36,17xØ2,6	"O" ring Ø41,41xØ36,17xØ2,6	1	1	1	1
58	Z710902	Pasamuros desagüe	Drainage wire protection	1	1	1	1
59	Q307059	Arandela junta Ø72xØ56x2	Joint washer Ø72xØ56x2	1	1	1	1
60	Q220001	Tuerca ranurada M-56x2,5	Slotted nut M-56x2,5	1	1	1	1
61	Q881324	Abrazadera 50 - 70	Clamp 50 - 70	1	1	1	1
62	Z200910	Manguera desagüe	Drainage pipe	1	1	1	1
63	Z310721	Tapón cierre	Closure plug	7	7	14	14
64	Q307068	Junta tórica Ø33xØ27xØ3	"O" ring Ø33xØ27xØ3	7	7	14	14
65	Z510719	Distribuidor superior lavado comp.	Complete wash upper distributor	1	1	2	2
66	Z310721	Tapón cierre	Closure plug	4	4	8	8
67	Q307068	Junta tórica Ø33xØ27xØ3	"O" ring Ø33xØ27xØ3	4	4	8	8
68	Z510747	Rama lavado lateral inferior	Lower side wash branch	2	2	4	4
69	Z510728	Suplemento rama lateral	Side branch supplement	2	2	4	4
	Q152004	Tornillo aplastado M-5x13	Screw M-5x13	4	4	8	8
70	Z510739	Distribuidor inferior lavado comp.	Complete wash lower distributor	1	1	2	2
71	Z510715	Soporte inferior derecho completo	Complete lower right support	1	1	2	2
72	Z510711	Soporte inferior izquierdo completo	Complete lower left support	1	1	2	2
	Q302022	Arandela plana Ø16xØ6x1,2	Flat washer Ø16xØ6x1,2	4	4	8	8
	Q262040	Arandela muelle A-6	Spring washer A-6	4	4	8	8
	Q162040	Tuerca hexagonal M-6	Hexagonal nut M-6	4	4	8	8
73	Z510714	Varilla sujeción inferior	Lower fastening rod	1	1	2	2
	Q012021	Tornillo hexagonal M-4x10	Hexagonal screw M-4x10	2	2	4	4
	Q261020	Arandela muelle A-4	Spring washer A-4	2	2	4	4
	Q232020	Arandela plana A-4	Flat washer A-4	2	2	4	4

Зип Общепит

vsezip.ru

+7(812)987-08-81

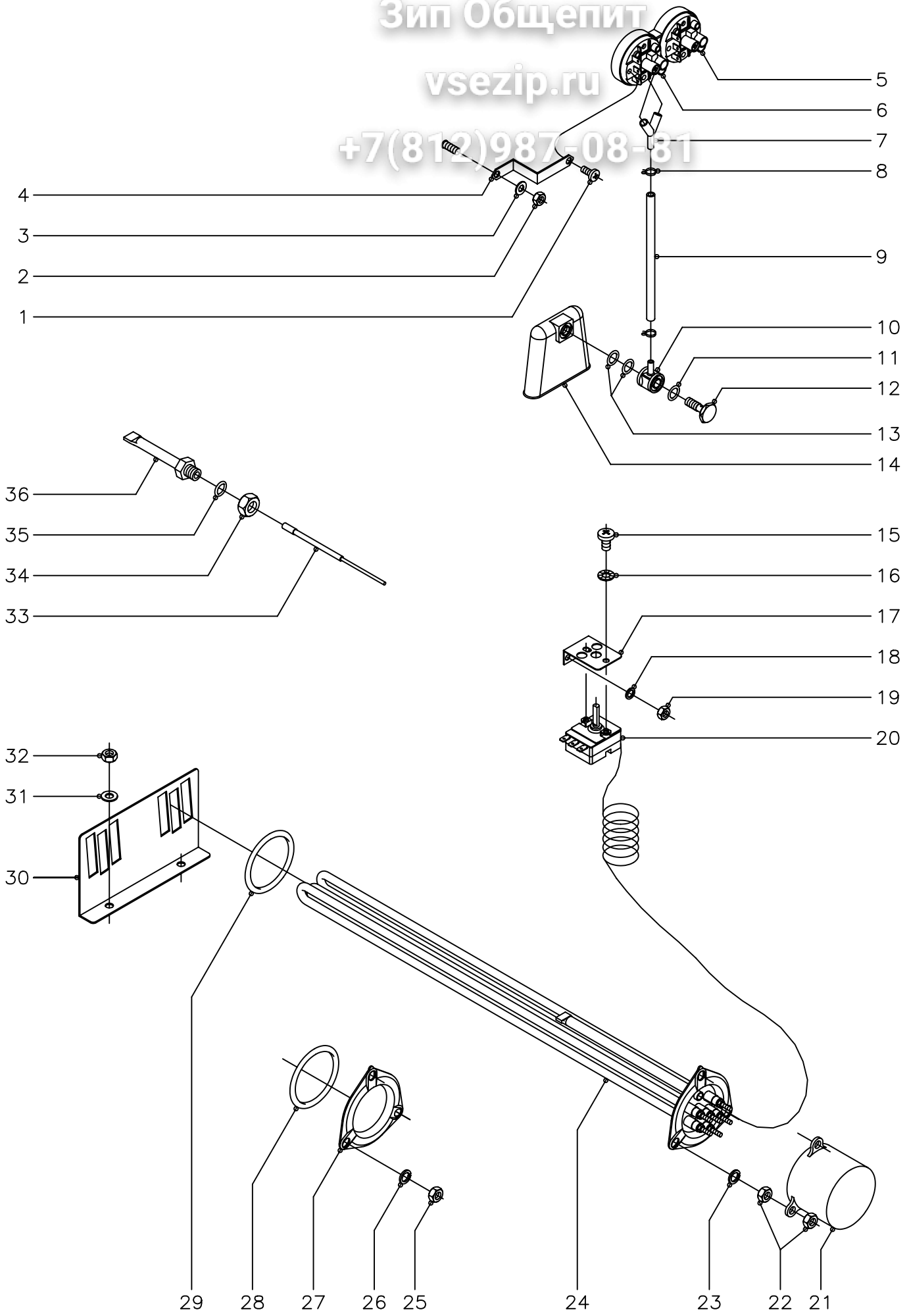

N plano C-1549	Firma 	Fecha 7-2004	Aparato LAVAVAJILLAS DE CINTA NIVELES Y CALENTAMIENTO LAVADO	Lamina 5	Fagor Industrial S.Coop. FAGOR Oñate
-------------------	-----------	-----------------	--	-------------	--

Зип Общепит

vsezip.ru

ZONA

MODULO DE LAVADO (Niveles y

MOD.

LAVAVAJILLAS DE CINTA

+7(812)987-08-81

ITEM	CODIGO	DENOMINACION	TEXTO	2700 I	2700 D	4000 I	4000 D
1	Q082032	Tornillo alomado BZ-3,5x9,5	Curved screw BZ-3.5x90.5	1	1	2	2
2	Q162040	Tuerca hexagonal M-6	Hexagonal nut M-6	1	1	2	2
3	Q232040	Arandela plana A-6	Flat washer A-6	1	1	2	2
4	Z602923	Soporte presostato	Pressostat support	1	1	2	2
5	Z103074	Presostato simple	Simple pressostat	1	1	2	2
6	Z513001	Presostato simple	Simple pressostat	1	1	2	2
7	Z103077	Racord en "Y"	"Y" joint	1	1	2	2
8	P102154	Brida elástica	Elastic yoke	2	2	4	4
9	3702400	Tubo de goma Ø 8x4x240	Rubber pipe Ø 8x4x240	1	1	2	2
10	Z203012	Empalme presostato	Pressostat joint	1	1	2	2
11	Q307003	Junta tórica Ø16,01xØ10,77xØ2,62	"O" ring Ø16,01xØ10,77xØ2.62	1	1	2	2
12	Z203013	Tornillo presostato	Pressostat screw	1	1	2	2
13	Q307003	Junta tórica Ø16,01xØ10,77xØ2,62	"O" ring Ø16,01xØ10,77xØ2.62	2	2	4	4
14	Z203011	Cámara presostato	Pressostat chamber	1	1	2	2
15	Q152024	Tornillo avellanado M-4x8	Countersunk screw M-4x8	2	2	2	2
16	Q242020	Arandela abanico A-4	Fan shaped washer A-4	2	2	2	2
17	Z850111	Soporte termostato	Thermostat support	1	1	1	1
18	Q232040	Arandela plana A-6	Flat washer A-6	2	2	2	2
19	Q162040	Tuerca hexagonal M-6	Hexagonal nut M-6	2	2	2	2
20	Z203014	Termostato	Thermostat	1	1	1	1
21	Z101723	Caperuza resistencia	Resistor cap	2	2	2	2
22	Q163140	Tuerca hexagonal M-6 LATÓN	Brass hexagonal nut M-6	12	12	12	12
23	Q262040	Arandela muelle A-6	Spring washer A-6	6	6	6	6
24	Z121741	Resistencia 230 V., 9.600 W.	Resistance 230 V., 9,600 W.	2	2	2	2
24	Z129502	Resistencia 230 V., 12.000 W.	Resistance 230 V., 12,000 W.	-	-	-	-
25	Q163040	Tuerca hexagonal M-6 LATÓN	Brass hexagonal nut M-6	-	-	6	6
26	Q262040	Arandela muelle A-6	Spring washer A-6	-	-	6	6
27	Z310703	Brida ciega	Blind yoke	-	-	2	2
28	Q307044	Junta tórica Ø67,18xØ56,52xØ5,30	"O" ring Ø67,18xØ56,52xØ5.30	-	-	2	2

Зип Общепит

vsezip.ru

+7(812)987-08-81

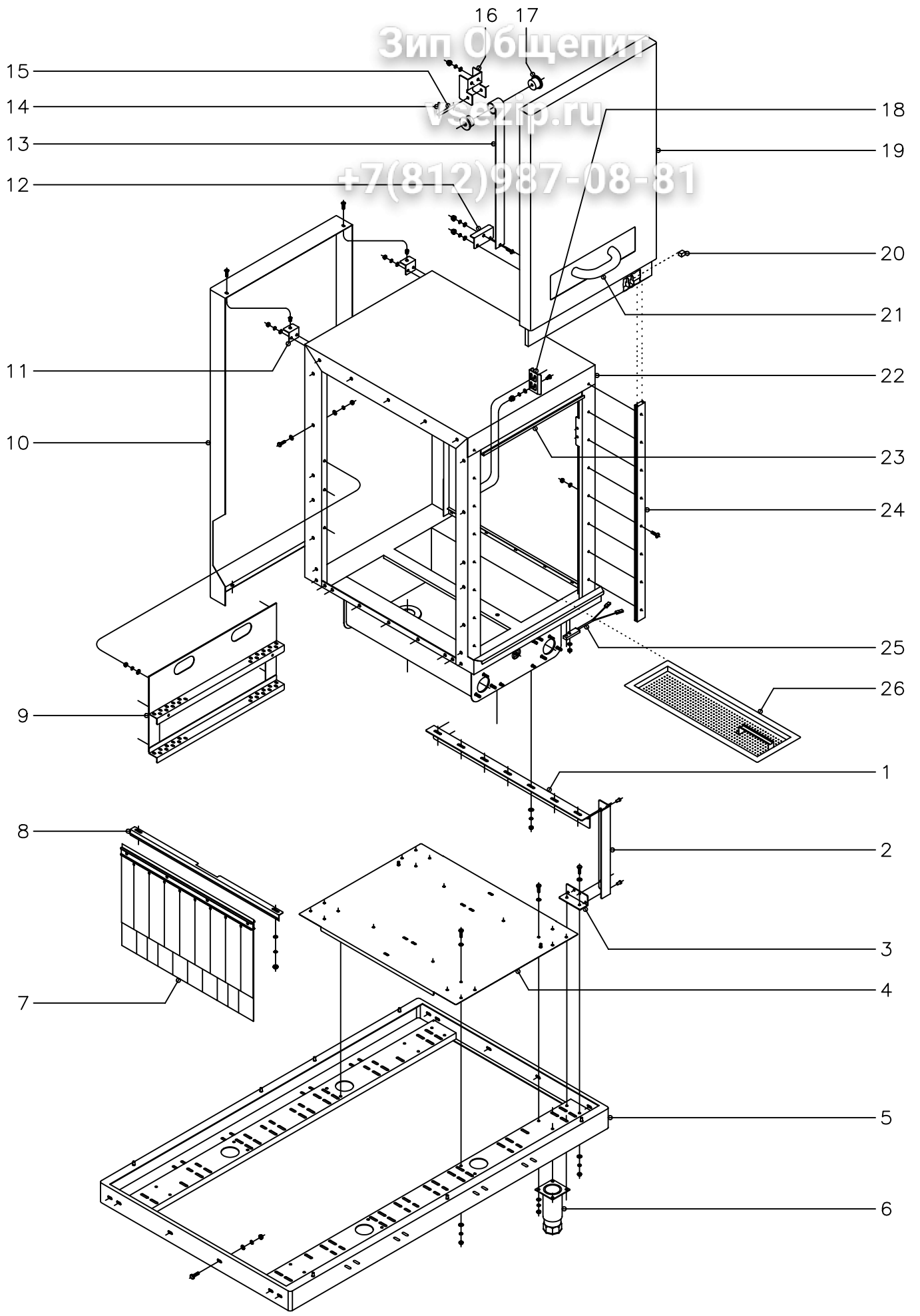

N plano C-1550	Firma 	Fecha 7-2004	Aparato LAVAVAJILLAS DE CINTA MODULO DE PREACLARADO (Mueble)	Lamina 6	Fagor Industrial S.Coop. FAGOR
-------------------	-----------	-----------------	--	-------------	---------------------------------------

Зип Общепит

vsezip.ru

ZONA

MODULO DE PREACLAR

MOD.

LAVAVAJILLAS DE CINTA

+7(812)987-08-81

ITEM	CODIGO	DENOMINACION	TEXTO	2700 I	2700 D	4000 I	4000 D
1	Z510113	Larguero soporte	Crossbar support	1	1	1	1
	Q302022	Arandela plana Ø16xØ6x1,2	Flat washer Ø16xØ6x10.2	7	7	7	7
	Q262040	Arandela muelle A-6	Spring washer A-6	7	7	7	7
	Q162040	Tuerca hexagonal M-6	Hexagonal nut M-6	7	7	7	7
2	Z510114	Poste	Post	2	2	2	2
	Q411304	Remache avibulb Ø4,8	Avibulb rivet Ø40.8	8	8	8	8
3	Z510112	Base soporte	Support base	2	2	2	2
	Q012043	Tornillo hexagonal M-6x20	Hexagonal screw M-6x20	4	4	4	4
	Q302022	Arandela plana Ø16xØ6x1,2	Flat washer Ø16xØ6x10.2	8	8	8	8
	Q262040	Arandela muelle A-6	Spring washer A-6	4	4	4	4
	Q162040	Tuerca hexagonal M-6	Hexagonal nut M-6	4	4	4	4
4	Z510104	Panel transversal preaclarado com	Complete prerinse transverse panel	1	1	1	1
	Q012043	Tornillo hexagonal M-6x20	Hexagonal screw M-6x20	4	4	4	4
	Q302022	Arandela plana Ø16xØ6x1,2	Flat washer Ø16xØ6x10.2	8	8	8	8
	Q262040	Arandela muelle A-6	Spring washer A-6	4	4	4	4
	Q162040	Tuerca hexagonal M-6	Hexagonal nut M-6	4	4	4	4
5	Z510101	Armazón soldado (Lavad.-aclarad.)	Welded framework (Wash-rinse)	1	1	1	1
	Q012053	Tornillo hexagonal M-8x20	Hexagonal screw M-8x20	8	8	12	12
	Q232050	Arandela plana A-8	Flat washer A-8	8	8	12	12
	Q262050	Arandela muelle A-8	Spring washer A-8	8	8	12	12
	Q162050	Tuerca hexagonal M-8	Hexagonal nut M-8	8	8	12	12
6	X260151	Pata regulable	Ajustable leg	4	4	8	8
	Q012043	Tornillo hexagonal M-6x20	Hexagonal screw M-6x20	16	16	32	32
	Q302022	Arandela plana Ø16xØ6x1,2	Flat washer Ø16xØ6x10.2	32	32	64	64
	Q262040	Arandela muelle A-6	Spring washer A-6	16	16	32	32
	Q162040	Tuerca hexagonal M-6	Hexagonal nut M-6	16	16	32	32
7	Z276429	Cortina interior completa	Complete inner curtain	1	1	1	1
8	Z510344	Sujeción cortina	Curtain fastening	1	1	1	1
	Q232040	Arandela plana A-6	Flat washer A-6	2	2	2	2

MOD.		LAVAVAJILLAS DE CINTA	ZONA	MODULO DE PREACLARADO			
ITEM	CODIGO	DENOMINACION	TEXTO	2700 I	2700 D	4000 I	4000 D
	Q262040	Arandela muelle A-6	Spring washer A-6	2	2	2	2
	Q162040	Tuerca hexagonal M-6	Hexagonal nut M-6	2	2	2	2
9	Z511811	Guía preaclorado completa	Complete prerinse guide	2	2	2	2
	Q302022	Arandela plana Ø16xØ6x1,2	Flat washer Ø16xØ6x10.2	12	12	12	12
	Q262040	Arandela muelle A-6	Spring washer A-6	12	12	12	12
	Q162040	Tuerca hexagonal M-6	Hexagonal nut M-6	12	12	12	12
10	Z512929	Panel posterior preaclorado izdo.	Left prerinse rear panel	1	-	1	-
10	Z512928	Panel posterior preaclorado decho.	Right prerinse rear panel	-	1	-	1
	Q152004	Tornillo aplastado M-5x13	Screw M-5x13	2	2	2	2
	Q221342	Remache hexagonal M-5	Hexagonal rivet M-5	2	2	2	2
11	Z512963	Soporte panel posterior	Rear panel support	2	2	2	2
	Q302022	Arandela plana Ø16xØ6x1,2	Flat washer Ø16xØ6x10.2	4	4	4	4
	Q262040	Arandela muelle A-6	Spring washer A-6	4	4	4	4
	Q162040	Tuerca hexagonal M-6	Hexagonal nut M-6	4	4	4	4
12	Z510508	Sujeción resorte	Spring support	1	1	1	1
	Q232040	Arandela plana A-6	Flat washer A-6	2	2	2	2
	Q262030	Arandela muelle A-5	Spring washer A-5	2	2	2	2
	Q212031	Tuerca sombrerete M-5	Cowl nut M-5	2	2	2	2
13	Z270513	Resorte fuerza constante	Constant force spring	1	1	1	1
	Q152004	Tornillo aplastado M-5x13	Screw M-5x13	1	1	1	1
	Q232040	Arandela plana A-6	Flat washer A-6	1	1	1	1
	Q262030	Arandela muelle A-5	Spring washer A-5	1	1	1	1
	Q212031	Tuerca sombrerete M-5	Cowl nut M-5	1	1	1	1
14	Q352001	Pasador de aletas Ø2x15	Cotter pin Ø2x15	2	2	2	2
15	Z270514	Eje resorte	Spindle spring	1	1	1	1
16	Z510514	Soporte resorte	Spring support	1	1	1	1
	Q232040	Arandela plana A-6	Flat washer A-6	2	2	2	2
	Q262030	Arandela muelle A-5	Spring washer A-5	2	2	2	2
	Q212031	Tuerca sombrerete M-5	Cowl nut M-5	2	2	2	2

Зип Ощепит

vsezip.ru

ZONA

MODULO DE PREACLARA

MOD.

LAVAVAJILLAS DE CINTA

+7(812)987-08-81

ITEM	CODIGO	DENOMINACION	TEXTO	2700 I	2700 D	4000 I	4000 D
17	Z270512	Encaje resorte puerta	Door socket spring	2	2	2	2
18	Z270531	Sujeción puerta	Door fastening	1	1	1	1
	Q152047	Tornillo cilíndrico con cuello M-5	Cylindrical screw with neck M-5	2	2	2	2
	Q302022	Arandela plana Ø16xØ6x1,2	Flat washer Ø16xØ6x10.2	2	2	2	2
	Q262030	Arandela muelle A-5	Spring washer A-5	2	2	2	2
	Q212031	Tuerca sombrerete M-5	Cowl nut M-5	2	2	2	2
19	Z510520	Puerta preaclarado completa	Complete prerinse door	1	1	1	1
20	Z200506	Imán puerta	Door magnet	1	1	1	1
21	Z400540	Asa puerta completa	Complete door handle	1	1	1	1
22	Z511801	Caja-cuba preaclarado completa	Complete prerinse box-tub	1	1	1	1
23	Z511808	Suplemento caja preaclarado com.	Complete prerinse box supplement	1	1	1	1
	Q302022	Arandela plana Ø16xØ6x1,2	Flat washer Ø16xØ6x10.2	3	3	3	3
	Q262040	Arandela muelle A-6	Spring washer A-6	3	3	3	3
	Q162040	Tuerca hexagonal M-6	Hexagonal nut M-6	3	3	3	3
24	Z510331	Guía puerta	Door guide	2	2	2	2
	Q152045	Tornillo amarre M-6x25	Anchoring screw M-6x25	16	16	16	16
	Q232040	Arandela plana A-6	Flat washer A-6	16	16	16	16
	Q222012	Tuerca autoblocante M-6	Autolock nut M-6	16	16	16	16
25	Z100522	Interruptor magnético (puerta)	Magnetic switch (door)	1	1	1	1
	Q242020	Arandela abanico A-4	Fan shaped washer A-4	2	2	2	2
	Q162020	Tuerca hexagonal M-4	Hexagonal nut M-4	2	2	2	2
26	Z510808	Bandeja preaclarado completa	Complete prerinse plate	2	2	2	2

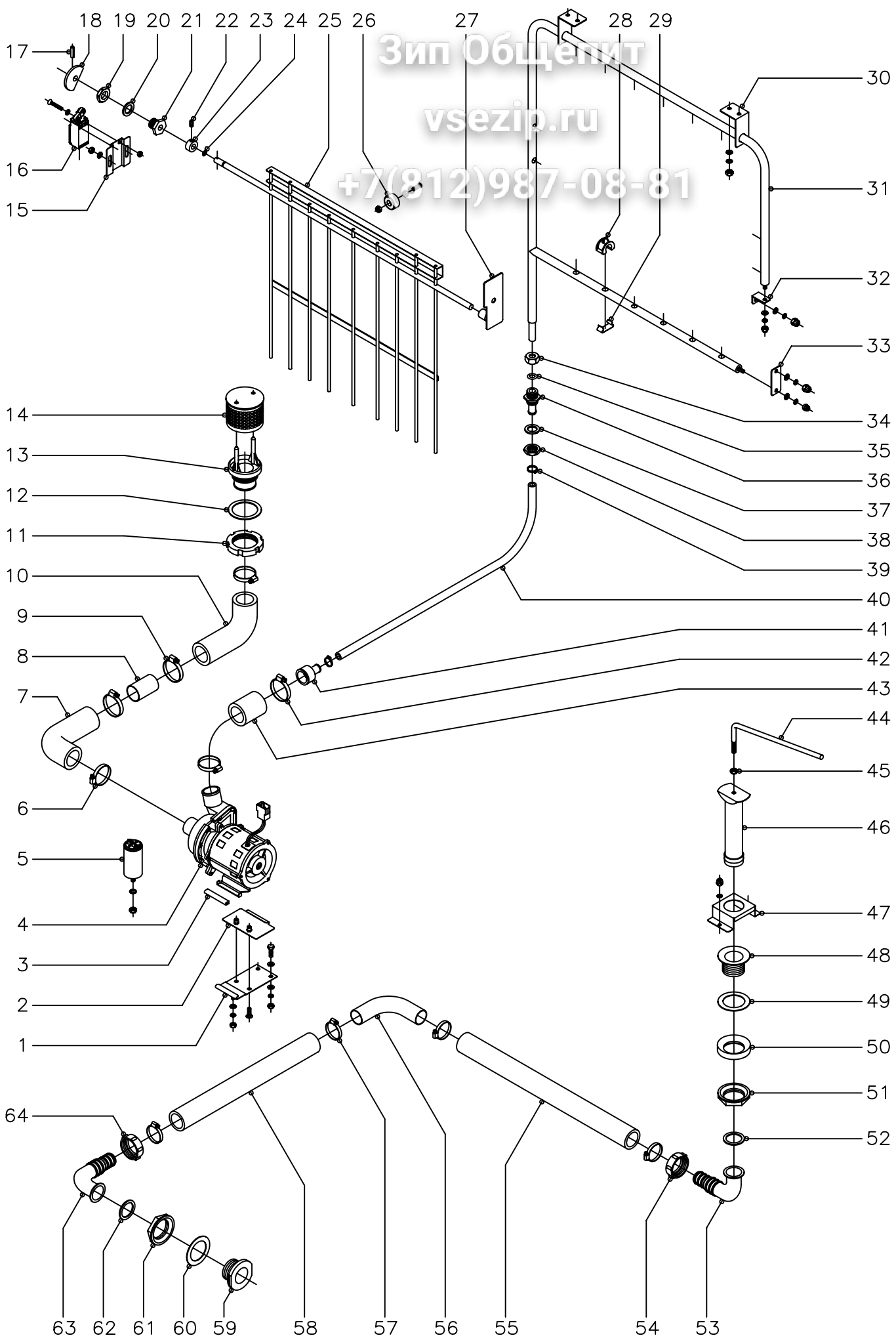

N plano C-1551	Firma 	Fecha 7-2004	Aparato LAVAVAJILLAS DE CINTA PARTE FUNCIONAL PREACLARADO	Lamina 7	Fagor Industrial S.Coop. FAGOR  Onate
-------------------	--	-----------------	---	-------------	--

MOD.		LAVAVAJILLAS DE CINTA	ZONA		MODULO DE PREACLARADO (I			
ITEM	CODIGO	DENOMINACION	TEXTO	2700 I	2700 D	4000 I	4000 D	
1	Z162315	Soporte motobomba completo	Complete motor pump support	1	1	1	1	
	Q012042	Tornillo hexagonal M-6x15	Hexagonal screw M-6x15	2	2	2	2	
	Q302022	Arandela plana Ø16xØ6x1,2	Flat washer Ø16xØ6x10.2	5	5	5	5	
	Q262040	Arandela muelle A-6	Spring washer A-6	3	3	3	3	
	Q162040	Tuerca hexagonal M-6	Hexagonal nut M-6	3	3	3	3	
2	Z162313	Amarre motobomba completo	Complete motor pump anchoring	1	1	1	1	
	Q152004	Tornillo aplastado M-5X13	Screw M-5x13	2	2	2	2	
3	Z401007	Perfil soporte motobomba	Motor pump support profile	2	2	2	2	
4	Z401001	Motobomba preaclarado	Prerinse motor pump	1	1	1	1	
5	V817100	Condensador 6 Mf.	Condenser 6 Mf.	1	1	1	1	
	Q261050	Arandela muelle A-8	Spring washer A-8	1	1	1	1	
	Q162050	Tuerca hexagonal M-8	Hexagonal nut M-8	1	1	1	1	
6	Q881324	Abrazadera 50 - 70	Clamp 50 - 70	2	2	2	2	
7	Z510932	Conducto aspiración preaclarado	Prerinse extraction pipe	1	1	1	1	
8	Z510933	Casquillo preaclarado	Prerinse bush	1	1	1	1	
9	Q881324	Abrazadera 50 - 70	Clamp 50 - 70	2	2	2	2	
10	Z510932	Conducto aspiración preaclarado	Prerinse extraction pipe	1	1	1	1	
11	Q228005	Tuerca ranurada M-49X2,5	Slotted nut M-49x20.5	1	1	1	1	
12	Q307059	Arandela junta Ø72xØ56x2	Joint washer Ø72xØ56x2	1	1	1	1	
13	Z600905	Pasamuros aspiración	Extractor wire protection	1	1	1	1	
14	Z600906	Filtro aspiración	Extractor filter	1	1	1	1	
15	Z511231	Soporte micro aclarado	Micro rinse support	1	1	1	1	
	Q232040	Arandela plana A-6	Flat washer A-6	2	2	2	2	
	Q222012	Tuerca hexagonal autoblocante M-6	Autolocking hexagonal nut M-6	2	2	2	2	
16	Z513007	Final de carrera (Micro aclarado)	End of run (Micro rinse)	1	1	1	1	
	Q152026	Tornillo avellanado M-4x35	Countersunk screw M-4x35	2	2	2	2	
	Q242020	Arandela abanico A-4	Fan shaped washer A-4	2	2	2	2	
	Q162020	Tuerca hexagonal M-4	Hexagonal nut M-4	2	2	2	2	
17	Q371031	Manguito sujeción Ø3x20	Fastening socket Ø3x20	1	1	1	1	

Зип Общепит

vsezip.ru

ZONA

MODULO DE PREACLARADO (

MOD.

LAVAVAJILLAS DE CINTA

+7(812)987-08-81

ITEM	CODIGO	DENOMINACION	TEXTO	2700 I	2700 D	4000 I	4000 D
18	Z511209	Leva	Cam	1	1	1	1
19	Q223023	Tuerca hexagonal 5/8"	Hexagonal nut 5/8"	1	1	1	1
20	Q307032	Arandela junta Ø32xØ21x3	Joint washer Ø32xØ21x3	1	1	1	1
21	Z511201	Casquillo roscado 5/8"	Threaded bush 5/8"	1	1	1	1
22	Q132041	Varilla roscada M-6x10	Threaded rod M-6x10	1	1	1	1
23	Z511208	Tope eje accionador	Actuator spindle buffer	1	1	1	1
24	Q307070	Junta tórica Ø12,74xØ7,5xØ2,62	"O" ring Ø12,74xØ7,5xØ2,62	1	1	1	1
25	Z511202	Accionador aclarado izquierdo	Left rinse actuator	1	-	1	-
25	Z511221	Accionador aclarado derecho	Right rinse actuator	-	1	-	1
26	Z510342	Tope accionador aclarado	Rinse actuator buffer	1	1	1	1
	Q152013	Perno soldado M-6x30	Welded bolt M-6x30	1	1	1	1
	Q162040	Tuerca hexagonal M-6	Hexagonal nut M-6	1	1	1	1
	Q222012	Tuerca hexagonal autoblocante M-6	Autolocking hexagonal nut M-6	1	1	1	1
27	-	Soporte-casquillo derecho comp.	Complete right bush support.	1	-	1	-
27	-	Soporte-casquillo izquierdo comp.	Complete left bush support.	-	1	-	1
28	Z311831	Tobera preaclarado	Prerinse nozzle	16	16	16	16
29	Z400711	Enganche tobera preaclarado	Prerinse nozzle hook	16	16	16	16
30	Z511925	Amarre superior preaclarado "A"	Upper anchoring prerinse "A"	2	2	2	2
	Q302022	Arandela plana Ø16xØ6x1,2	Flat washer Ø16xØ6x1.2	4	4	4	4
	Q262040	Arandela muelle A-6	Spring washer A-6	4	4	4	4
	Q162040	Tuerca hexagonal M-6	Hexagonal nut M-6	4	4	4	4
31	Z511921	Árbol preaclarado completo	Complete prerinse arbour	1	1	1	1
	Q232040	Arandela plana A-6	Flat washer A-6	2	2	2	2
	Q262030	Arandela muelle A-5	Spring washer A-5	2	2	2	2
	Q212031	Tuerca sombrerete M-5	Cowl nut M-5	2	2	2	2
32	Z511926	Sujeción superior preaclarado "B"	Prerinse upper fastening "B"	1	1	1	1
	Q232040	Arandela plana A-6	Flat washer A-6	1	1	1	1
	Q262040	Arandela muelle A-6	Spring washer A-6	1	1	1	1
	Q212040	Tuerca sombrerete M-6	Cowl nut M-6	1	1	1	1

Зип Общепит

vsezip.ru

ZONA

+7(812)987-08-81

MOD.		LAVAVAJILLAS DE CINTA		MODULO DE PREACLARADO (I			
ITEM	CODIGO	DENOMINACION	TEXTO	2700 I	2700 D	4000 I	4000 D
33	Z511907	Sujeción rama inferior preaclarado	Prerinse lower branch fastening	1	1	1	1
	Q232040	Arandela plana A-6	Flat washer A-6	1	1	1	1
	Q262040	Arandela muelle A-6	Spring washer A-6	1	1	1	1
	Q212040	Tuerca sombrerete M-6	Cowl nut M-6	1	1	1	1
34	Q223108	Tuerca M-24x2,5	Nut M-24x20.5	1	1	1	1
35	Q307063	Junta tórica Ø19,35xØ12,29xØ3,53	"O" ring Ø19,35xØ12,29xØ30.53	1	1	1	1
36	Z281901	Pasamuros aclarado	Rinse wire protection	1	1	1	1
37	Q307032	Arandela junta Ø32xØ21x3	Joint washer Ø32xØ21x3	1	1	1	1
38	Q223023	Tuerca hexagonal 5/8"	Hexagonal nut 5/8"	1	1	1	1
39	Q881336	Abrazadera 16 - 27	Clamp 16 - 27	2	2	2	2
40	3715300	Tubo de goma Ø24xØ14x800	Rubber pipe Ø24xØ14x800	1	1	1	1
41	Z162312	Reducción	Reduction	1	1	1	1
42	Q881324	Abrazadera 50 - 70	Clamp 50 - 70	2	2	2	2
43	Z162301	Conducto impulsión	Impulse pipe	1	1	1	1
44	Z510924	Asa aliviadero preaclarado	Prerinse overflow handle	1	1	1	1
45	Q162050	Tuerca hexagonal M-8	Hexagonal nut M-8	1	1	1	1
46	Z510921	Aliviadero preaclarado soldado	Welded prerinse overflow	1	1	1	1
47	Z510941	Guía aliviadero preaclarado	Prerinse overflow guide	1	1	1	1
	Q262040	Arandela muelle A-6	Spring washer A-6	2	2	2	2
	Q212040	Tuerca sombrerete M-6	Cowl nut M-6	2	2	2	2
48	Z102104	Válvula desagüe	Drainage valve	1	1	1	1
49	Q307009	Arandela junta Ø70xØ48x1,5	Joint washer Ø70xØ48x10.5	1	1	1	1
50	Q307026	Junta especial	Special joint	1	1	1	1
51	Z702101	Tuerca rosca 1 1/2"	Nut thread 1 1/2"	1	1	1	1
52	Q307027	Arandela junta Ø45xØ35x2	Joint washer Ø45xØ35x2	1	1	1	1
53	Z602101	Codo desagüe	Drainage elbow	1	1	1	1
54	Z602102	Tuerca	Nut	1	1	1	1
55	Z510934	Manguera comunicación preaclaclar.	Prerinse connection pipe	1	1	1	1
56	Z310932	Codo empalme	Elbow joint	1	1	1	1

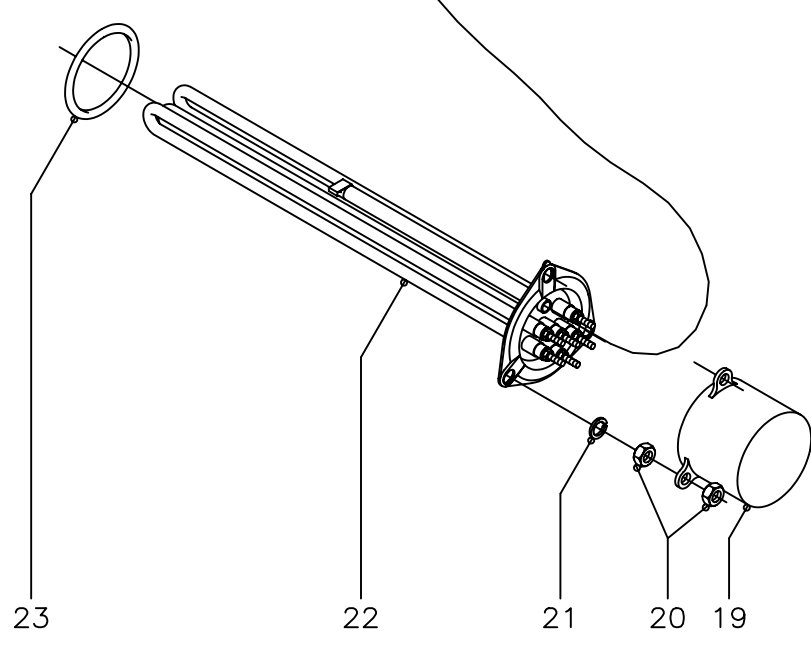
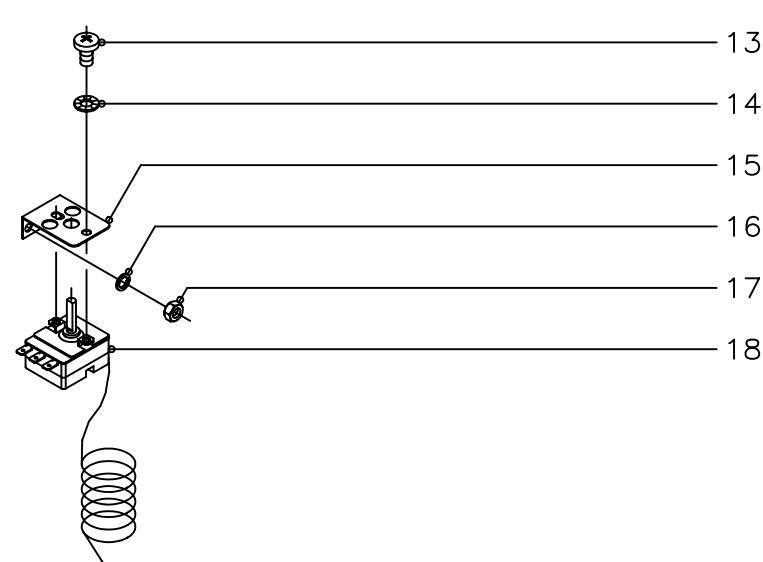
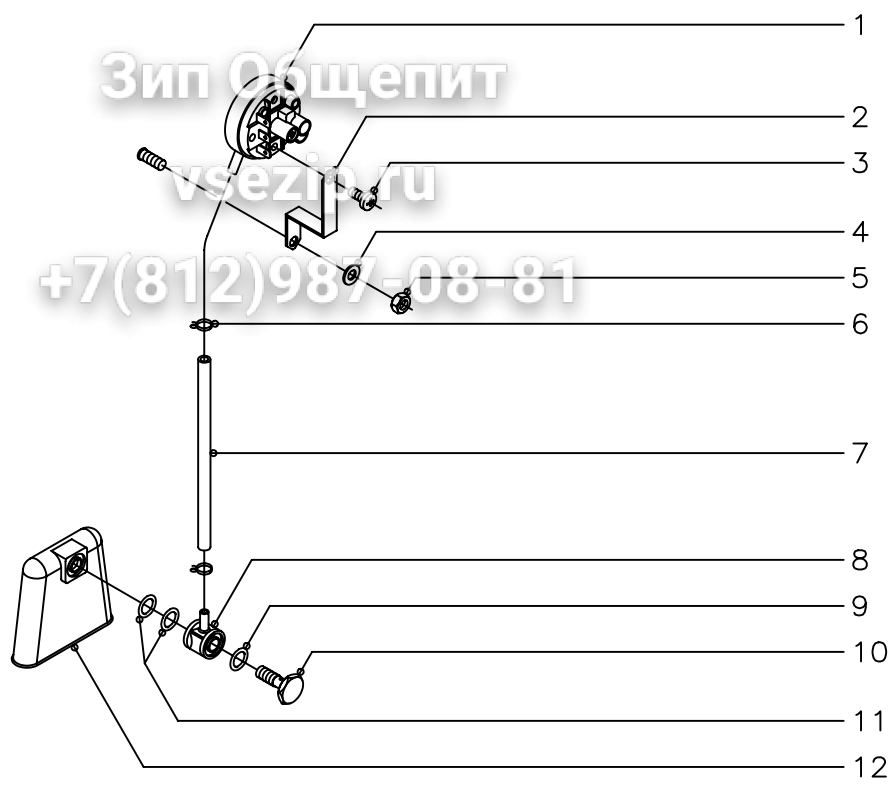

N plano C-1552	Firma 	Fecha 7-2004	Aparato LAVAVAJILLAS DE CINTA NIVELES Y CALENTAMIENTO PREAclarado	Lamina 8	Fagor Industrial S.Coop. FAGOR Onate
-------------------	-----------	-----------------	---	-------------	--

Зип Общепит

vsezip.ru

ZONA

MODULO DE PREACLARADO (Nivel

MOD.

LAVAVAJILLAS DE CINTA

+7(812)987-08-81

ITEM	CODIGO	DENOMINACION	TEXTO	2700 I	2700 D	4000 I	4000 D
1	Z313006	Presostato simple	Simple pressostat	1	1	1	1
2	P503068	Soporte presostato	Pressostat support	1	1	1	1
3	Q082032	Tornillo alomado BZ-3,5x9,5	Curved screw BZ-3.5x90.5	1	1	1	1
4	Q232040	Arandela plana A-6	Flat washer A-6	1	1	1	1
5	Q162040	Tuerca hexagonal M-6	Hexagonal nut M-6	1	1	1	1
6	P102154	Brida elástica	Elastic yoke	2	2	2	2
7	3702400	Tubo de goma Ø 8x4x130	Rubber pipe Ø 8x4x130	1	1	1	1
8	Z203012	Empalme presostato	Pressostat joint	1	1	1	1
9	Q307003	Junta tórica Ø16,01xØ10,77xØ2,62	"O" ring Ø16,01xØ10,77xØ20.62	1	1	1	1
10	Z203013	Tornillo presostato	Pressostat screw	1	1	1	1
11	Q307003	Junta tórica Ø16,01xØ10,77xØ2,62	"O" ring Ø16,01xØ10,77xØ20.62	2	2	2	2
12	Z203011	Cámara presostato	Pressostat chamber	1	1	1	1
13	Q152024	Tornillo avellanado M-4x8	Countersunk screw M-4x8	2	2	2	2
14	Q242020	Arandela abanico A-4	Fan shaped washer A-4	2	2	2	2
15	Z850111	Soporte termostato	Thermostat support	1	1	1	1
16	Q232040	Arandela plana A-6	Flat washer A-6	2	2	2	2
17	Q162040	Tuerca hexagonal M-6	Hexagonal nut M-6	2	2	2	2
18	Z203014	Termostato	Thermostat	1	1	1	1
19	Z101723	Caperuza resistencia	Resistor cap	2	2	2	2
20	Q163140	Tuerca hexagonal M-6 LATÓN	Brass hexagonal nut M-6	12	12	12	12
21	Q262040	Arandela muelle A-6	Spring washer A-6	6	6	6	6
22	Z313601	Resistencia 230 V., 5.000 W.	Resistance 230 V., 5,000 W.	2	2	2	2
23	Q307044	Junta tórica Ø67,18xØ56,52xØ5,30	"O" ring Ø67,18xØ56,52xØ50.30	2	2	2	2

Зип Общепит

vsezip.ru

+7(812)987-08-81

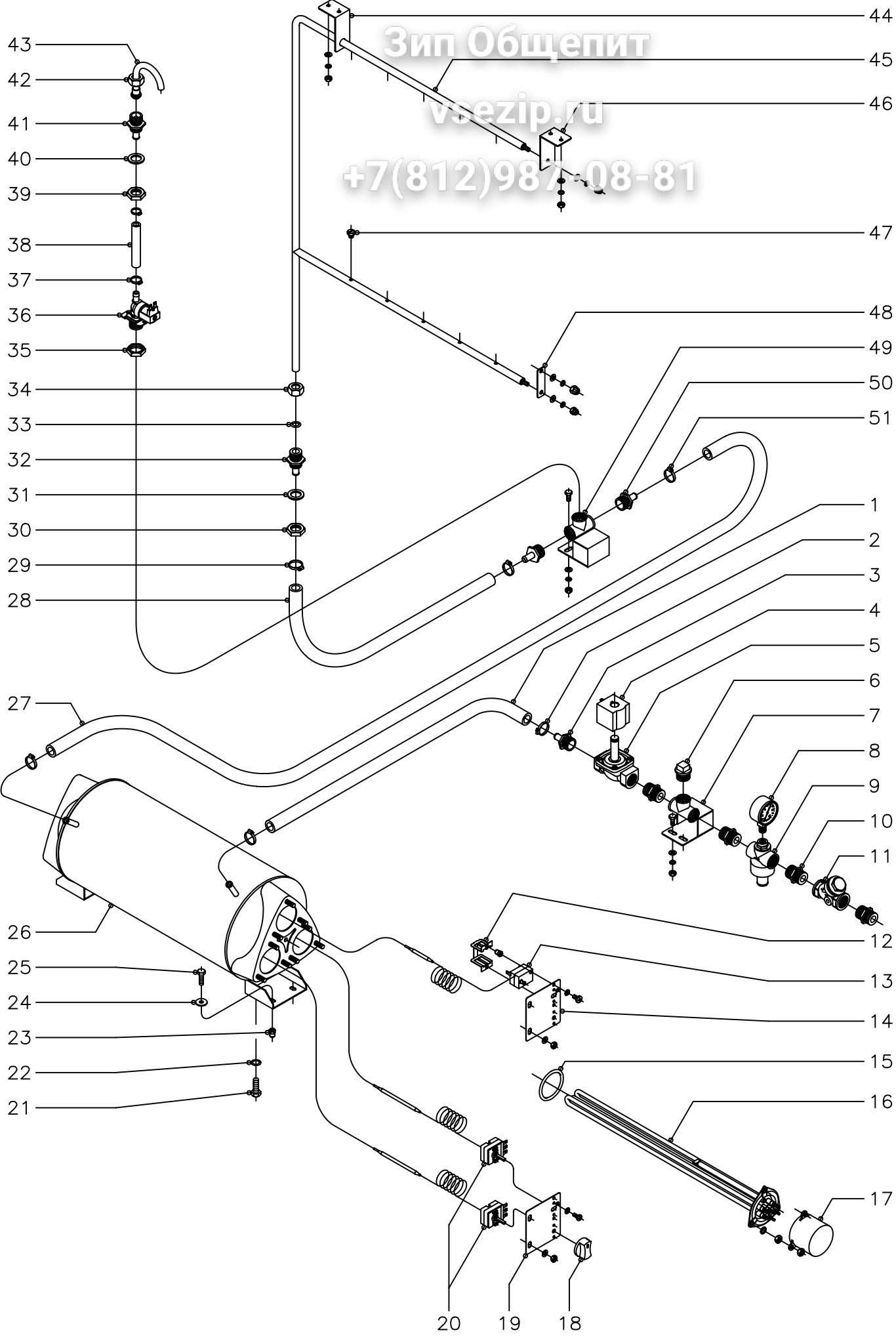

N plano
C-1553

Firma

Fecha
7-2004

Aparato
LAVAVAJILLAS DE CINTA (FI)
PARTE FUNCIONAL ACLARADO

Lamina
9

Fagor Industrial S.Coop. **FAGOR**
Onate

Зип Общепит

vsezip.ru

ZONA

+7(812)987-08-81

MOD.		LAVAVAJILLAS DE CINTA		ZONA		PARTE FUNCIONAL ACLA		
ITEM	CODIGO	DENOMINACION	TEXTO	FI-2700	FI-4000	FI-6000		
1	3715300	Tubo de goma Ø24xØ14x800	Rubber pipe Ø24xØ14x800	1	1	1		
2	Q881336	Abrazadera 27 - 16	Clamp 27 - 16	2	2	2		
3	Z316419	Empalme 3/4"	Joint 3/4"	1	1	1		
4	Z102323	Bobina para electroválvula	Coil for electrovalve	1	1	1		
5	Z102305	Electrovalvula 3/4"	Electrovalve 3/4"	1	1	1		
6	Z311103	Tapón 3/4"	Lid 3/4"	1	1	1		
7	Z311101	Te-soporte completo	Complete T support	1	1	1		
	Q012042	Tornillo hexagonal M-6x15	Hexagonal screw M-6x15	2	2	2		
	Q302022	Arandela plana Ø16xØ6x1,2	Flat washer Ø16xØ6x10.2	2	2	2		
	Q262040	Arandela muelle A-6	Spring washer A-6	2	2	2		
	Q162040	Tuerca hexagonal M-6	Hexagonal nut M-6	2	2	2		
8	Z102316	Manómetro	Pressure gauge	1	1	1		
9	Z102307	Reductor de presión	Pressure reducer	1	1	1		
10	Z102301	Manguito 3/4"	Socket 3/4"	4	4	4		
11	Z102308	Filtro 3/4"	Filter 3/4"	1	1	1		
12	Z203060	Amarre limitador Tecasa	Tecasa limiter anchoring	1	1	1		
	Q221341	Remache hexagonal M-4	Hexagonal rivet M-4	2	2	2		
	Q152024	Tornillo avellanado M-4x8	Countersunk screw M-4x8	2	2	2		
13	Z213014	Termostato limitador Tecasa	Tecasa limiter thermostat	1	1	1		
14	Z273037	Soporte termostatos	Thermostat supports	1	1	1		
	Q302022	Arandela plana Ø16xØ6x1,2	Flat washer Ø16xØ6x10.2	2	2	2		
	Q162040	Tuerca hexagonal M-6	Hexagonal nut M-6	2	2	2		
15	Q307044	Junta tórica Ø67,18xØ56,52x5,3	O" ring Ø67,18xØ56,52xØ500.3	3	3	3		
16	Z129502	Resistencia 230 V., 12.000 W.	Resistance 230 V., 12,000 W.	3	3	3		
17	Z101723	Caperuza resistencia	Resistor cap	3	3	3		
	Q262040	Arandela muelle A-6	Spring washer A-6	9	9	9		
	Q163140	Tuerca hexagonal M-6 latón	Brass hexagonal nut M-6	18	18	18		
18	R663062	Botón de mando completo	Complete control button	1	1	1		
19	Z273037	Soporte termostatos	Thermostat support	1	1	1		

Зип Общепит

vsezip.ru

ZONA

PARTE FUNCIONAL ACLA

MOD.

LAVAVAJILLAS DE CINTA

+7(812)987-08-81

ITEM	CODIGO	DENOMINACION	TEXTO	FI-2700	FI-4000	FI-6000	
	Q302022	Arandela plana Ø16xØ6x1,2	Flat washer Ø16xØ6x10.2	2	2	2	
	Q162040	Tuerca hexagonal M-6	Hexagonal nut M-6	2	2	2	
20	Z203014	Termostato calderin	Wash drum thermostat	2	2	2	
	Q152024	Tornillo avellanado M-4x8	Countersunk screw M-4x8	2	2	2	
21	Q012063	Tornillo hexagonal M-10x20	Hexagonal screw M-10x20	1	1	1	
22	Q307048	Junta tórica Ø16,18xØ9,12xØ3,53	"O" ring Ø16,18xØ9,12xØ30.53	1	1	1	
23	Q221343	Remache hexagonal M-6	Hexagonal rivet M-6	4	4	4	
24	Q302022	Arandela plana Ø16xØ6x1,2	Flat washer Ø16xØ6x10.2	4	4	4	
25	Q012042	Tornillo hexagonal M-6x15	Hexagonal screw M-6x15	4	4	4	
26	Z316426	Cuerpo calderin completo	Complete wash drum body	1	1	1	
27	3715300	Tubo de goma Ø24xØ14x1.100	Rubber pipe Ø24xØ14x1.100	1	1	1	
28	3715300	Tubo de goma Ø24xØ14x1.100	Rubber pipe Ø24xØ14x1.100	1	1	1	
29	Q881336	Abrazadera 27 - 16	Clamp 27 - 16	2	2	2	
30	Q223023	Tuerca hexagonal 5/8"	Hexagonal nut 5/8"	1	1	1	
31	Q307032	Arandela junta Ø32xØ21x3	Joint washer Ø32xØ21x3	1	1	1	
32	Z281901	Pasamuros aclarado	Rinse wire protection	1	1	1	
33	Q307063	Junta tórica Ø19,35xØ12,29xØ3,53	"O" ring Ø19,35xØ12,29xØ30.53	1	1	1	
34	Q223108	Tuerca M-24x2,5	Nut M-24x20.5	1	1	1	
35	Q221324	Tuerca hexagonal 3/4" gas	Hexagonal nut 3/4" gas	1	1	1	
36	Z701135	Electroválvula entrada agua simple	Simple water inlet electrovalve	1	1	1	
37	Q881302	Abrazadera 12 - 20	Clamp 12 - 20	2	2	2	
38	3676900	Tubo de goma Ø17xØ10x1.700	Rubber pipe Ø17xØ10x1.700	1	1	1	
39	Q223023	Tuerca hexagonal 5/8"	Hexagonal nut 5/8"	1	1	1	
40	Q307032	Arandela junta Ø32xØ21x3	Joint washer Ø32xØ21x3	1	1	1	
41	Z821910	Pasamuros conducto llenado	Filling pipe wire protection	1	1	1	
42	Q223106	Tuerca unión conducto	Pipe nut joint	1	1	1	
43	Z331101	Conducto de llenado	Filling pipe	1	1	1	
44	Z511905	Amarre superior aclarado "A"	Upper anchoring rinse "A"	1	1	1	
	Q302022	Arandela plana Ø16xØ6x1,2	Flat washer Ø16xØ6x10.2	2	2	2	

Зип Общепит

vsezip.ru

ZONA

+7(812)987-08-81

MOD.		LAVAVAJILLAS DE CINTA		ZONA		PARTE FUNCIONAL ACLARADO			
ITEM	CODIGO	DENOMINACION	TEXTO	FI-2700	FI-4000	FI-6000			
	Q262040	Arandela muelle A-6	Spring washer A-6	2	2	2			
	Q162040	Tuerca hexagonal M-6	Hexagonal nut M-6	2	2	2			
45	Z511901	Árbol aclarado completo	Complete rinse arbour	1	1	1			
	Q232040	Arandela plana A-6	Flat washer A-6	2	2	2			
	Q262030	Arandela muelle A-5	Spring washer A-5	2	2	2			
	Q212031	Tuerca sombrerete M-5	Cowl nut M-5	2	2	2			
46	Z511906	Amarre superior aclarado "B"	Upper anchoring rinse "B"	1	1	1			
	Q302022	Arandela plana Ø16xØ6x1,2	Flat washer Ø16xØ6x10.2	2	2	2			
	Q262040	Arandela muelle A-6	Spring washer A-6	2	2	2			
	Q162040	Tuerca hexagonal M-6	Hexagonal nut M-6	2	2	2			
47	Z211903	Tobera de aclarado	Rinse nozzle	10	10	10			
48	Z511907	Sujeción rama inferior aclarado	Rinse lower branch fastening	1	1	1			
	Q232040	Arandela plana A-6	Flat washer A-6	1	1	1			
	Q262040	Arandela muelle A-6	Spring washer A-6	1	1	1			
	Q212040	Tuerca sombrerete M-6	Cowl nut M-6	1	1	1			
49	Z311101	Te-soporte completo	Complete T support	1	1	1			
	Q012042	Tornillo hexagonal M-6x15	Hexagonal screw M-6x15	2	2	2			
	Q302022	Arandela plana Ø16xØ6x1,2	Flat washer Ø16xØ6x10.2	2	2	2			
	Q262040	Arandela muelle A-6	Spring washer A-6	2	2	2			
	Q162040	Tuerca hexagonal M-6	Hexagonal nut M-6	2	2	2			
50	Z316419	Empalme 3/4"	Joint 3/4"	2	2	2			
51	Q881336	Abrazadera 27 - 16	Clamp 27 - 16	2	2	2			

Зип Общепит

vsezip.ru

+7(812)987-08-81

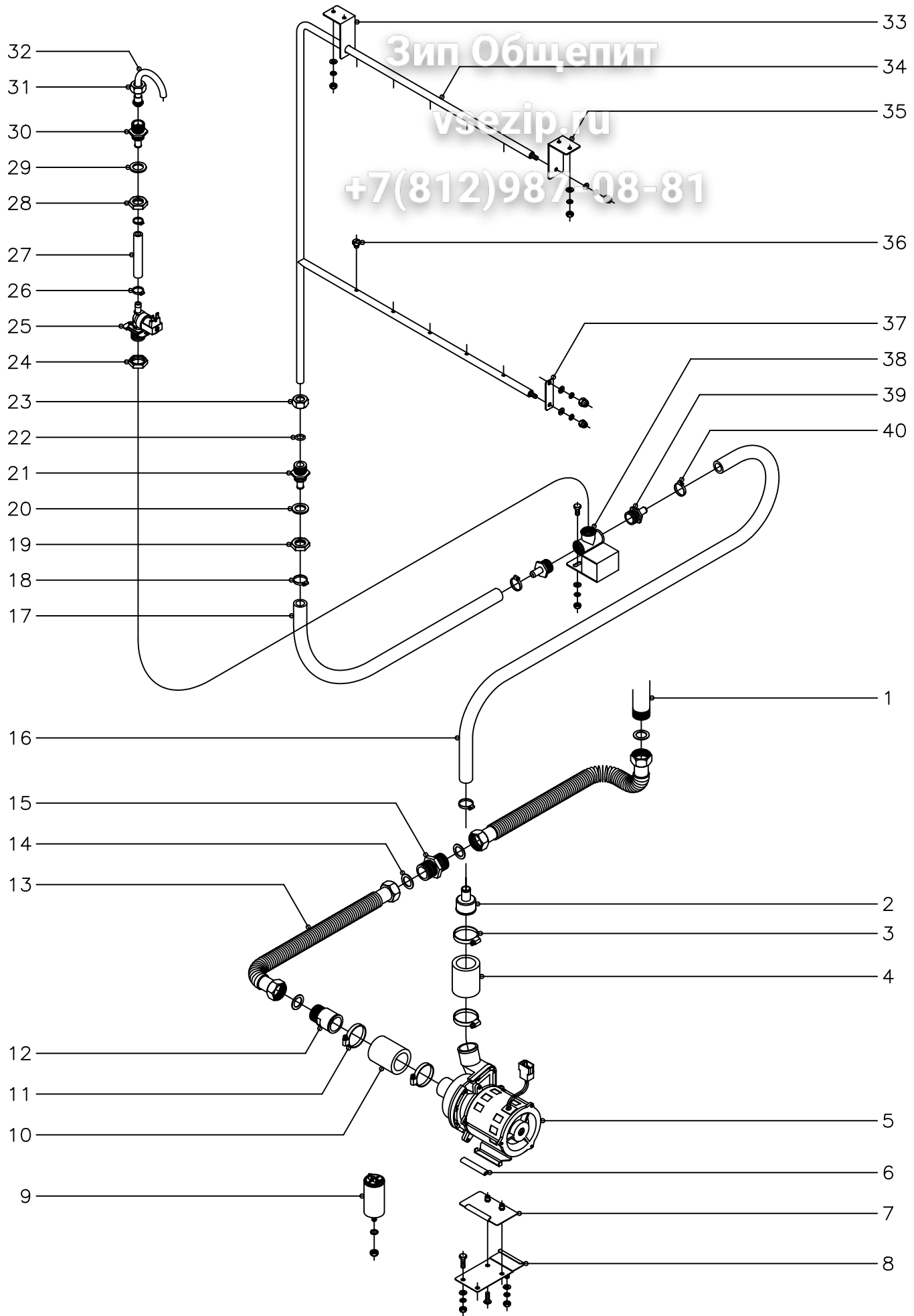

Зип Общепит

vsezip.ru

ZONA

MOD.

LAVAVAJILLAS DE CINTA

PARTE FUNCIONAL ACLAR

+7(812)987-08-81

ITEM	CODIGO	DENOMINACION	TEXTO	ECO-2700	ECO-4000	ECO-6000	
1	-	Salida de generador agua caliente	Hot water generator outlet	1	1	1	
2	Z162312	Reducción	Reduction	1	1	1	
3	Q881324	Abrazadera 50 - 70	Clamp 50 - 70	2	2	2	
4	Z162301	Conducto aspiración - impulsión	Extractor pipe - impulse	1	1	1	
5	Z401001	Motobomba de aclarado	Rinse motor pump	1	1	1	
6	Z401007	Perfil soporte motobomba	Motor pump support profile	2	2	2	
7	Z162313	Amarre motobomba completo	Complete motor pump anchoring	1	1	1	
	Q152004	Tornillo aplastado M-5x13	Screw M-5x13	2	2	2	
8	Z162315	Soporte motobomba completo	Complete motor pump support	1	1	1	
	Q012042	Tornillo hexagonal M-6x15	Hexagonal screw M-6x15	2	2	2	
	Q302022	Arandela plana Ø16xØ6x1,2	Flat washer Ø16xØ6x10.2	5	5	5	
	Q262040	Arandela muelle A-6	Spring washer A-6	3	3	3	
	Q162040	Tuerca hexagonal M-6	Hexagonal nut M-6	3	3	3	
9	V817100	Condensador 6 Mf.	Condensor 6 Mf.	1	1	1	
	Q261050	Arandela muelle A-8	Spring washer A-8	1	1	1	
	Q162050	Tuerca hexagonal M-8	Hexagonal nut M-8	1	1	1	
10	Z162301	Conducto aspiración - impulsión	Extractor pipe - impulse	1	1	1	
11	Q881324	Abrazadera 50 - 70	Clamp 50 - 70	2	2	2	
12	Z701102	Manguito	Socket	1	1	1	
13	Z951101	Tubería flexible L=1.000	Flexible tube L=1,000	3	3	3	
14	Q306038	Arandela junta Ø31xØ21x1,5	Joint washer Ø31xØ21x10.5	6	6	6	
15	Z162306	Manguito doble 1"	Double socket 1"	2	2	2	
16	3715300	Tubo de goma Ø24xØ14x1300	Rubber pipe Ø24xØ14x1300	1	1	1	
17	3715300	Tubo de goma Ø24xØ14x1300	Rubber pipe Ø24xØ14x1300	1	1	1	
18	Q881336	Abrazadera 16 - 27	Clamp 16 - 27	2	2	2	
19	Q223023	Tuerca hexagonal 5/8"	Hexagonal nut 5/8"	1	1	1	
20	Q307032	Arandela junta Ø32xØ21x3	Joint washer Ø32xØ21x3	1	1	1	
21	Z281901	Pasamuros aclarado	Rinse wire protection	1	1	1	
22	Q307063	Junta tórica Ø19,35xØ12,29xØ3,53	"O" ring Ø19,35xØ12,29xØ30.53	1	1	1	

Зип Общепит

vsezip.ru

ZONA

+7(812)987-08-81

MOD.		LAVAVAJILLAS DE CINTA		PARTE FUNCIONAL ACLAR		
ITEM	CODIGO	DENOMINACION	TEXTO	ECO-2700	ECO-4000	ECO-6000
23	Q223108	Tuerca M-24x2,5	Nut M-24x20.5	1	1	1
24	Q221324	Tuerca hexagonal 3/4" gas	Hexagonal nut 3/4" gas	1	1	1
25	Z701135	Electrovalvula entrada agua simple	Simple water inlet electrovalve	1	1	1
26	Q881302	Abrazadera 12 - 20	Clamp 12 - 20	2	2	2
27	3676900	Tubo de goma Ø17xØ10x1.700	Rubber pipe Ø17xØ10x1.700	1	1	1
28	Q223023	Tuerca hexagonal 5/8"	Hexagonal nut 5/8"	1	1	1
29	Q307032	Arandela junta Ø32xØ21x3	Joint washer Ø32xØ21x3	1	1	1
30	Z821910	Pasamuros conducto llenado	Filling pipe wire protection	1	1	1
31	Q223106	Tuerca unión conducto	Pipe nut joint	1	1	1
32	Z331101	Conducto de llenado	Filling pipe	1	1	1
33	Z511905	Amarre superior aclarado "A"	Upper anchoring rinse "A"	1	1	1
	Q302022	Arandela plana Ø16xØ6x1,2	Flat washer Ø16xØ6x10.2	2	2	2
	Q262040	Arandela muelle A-6	Spring washer A-6	2	2	2
	Q162040	Tuerca hexagonal M-6	Hexagonal nut M-6	2	2	2
34	Z511901	Árbol aclarado completo	Complete rinse arbour	1	1	1
	Q232040	Arandela plana A-6	Flat washer A-6	2	2	2
	Q262030	Arandela muelle A-5	Spring washer A-5	2	2	2
	Q212031	Tuerca sombrerete M-5	Cowl nut M-5	2	2	2
35	Z511906	Amarre superior aclarado "B"	Upper anchoring rinse "B"	1	1	1
	Q302022	Arandela plana Ø16xØ6x1,2	Flat washer Ø16xØ6x10.2	2	2	2
	Q262040	Arandela muelle A-6	Spring washer A-6	2	2	2
	Q162040	Tuerca hexagonal M-6	Hexagonal nut M-6	2	2	2
36	Z211903	Tobera de aclarado	Rinse nozzle	10	10	10
37	Z511907	Sujeción rama inferior aclarado	Rinse lower branch fastening	1	1	1
	Q232040	Arandela plana A-6	Flat washer A-6	1	1	1
	Q262040	Arandela muelle A-6	Spring washer A-6	1	1	1
	Q212040	Tuerca sombrerete M-6	Cowl nut M-6	1	1	1
38	Z311101	Te-soporte completo	Complete T support	1	1	1
	Q012042	Tornillo hexagonal M-6x15	Hexagonal screw M-6x15	2	2	2

Зип Общепит

vsezip.ru

+7(812)987-08-81

N plano
C-1555

Firma

Fecha
7-2004

Aparato
LAVAVAJILLAS DE CINTA
SISTEMA DE ARRASTRE

Lamina
11

Fagor Industrial S. Coop.
Onote

FAGOR 

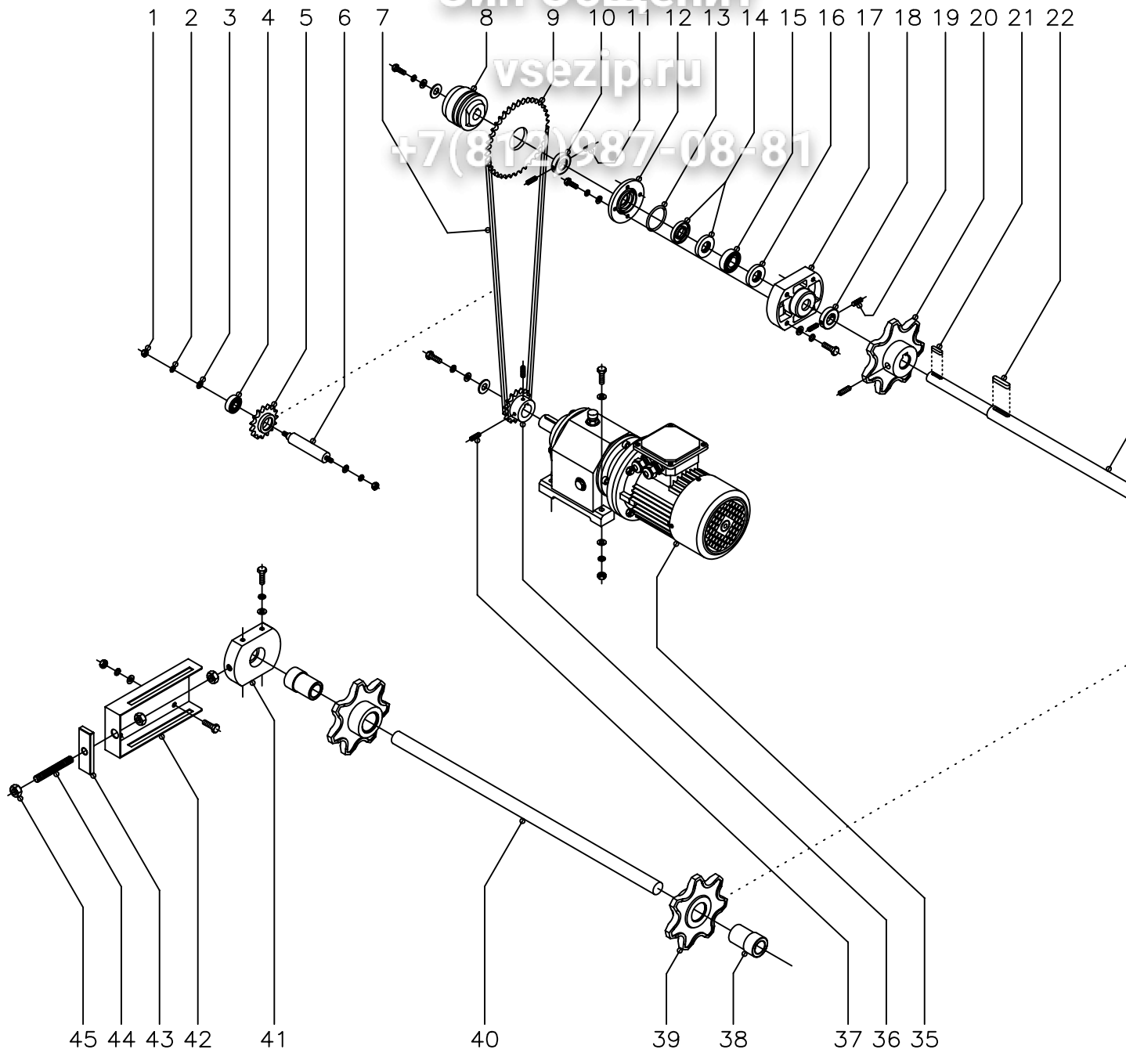

Зип Общепит

vsezip.ru

ZONA

SISTEMA DE ARRAS

MOD.

LAVAVAJILLAS DE CINTA

+7(812)987-08-81

ITEM	CODIGO	DENOMINACION	TEXTO	2700	4000	6000	
1	Q222012	Tuerca hexagonal autoblocante M-6	Autolocking hexagonal nut M-6	1	1	1	
2	Q262040	Arandela muelle A-6	Spring washer A-6	1	1	1	
3	Q302022	Arandela plana Ø16xØ6x1,2	Flat washer Ø16xØ6x10.2	1	1	1	
4	Z515007	Rodamiento 6201 - 2Z	Bearing 6201 - 2Z	1	1	1	
5	Z515006	Piñón tensor cadena (Z=13)	Chain turnbuckle pinion (Z=13)	1	1	1	
6	Z515005	Eje piñón tensor	Turnbuckle pinion spindle	1	1	1	
	Q232050	Arandela plana A-8	Flat washer A-8	1	1	1	
	Q262050	Arandela muelle A-8	Spring washer A-8	1	1	1	
	Q162050	Tuerca hexagonal M-8x1	Hexagonal nut M-8x1	1	1	1	
7	Z275008	Cadena Iris 12,7x7,95x730	Iris chain 12.7x7.95x730	1	1	1	
	Z105012	Enganche extremos cadena	Chain end hook	1	1	1	
8	Z105008	Limitador de par LS-70	Torque limiter LS-70	1	1	1	
	Q012042	Tornillo hexagonal M-6x15	Hexagonal screw M-6x15	1	1	1	
	Q262040	Arandela muelle A-6	Spring washer A-6	1	1	1	
	Q232040	Arandela plana A-6	Flat washer A-6	1	1	1	
	Q301010	Arandela plana Ø27xØ12,5x2,5	Flat washer Ø27xØ12,5x20.5	1	1	1	
9	Z515008	Corona 2700 (Z=50)	Annulus 2700 (Z=50)	1	-	-	
9	Z535008	Corona 4000 (Z=36)	Annulus 4000 (Z=36)	-	1	-	
9	Z555008	Corona 6000 (Z=25)	Annulus 6000 (Z=25)	-	-	1	
10	Z515024	Tope rueda motriz	Driver buffer	1	1	1	
11	Q132002	Varilla roscada M-5x16	Threaded rod M-5x16	2	2	2	
12	Z515016	Cubierta posterior rodamientos	Bearings rear cover	1	1	1	
	Q012042	Tornillo hexagonal M-6x15	Hexagonal screw M-6x15	4	4	4	
	Q262040	Arandela muelle A-6	Spring washer A-6	4	4	4	
	Q232040	Arandela plana A-6	Flat washer A-6	4	4	4	
13	Q307071	Junta tórica Ø51,1xØ44,04xØ3,53	"O" ring Ø51,1xØ44,04xØ30.53	1	1	1	
14	Z515015	Reten Ø42xØ20x7	Retainer Ø42xØ20x7	2	2	2	
15	Z515014	Rodamiento 6004 - 2RS	Bearing 6004 - 2RS	1	1	1	
16	Z515015	Reten Ø42xØ20x7	Retainer Ø42xØ20x7	1	1	1	

Зип Общепит

vsezip.ru

ZONA

+7(812)987-08-81

MOD.		LAVAVAJILLAS DE CINTA	ZONA		SISTEMA DE ARRAS		
ITEM	CODIGO	DENOMINACION	TEXTO	2700	4000	6000	
17	Z515013	Soporte rodamiento	Bearing support	1	1	1	
	Q012053	Tornillo hexagonal M-8x20	Hexagonal screw M-8x20	4	4	4	
	Q262050	Arandela muelle A-8	Spring washer A-8	4	4	4	
	Q232050	Arandela plana A-8	Flat washer A-8	4	4	4	
18	Z515024	Tope rueda motriz	Driver buffer	1	1	1	
19	Q132002	Varilla roscada M-5x16	Threaded rod M-5x16	2	2	2	
20	Z515021	Rueda motriz completa	Complete driver	1	1	1	
	Q132001	Varilla roscada M-8x16	Threaded rod M-8x16	1	1	1	
21	Z105014	Chaveta 25x6x6	Key 25x6x6	1	1	1	
22	Z515012	Chaveta 40x8x7	Key 40x8x7	1	1	1	
23	Z515011	Eje motriz	Driving pin	1	1	1	
24	Z515012	Chaveta 40x8x7	Key 40x8x7	1	1	1	
25	Z515021	Rueda motriz completa	Complete driver	1	1	1	
26	Q132001	Varilla roscada M-8x16	Threaded rod M-8x16	1	1	1	
27	Z515024	Tope rueda motriz	Driver buffer	1	1	1	
28	Q132002	Varilla roscada M-5x16	Threaded rod M-5x16	2	2	2	
29	Z515013	Soporte rodamiento	Bearing support	1	1	1	
	Q012053	Tornillo hexagonal M-8x20	Hexagonal screw M-8x20	4	4	4	
	Q262050	Arandela muelle A-8	Spring washer A-8	4	4	4	
	Q232050	Arandela plana A-8	Flat washer A-8	4	4	4	
30	Z515015	Reten Ø42xØ20x7	Retainer Ø42xØ20x7	1	1	1	
31	Z515014	Rodamiento 6004 - 2RS	Bearing 6004 - 2RS	1	1	1	
32	Z515015	Reten Ø42xØ20x7	Retainer Ø42xØ20x7	2	2	2	
33	Q307071	Junta tórica Ø51,1xØ44,04xØ3,53	"O" ring Ø51,1xØ44,04xØ3,53	1	1	1	
34	Z515018	Cubierta anterior rodamientos	Bearings front cover	1	1	1	
	Q012042	Tornillo hexagonal M-6x15	Hexagonal screw M-6x15	4	4	4	
	Q262040	Arandela muelle A-6	Spring washer A-6	4	4	4	
	Q232040	Arandela plana A-6	Flat washer A-6	4	4	4	
35	Z515001	Motorreductor	Geared motor	1	1	1	

Зип Общепит

vsezip.ru

+7(812)987-08-81

MOD.		LAVAVAJILLAS DE CINTA	ZONA	SISTEMA DE ARRAS			
ITEM	CODIGO	DENOMINACION	TEXTO	2700	4000	6000	
	Q012055	Tornillo hexagonal M-8x30	Hexagonal screw M-8x30	4	4	4	
	Q232050	Arandela plana A-8	Flat washer A-8	8	8	8	
	Q262050	Arandela muelle A-8	Spring washer A-8	4	4	4	
	Q162050	Tuerca hexagonal M-8x1	Hexagonal nut M-8x1	4	4	4	
36	Z515002	Piñón motorreductor (Z=15)	Geared motor pinion (Z=15)	1	1	1	
	Q012052	Tornillo hexagonal M-8x15	Hexagonal screw M-8x15	1	1	1	
	Q262050	Arandela muelle A-8	Spring washer A-8	1	1	1	
	Q232050	Arandela plana A-8	Flat washer A-8	1	1	1	
	Q301010	Arandela plana Ø27xØ12,5x2,5	Flat washer Ø27xØ12,5x20.5	1	1	1	
37	Q132041	Varilla roscada M-6x10	Threaded rod M-6x10	2	2	2	
38	Z515036	Casquillo eje auxiliar	Auxiliary spindle socket	2	2	2	
39	Z515033	Rueda auxiliar completa	Complete auxiliary wheel	2	2	2	
40	Z515032	Eje auxiliar	Auxiliary spindle	1	1	1	
41	Z515031	Tensor	Turnbuckle	2	2	2	
	Q012052	Tornillo hexagonal M-8x15	Hexagonal screw M-8x15	8	8	8	
	Q262050	Arandela muelle A-8	Spring washer A-8	8	8	8	
	Q232050	Arandela plana A-8	Flat washer A-8	8	8	8	
42	Z510438	Soporte tensor	Turnbuckle support	2	2	2	
	Q012052	Tornillo hexagonal M-8x15	Hexagonal screw M-8x15	8	8	8	
	Q232050	Arandela plana A-8	Flat washer A-8	8	8	8	
	Q262050	Arandela muelle A-8	Spring washer A-8	8	8	8	
	Q162050	Tuerca hexagonal M-8x1	Hexagonal nut M-8x1	8	8	8	
43	Z510439	Calzo tensor	Turnbuckle wedge	2	2	2	
44	Z510437	Espárrago roscado M-12x90	Threaded stud-bolt M-12x90	2	2	2	
45	Q162070	Tuerca hexagonal M-12	Hexagonal nut M-12	6	6	6	

Зип Общепит

vsezip.ru

+7(812)987-08-81

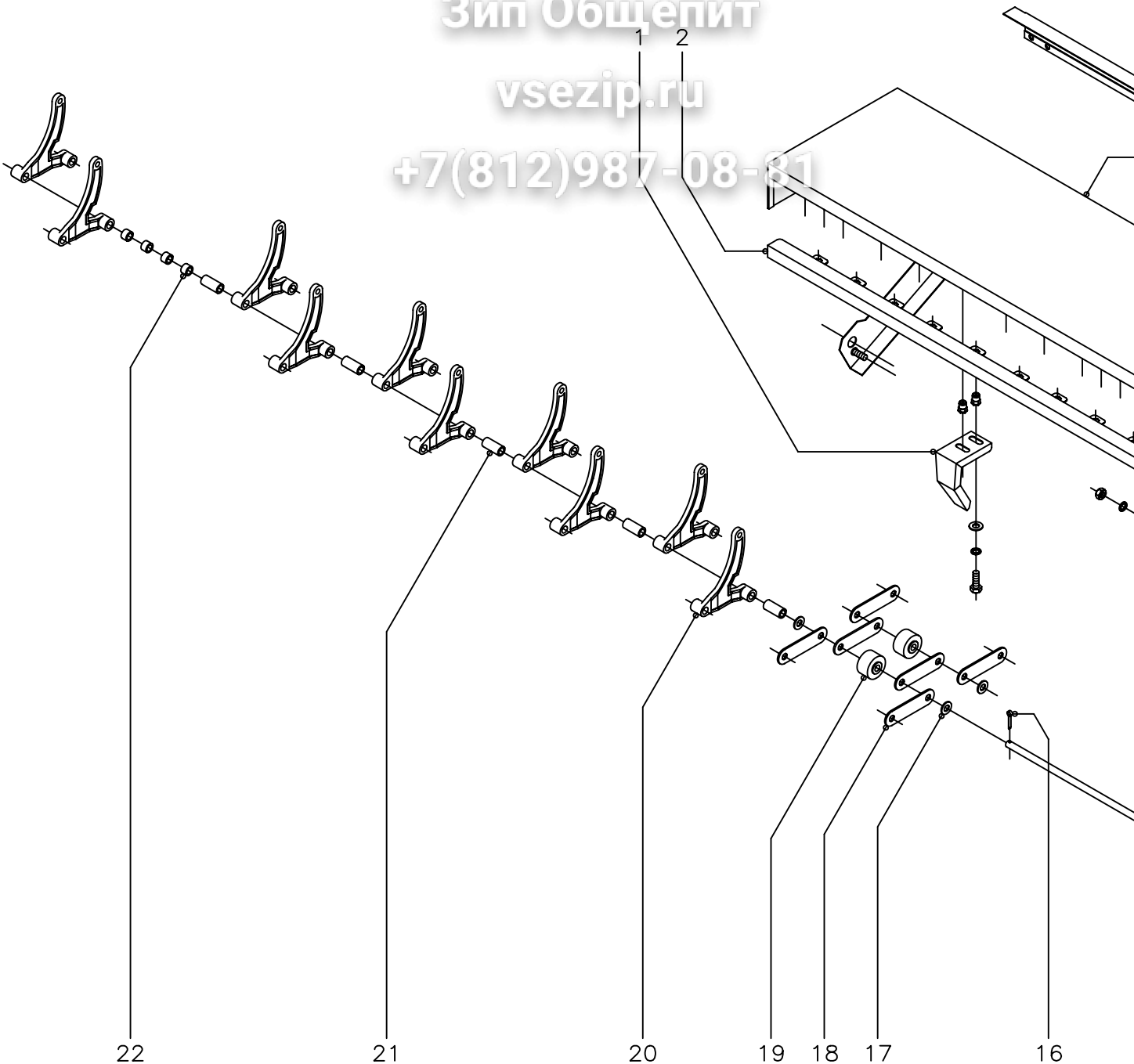

N plano
C-1556

Firma

Fecha
7-2004

Aparato
LAVAVAJILLAS DE CINTA
CINTA Y TOPE PLATOS

Lamina
12

Fagor Industrial S. Coop.
Orate

Зип Общепит

vsezip.ru

ZONA

CINTA Y TOPE PLAT

MOD.

LAVAVAJILLAS DE CINTA

+7(812)987-08-81

ITEM	CODIGO	DENOMINACION	TEXTO	2700	4000	6000	
1	Z512946	Suplemento tope platos	Plate buffer supplement	9	9	9	
	Q012031	Tornillo hexagonal M-5x10	Hexagonal screw M-5x10	18	18	18	
	Q262030	Arandela muelle A-5	Spring washer A-5	18	18	18	
	Q302022	Arandela plana Ø16xØ6x1,2	Flat washer Ø16xØ6x10.2	18	18	18	
2	Z512945	Soporte suplemento tope platos	Extra plate buffer support	1	1	1	
	Q221342	Remache hexagonal M-5	Hexagonal rivet M-5	18	18	18	
3	Z512944	Amarre resorte	Spring anchoring	1	1	1	
4	Z512937	Tope platos completo	Complete plate buffer	1	1	1	
5	Z512955	Resorte tope platos	Plate buffer spring	2	2	2	
6	Z512954	Sujeción resorte	Spring support	2	2	2	
	Q262030	Arandela muelle A-5	Spring washer A-5	2	2	2	
	Q162030	Tuerca hexagonal M-5	Hexagonal nut M-5	2	2	2	
7	Z512951	Eje tope platos soldado	Welded plate buffer spindle	2	2	2	
	Q302022	Arandela plana Ø16xØ6x1,2	Flat washer Ø16xØ6x10.2	2	2	2	
	Q262040	Arandela muelle A-6	Spring washer A-6	2	2	2	
	Q162040	Tuerca hexagonal M-6	Hexagonal nut M-6	2	2	2	
8	Z511201	Casquillo roscado 5/8"	Threaded bush 5/8"	2	2	2	
9	Q307032	Arandela junta Ø32xØ21x3	Joint washer Ø32xØ21x3	2	2	2	
10	Q223023	Tuerca hexagonal 5/8"	Hexagonal nut 5/8"	2	2	2	
11	Z511209	Leva	Cam	1	1	1	
12	Q371031	Manguito sujeción Ø3x20	Fastening socket Ø3x20	1	1	1	
13	Z513007	Final de carrera (Micro tope platos)	End of run (Micro plate buffer)	1	1	1	
	Q152026	Tornillo avellanado M-4x35	Countersunk screw M-4x35	2	2	2	
	Q242020	Arandela abanico A-4	Fan shaped washer A-4	2	2	2	
	Q162020	Tuerca hexagonal M-4	Hexagonal nut M-4	2	2	2	
14	Z511231	Soporte micro aclarado	Micro rinse support	1	1	1	
	Q232040	Arandela plana A-6	Flat washer A-6	2	2	2	
	Q222012	Tuerca hexagonal autoblocante M-6	Autolocking hexagonal nut M-6	2	2	2	
15	Z515039	Eje cinta	Belt spindle	147	177	207	

Zip Общий

vsezip.ru

+7(812)987-08-81

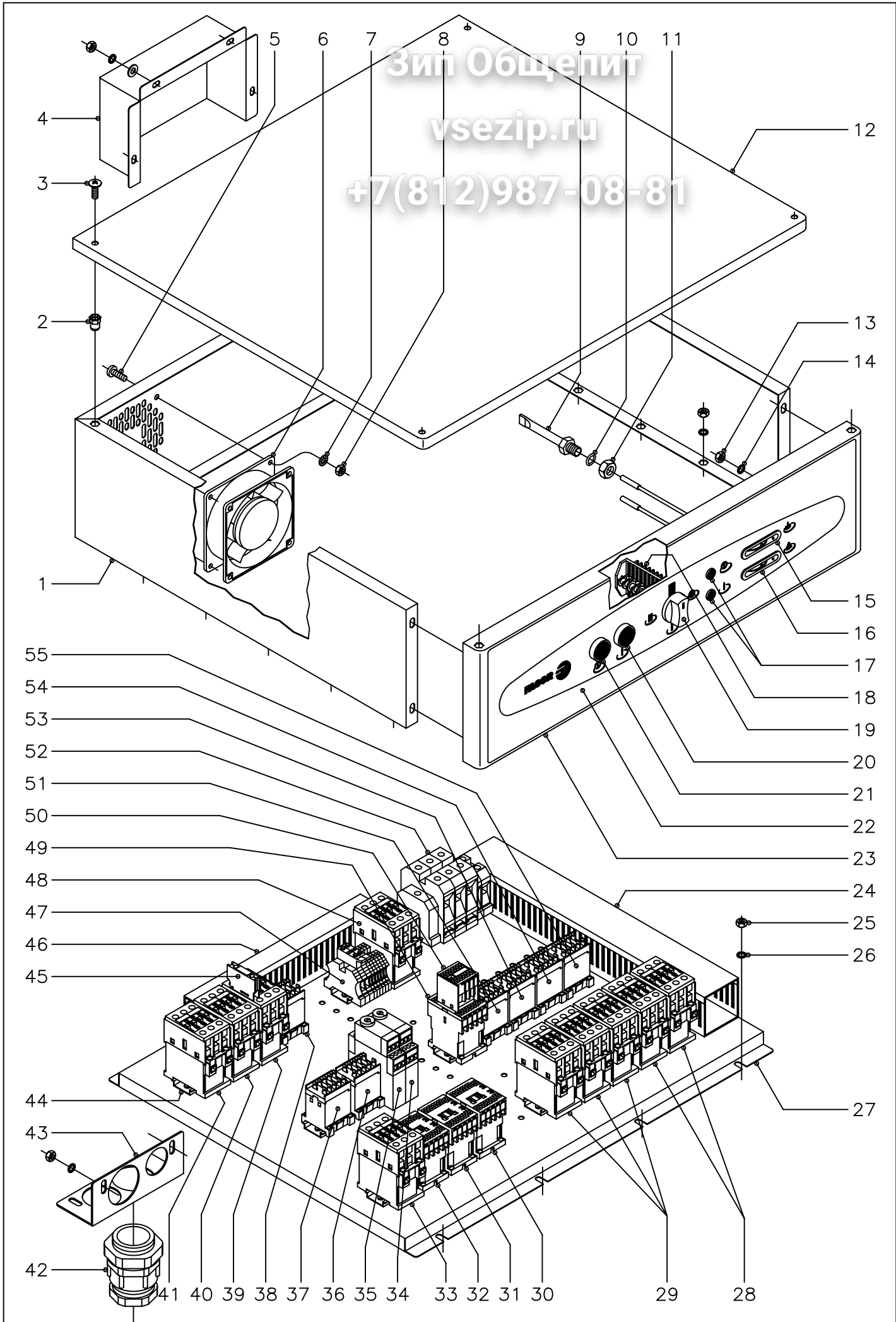

N plano C-1557	Firma 	Fecha 7-2004	Aparato LAVAVAJILLAS DE CINTA PARTE ELECTRICA	Lamina 13	Fagor Industrial S.Coop. FAGOR Onate
-------------------	-----------	-----------------	---	--------------	--

Зип Общепит

vsezip.ru

ZONA

PARTE ELECT

+7(812)987-08-81

MOD.		LAVAVAJILLAS DE CINTA		ZONA		PARTE ELECT			
ITEM	CODIGO	DENOMINACION	TEXTO	FI-2700	FI-4000	FI-6000	ECO-2700		
1	Z513012	Cubierta cuadro eléctrico completo	Complete switchboard cover	1	1	1	1		
	Q262040	Arandela muelle A-6	Spring washer A-6	12	12	12	12		
	Q162040	Tuerca hexagonal M-6	Hexagonal nut M-6	12	12	12	12		
2	Q221343	Remache hexagonal M-6	Hexagonal rivet M-6	4	4	4	4		
3	Q152017	Tornillo amarre M-6x13	Anchoring screw M-6x13	4	4	4	4		
4	Z513017	Posterior cuadro eléctrico	Switchboard rear	1	1	1	1		
	Q302022	Arandela plana Ø16xØ6x1,2	Flat washer Ø16xØ6x10.2	4	4	4	4		
	Q262040	Arandela muelle A-6	Spring washer A-6	4	4	4	4		
	Q162040	Tuerca hexagonal M-6	Hexagonal nut M-6	4	4	4	4		
5	Q031322	Tornillo alomado M-4x15	Curved screw M-4x15	4	4	4	4		
6	Z103066	Ventilador 230 V., 50/60 Hz.	Ventilator 230 V., 50/60 Hz.	1	1	1	1		
7	Q242020	Arandela abanico A-4	Fan shaped washer A-4	4	4	4	4		
8	Q162020	Tuerca hexagonal M-4	Hexagonal nut M-4	4	4	4	4		
9	Z263002	Vaina para bulbo	Case for bulb	1	1	1	1		
10	Q307048	Junta tórica Ø16,18xØ9,12xØ3,53	"O" ring Ø16,18xØ9,12xØ3.53	1	1	1	1		
11	Q162070	Tuerca hexagonal M-12	Hexagonal nut M-12	1	1	1	1		
12	Z513016	Tapa cuadro eléctrico	Switchboard lid	1	1	1	1		
13	Q162040	Tuerca hexagonal M-6	Hexagonal nut M-6	4	4	4	4		
14	Q262040	Arandela muelle A-6	Spring washer A-6	4	4	4	4		
15	Z263001	Indicador analógico (cuba lavado)	Analogical indicator (wash tub)	1	1	1	1		
16	Z263001	Indicador analógico (calderín acl.)	Analogical indicator (rinse wash tub)	1	1	1	-		
17	R693056	Piloto ámbar	Amber pilot light	2	2	2	2		
18	Z273005	Conmutador de funciones	Function switch	1	1	1	1		
	Z602906	Casquillo distanciador	Spacer socket	2	2	2	2		
	Q041324	Tornillo avellanado M-4x25	Countersunk screw M-4x25	2	2	2	2		
19	R663062	Botón de mando completo	Complete control button	1	1	1	1		
20	Z513003	Pulsador verde completo	Complete green push button	1	1	1	1		
21	Z513004	Pulsador rojo completo	Complete red push button	1	1	1	1		
22	Z513010	Embellecedor adhesivo	Adhesive trim	1	1	1	-		

Зип Общепит

vsezip.ru

ZONA

PARTE ELECT

+7(812)987-08-81

MOD.		LAVAVAJILLAS DE CINTA		ZONA		PARTE ELECT			
ITEM	CODIGO	DENOMINACION	TEXTO	FI-2700	FI-4000	FI-6000	ECO-2700		
22	Z523010	Embellededor adhesivo	Adhesive trim	-	-	-	1		
23	Z513014	Frente cuadro eléctrico completo	Complete switchboard cover	1	1	1	1		
24	3715510	Canaleta unex 60x60x77 L=440	Unex channel 60x60x77 G=440	1	1	1	1		
24	3715510	Canaleta unex 60x60x77 L=470	Unex channel 60x60x77 G=470	1	1	1	1		
24	3715510	Canaleta unex 60x60x77 L=250	Unex channel 60x60x77 G=250	2	2	2	2		
25	Q162040	Tuerca hexagonal M-6	Hexagonal nut M-6	8	8	8	8		
26	Q262040	Arandela muelle A-6	Spring washer A-6	8	8	8	8		
27	Z513011	Soporte cuadro eléctrico	Switchboard support	1	1	1	1		
28	X183011	Contactador (resistencias tanque)	Contactador (tank resistors)	2	2	2	-		
29	X183011	Contactador (resistencias calderín)	Contactador (wash tub resistors)	3	3	3	3		
30	Z203050	Contactador (extractor o condensador)	Contactador (extractor or condenser)	1	1	1	1		
31	Z203050	Contactador (secado)	Contactador (dryer)	1	1	1	1		
32	Z203050	Contactador (recuperador energía)	Contactador (energy recovery)	1	1	1	1		
33	X183011	Contactador (resistencias calderín)	Contactador (wash tub resistors)	1	1	1	-		
34	Z123022	Temporizador (aclarado)	Timer (rinse)	1	1	1	1		
35	Z123022	Temporizador (secado)	Timer (dryer)	1	1	1	1		
36	Z213007	Contactador (bomba lavado 2)	Contactador (pump wash 2)	-	1	1	-		
37	Z213007	Contactador (bomba lavado 3)	Contactador (pump wash 3)	-	-	1	-		
38	Z213007	Contactador (puertas)	Contactador (doors)	1	1	1	1		
39	X183011	Contactador (resistencias secado)	Contactador (drying resistors)	1	1	1	1		
40	X183011	Contactador (resistencias tanque 2)	Contactador (tank resistors 2)	-	-	1	-		
41	X183011	Contactador (resistencias calderín)	Contactador (wash tub resistors)	1	1	1	-		
42	Z312941	Prensaestopas PG-42	Stuffing box PG-42	1	1	1	-		
42	R143010	Prensaestopas PG-36	Stuffing box PG-36	-	-	-	1		
43	Z312966	Soporte prensaestopas	Stuffing box support	1	1	1	1		
	Q262040	Arandela muelle A-6	Spring washer A-6	2	2	2	2		
	Q162040	Tuerca hexagonal M-6	Hexagonal nut M-6	2	2	2	2		
44	R693009	Guía contactor L=250	Contactador guide G=250	2	2	2	2		
44	R663055	Guía contactor L=120	Contactador guide G=120	5	5	5	5		

Зип Общепит

vsezip.ru

+7(812)987-08-81

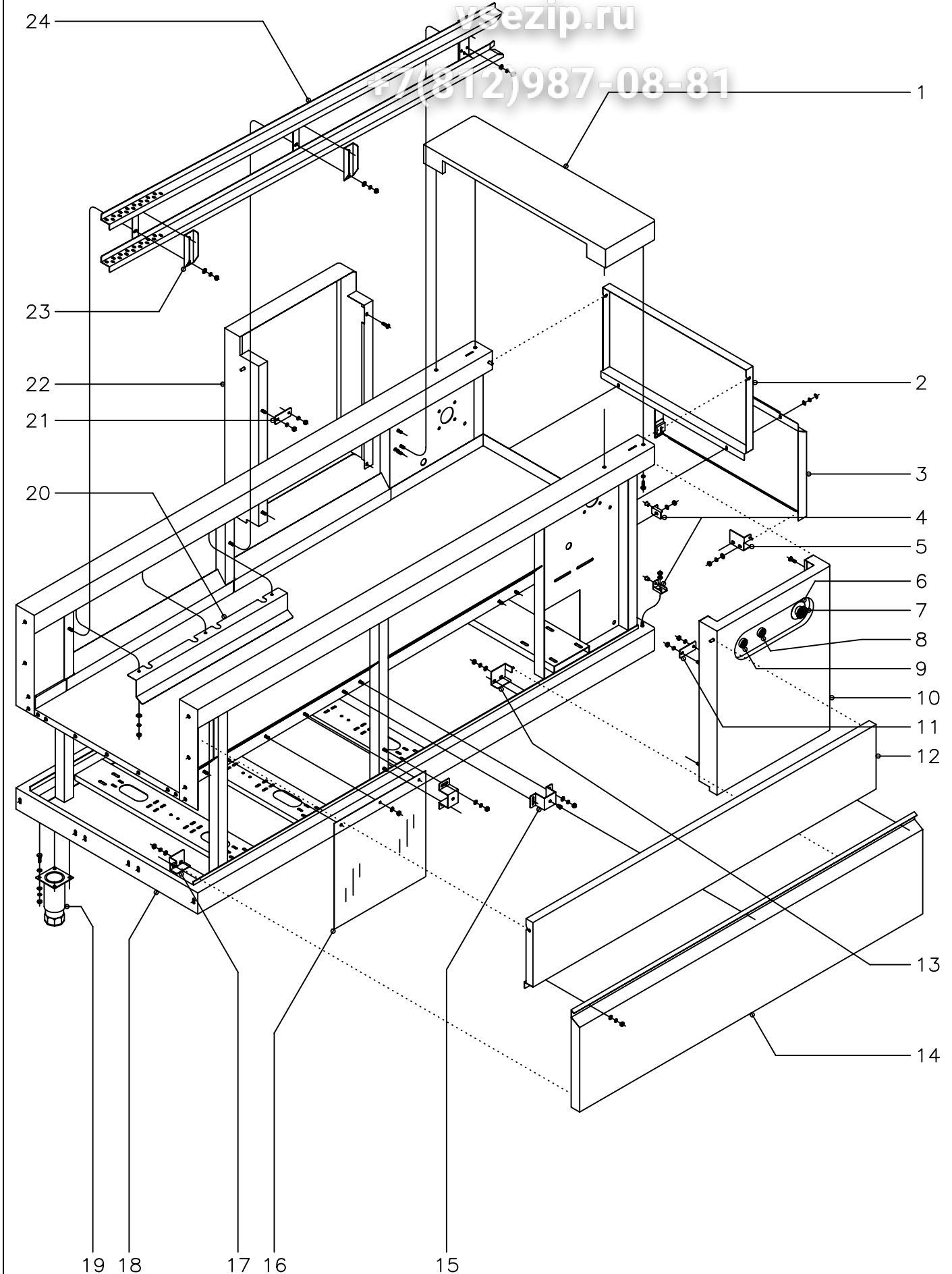

N plano C-1558	Firma 	Fecha 7-2004	Aparato LAVAVAJILLAS DE CINTA MODULO DE SALIDA	Lamina 14	Fagor Industrial S.Coop. FAGOR
-------------------	-----------	-----------------	--	--------------	---------------------------------------

Зип Общепит

vsezip.ru

+7(812)987-08-81

MOD.		LAVAVAJILLAS DE CINTA		ZONA		MODULO DE SALIDA			
ITEM	CODIGO	DENOMINACION	TEXTO	2700 I	2700 D	4000 I	4000 D		
1	Z512942	Tapa tope platos completa	Complete plate buffer lid	1	1	1	1		
	Q262040	Arandela muelle A-6	Spring washer A-6	4	4	4	4		
	Q012043	Tornillo hexagonal M-6x20	Hexagonal screw M-6x20	4	4	4	4		
2	Z512921	Panel lateral superior	Upper side panel	1	1	1	1		
3	Z512919	Panel lateral inferior completo	Complete lower side panel	1	1	1	1		
	Q302022	Arandela plana Ø16xØ6x1,2	Flat washer Ø16xØ6x10.2	2	2	2	2		
	Q262040	Arandela muelle A-6	Spring washer A-6	2	2	2	2		
	Q162040	Tuerca hexagonal M-6	Hexagonal nut M-6	2	2	2	2		
4	Z512962	Sujeción panel	Panel fastener	4	4	4	4		
	Q302022	Arandela plana Ø16xØ6x1,2	Flat washer Ø16xØ6x10.2	4	4	4	4		
	Q162040	Tuerca hexagonal M-6	Hexagonal nut M-6	4	4	4	4		
5	Z512958	Soporte giro izquierdo completo	Complete left turn support	1	1	1	1		
s/n	Z512956	Soporte giro derecho completo	Complete right turn support	1	1	1	1		
	Q302022	Arandela plana Ø16xØ6x1,2	Flat washer Ø16xØ6x10.2	4	4	4	4		
	Q262040	Arandela muelle A-6	Spring A-6 washer	4	4	4	4		
	Q162040	Tuerca hexagonal M-6	Hexagonal nut M-6	4	4	4	4		
6	Z513006	Etiqueta circular amarillo	Round yellow label	1	1	1	1		
7	Z513005	Interruptor de seta rojo	Round mushroom switch	1	1	1	1		
8	Z513004	Pulsador rojo completo	Complete red push button	1	1	1	1		
9	Z513003	Pulsador verde completo	Complete green push button	1	1	1	1		
10	Z512902	Panel portamandos salida comp.	Complete control panel outlet	1	-	1	-		
10	Z512907	Panel portamandos salida comp.	Complete control panel outlet	-	1	-	1		
	Q152004	Tornillo aplastado M-5x13	Screw M-5x13	2	2	2	2		
	Q221304	Remache redondo M-5	Round rivet M-5	4	4	4	4		
11	Z512961	Amarre panel	Panel anchoring	2	2	2	2		
	Q262040	Arandela muelle A-6	Spring washer A-6	4	4	4	4		
	Q162040	Tuerca hexagonal M-6	Hexagonal nut M-6	4	4	4	4		
12	Z512914	Panel superior salida	Upper panel outlet	2	2	2	2		
13	Z512956	Soporte giro derecho completo	Complete right turn support	2	2	2	2		

MOD.		LAVAVAJILLAS DE CINTA	ZONA	MODULO DE SALIDA			
ITEM	CODIGO	DENOMINACION	TEXTO	2700 I	2700 D	4000 I	4000 D
	Q302022	Arandela plana Ø16xØ6x1,2	Flat washer Ø16xØ6x10.2	4	4	4	4
	Q262040	Arandela muelle A-6	Spring washer A-6	4	4	4	4
	Q162040	Tuerca hexagonal M-6	Hexagonal nut M-6	4	4	4	4
14	Z512912	Panel inferior salida completo	Complete lower panel outlet	2	2	2	2
	Q302022	Arandela plana Ø16xØ6x1,2	Flat washer Ø16xØ6x10.2	6	6	6	6
	Q262040	Arandela muelle A-6	Spring washer A-6	6	6	6	6
	Q162040	Tuerca hexagonal M-6	Hexagonal nut M-6	6	6	6	6
15	Z512947	Soporte panel salida	Outlet panel support	8	8	8	8
	Q302022	Arandela plana Ø16xØ6x1,2	Flat washer Ø16xØ6x10.2	16	16	16	16
	Q262040	Arandela muelle A-6	Spring washer A-6	16	16	16	16
	Q162040	Tuerca hexagonal M-6	Hexagonal nut M-6	16	16	16	16
	Q221343	Remache hexagonal M-6	Hexagonal rivet M-6	8	8	8	8
16	Z513051	Cubierta componentes eléctricos	Electric components cover	1	1	1	1
	Q302022	Arandela plana Ø16xØ6x1,2	Flat washer Ø16xØ6x10.2	3	3	3	3
	Q162040	Tuerca hexagonal M-6	Hexagonal nut M-6	3	3	3	3
17	Z512958	Soporte giro izquierdo completo	Complete left turn support	2	2	2	2
	Q302022	Arandela plana Ø16xØ6x1,2	Flat washer Ø16xØ6x10.2	4	4	4	4
	Q262040	Arandela muelle A-6	Spring washer A-6	4	4	4	4
	Q162040	Tuerca hexagonal M-6	Hexagonal nut M-6	4	4	4	4
18	Z510440	Salida soldada completa	Complete welded outlet	1	1	1	1
19	X260151	Pata regulable	Ajustable leg	4	4	4	4
	Q012043	Tornillo hexagonal M-6x20	Hexagonal screw M-6x20	16	16	16	16
	Q302022	Arandela plana Ø16xØ6x1,2	Flat washer Ø16xØ6x10.2	32	32	32	32
	Q262040	Arandela muelle A-6	Spring washer A-6	16	16	16	16
	Q162040	Tuerca hexagonal M-6	Hexagonal nut M-6	16	16	16	16
20	Z510469	Protector fugas salida	Escape protector outlet	2	2	2	2
	Q302022	Arandela plana Ø16xØ6x1,2	Flat washer Ø16xØ6x10.2	6	6	6	6
	Q262040	Arandela muelle A-6	Spring washer A-6	6	6	6	6
	Q162040	Tuerca hexagonal M-6	Hexagonal nut M-6	6	6	6	6

Зип Общепит

vsezip.ru

(812) 987-08-81

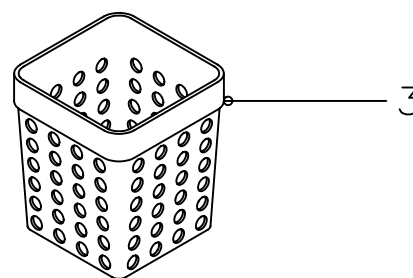
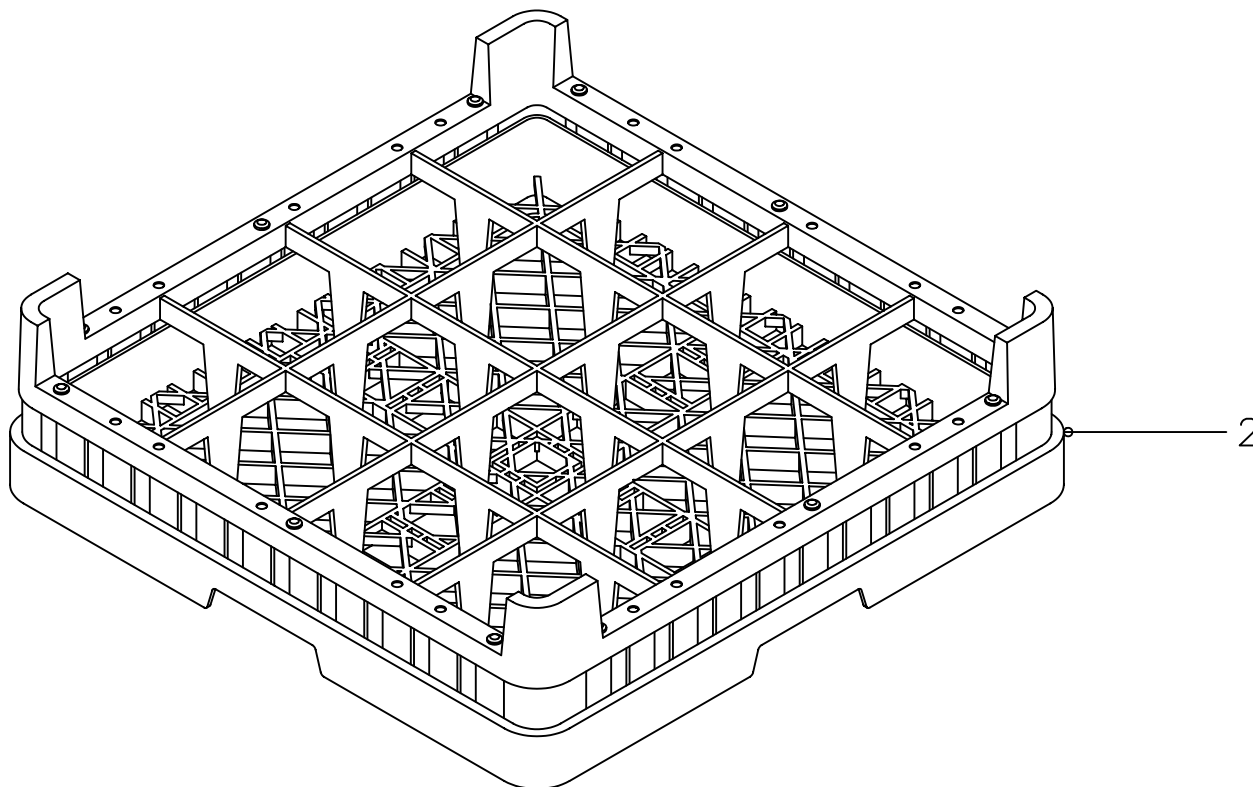
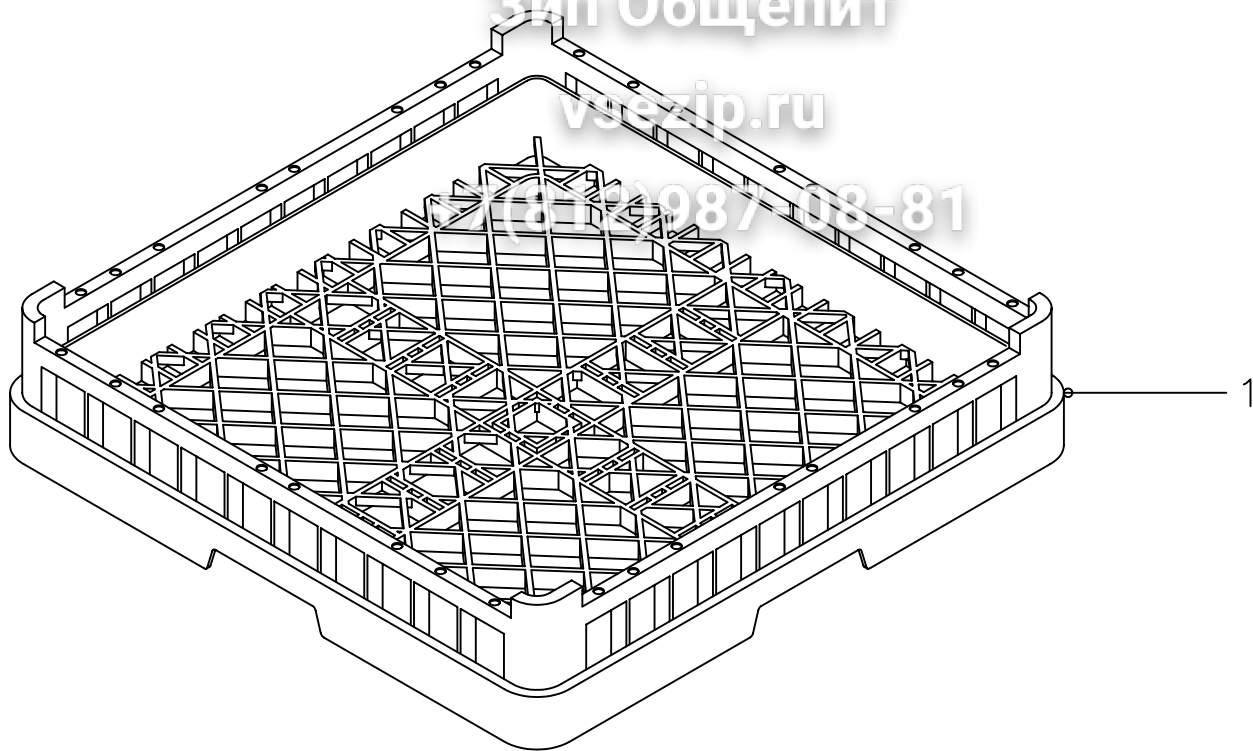

N plano

C-1559

Firma

Fecha

7-2004

Aparato

LAVAVAJILLAS DE CINTA

CESTILLOS

Lamina

15

Fagor Industrial S.Coop.

FAGOR



Ofate

Зип Общепит

vsezip.ru

+7(812)987-08-81

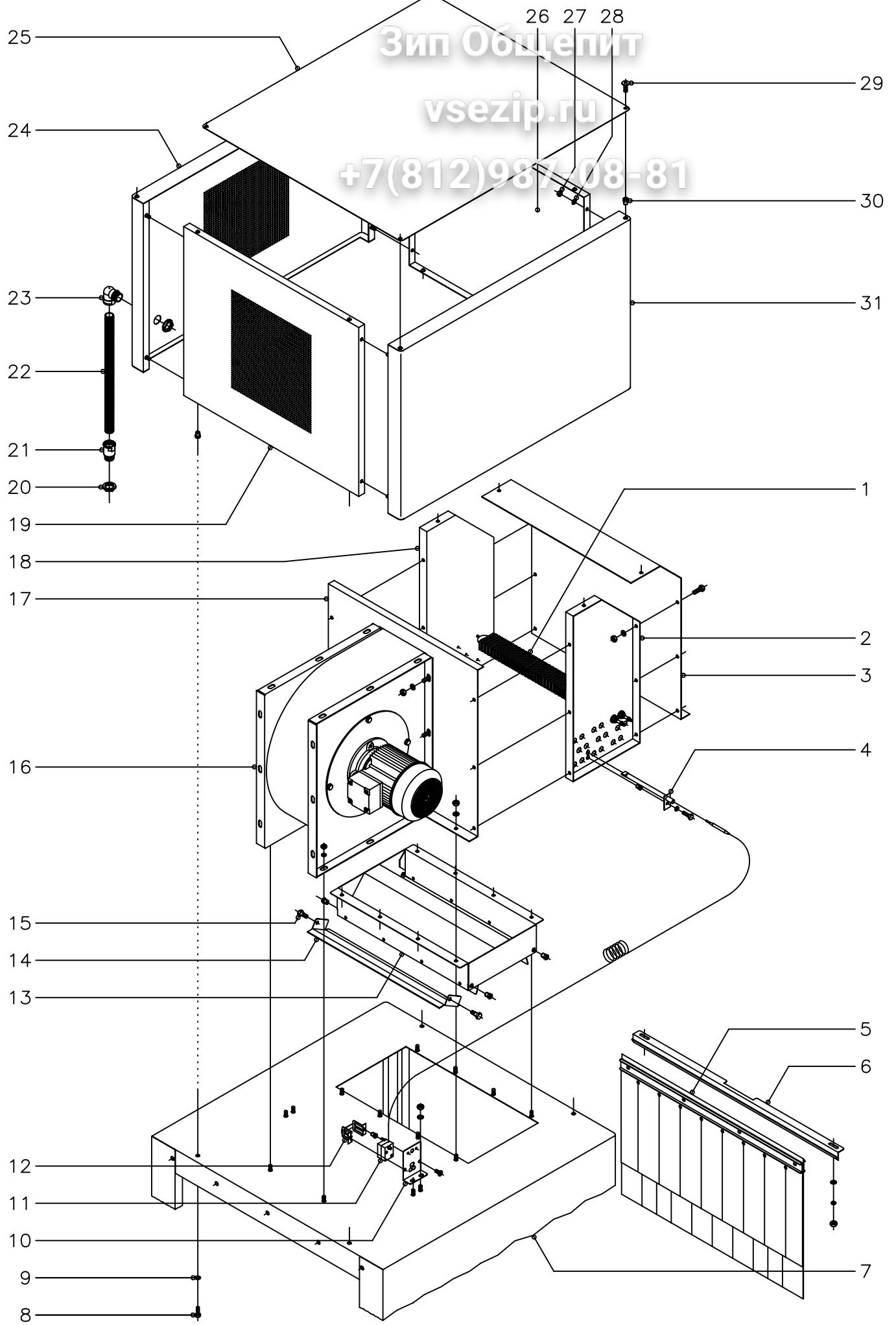

N plano
C-1560

Firma

Fecha
7-2004

Aparato
LAVAVAJILLAS DE CINTA
SECADO (800)

Lamina
16

Fagor Industrial S.Coop. **FAGOR**
Onate

Зип Ощепит

vsezip.ru

ZONA

MOD.

LAVAVAJILLAS DE CINTA

SECADO (800)

+7(812)987-08-81

ITEM	CODIGO	DENOMINACION	TEXTO	SECADO 800				
1	Z276391	Resistencia aletas 1500W., 230V.	Blade resistance 1500W., 230V.	9				
2	Z316319	Frontal caja resistencias	Resistor box front	1				
3	Z316316	Lateral izquierdo caja resistencias	Resistor box left side	1				
	Q012042	Tornillo hexagonal M-6x15	Hexagonal screw M-6x15	8				
	Q262040	Arandela muelle A-6	Spring washer A-6	8				
	Q162040	Tuerca hexagonal M-6	Hexagonal nut M-6	8				
4	Z276331	Vaina para bulbo termostato	Case for thermostat bulb	1				
	Q012042	Tornillo hexagonal M-6x15	Hexagonal screw M-6x15	1				
	Q262040	Arandela muelle A-6	Spring washer A-6	1				
	Q221343	Remache hexagonal M-6	Hexagonal rivet M-6	1				
5	Z276429	Cortina interior completa	Complete inner curtain	1				
6	Z510344	Sujeción cortina	Curtain fastening	1				
	Q232040	Arandela plana A-6	Flat washer A-6	2				
	Q262040	Arandela muelle A-6	Spring washer A-6	2				
	Q162040	Tuerca hexagonal M-6	Hexagonal nut M-6	2				
7	Z516301	Túnel de secado completo	Complete drying tunnel	1				
s/n	Z516314	Protector entrada secado	Drying inlet protector	2				
	Q262040	Arandela muelle A-6	Spring washer A-6	4				
	Q162040	Tuerca hexagonal M-6	Hexagonal nut M-6	4				
8	Q012042	Tornillo hexagonal M-6x15	Hexagonal screw M-6x15	4				
9	Q262040	Arandela muelle A-6	Spring washer A-6	4				
	Q221343	Remache hexagonal M-6	Hexagonal rivet M-6	4				
10	Z203047	SopORTE termostato	Thermostat support	1				
	Q232040	Arandela plana A-6	Flat washer A-6	2				
	Q162040	Tuerca hexagonal M-6	Hexagonal nut M-6	2				
11	Z213014	Termostato limitador	Limiter thermostat	1				
12	Z203060	Amarre limitador Tecasa	Tecasa limiter anchoring	1				
	Q221341	Remache hexagonal M-4	Hexagonal rivet M-4	2				
	Q152024	Tornillo avellanado M-4x8	Countersunk screw M-4x8	2				

Зип Общепит

vsezip.ru

+7(812)987-08-81

MOD.		LAVAVAJILLAS DE CINTA	ZONA	SECADO (800)			
ITEM	CODIGO	DENOMINACION	TEXTO	SECADO 800			
13	Z316386	Salida secado soldada	Welded dryer outlet	1			
	Q262040	Arandela muelle A-6	Spring washer A-6	8			
	Q162040	Tuerca hexagonal M-6	Hexagonal nut M-6	8			
14	Z316388	Tapa salida secado	Dryer outlet lid	2			
15	Q152046	Tornillo hexagonal con cuello	Hexagonal screw with neck	4			
	Q221343	Remache hexagonal M-6	Hexagonal rivet M-6	4			
16	Z316331	Ventilador centrifugo	Centrifugal ventilator	1			
	Q262040	Arandela muelle A-6	Spring washer A-6	6			
	Q162040	Tuerca hexagonal M-6	Hexagonal nut M-6	6			
17	Z316336	Lateral derecho caja resistencias	Resistor box right side	1			
18	Z316320	Posterior caja resistencias	Resistor box rear	1			
	Q012042	Tornillo hexagonal M-6x15	Hexagonal screw M-6x15	8			
	Q262040	Arandela muelle A-6	Spring washer A-6	8			
	Q162040	Tuerca hexagonal M-6	Hexagonal nut M-6	8			
19	Z516311	Lateral cubierta secado	Dryer side cover	1			
20	R023025	Contratuerca	Counter nut	2			
21	X713021	Racord	Joint	1			
22	3712300	Tubo PG-21 L=600	Pipe PG-21 G=600	1			
23	Z703006	Racord a 90°	Joint at 90°	1			
24	Z316324	Posterior cubierta completa	Complete rear cover	1			
25	Z516312	Tapa cubierta secado	Dryer cover lid	1			
26	Z516711	Lateral cubierta condensador	Condenser side cover	1			
27	Q162040	Tuerca hexagonal M-6	Hexagonal nut M-6	8			
28	Q262040	Arandela muelle A-6	Spring washer A-6	8			
29	Q152017	Tornillo amarre M-6x13	Anchoring screw M-6x13	4			
30	Q221343	Remache hexagonal M-6	Hexagonal rivet M-6	4			
31	Z316322	Anterior cubierta completa	Complete front cover	1			
s/n	Z316381	Cableado general secado	General dryer wiring	1			
s/n	Z316353	Cableado auxiliar secado	Dryer auxiliary wiring	1			

Зип Общепит

vsezip.ru

+7(812)987-08-81

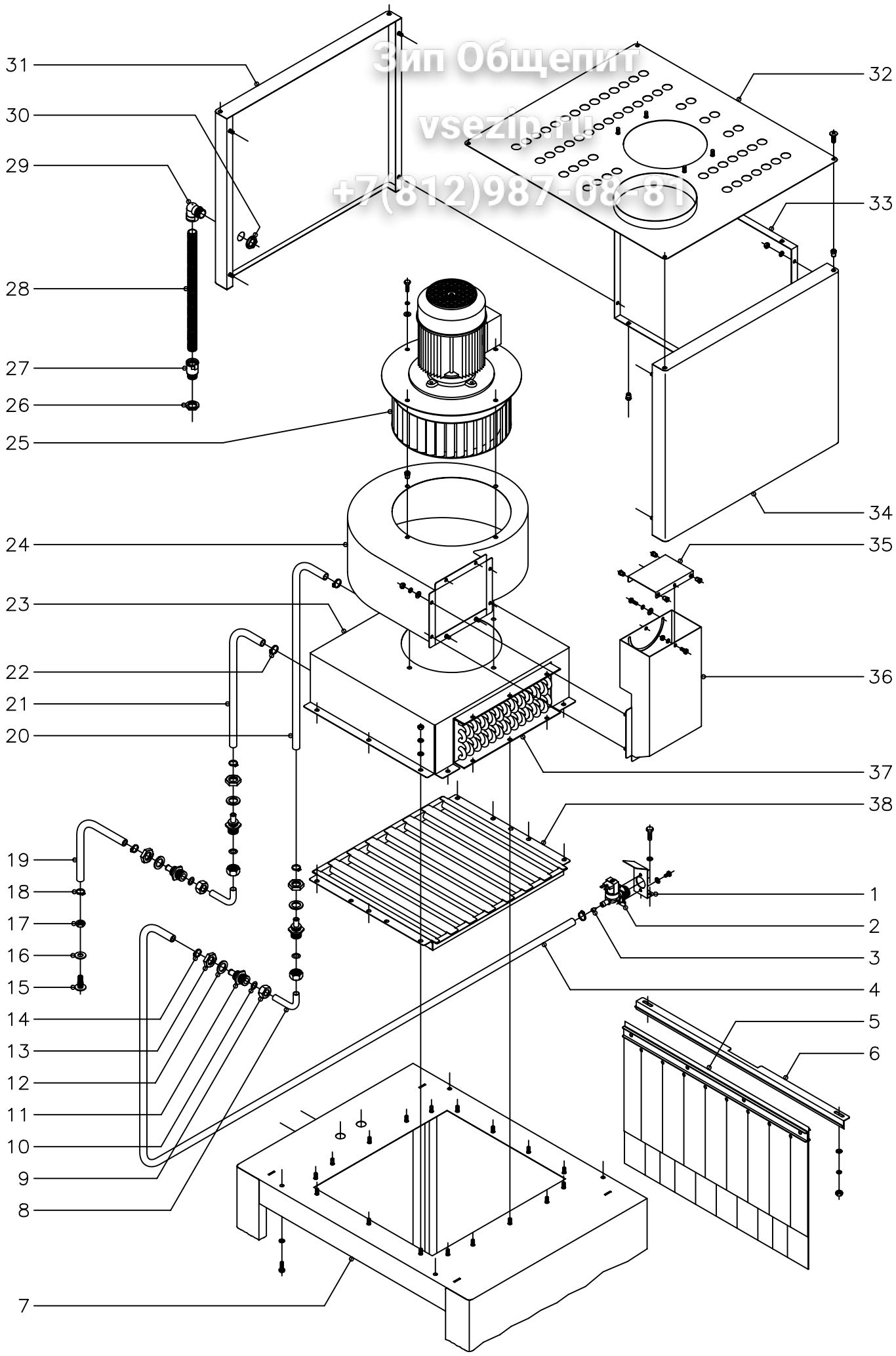

N plano C-1561	Firma 	Fecha 7-2004	Aparato LAVAVAJILLAS DE CINTA CONDENSADOR DE VAHOS	Lamina 17	Fagor Industrial S.Coop. FAGOR Oñate
-------------------	-----------	-----------------	--	--------------	--

Зип Общепит

vsezip.ru

ZONA

+7(812)987-08-81

MOD.		LAVAVAJILLAS DE CINTA		CONDENSADOR DE V	
ITEM	CODIGO	DENOMINACION	TEXTO	CONDENSADOR DE VAHOS	
1	Z201101	Escuadra amarre electrovalvula	Electrovalve anchoring bracket	1	
	Q012042	Tornillo hexagonal M-6x15	Hexagonal screw M-6x15	2	
	Q262040	Arandela muelle A-6	Spring washer A-6	2	
2	Z701135	Electrovalvula simple	Simple electrovalve	1	
	Q032021	Tornillo alomado M-4x10	Curved screw M-4x10	2	
	Q242020	Arandela abanico A-4	Fan shaped washer A-4	2	
3	P443042	Regulador caudal 3 l./min.	Flow regulator 3 G./min.	1	
4	3676900	Tube goma negra Ø17xØ10x5000	Black rubber pipe Ø17xØ10x5000	1	
5	Z276429	Cortina interior completa	Complete inner curtain	1	
6	Z510344	Sujeción cortina	Curtain fastening	1	
	Q232040	Arandela plana A-6	Flat washer A-6	2	
	Q262040	Arandela muelle A-6	Spring washer A-6	2	
	Q162040	Tuerca hexagonal M-6	Hexagonal nut M-6	2	
7	Z516701	Túnel condensador de vahos	Vapour condensing tunnel	1	
s/n	Z516704	Protector entrada condensador	Condenser inlet protector	2	
	Q262040	Arandela muelle A-6	Spring washer A-6	4	
	Q162040	Tuerca hexagonal M-6	Hexagonal nut M-6	4	
s/n	Z516712	Panel posterior condensador	Condenser rear panel	1	
	Q152004	Tornillo aplastado M-5x13	Screw M-5x13	2	
	Q221343	Remache hexagonal M-5	Hexagonal rivet M-5	2	
	Z512963	Soporte panel posterior	Rear panel support	2	
	Q262040	Arandela muelle A-6	Spring washer A-6	6	
	Q162040	Tuerca hexagonal M-6	Hexagonal nut M-6	6	
8	Z516709	Codo empalme condensador	Condenser elbow joint	2	
9	Q223108	Tuerca M-24x2,5	Nut M-24x20.5	4	
10	Q307063	Junta tórica Ø19,35xØ12,29xØ3,53	"O" ring Ø19,35xØ12,29xØ30.53	4	
11	Z271901	Pasamuros	Wire protection	4	
12	Q307032	Arandela junta Ø32xØ21x3	Joint washer Ø32xØ21x3	4	
13	Q223023	Tuerca hexagonal 5/8"	Hexagonal nut 5/8"	4	

Зип Общепит

vsezip.ru

ZONA

+7(812)987-08-81

MOD.		LAVAVAJILLAS DE CINTA		CONDENSADOR DE V		
ITEM	CODIGO	DENOMINACION	TEXTO	CONDENSADOR DE VAHOS		
14	Q881302	Abrazadera 12 - 20	Clamp 12 - 20	2		
15	Z600907	Toma de presión	Pressure point	1		
16	Z600908	Arandela plana Ø26xØ12,5x2	Flat washer Ø26xØ12,5x2	1		
17	Q223013	Tuerca hexagonal M-12	Hexagonal nut M-12	1		
18	Q881302	Abrazadera 12 - 20	Clamp 12 - 20	2		
19	3676900	Tubo goma negra Ø17xØ10x2000	Black rubber pipe Ø17xØ10x2000	1		
20	3676900	Tubo goma negra Ø17xØ10x600	Black rubber pipe Ø17xØ10x600	1		
21	3676900	Tubo goma negra Ø17xØ10x300	Black rubber pipe Ø17xØ10x300	1		
22	Q881302	Abrazadera 12 - 20	Clamp 12 - 20	4		
23	Z276741	Cubierta batería	Battery cover	1		
	Q232040	Arandela plana A-6	Flat washer A-6	10		
	Q262040	Arandela muelle A-6	Spring washer A-6	10		
	Q162040	Tuerca hexagonal M-6	Hexagonal nut M-6	10		
24	Z276742	Cubierta ventola completa	Complete ventilator cover	1		
25	Z276760	Ventilador centrifugo	Centrifugal ventilator	1		
	Q012042	Tornillo hexagonal M-6x15	Hexagonal screw M-6x15	8		
	Q262040	Arandela muelle A-6	Spring washer A-6	8		
	Q302022	Arandela plana Ø16xØ6x1,2	Flat washer Ø16xØ6x10.2	8		
	Q221343	Remache hexagonal M-6	Hexagonal rivet M-6	8		
26	R023025	Contratuerca	Counter nut	1		
27	X713021	Racord	Joint	1		
28	3712300	Tubo PG-21 L=800	Pipe PG-21 G=800	1		
29	Z703006	Racord a 90°	Joint at 90°	1		
30	R023025	Contratuerca	Counter nut	1		
31	Z276752	Posterior cubierta completa	Complete rear cover	1		
	Q262040	Arandela muelle A-6	Spring washer A-6	4		
	Q162040	Tuerca hexagonal M-6	Hexagonal nut M-6	4		
32	Z516721	Tapa cubierta completa	Complete cover lid	1		
	Q152017	Tornillo amarre M-6x13	Anchoring screw M-6x13	4		

Зип Общепит

vsezip.ru

ZONA

MOD.

LAVAVAJILLAS DE CINTA

CONDENSADOR DE VAHOS

+7(812)987-08-81

ITEM	CODIGO	DENOMINACION	TEXTO	CONDENSADOR DE VAHOS			
	Q221343	Remache hexagonal M-6	Hexagonal rivet M-6	4			
33	Z516711	Lateral cubierta condensador	Condenser side cover	2			
	Q221343	Remache hexagonal M-6	Hexagonal rivet M-6	4			
	Q012042	Tornillo hexagonal M-6x15	Hexagonal screw M-6x15	4			
	Q262040	Arandela muelle A-6	Spring washer A-6	4			
34	Z276342	Anterior cubierta condensador	Condenser front cover	1			
	Q262040	Arandela muelle A-6	Spring washer A-6	4			
	Q162040	Tuerca hexagonal M-6	Hexagonal nut M-6	4			
35	Z276755	Regulador salida aire	Air outlet regulator	1			
	Q152047	Tornillo cilindrico con cuello M-5	Cylindrical screw with neck M-5	2			
	Q262030	Arandela muelle A-5	Spring washer A-5	2			
	Q162030	Tuerca hexagonal M-5	Hexagonal nut M-5	2			
	Q221343	Remache hexagonal M-5	Hexagonal rivet M-5	4			
	Q302022	Arandela plana Ø16xØ6x1,2	Flat washer Ø16xØ6x10.2	1			
	Q262030	Arandela muelle A-5	Spring washer A-5	1			
	Q012032	Tornillo hexagonal M-5x15	Hexagonal screw M-5x15	1			
36	Z276746	Salida aire completa	Complete air outlet	1			
	Q232040	Arandela plana A-6	Flat washer A-6	8			
	Q262040	Arandela muelle A-6	Spring washer A-6	8			
	Q162040	Tuerca hexagonal M-6	Hexagonal nut M-6	8			
37	Z276762	Batería completa	Complete battery	1			
	Q232040	Arandela plana A-6	Flat washer A-6	12			
	Q262040	Arandela muelle A-6	Spring washer A-6	12			
	Q162040	Tuerca hexagonal M-6	Hexagonal nut M-6	12			
	Q012042	Tornillo hexagonal M-6x15	Hexagonal screw M-6x15	6			
38	Z276734	Rejilla aspiración vahos completa	Complete vapour extractor rack	1			
s/n	Z316702	Cableado condensador	Condenser wiring	1			

400V 3N~

FI - 2700

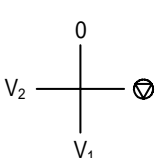
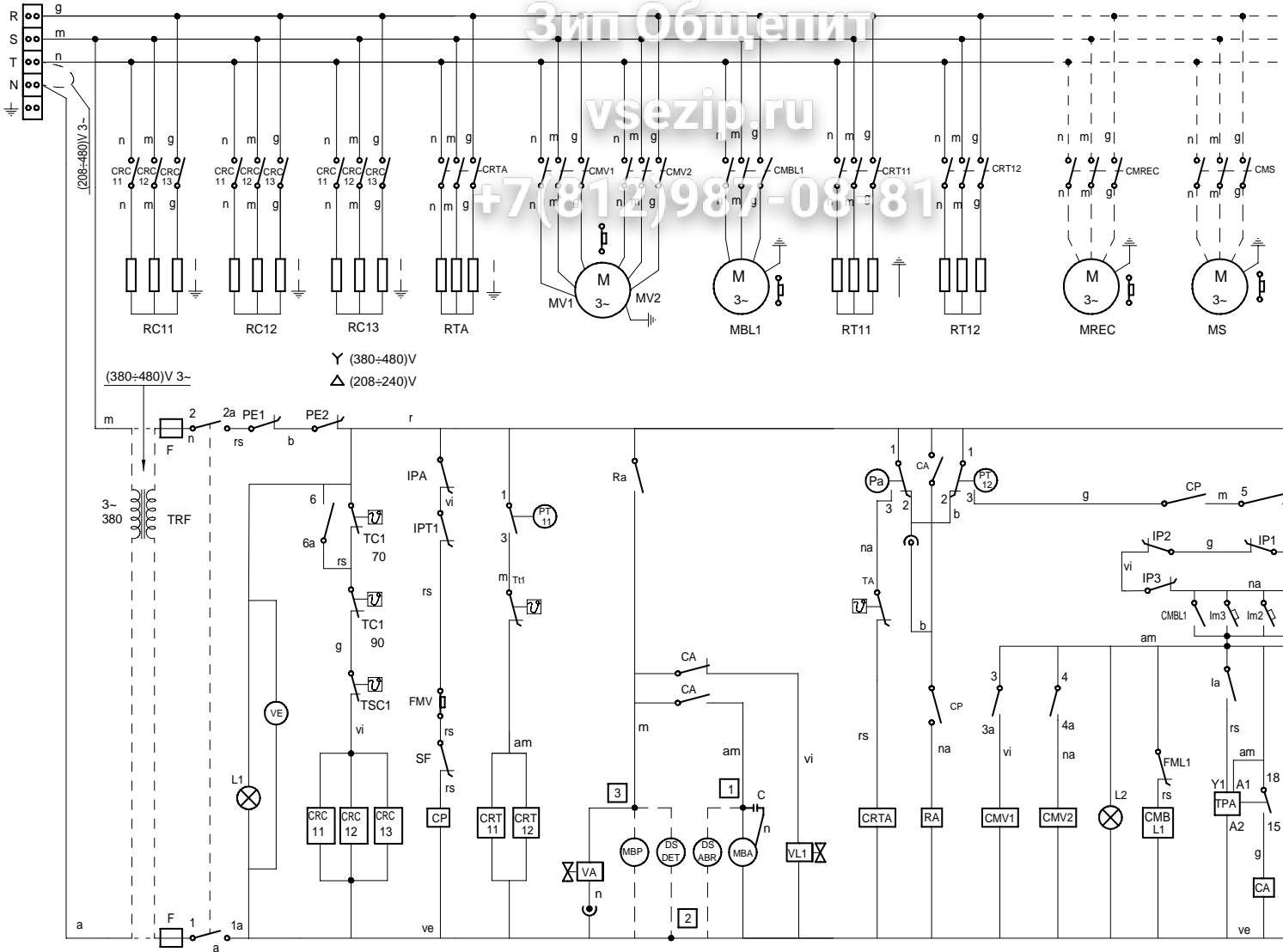

IG	1 1a	2 2a	3 3a	4 4a	5 5a	6 6a
0						
	X	X				
V ₁	X	X	X		X	X
V ₂	X	X		X	X	X

	ESPAÑOL	FRANÇAIS	ENGLISH	DEUTSCH	ITALIANO
COLOR	<i>COLOR</i>	<i>COULEUR</i>	<i>COLOUR</i>	<i>FARBEN</i>	<i>COLORE</i>
a =	Azul	Bleu	Blue	Blau	Blu
am =	Amarillo	Jaune	Yellow	Gelb	Giallo
am/ve =	Amarillo/verde	Jaune / vert	Yellow / green	Gelb/grün	Giallo/verde
b =	Bianco	Blanc	White	Weiß	Bianco
g =	Gris	Gris	Grey	Grau	Grigio
m =	Marrón	Marron	Brown	Braun	Marrone

	ESPAÑOL	FRANÇAIS
COLOR	<i>COLOR</i>	<i>COULEUR</i>
n =	Negro	Noir
na =	Naranja	Orange
r =	Rojo	Rouge
rs =	Rosa	Rose
ve =	Verde	Vert
vi =	Violeta	Violet

400V 3N~

FI - 4000

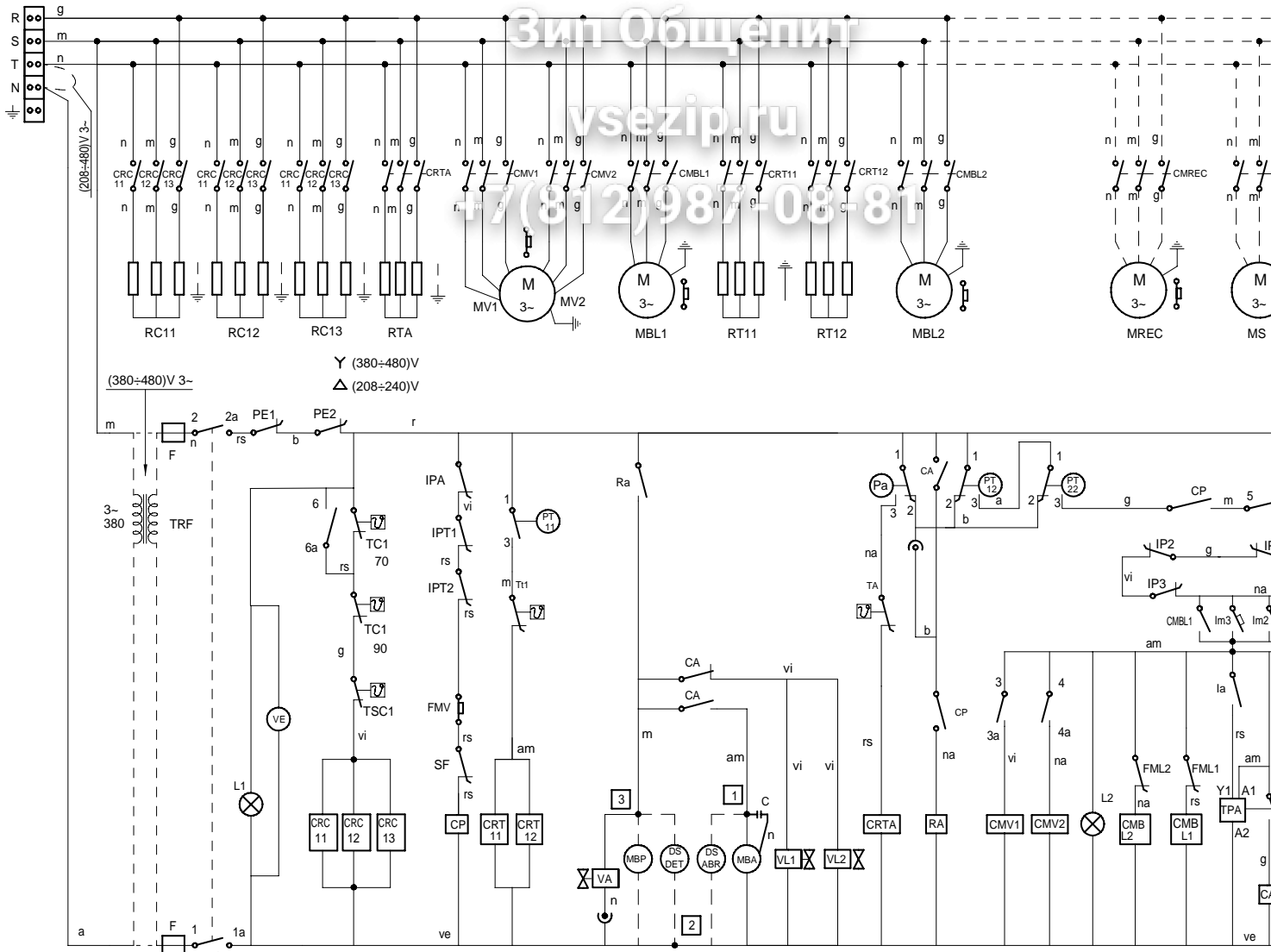

Зип Общепит
vsezip.ru
77(812)987-08-81

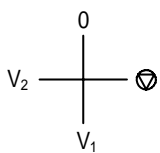

IG	1 1a	2 2a	3 3a	4 4a	5 5a	6 6a
0						
V ₁	X	X	X		X	X
V ₂	X	X		X	X	X

	ESPAÑOL COLOR	FRANCAIS COULEUR	ENGLISH COLOUR	DEUTSCH FARBEN	ITALIANO COLORE		ESPAÑOL COLOR
a	= Azul	Bleu	Blue	Blau	Blu	n	= Negro
am	= Amarillo	Jaune	Yellow	Gelb	Giallo	na	= Naranja
am/ve	= Amarillo/verde	Jaune / vert	Yellow / green	Gelb/grün	Giallo/verde	r	= Rojo
b	= Blanco	Blanc	White	Weiß	Bianco	rs	= Rosa
g	= Gris	Gris	Grey	Grau	Grigio	ve	= Verde
m	= Marrón	Marron	Brown	Braun	Marrone	vi	= Violeta

400V 3N~

FI - 6000

Зип Общепит

vsezip.ru

+7(812)987-08-81

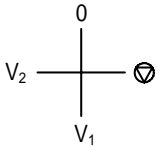
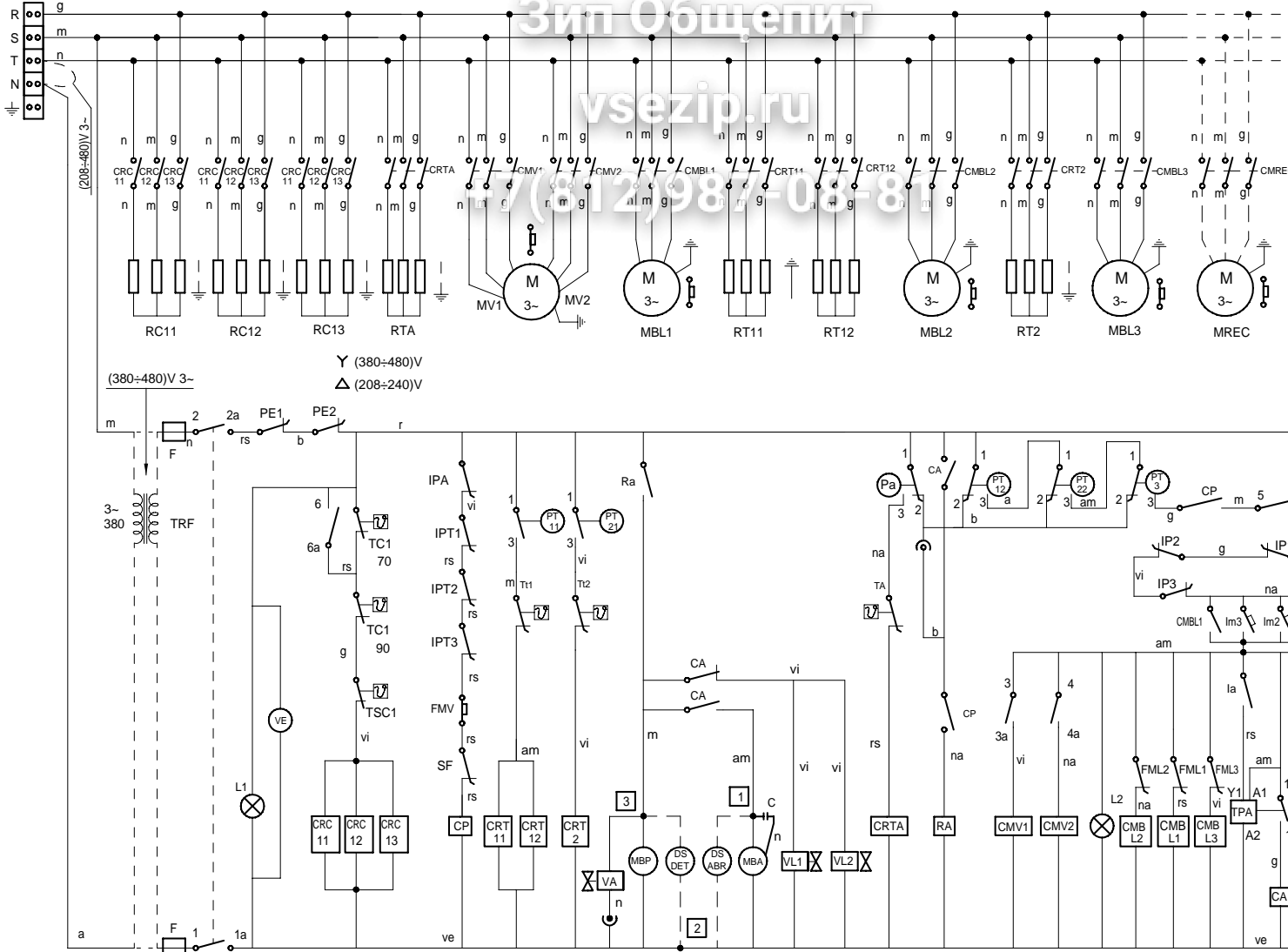

IG	1 1a	2 2a	3 3a	4 4a	5 5a	6 6a
0						
V1	X	X	X		X	X
V2	X	X		X	X	X

	ESPAÑOL	FRANÇAIS	ENGLISH	DEUTSCH	ITALIANO		ESPAÑOL
COLOR	COLOR	COULEUR	COLOUR	FARBEN	COLORE	COLOR	COLOR
a =	Azul	Bleu	Blue	Blau	Blu	n =	Negro
am =	Amarillo	Jaune	Yellow	Gelb	Giallo	na =	Naranja
am/ve =	Amarillo/verde	Jaune / vert	Yellow / green	Gelb/grün	Giallo/verde	r =	Rojo
b =	Blanco	Blanc	White	Weiß	Bianco	rs =	Rosa
g =	Gris	Gris	Grey	Grau	Grigio	ve =	Verde
m =	Marrón	Marron	Brown	Braun	Marrone	vi =	Violeta

400V 3N~

ECO-2700

Зип Общепит

vsezip.ru

+7(812)987-08-81

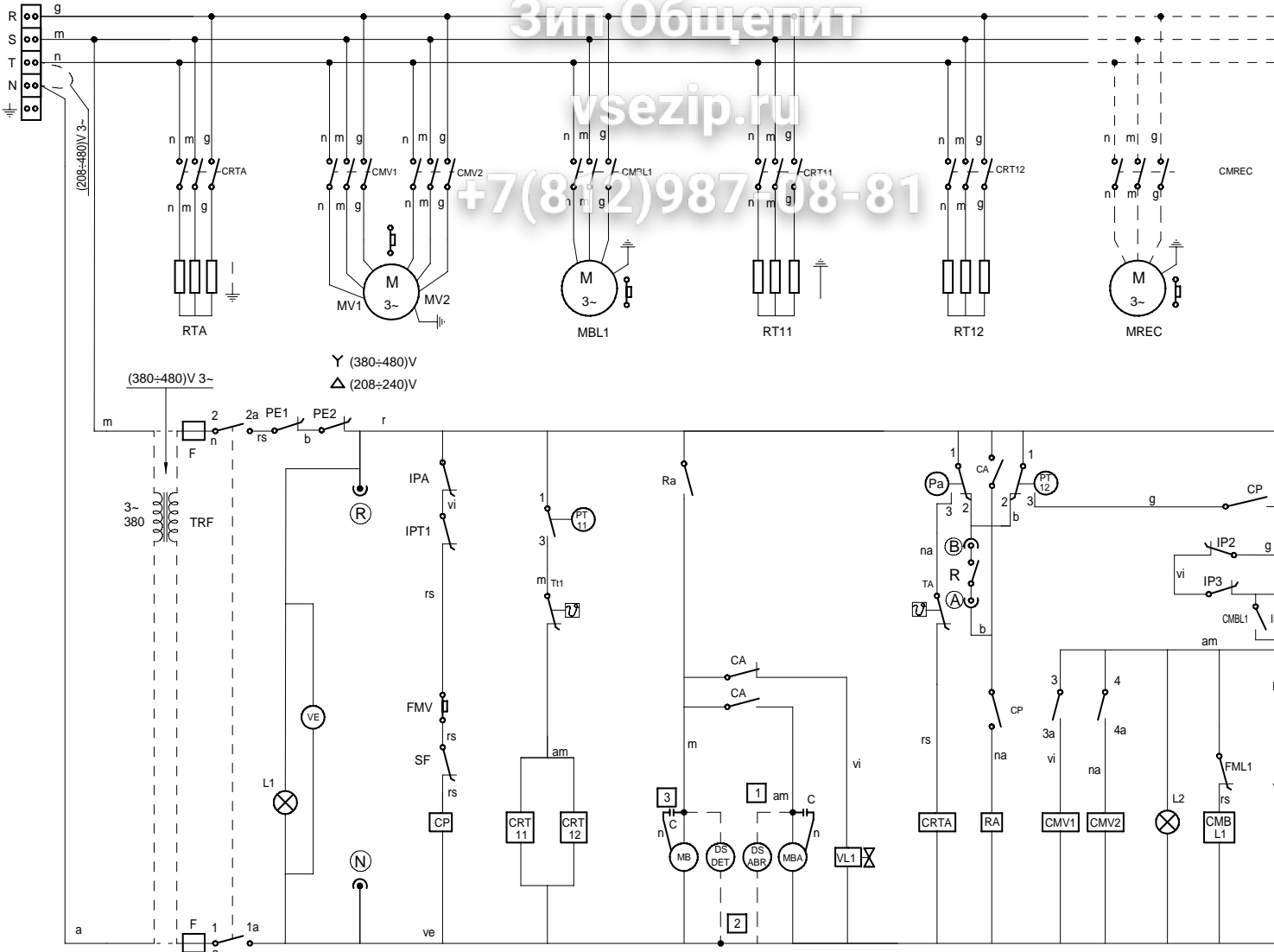

Y (380÷480)V
Δ (208÷240)V

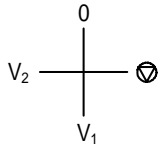

IG	1 1a	2 2a	3 3a	4 4a	5 5a	6 6a
0						
⊕	X	X				
V ₁	X	X	X		X	X
V ₂	X	X		X	X	X

COLOR	ESPAÑOL	FRANÇAIS	ENGLISH	DEUTSCH	ITALIANO	COLOR	ESPAÑOL
a =	Azul	Bleu	Blue	Blau	Blu	n =	Negro
am =	Amarillo	Jaune	Yellow	Gelb	Giallo	na =	Naranja
am/ve =	Amarillo/verde	Jaune / vert	Yellow / green	Gelb/grün	Giallo/verde	r =	Rojo
b =	Bianco	Blanc	White	Weiß	Bianco	rs =	Rosa
g =	Gris	Gris	Grey	Grau	Grigio	ve =	Verde
m =	Marrón	Marron	Brown	Braun	Marrone	vi =	Violeta

400V 3N~

ECO-4000

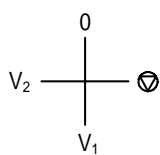
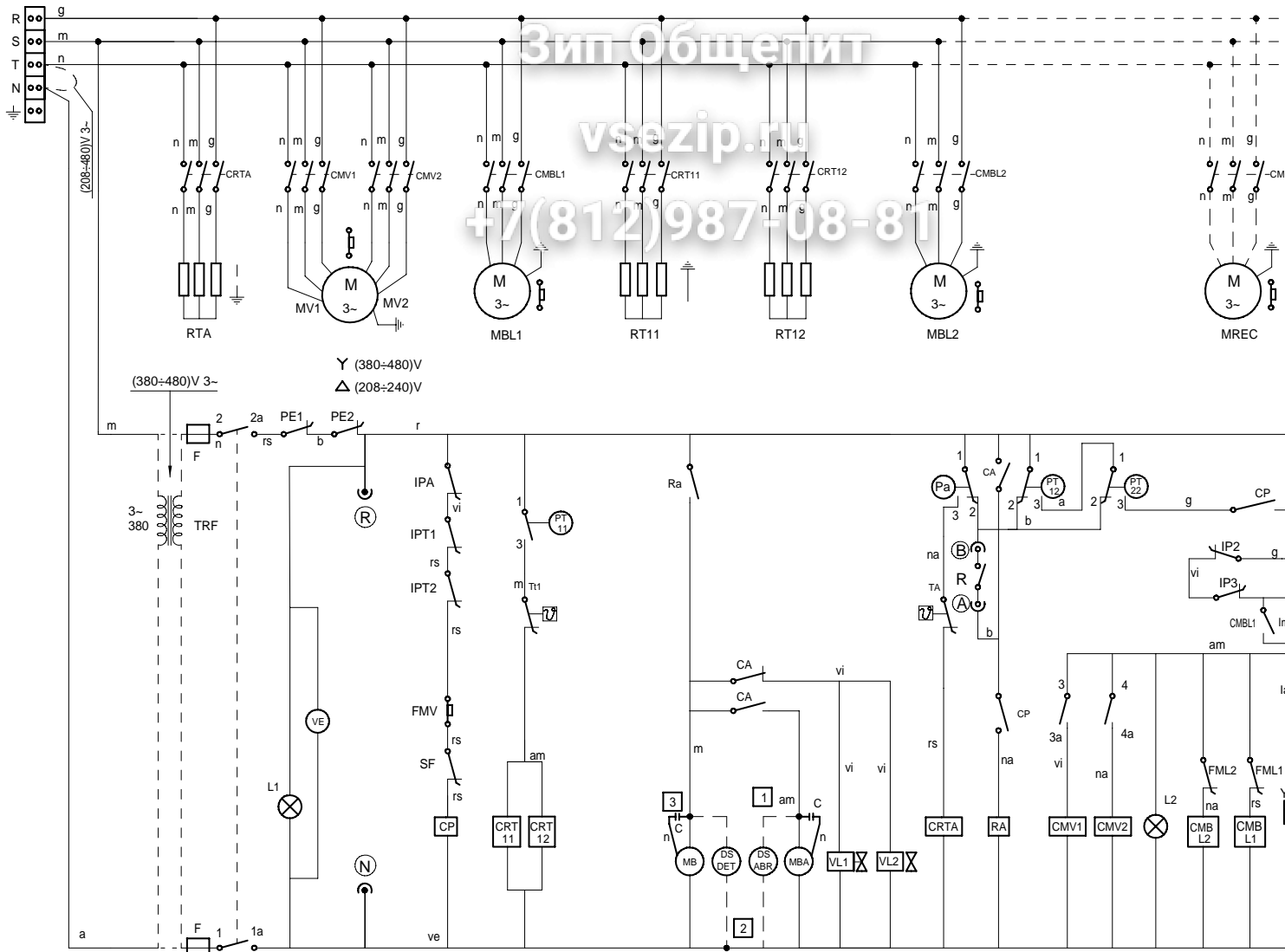

IG	1 1a	2 2a	3 3a	4 4a	5 5a	6 6a
0						
	X	X				
V ₁	X	X	X		X	X
V ₂	X	X		X	X	X

	ESPAÑOL	FRANÇAIS	ENGLISH	DEUTSCH	ITALIANO		ESPAÑOL
COLOR	COLOR	COULEUR	COLOUR	FARBEN	COLORE	COLOR	COLOR
a =	Azul	Bleu	Blue	Blau	Blu	n =	Negro
am =	Amarillo	Jaune	Yellow	Gelb	Giallo	na =	Naranja
am/ve =	Amarillo/verde	Jaune / vert	Yellow / green	Gelb/grün	Giallo/verde	r =	Rojo
b =	Blanco	Blanc	White	Weiß	Bianco	rs =	Rosa
g =	Gris	Gris	Grey	Grau	Grigio	ve =	Verde
m =	Marrón	Marron	Brown	Braun	Marrone	vi =	Violeta

400V 3N~

ECO-6000

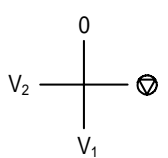
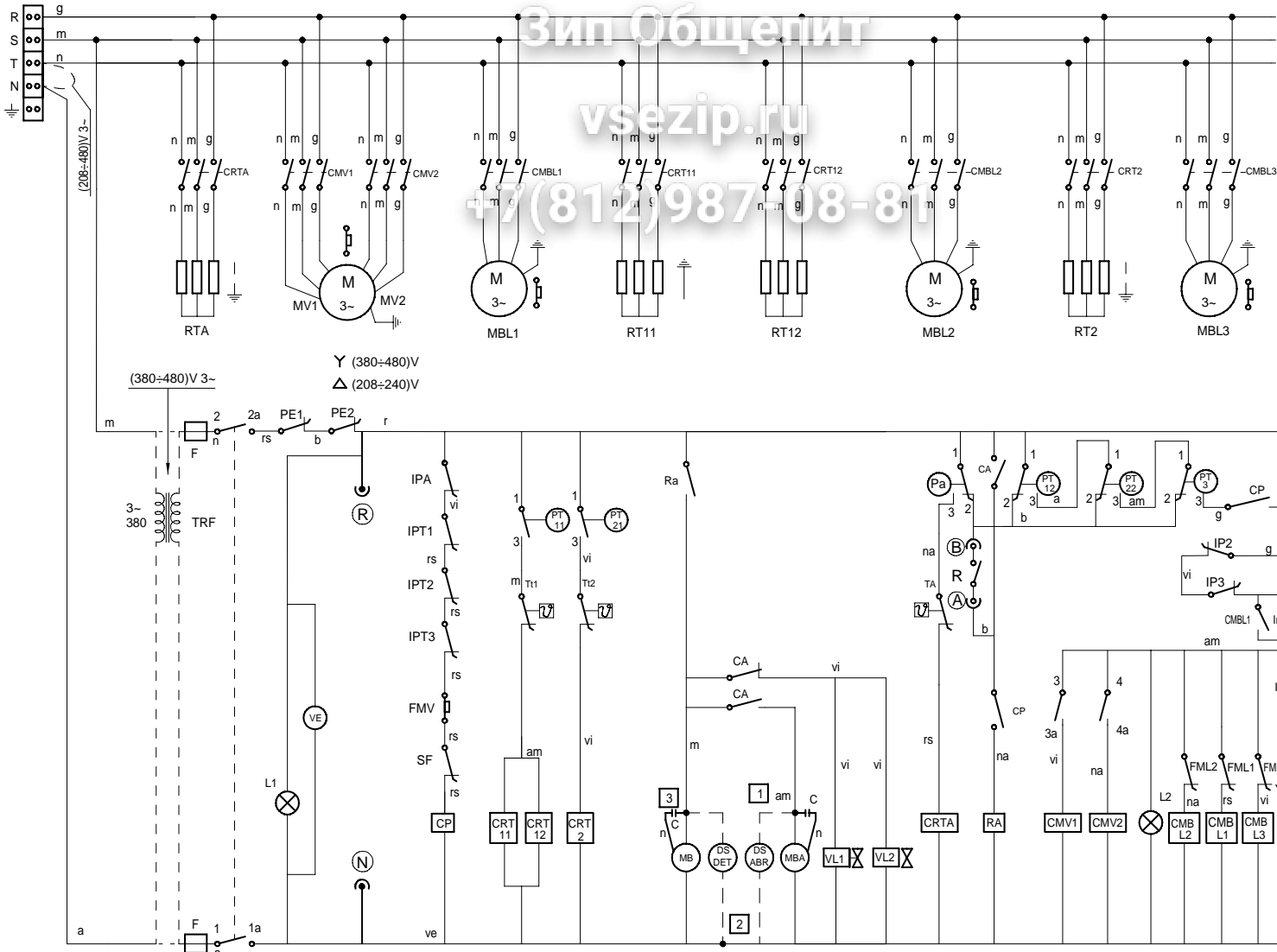

IG	1 1a	2 2a	3 3a	4 4a	5 5a	6 6a
0						
V ₁	X	X			X	X
V ₂	X	X		X	X	X

	ESPAÑOL	FRANÇAIS	ENGLISH	DEUTSCH	ITALIANO		ESPAÑOL
COLOR	COLOR	COULEUR	COLOUR	FARBEN	COLORE	COLOR	COLOR
a =	Azul	Bleu	Blue	Blau	Blu	n =	Negro
am =	Amarillo	Jaune	Yellow	Gelb	Giallo	na =	Naranja
am/ve =	Amarillo/verde	Jaune / vert	Yellow / green	Gelb/grün	Giallo/verde	r =	Rojo
b =	Bianco	Blanc	White	Weiß	Bianco	rs =	Rosa
g =	Gris	Gris	Grey	Grau	Grigio	ve =	Verde
m =	Marrón	Marron	Brown	Braun	Marrone	vi =	Violeta

ESPAÑOL
 (A)(B) = Puntos de conexión con R
 (C) = Puntos de conex. 160/200 sin secado ni condensador
 C,C1,C2 = Condensador
 CA = Rele auxiliar aclarado
 CMBL 1/2/3 = Contactor bomba lavado 1/2/3
 CMBPL = Contactor bomba prelavado
 CMEV = Contactor motor extractor
 CMS = Contactor motor secado
 CMV 1/2 = Contactor avance 1/2
 CMREC = Contactor motor recuperador
 CRC 11/12/13/21/22 = Contactor calentamiento calderin
 CRS = Contactor resistencia secado
 CRTA = Contactor calentamiento aclarado
 CRT2 = Contactor calentamiento tanque 2
 CRT11/12 = Contactor calentamiento tanque 1
 CP = Rele puerta
 DS.ABR = Dosificador abrillantador
 DS.DET.= Dosificador detergente
 F = Fusible
 FMEV = Rele termico motor extractor
 FML1/2/3 = S. Termico bomba lavado 1/2/3
 FMS = Rele termico motor secado
 FMREC = Rele termico motor recuperador
 FMV = S. Termica motor avance
 Ia = Micro aclarado
 IG = Interruptor general
 IL = Micro lavado
 Im1/2/3 = Pulsador de marcha
 IPA = Micro puerta aclarado
 IP1/2/3 = Pulsador de parada
 IPPL = Micro puerta prelavado
 IPT1/2/3 = Micro puerta tanque 1/2/3
 L1 = Piloto de encendido
 L2 = Piloto marcha
 MB = Bomba de llenado y aclarado
 MBA = Bomba aclarado
 MBL1/2/3 = Bomba lavado 1/2/3
 MBP = Bomba de presion
 MBPL = Bomba prelavado
 MEV = Motor extractor vahos
 MREC = Motor recuperador
 MS = Motor secado
 MV = Motor avance
 Pa = Presostato aclarado
 PE1/2 = Parada de emergencia
 PPL = Presostato prelavado
 PT11 = Presostato lavado 1 calentamiento
 PT12 = Presostato lavado 1 llenado
 PT21 = Presostato lavado 2 calentamiento
 PT2/PT22 = Presostato lavado 2 llenado
 PT3 = Presostato lavado 3 llenado
 R = Rele de Generador A.C.
 (R)(N) = Toma de alimentacion Generador A.C.
 Ra = Rele auxiliar aclarado y llenado
 RC11/12/13/21/22 = Resistencia calderin
 RS = Resistencia secado
 RTA = Resistencia calentamiento aclarado
 RT2 = Resistencia tanque 2
 RT11/12 = Resistencia tanque 1
 SF = Micro fin recorrido
 TA = Termostato aclarado
 TC, 1/2 = Termostato calderin
 TPA = Temporizador Aclarado
 TPT = Temporizador inicio
 TPS = Temporizador secado
 TREC = Termostato recuperador
 TRF = Transformador
 TS = Termostato secado
 TSC, 1/2 = Limitador calderin
 Tt1/2 = Termostato tanque 1/2
 VA = Electrovalvula llenado y aclarado
 VE = Ventilador cuadro electrico
 VEV = Electrovalvula condensacion vahos
 VL1/2 = Electrovalvula llenado tanque
 VG = Electrovalvula general
 VREC = Electrovalvula salida

FRANÇAIS
 Points de conexión R
 Points de conexión 160/200 sans sechege ni condensateur
 Condensateur
 Relais auxilier rinçage
 Contacteur pompe lavage 1/2/3
 Contacteur pompe prelavage
 Contacteur moteur extracteur
 Contacteur moteur sechage
 Contacteur avance 1/2
 Contacteur moteur recuperateur
 Contacteur chauff. surchauffeur
 Contacteur resistances sechage
 Contacteur chauffage rinçage
 Contacteur chauffage cuve 2
 Contacteur chauffage cuve 1
 Relais porte
 Dosseur de tensoactif
 Dosseur de detergent
 Fusible
 Relais termique moteur extracteur
 S. Termique pompe lavage 1/2/3
 Relais termique moteur sechage
 Relais termique moteur recuperateur
 S. Termica moteur avance
 Micro rinçage
 Interrupteur general
 Micro lavage
 Bouton marche
 Micro porte rinçage
 Bouton arrêt
 Micro porte prelavage
 Micro porte cuve 1/2/3
 Voyant fonctionnement
 Voyant demarrage
 Pompe remplissage rinçage
 Pompe rinçage
 Pompe lavage 1/2/3
 Pompe de pression
 Pompe prelavage
 Moteur extracteur vapeur
 Moteur recuperateur
 Moteur sechage
 Moteur avance
 Pressostat rinçage
 Arrêt d'urgence
 Pressostat prelavage
 Pressostat lavage 1 chauffage
 Pressostat lavage 1 remplissage
 Pressostat lavage 2 chauffage
 Pressostat lavage 2 remplissage
 Pressostat lavage 3 remplissage
 Relais du Generateur
 Alimentation generateur
 Relais auxilier rinçage remplissage
 Resistance surchauffeur
 Resistance sechage
 Resistance chauffage rinçage
 Resistance cuve 2
 Resistance cuve 1
 Micro fin de coourse
 Thermostat de rinçage
 Thermostat surchauffeur
 Temporisateur rinçage
 Temporisateur demarrage
 Temporisateur sechage
 Thermostate recuperateur
 Transformateur
 Thermostat sechage
 Thermostat limiteur surchauffeur
 Thermostat cuve 1/2
 Electrovanne remplissage rinçage
 Ventilateur tableau electricque
 Electrovanne condenseur vapeur
 Electrovanne remplissage cuve
 Electrovanne general
 Electrovanne demarrage

ENGLISH
 Conection point with R
 Connection points 160/200 without drying nor condenser
 Condenser
 Rinse auxiliary relay
 Wash pump contactor 1/2/3
 Pre-Wash pump contactor
 Exhaust motor contactor
 Drying motor contactor
 Advance contactor 1/2
 Motor recover contactor
 Boiler heating contactor
 Drying heating element contactor
 Rinse heating contactor
 Tank heating contactor 2
 Tank heating contactor 1
 Door relay
 Rinse doser
 Detergent doser
 Fuse
 Thermic switch exhaust motor relay
 Thermic switch pump 1/2/3
 Drying motor thermic relay
 Thermic switch recover motor
 Thermic switch rack pulling motor
 Rinse microswitch
 Main switch
 Wash microswitch
 On pushbutton
 Rinse door microswitch
 Off pushbutton
 Pre-wash door microswitch
 Tank door microswitch 1/2/3
 Operation light
 Start light
 Fill and rinse pump
 Rinse pump
 Wash pump 1/2/3
 Pressure pump
 Pre-wash pump
 Exhaust steam motor
 Recover motor
 Drying motor
 Motor advance
 Rinse level switch
 Emergency stop
 Pre-wash level switch
 Wash level 1 and heating switch
 Wash level 1 and fill switch
 Wash level 2 and heating switch
 Wash level 2 and fill switch
 Wash 3 fill pressostat
 Generator rele
 Water heater feeding
 Rinse and fill auxiliary relay
 Boiler heating element
 Drying heating element
 Rinse heating heater
 Tank heater 2
 Tank heater 1
 Safety end switch
 Rinse thermostat
 Boiler thermostat
 Rinsing timer
 Start timer
 Drying timer
 Recover thermostat
 Trasformer
 Drying thermostat
 Boiler Hi-limit thermostat
 Tank thermostat 1/2
 Fill and rinse valve
 Switchboard fan
 Exhaust condenser solenoide valve
 Tank fill valve
 Main valve
 Outlet solenoide valve

DEUTSCH
 Anschlusspunkte mit R
 Anschlusspunkte 160/200 weder ohne
 Kondensator
 Hilfsrelais Spülen
 Kontaktschütz Waschpumpe
 Kontaktschütz Vorwaschpumpe
 Kontaktschütz Abzugsmotor
 Kontaktschütz Trocknungsmotor
 Kontaktschütz Vorlauf 1/2
 Kontaktschütz Rekuperatormotor
 Kontaktschütz Boilerheizung
 Kontaktschütz Trocknungsheizung
 Kontaktschütz Spülheizung
 Kontaktschütz Heizung Tank
 Kontaktschütz Heizung Tank
 Türrelais
 Dosierer Glanzmittel
 Dosierer Spülmittel
 Sicherung
 Thermorelais Abzugsmotor
 Thermoschalter Waschpumpe
 Thermorelais Trocknungsmotor
 Thermorelais Rekuperatormotor
 Thermoschalter Vorlaufmotor
 Mikroschalter Spülen
 Hauptschalter
 Mikroschalter Waschen
 Betriebstaster
 Mikroschalter Tür Spülen
 Aus-Taster
 Mikroschalter Tür Vorwaschen
 Mikroschalter Tür Tank 1/2/3
 Betriebsanzeigelampe
 Startanzeigelampe
 Füll-und Spülpumpe
 Spülpumpe
 Waschpumpe 1/2/3
 Druckpumpe
 Vorwaschpumpe
 Motor Dampfzug
 Rekuperatormotor
 Trocknungsmotor
 Vorlaufmotor
 Druckregler Spülen
 Not-Aus
 Druckregler Vorwaschen
 Druckregler Waschstufe 1 Heiz
 Druckregler Waschstufe 1 Füll
 Druckregler Waschstufe 2 Heiz
 Druckregler Waschstufe 2 Füll
 Druckwächter Spülgang 3 Füll
 Relais Generator
 Stromversorgungsanschluss Generator
 Hilfsrelais Spülen und Füllen
 Boilerheizwiderstand
 Heizwiderstand Trocknen
 Heizwiderstand Spülen
 Heizwiderstand Tank 2
 Heizwiderstand Tank 1
 Mikroschalter Zyklusende
 Thermostat zum Spülen
 Thermostat kessel
 Zeitschaltuhr Spülgang
 Start-Timer
 Trocknungs-Timer
 Rekuperator-Timer
 Transformator
 Trocknungsthermostat
 Grenzthermostat Boiler
 Thermostat Tank 1/2
 Elektroventil Füllen und Spülen
 Schalttafelventilator
 Elektroventil Dampfkondensator
 Elektroventil Tankfüllung
 Hauptelektroventil
 Ausgangelektroventil