

Зип Общепит

SCOTSMAN
vsezip.ru
+7(812)987-08-81

ELECTRONIC CUBER WITH STORAGE

ACM 125 - ACM 175

R 134 A VERSION

**SPARE PARTS LIST
CATALOGO RICAMBI
CATALOGUE PIÈCES DÉTACHÉES
ERSATZTEILENKATALOG**

Зип-Общепит

vsezip.ru

+7(812)987-08-81

PAGE PAGINA PAGE SEITE	TABLE OF CONTENTS	INDICE	TABLE DES MATIÈRES
1	TABLE OF CONTENTS	INDICE	TABLE DES MATIERES
2-3	UNIT PANELS	ASSIEME MOBILE	ENS. CARROSSERIE
4-5	REFRIGERANT SYSTEM AIR COOLED	SISTEMA REFRIGERANTE RAFFR. AD ARIA	CIRCUIT FRIGORIFIQUE REFROID. A AIR
6-7	REFRIGERANT SYSTEM WATER COOLED	SISTEMA REFRIGERANTE RAFFR. AD ACQUA	CIRCUIT FRIGORIFIQUE REFROID. A EAU
8-9	WATER SYSTEM	CIRCUITO IDRAULICO	CIRCUIT HYDRAULIQUE
10-11	P.C. BOARD AND SENSOR ASSY	SCHEDA ELETTRONICA E SENSORI	ENS. CARTE ELECTRONIQUE ET DETECTEURS
12	COMPRESSOR AND ELECTRIC COMPONENT CHARTS	TABELLA COMPRESSORI E COMPONENTI ELETRICI	LISTE DES COMPRESSEURS ET COMPOSANTS ELECTRIQUE

Зип-Общепит

vsezip.ru

+7(812)987-08-81

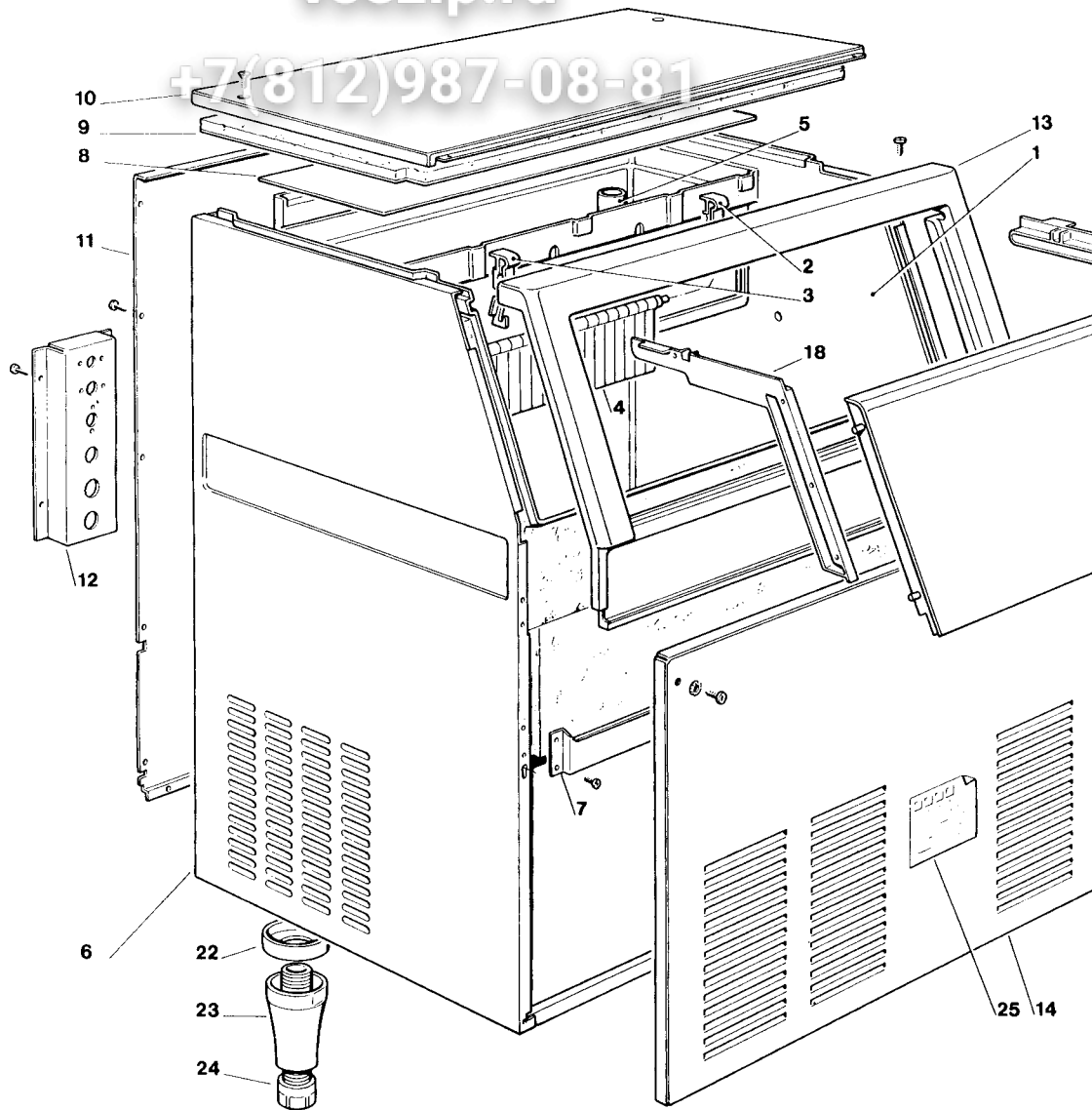

Зип-Общепит

AC 125 - AC 175 - UNIT PANELS - ASSIEME MOBILE - ENS. CARROSSERIE - MACH

vsezip.ru

+7(812)987-08-81

ITEM NO POS NO REP. NO REF. NO	PART NO CODICE REFERENCE STUECK NR	DESCRIPTION	DESCRIZIONE	DESIGNATION
1	782087 00 • 782095 00	INSULATED STORAGE BIN INSULATED STORAGE BIN	ASSIEME CELLA ISOLATA ASSIEME CELLA ISOLATA	CABINE DE STOCKAGE ISOL CABINE DE STOCKAGE ISOL
2	660388 00 •	CURTAIN BRACKET RIGHT	SUPPORTO TENDINA DX	SUPPORT RIDEAU DROITE
3	660388 01 •	CURTAIN BRACKET LEFT	SUPPORTO TENDINA SX	SUPPORT RIDEAU GAUCHE
4	784250 03R • 784457 03R	CURTAIN CURTAIN	TENDINA TENDINA	RIDEAU RIDEAU
5	281720 06	PLASTIC PIPE	TUBO IN PLASTICA	TUYAU EN PLASTIQUE
6	781404 00 721658 00 721658 01	UNIT BASE LEFT SIDE PANEL RIGHT SIDE PANEL	BASAMENTO PANNELLO LAT. SX PANNELLO LAT. DX	BASEMENT PANNEAU GAUCHE PANNEAU DROITE
7	702127 00	METAL BRACKET	SUPPORTO IN METALLO	SUPPORT METALLIQUE
8	741075 00	EVAPORATOR COVER	COPERCHIO EVAPORATORE	COUVERCLE ÉVAPORATEUR
9	794245 01	UPPER INSULATION	ISOLAMENTO SUPERIORE	ISOLATION SUPERIEUR
10	701798 01	TOP PANEL S.S.	PANNELLO SUPERIORE ACC. INOX	PANNEAU SUPERIEURE ACCI
11	702218 00	REAR PANEL	PANNELLO POSTERIORE	PANNEAU ARRIERE
12	722180 00	METAL BRACKET FOR FITTINGS S.S.	SUPPORTO ATTACCHI ACC. INOX	SUPPORT DE RACC. ACIER I
13	782078 10 721669 00	BIN DOOR FRAME ASSY S.S. FRONT PLATE	ASSIEME CORNICE SPORTELLO FRONTALINO ACC. INOX	ENS. ENCADREMENT PORTE BANDE ENTRETOISE ACIER
14	721659 00	FRONT PANEL S.S.	PANNELLO FRONTALE ACCIAIO INOX	PANNEAU AVANT ACIER INO
17	660523 00	RIGHT BIN DOOR GUIDE	GUIDA SPORTELLO DESTRA	GLISSIER DE PORTE DROITE
18	660523 01	LEFT BIN DOOR GUIDE	GUIDA SPORTELLO SINISTRA	GLISSIER DE PORTE GAUCH
19	792009 09	BIN DOOR ASSY	ASSIEME SPORTELLO	ENSAMBLE PORTE CABINE
20	660286 00	DOOR RUNNER - BUSHING	BUSSOLE DI SCORRIMENTO	BAGUE DE COULISSAGE PO
22-23-24	650670 00	KIT LEG + LEG LEVELLER (4 PCS)	KIT PIEDINO + VITE DI REGOLAZIONE (4 PZ.)	KIT PIED + VIS DE REGLAGE DES PI
25	650624 08	LABEL	ADESIVO SEGNALETICO	ETIQUETTE
*	660614 00	SCOTSMAN LOGO	EMBLEMA SCOTSMAN	EMBLÈME SCOTSMAN
		* NOT SHOWN • UP TO AC 125 S.N. 29174 AND AC 175 S.N. 3885	* NON MOSTRATO • FINO AD AC 125 S.N. 29174 ED AC 175 S.N. 3885	* PAS MONTRÉ • JUSQU'À AC 125 S.N. 29174 AC 175 N.S. 3885

Зип-Общепит

vsezip.ru

+7(812)987-08-81

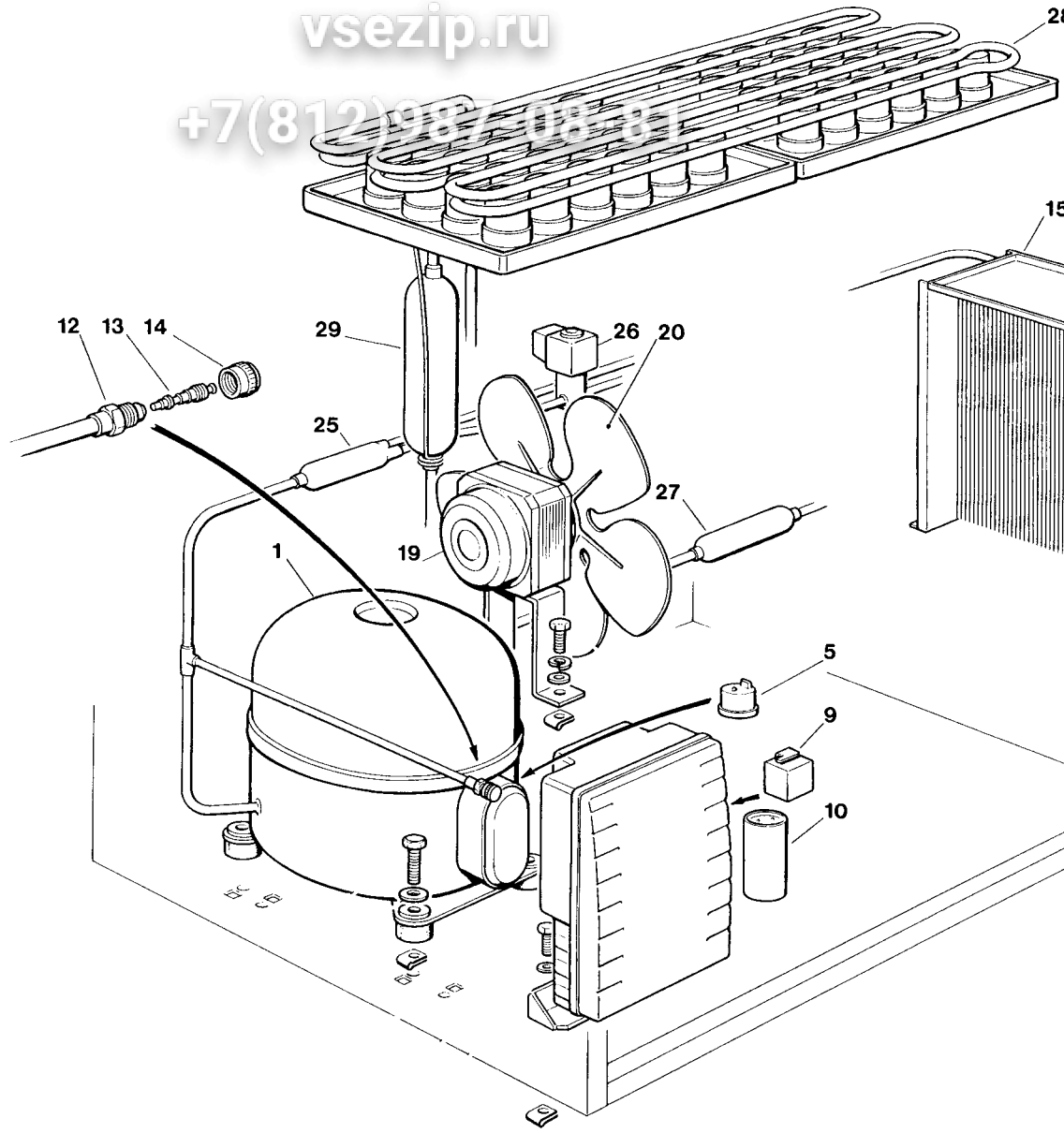

AC 125 - AC 175 - REFRIGERANT SYSTEM AIR COOLED - SISTEMA REFRIGERANTE

CIRCUIT FRIGORIFIQUE REFRROID. PAR AIR - LUFTGEKÜHLT GEFRIERSYST

ITEM NO POS NO REP. NO REF. NO	PART NO CODICE REFERENCE STUECK NR	DESCRIPTION	DESCRIZIONE	DESIGNATION
1	670099 02 670099 03	COMPRESSOR ASSY - AC 125 COMPRESSOR ASSY - AC 175	ASSIEME COMPRESSORE - AC 125 ASSIEME COMPRESSORE - AC 175	ENSAMBLE COMPRESSEUR ENSAMBLE COMPRESSEUR
5	620058 39 620058 42	PROTECTOR - AC 125 PROTECTOR - AC 175	PROTETTORE - AC 125 PROTETTORE - AC 175	PROTECTEUR - AC 125 PROTECTEUR - AC 175
9	620057 44 620057 45	START RELAY - AC 125 START RELAY - AC 175	RELE DI AVVIAMENTO - AC 125 RELE DI AVVIAMENTO - AC 175	RELAIS DE DEMARRAGE - AC 125 RELAIS DE DEMARRAGE - AC 175
10	620167 01 620167 01	START CAPACITOR - AC 125 START CAPACITOR - AC 175	CAPACITA D'AVVIAMENTO - AC 125 CAPACITA D'AVVIAMENTO - AC 175	CAPACITE DE DEMARRAGE CAPACITE DE DEMARRAGE
12	650109 00	VALVE BODY	CORPO VALVOLA	CORPS DE VANNE
13	670012 00	VALVE PISTON	PISTONCINO VALVOLA	PISTON
14	650106 00	VALVE CAP	CAPPUCCIO VALVOLA	CAPUCHON DE VANNE
15	620405 00 620440 00	AIR COOLED CONDENSER - AC 125 AIR COOLED CONDENSER - AC 175	CONDENSATORE AD ARIA - AC 125 CONDENSATORE AD ARIA - AC 175	CONDENSEUR A AIR - AC 125 CONDENSEUR A AIR - AC 175
19	620419 02 620419 04	FAN MOTOR - AC 125 FAN MOTOR - AC 175	MOTORE VENTILATORE - AC 125 MOTORE VENTILATORE - AC 175	MOTEUR VENTILATEUR - AC 125 MOTEUR VENTILATEUR - AC 175
20	620419 33	FAN BLADE	VENTOLA	HELICE
25	630020 01	MECHANICAL FILTER	FILTRO MECCANICO	FILTRE MECANIQUE
26	620306 27 620306 48	HOT GAS VALVE ASSY HOT GAS VALVE COIL	CORPO VALVOLA GAS CALDO BOBINA VALVOLA GAS CALDO	CORP VANNE GAZ CHAUD BOBINE VANNE GAZ CHAUD
27	630003 06	DRIER	FILTRO DEUMIDIFICATORE	FILTRE DESHYDRATEUR
28	784263 00 784283 00	EVAPORATOR ASSY-ACM EVAPORATOR ASSY-ACS	ASSIEME EVAPORATORE-ACM ASSIEME EVAPORATORE-ACS	ENSAMBLE ÉVAPORATEUR-ACM ENSAMBLE ÉVAPORATEUR-ACS
29	784444 06 784444 11	SUCTION LINE/ACCUMULATOR AC 125 SUCTION LINE/ACCUMULATOR AC 175	ACCUMUL. E LINEA ASPIRAZIONE AC 125 ACCUMUL. E LINEA ASPIRAZIONE AC 175	ENS. ASPIRATION/ACCUMULATEUR AC 125 ENS. ASPIRATION/ACCUMULATEUR AC 175
*	650694 00	SUCTION SERVICE VALVE	RUBINETTO DI CARICA	ROBINET DE SERVICE
		* NOT SHOWN	* NON MOSTRATO	* PAS MONTRÉ

Зип-Общепит

vsezip.ru

+7(812)987-08-81

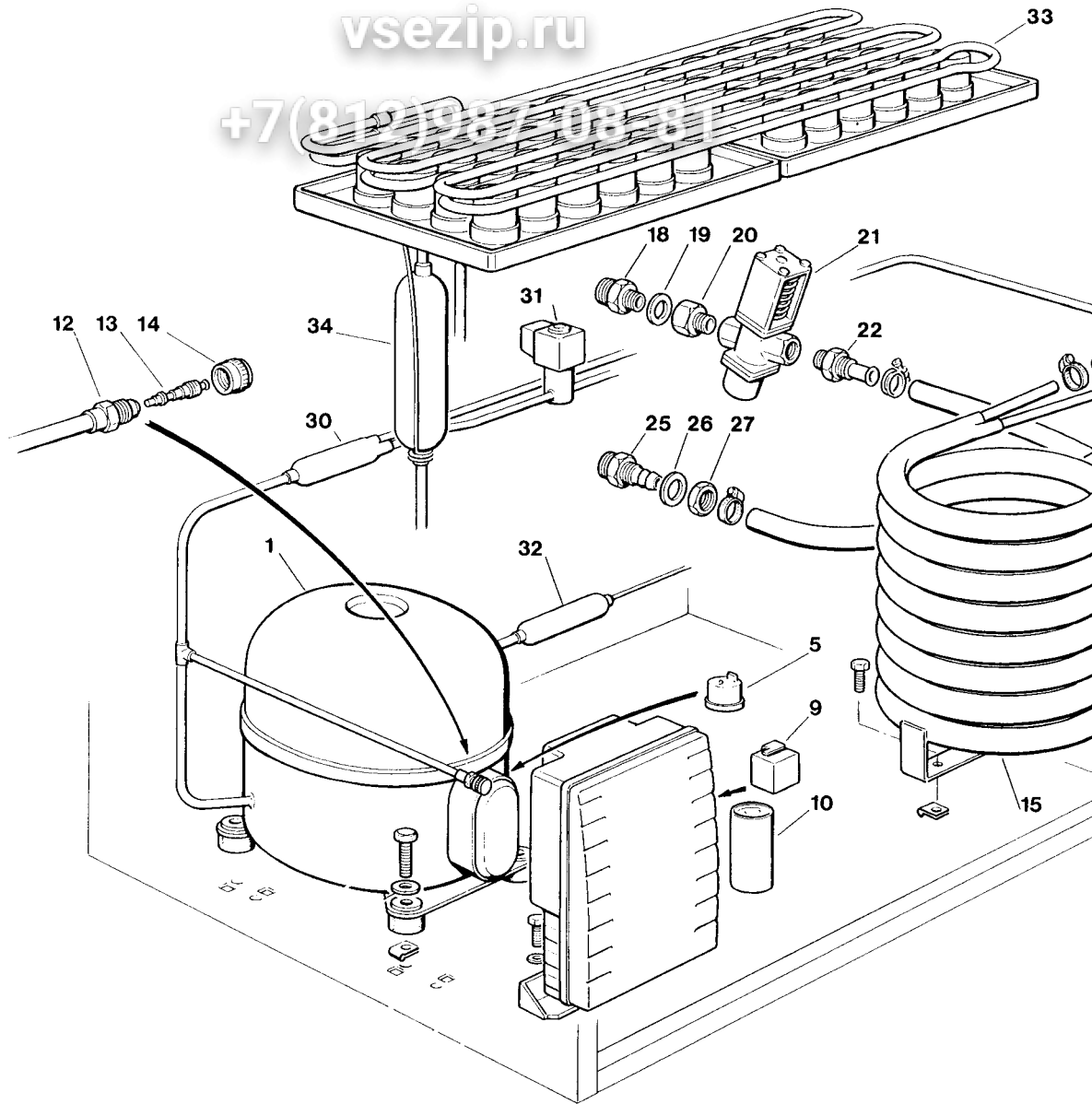

Зип-Общепит
vsezip.ru
+7(812)987-08-81

AC125 - AC 175 - REFRIGERANT SYSTEM WATER COOLED - SISTEMA REFRIGERANTE CIRCUIT FRIGORIFIQUE REFROID. PAR EAU - WASSERGEKÜHLT GEFRIERSYSTEM

ITEM NO POS NO REP. NO REF. NO	PART NO CODICE REFERENCE STUECK NR		DESCRIPTION	DESCRIZIONE	DESIGNATION
	ACM 125	ACM 175			
1	670099 02 670099 03		COMPRESSOR ASSY - AC 125 COMPRESSOR ASSY - AC 175	ASSIEME COMPRESSORE - AC 125 ASSIEME COMPRESSORE - AC 175	ENSAMBLE COMPRESSEUR ENSAMBLE COMPRESSEUR
5	620058 39 620058 42		PROTECTOR - AC 125 PROTECTOR - AC 175	PROTETTORE - AC 125 PROTETTORE - AC 175	PROTECTEUR - AC 125 PROTECTEUR - AC 175
9	620057 44 620057 45		START RELAY - AC 125 START RELAY - AC 175	RELE DI AVVIAMENTO - AC 125 RELE DI AVVIAMENTO - AC 175	RELAIS DE DEMARRAGE - AC 125 RELAIS DE DEMARRAGE - AC 175
10	620167 01 620167 01		START CAPACITOR - AC 125 START CAPACITOR - AC 175	CAPACITA D'AVVIAMENTO - AC 125 CAPACITA D'AVVIAMENTO - AC 175	CAPACITE DE DEMARRAGE - AC 125 CAPACITE DE DEMARRAGE - AC 175
12	650109 00		VALVE BODY	CORPO VALVOLA	CORPS DE VANNE
13	670012 00		VALVE PISTON	PISTONCINO VALVOLA	PISTON
14	650106 00		VALVE CAP	CAPPUCCIO VALVOLA	CAPUCHON DE VANNE
15	620389 01	620331 00	WATER COOLED CONDENSER	CONDENSATORE AD ACQUA	CONDENSEUR A EAU
18	400053 00		NUT	DADO	ECROU
19	400052 00		FIBER WASHER	RONDELLA IN FIBRA	RONDELLE EN FIBRE
20	733204 00		WATER INLET FITTING	RACCORDO INGRESSO ACQUA	RACCORD ARRIVÉE D'EAU
21	620111 00		WATER REGULATING VALVE	VALVOLA PRESSOSTATICA	VANNE A EAU PRESSOSTATICA
22	733094 03		REGULATING VALVE OUTLET FITTING	RACCORDO USCITA VALVOLA PRESS.	RACCORD SORTIE VANNE PRESS.
24	281900 01		PLASTIC TUBE-PER METER	TUBO IN PLASTICA-PER METRO	TUYAU EN PLASTIQUE-PER METRE
25	660291 00		WATER DRAIN FITTING	RACCORDO SCARICO ACQUA	RACCORD ÉVACUATION EAU
26	400031 00		FIBER WASHER	RONDELLA IN FIBRA	RONDELLE EN FIBRE
27	400030 01		NUT	DADO	ECROU
29	281900 01		PLASTIC TUBE-PER METER	TUBO IN PLASTICA-PER METRO	TUYAU EN PLASTIQUE-PER METRE
30	630020 01		MECHANICAL FILTER	FILTRO MECCANICO	FILTRE MECHANIQUE
31	620306 27 620306 48		HOT GAS VALVE BODY HOT GAS VALVE COIL	CORPO VALVOLA GAS CALDO BOBINA VALVOLA GAS CALDO	CORP VANNE GAZ CHAUD BOBINE VANNE GAZ CHAUD
32	630003 06		DRIER	FILTRO DEUMIDIFICATORE	FILTRE DESHYDRATEUR
33	784263 00 784283 00		EVAPORATOR ASSY-ACM EVAPORATOR ASSY-ACS	ASSIEME EVAPORATORE-ACM ASSIEME EVAPORATORE-ACS	ENSAMBLE ÉVAPORATEUR-ACM ENSAMBLE ÉVAPORATEUR-ACS
34	784444 06 784444 11		SUCTION LINE/ACCUMULATOR AC 125 SUCTION LINE/ACCUMULATOR AC 175	ACCUMUL. E LINEA ASPIRAZIONE AC 125 ACCUMUL. E LINEA ASPIRAZIONE AC 175	ENS. ASPIRATION/ACCUMULATEUR AC 125 ENS. ASPIRATION/ACCUMULATEUR AC 175
*	650694 00		SUCTION SERVICE VALVE	RUBINETTO DI CARICA	ROBINET DE SERVICE
			* NOT SHOWN	* NON MOSTRATO	* PAS MONTRÉ

Зип-Общепит

vsezip.ru

+7(812)987-08-81

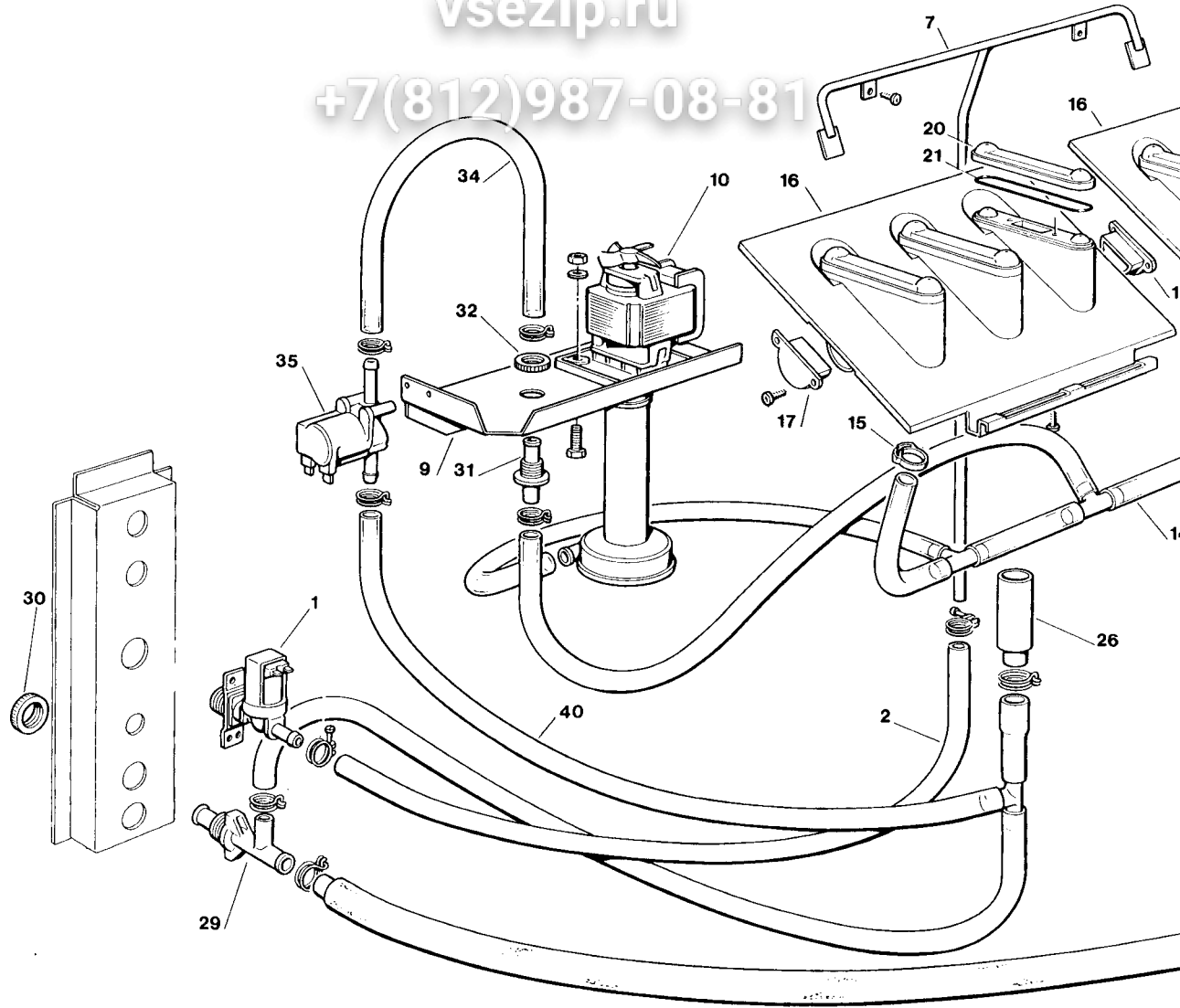

AC 125 - AC 175 - WATER SYSTEM - CIRCUITO IDRAULICO - CIRCUIT HYDRAULIQUE

vsezip.ru

ITEM NO POS NO REP. NO REF. NO	PART NO CODICE REFERENCE STUECK NR	DESCRIPTION	DESCRIZIONE	DESIGNATION
1	650105 52	WATER INLET VALVE	VALVOLA INGRESSO ACQUA	VANNE ARRIVÉE D'EAU
2	291900 01	WATER INLET TUBE-PER METER	TUBO INGRESSO ACQUA-PER METRO	TUYAU ARRIVÉE D'EAU-POU
7	660537 00	WATER DISTRIBUTOR TUBE	TUBO DISTRIBUTORE D'ACQUA	TUYAU DISTRIBUTEUR EAU
9	723156 00 • 724344 00	PUMP MOTOR BRACKET PUMP MOTOR BRACKET	SUPPORTO POMPA SUPPORTO POMPA	SUPPORT METALLIQUE POM SUPPORT METALLIQUE POM
10	793146 03	WATER PUMP ASSY	ASSIEME POMPA	ENSAMBLE POMPE A EAU
14	610186 00	WATER TUBE - PUMP TO SPRAY SYSTEM	TUBO MANDATA POMPA	TUYAU - POMPE PLAQUE D'AR
15	650499 01	PLASTIC CLAMP	FASCETTA IN PLASTICA	COLLIER EN PLASTIQUE
16	793129 01	SPRAY PLATEN ASSY	ASSIEME PIASTRA SPRUZZANTE	ENS. PLAQUE PULVERISATIO
17	660520 03	PLASTIC PLUG	TAPPO IN PLASTICA	BOUCHON EN PLASTIQUE
18	660520 02	PLASTIC PLUG	TAPPO IN PLASTICA	BOUCHON EN PLASTIQUE
20	660519 01	PLASTIC COVER	COPERCHIO IN PLASTICA	COUVERCLE EN PLASTIQUE
21	640041 20	O RING	GUARNIZIONE OR	JOINT TORIQUE
26	281720 06	OVERFLOW STAND PIPE	TUBO TROPPO PIENEO	TUYAU TROP PLEIN
27	610148 15	WATER DRAIN TUBE	TUBO SCARICO ACQUA	TUYAU ÉVACUATION EAU
29	660224 00	DRAIN T FITTING	RACCORDO DI SCARICO	RACCORD T D'EVACUATION
30	660535 00	PLASTIC RING NUT	GHIERA IN PLASTICA	COLLIER DE SERRAGE EN P
31	660534 00	PLASTIC FITTING	RACCORDO DI SCARICO	RACCORD EVACUATION
32	660535 00	PLASTIC RING NUT	GHIERA IN PLASTICA	COLLIER DE SERRAGE EN P
34	610173 00	TUBE	TUBO	TUYAU
35	620406 01	WATER DRAIN VALVE	VALVOLA SCARICO ACQUA	VANNE VIDANGE EAU
36	660219 01	DRAIN FITTING	RACCORDO DI SCARICO	RACCORD EVACUATION
37	640134 00	O RING	GUARNIZIONE O R	JOINT TORIQUE
38	660211 01	DRAIN FILTER	FILTRO SCARICO ACQUA	FILTRE EVACUATION EAU
40	610176 01	TUBE	TUBO	TUYAU
		• UP TO AC 125 S.N. 29174 AND AC 175 S.N. 3885	• FINO AD AC 125 S.N. 29174 ED AC 175 S.N. 3885	• JUSQU'À AC 125 S.N. 29174 AC 175 N.S. 3885

Зип-Общепит

vsezip.ru

+7(812)987-08-81

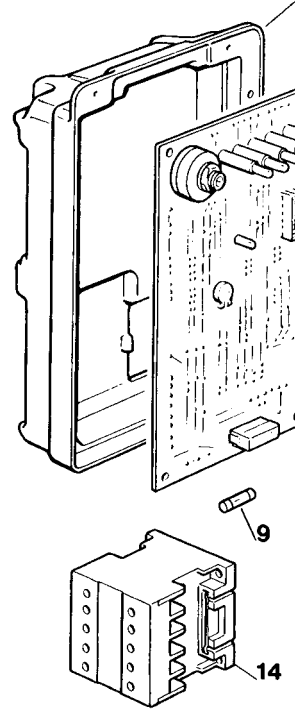
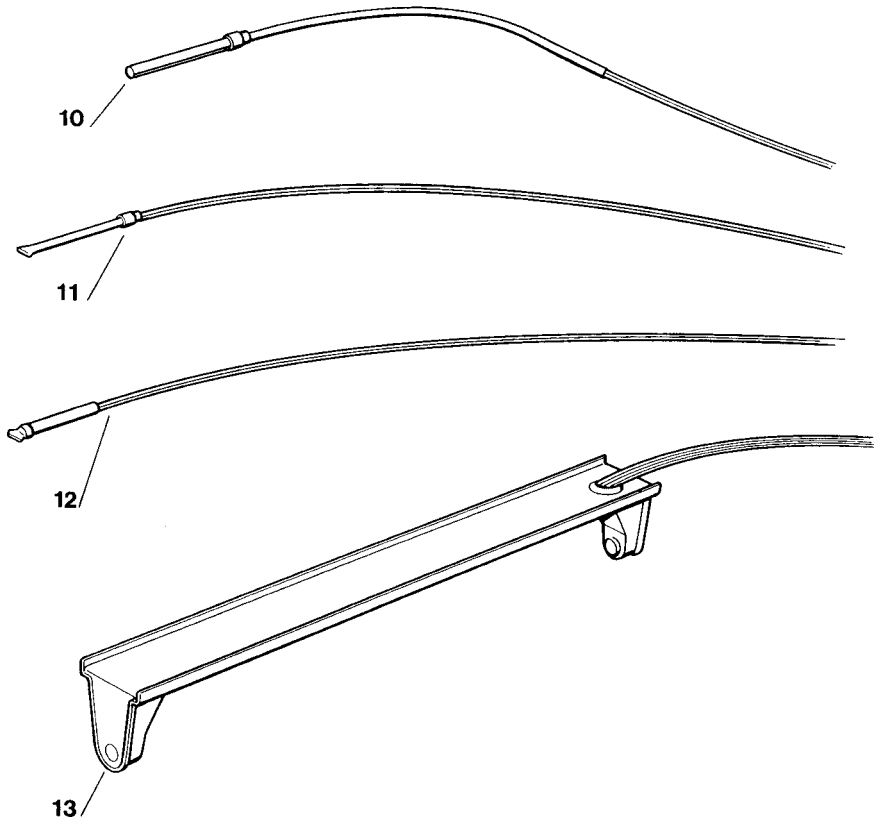

Зип-Общепит

AC125 - AC 175 - P.C. BOARD AND SENSOR ASSY - SCHEDA ELETTRONICA M
 ENS. CARTE ELECTRONIQUE ET DETECTEURS - ELEKTRONISCHE KARTE UND TEMPERATU

vsezip.ru

+7(812)987-08-81

ITEM NO POS NO REP. NO REF. NO	PART NO CODICE REFERENCE STUECK NR	DESCRIPTION	DESCRIZIONE	DESIGNATION
4	660546 00	CONTROL BOX	SCATOLA ELETTRICA	BOITE ELECTRIQUE
6	660547 00	CONTROL BOX COVER	COPERCHIO SCATOLA ELETTRICA	COUVERCLE BOITE DE COM
8	620403 18 620403 19	P. C. BOARD ASSY RECYCLED PCB	ASSIEME SCHEDA ELETTRONICA SCHEDA EL. RICICLATA	ENSAMBLE CARTE ELECTRO CARTE ELECTR. RECYCLE
9	630015 09 630015 10	FUSE (100 mA) FUSE (16 A)	FUSIBILE (100mA) FUSIBILE (16 A)	FUSIBLE (100mA) FUSIBLE (16 A)
10	620404 10	EVAPORATOR TEMP. SENSOR	SENSORE TEMP. EVAPORATORE	CAPTEUR TEMP. ÉVAPORAT
11	620404 01	CONDENSER TEMP. SENSOR	SENSORE TEMP. CONDENSATORE	CAPTEUR TEMP. CONDENSE
12	620404 02	AMBIENT TEMP. SENSOR	SENSORE TEMP. AMBIENTE	CAPTEUR TEMP. AMBIANCE
13	650674 00	ICE LEVEL CONTROL ASSY	ASS. CONTR. LIVELLO GHIACCIO	ENS. DETECTEUR NIVEAU G
14	630119 02	CONTACTOR	TELERUTTORE	CONTACTEUR

AC 125 - AC 175 - COMPRESSOR CHART - TABELLA COMPRESSORI - TABLEAU COMPRESSEUR					
MODEL MODELLO MODELE MODELL	VOLTS TENSIONE TENSION SPANNUNG	COMPRESSOR MODEL MOD. COMPRESSORE TYPE COMPRESSEUR KOMPRESSOR TYP	COMPRESSOR COMPRESSORE COMPRESSEUR KOMPRESSOR	RELAY RELE RELAIS RELAIS	PRO PRO SCHU
ACM 125	115/60/1	U.H. CAJ 4461 Y U.H. CAJ 4492 Y	670099 11 670099 12	620057 52 620057 53	620 620
ACM 125 ACM 175	230/60/1 230/60/1	U.H. CAJ 4461 Y U.H. CAJ 4492 Y	670099 07 670099 08	620057 48 620057 45	620 620
ACM 125 ACM 175	230/50/1 230/50/1	U.H. CAJ 4461 Y U.H. CAJ 4492 Y	670099 02 670099 03	620057 44 620057 45	620 620

AC 125 - AC 175 - ELECTRIC COMPONENTS CHART - TABELLA COMPONENTI TABLEAU COMPOSANTS ELECTRIQUE - ELEKTRISCHEKARTE							
MODEL MODELLO MODELE MODELL	VOLTS TENSIONE TENSION SPANNUNG	CONTACTOR TELERUTTORE CONTACTEUR SCHALTSCHÜTZ	WATER PUMP POMPA POMPE A EAU WASSER PUMPE	FAN MOTOR ONLY MOTORE VENTILATORE MOTEUR VENTILATEUR LUFTER MOTOR	WATER INLET VALVE VALV. INGR. ACQUA V.E.M. ARRIVEE EAU WASSEREIN.VENTIL	HOT GAS VALVE VALVOLA GAS CALDO V.E.M. GAZ CHAUDS HEISSGAZ VENTIL	S C E
ACM 125	115/60/1	630124 07	620430 04	620419 03	-	620306 17	
ACM 125 ACM 175	230/60/1 230/60/1	630119 02 630119 02	620430 05 620430 05	620419 02 620419 04	650105 52 650105 52	620306 48 620306 48	
ACM 125 ACM 175	230/50/1 230/50/1	630119 02 630119 02	620430 03 620430 03	620419 02 620419 04	650105 52 650105 52	620306 48 620306 48	