

Зип Общепит

vsezip.ru

AF430 Parts List

+7(812)987-08-81

Table of Contents

Cabinet

Air Cooled Parts

Water Cooled Parts

Compressor

Spout

Freezer

Gearmotor

Control Box

Wiring Diagrams

vsezip.ru

+7(812)987-08-81

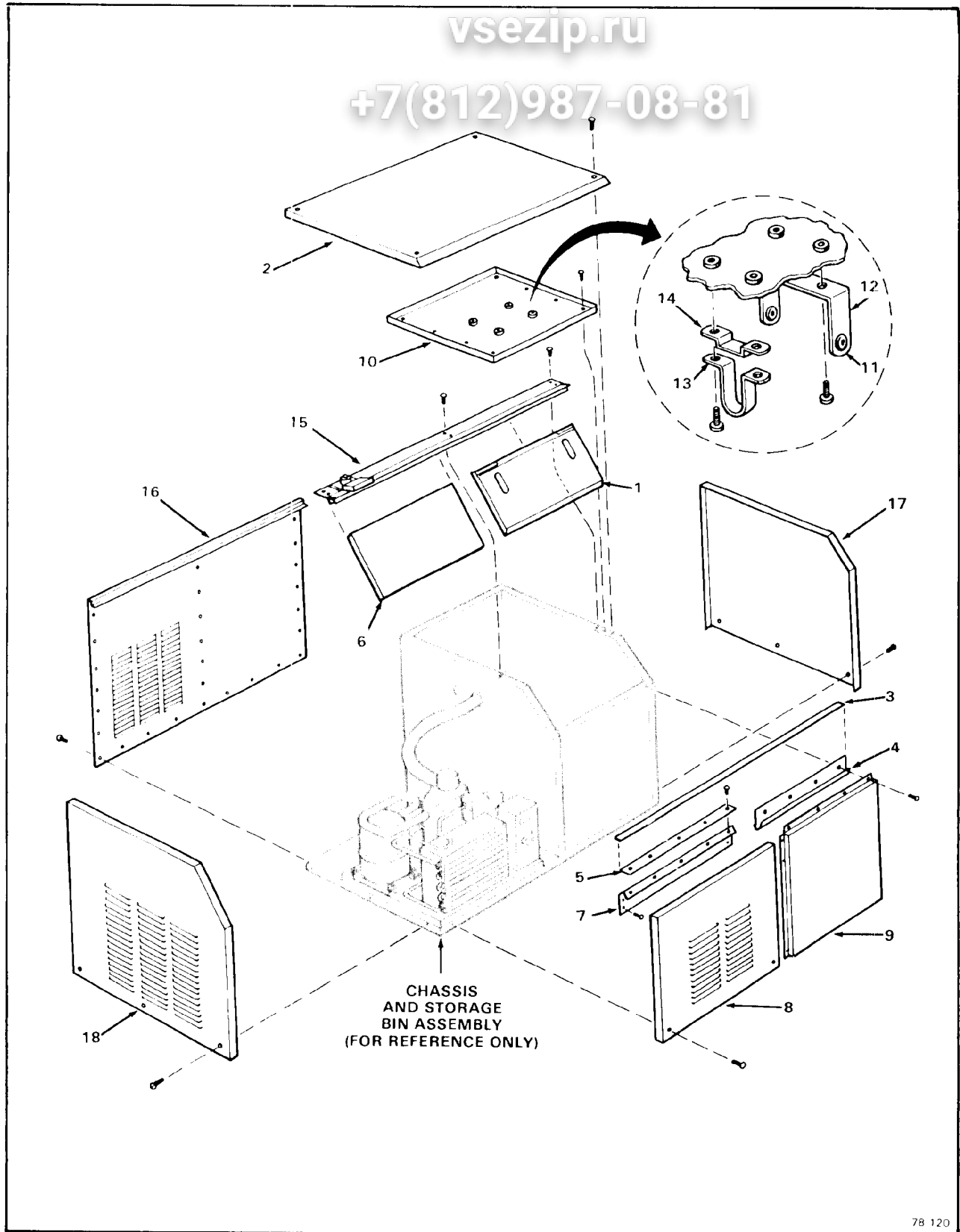

Figure 8-1. AF-430 Cabinet.

Figure 8-1. AF-430 Cabinet

vsezip.ru

+7(812)987-08-81

INDEX NO.	DESCRIPTION	PART NUMBER	REQ'D NUMBER
	AF-430 Cabinet * * *	No Number	1
1	Door, Ice Access (Orange w/C.R.S. Painted Cabinet) Door, Ice Access (Gray w/Stainless Steel Cabinet) * * *	02-2130-01 02-2130-02	1 1
2	Panel, Top (C.R.S.) Painted) Panel, Top (Stainless Steel) attaching parts, Index 2 Screw, No. 8 x 1-3/4 S/T Flat Hd * * *	A24799-004 A24799-005 03-1419-19	1 1 4
3	Insert, Plastic (43.44 in. lg.) * * *	15-0324-00	1
4	Strip, Moulding — Right Side attaching parts, Index 4 & 9 Screw, No. 8 x 3/8 S/T Flat Hd * * *	15-0620-01 03-1419-05	1 4
5	Strip, Moulding — Left Side attaching parts, Index 5 to 8 Screw, No. 8 x 3/8 S/T Flat Hd * * *	15-0578-01 03-1419-05	1 5
6	Panel, Upper — Left Front (C.R.S. Painted) Panel, Upper — Left Front (Stainless Steel) * * *	A24795-003 A24795-002	1 1
7	Bracket, Left Front attaching parts, Index 5 & 7 Screw, No. 8 x 1/2 T/F Tap * * *	A24787-001 03-1404-09	1 4
8	Panel, Lower — Left Front (C.R.S. Painted) Panel, Lower — Left Front (Stainless Steel)	A24796-003 A24796-004	1 1

Figure 8-1. AF-430 Cabinet. (cont'd)

INDEX NO.	DESCRIPTION	PART NUMBER	REQ'D NUMBER
	attaching parts, Index 8		
	Screw, No. 8 x 1-1/2 S/T Flat Hd * * *	03-1419-16	2
9	Panel, Right Front (C.R.S. Painted)	A24794-003	1
	Panel, Right Front (Stainless Steel)	A24794-002	1
	attaching parts, Index 4 & 9		
	Screw, No. 8 x 3/8 S/T Flat Hd * * *	03-1419-05	Ref.
10	Cover, Storage Bin	A27980-001	1
	attaching parts, Index 10		
	Screw, No. 8 x 1/2 T/F Tap * * *	03-1404-09	10
11	Grommet	13-0557-00	2
12	Bracket, Bin Thermo	A27924-001	1
13	Holder, Tube	A27922-001	1
14	Retainer, Tube	A27923-001	1
	attaching parts, Index 12, 13, 14 to 10		
	Screw, Thumb -- No. 10-24 x 1/2 Knurled Hd * * *	03-0727-00	4
15	Track Assembly, Door	A28823-001	1
	attaching parts, Index 15		
	Screw, No. 8 x 1/2 T/F Tap * * *	03-1404-09	6
16	Panel, Back (Galvanized Steel)	A27033-003	1
	attaching parts, Index 16		
	Lockwasher, No. 8 External Tooth -- Carbon Steel Zinc Plated	03-1417-03	4
	Screw, No. 8 x 1/2 T/F Tap * * *	03-1404-09	27
17	Panel, Right Side (C.R.S. Painted)	A24800-003	1
	Panel, Right Side (Stainless Steel)	A24800-002	1

Зип Общепит

Figure 8-1. AF-430 Cabinet. (cont'd)

INDEX NO.	DESCRIPTION	PART NUMBER	REQ'D NUMBER
18	attaching parts, Index 17		
	Screw, No. 8 x 1/2 T/F Tap (SS)	03-1404-10	5

	Panel, Left Side (C.R.S. Painted)	A27034-003	1
	Panel, Left Side (Stainless Steel)	A27034-002	1
	attaching parts, Index 18		
	Lockwasher, No. 8 External Tooth -- Carbon Steel Zinc Plated	03-1417-03	2
	Screw, No. 8 x 1/2 T/F Tap (SS)	03-1404-10	3

vsezip.ru

+7(812)987-08-81

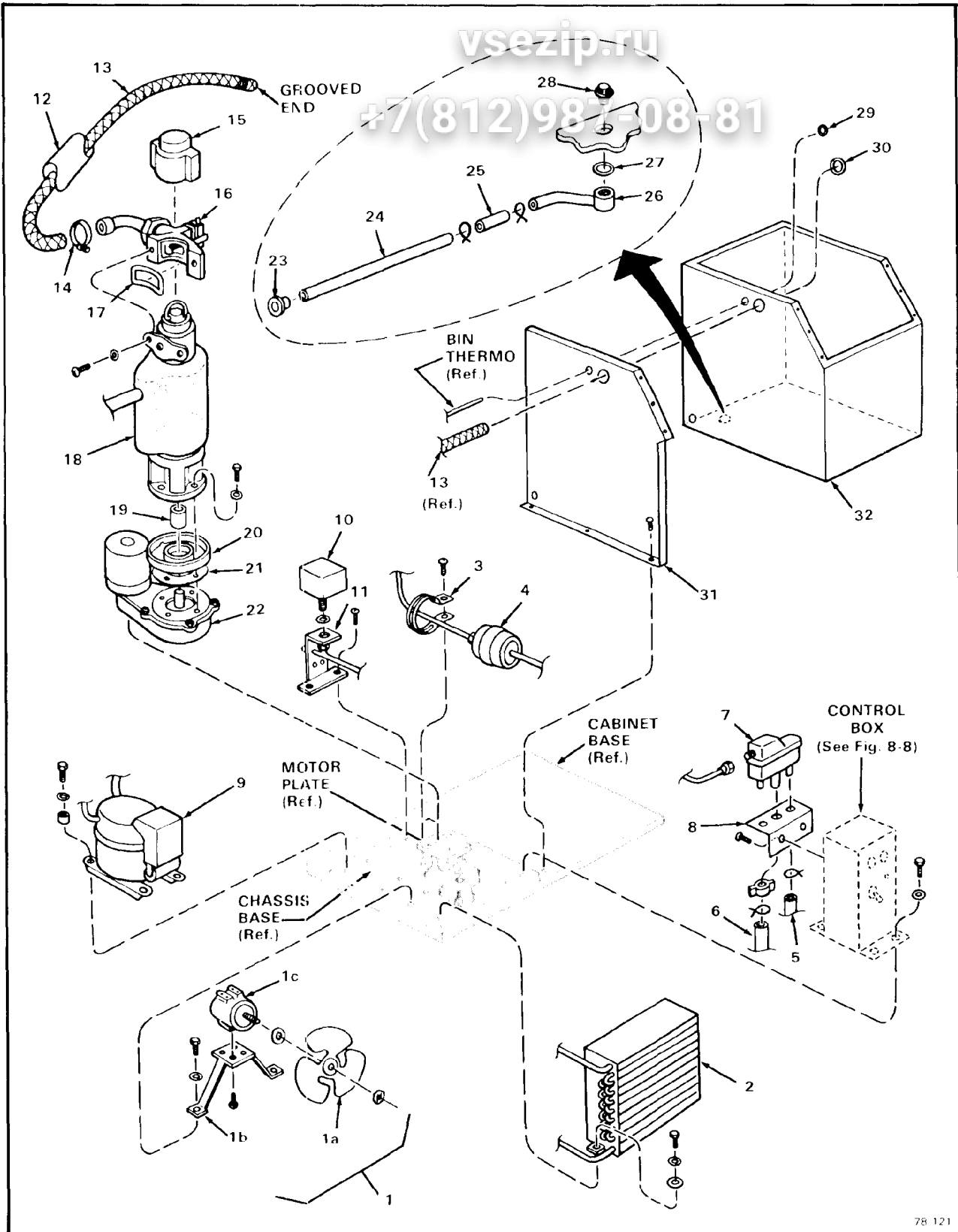

Figure 8-2. Major Assemblies - Air-Cooled Models.

Зип Общепит

Figure 8-2. Major Assemblies — Air-Cooled Models

vsezip.ru

+7(812)987-08-81

INDEX NO.	DESCRIPTION	PART NUMBER	REQ'D NUMBER
	Major Assemblies - Air-Cooled Models * * *	No. Number	Ref.
1	Bracket Assembly, Fan Motor and Mounting	No Number	1
1a	Blade, Fan	18-3309-01	1
	Pad, Vibration (p/o Fan Motor)	No Number	1
	Nut, Fan Mounting (p/o Fan Blade)	No Number	1
1b	Bracket, Fan Mounting	18-0422-00	1
1c	Motor, Fan	12-1576-01	1
	attaching parts, Index 1c to 1b		
	Screw (p/o Fan Motor)	No Number	4
	attaching parts, Index 1 to Chassis base		
	Lockwasher, No. 1/4 External Tooth - Carbon Steel Zinc Plated	03-1417-09	2
	Screw, No. 1/4-20 x 1/2 T/C Hex Hd	03-0571-00	2
	* * *		
2	Condenser - Air-Cooled	18-3717-01	1
	attaching parts, Index 2		
	Lockwasher, No. 1/4 External Tooth - Carbon Steel Zinc Plated	03-1417-09	2
	Screw, No. 1/4-20 x 1/2 T/C Hex Hd	03-0571-00	2
	* * *		
3	Brace, Drier	A09386-000	1
4	Drier	02-2426-01	1
	attaching parts, Index 3 and 4		
	Screw, No. 10-16 x 3/4 S/T	03-1360-01	1
	* * *		
5	Tube (Reservoir Overflow to Drip Pan)	13-0079-03	1
6	Tube (Reservoir to Freezer Inlet)	13-0674-09	1
	attaching parts, Index 5 and 6		
	Clamp (Index 5)	02-0535-00	1
	Clamp (Index 6)	02-0694-00	2
	* * *		

Figure 8-2. Major Assemblies — Air-Cooled Models (Cont'd)

INDEX NO.	DESCRIPTION	PART NUMBER	REQ'D NUMBER
7	Reservoir	02-2217-01	1
	Valve Assembly, Float (Not Shown)	02-2217-02	1
	attaching parts, Index 7		
	Wing Nut (p/o Reservoir)	No Number	1
	* * *		
8	Bracket, Mounting	A20959-000	1
	attaching parts, Index 8		
	Screw, No. 8-18 x 1/2 Phil Pan Hd	03-1572-01	2
	* * *		
9	Compressor (See Figure 8-4)	18-4500-01	1
	attaching parts, Index 9		
	Grommet	18-2200-28	4
	Sleeve, Mounting	18-2200-27	4
	Lockwasher, No. 5/16 External Tooth - Carbon Steel Zinc Plated	03-1417-12	4
	Washer, Special	03-1408-24	4
	Screw, No. 5/16-18 x 1-3/4 Hex Cap	03-1405-40	4
	* * *		
10	Control, Pressure - H ² O	11-0296-00	1
11	Bracket, Utility	A27993 001	1
	O-Ring	13 0617 26	1
	attaching parts, Index 10 and 11		
	Nut, Pal	03-1394-00	1
	Screw, No. 10-16 x 3/4 S/T	03-1360-01	2
	* * *		
12	Covering, Tube	13-0279-00	1
13	Tube, Ice	A28042-006	1
	attaching parts, Index 12 and 13		
14	Clamp, Hose	02-0179-02	1
	* * *		

Figure 8-2. Major Assemblies — Air-Cooled Models (Cont'd)

INDEX NO.	DESCRIPTION	PART NUMBER	REQ'D NUMBER
15	Cap, Freezer * * *	13-0815-01	1
16	Spout Assembly (See Figure 8-5)	No Number	1
17	Gasket, Spout attaching parts, Index 16 and 17 Washer, No. 1/4 Internal Tooth - Phosphor Bronze Screw, No. 1/4-20 x 1 Soc-Hd Cap (SS) * * *	13-0679-00 03-1417-07 03-1544-03	1 2 2
18	Freezer Assembly (See Figure 8-6) attaching parts, Index 18 Lockwasher, No. 5/16 External Tooth - Carbon Steel Zinc Plated Screw, No. 5/16-18 x 3/4 Hex Cap * * *	No Number 03-1417-12 03-1420-04	1 3 3
19	Coupling * * *	15-0575-01	1
20	Pan, Drip * * *	A18153-000	1
21	Gasket * * *	13-0628-00	1
22	Drivemotor Assembly (See Figure 8-7) attaching parts, Index 22 Lockwasher, No. 1/4 External Tooth - Carbon Steel Zinc Plated Screw, No. 1/4-20 x 1/2 Hex Cap * * *	A31977-021 03-1417-09 03-1405-03	1 4 4
23	Bushing, Snap * * *	12-1213-10	1
24	Tube, Bin Drain	No Number	1

Figure 8-2. Major Assemblies — Air-Cooled Models (Cont'd)

INDEX NO.	DESCRIPTION	PART NUMBER	REQ'D NUMBER
25	Tube, Tygon attaching parts, Index 24, 25, 26	13-0674-06	1
	Clamp, Hose * * *	02-1338-00	2
26	Drain Bin	A27018-001	1
27	O-Ring attaching parts, Index 26, 27, 28 to 32	13-0617-11	1
28	Top, Drain (screws into Index 26) * * *	02-1741-00	1
29	Grommet * * *	13-0557-01	1
30	Pad, Sealing * * *	13-0806-01	1
31	Retainer, Insulation attaching parts, Index 31	No Number	1
	Screw, No. 8 x 1/2 T/F Tap * * *	03-1404-09	3
32	Bin, Storage * * *	02-2762-02	1
NOTE: See Figure 8-8 for replacement parts within the Control Box Assembly.			

vsezip.ru

+7(812)987-08-81

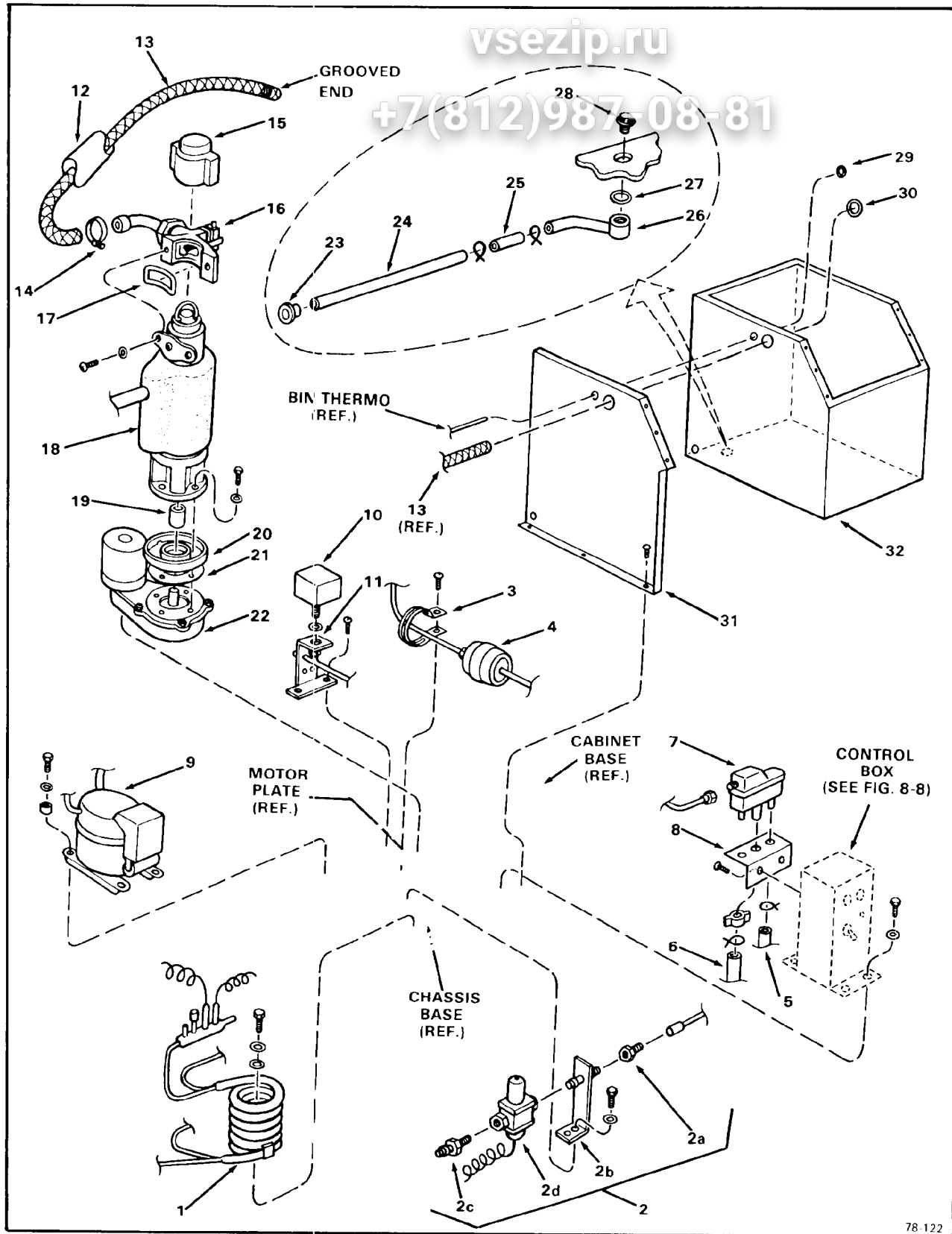

78.122

Figure 8-3. Major Assemblies - Water-Cooled

Figure 8-3. Major Assemblies — Water-Cooled Models

INDEX NO.	DESCRIPTION	PART NUMBER	REQ'D NUMBER
	Major Assemblies - Water-Cooled Model * * *	No Number	Ref.
1	Condenser - Water-Cooled attaching parts, Index 1 Lockwasher, No. 1/4 External Tooth - Carbon Steel Zinc Plated Screw, No. 1/4-20 x 1/2 T/C Hex Hd * * *	18-3303-02 03-1417-09 03-0571-00	1 2 2
2	Regulator Assembly, Water attaching parts, Index 2 Lockwasher, No. 1/4 External Tooth - Carbon Steel Zinc Plated Screw, No. 1/4-20 x 1/2 T/C Hex Hd	No Number 03-1417-09 03-0571-00	1 2 2
2a	Union, Half - No. 5/8-18 x 3/8 Flare	16-0677-01	1
2b	Nipple Assembly, Pipe (w/Bracket)	A15924-000	1
2c	Coupling - 3/8 NPT x 3/8 Flare Brass	16-0355-00	1
2d	Valve, Water Regulator * * *	11-0198-02	1
3	Brace, Drier	A09386-000	1
4	Drier attaching parts, Index 3 and 4 Screw, No. 10-16 x 3/4 S/T * * *	02-2426-01 03-1360-01	1 1
5	Tube (Reservoir Overflow to Drip Pan)	13-0079-03	1
6	Tube (Reservoir to Freezer Inlet) attaching parts, Index 5 and 6 Clamp (Index 5) Clamp (Index 6) * * *	13-0674-09 02-0535-00 02-0694-00	1 1 2
7	Reservoir Valve Assembly, Float (Not shown)	02-2217-01 02-2217-02	1 1

Figure 8-3. Major Assemblies - Water-Cooled Models (Cont'd)

INDEX NO.	DESCRIPTION	PART NUMBER	REQ'D NUMBER
	attaching parts, Index 7		
	Wing Nut (p/o Reservoir)	No Number	1
	* * *		
8	Bracket, Mounting	A20959-000	1
	attaching parts, Index 8		
	Screw, No. 8-18 x 1/2 S/T Phil Pan Hd	03-1572-01	2
	* * *		
9	Compressor (See Figure 8-4)	18-4500-01	1
	attaching parts, Index 9		
	Grommet	18-2200-28	4
	Sleeve, Mounting	18-2200-27	4
	Lockwasher, No. 5/16 External Tooth - Carbon Steel Zinc Plated	03-1417-12	4
	Washer, Special	03-1408-24	4
	Screw, No. 5/16-18 x 1-3/4 Hex Cap	03-1405-40	4
	* * *		
10	Control, Pressure - H ² O	11-0296-00	1
11	Bracket, Utility	A27993-001	1
	O Ring	13-0617-26	1
	Bushing, Snap	12-1213-06	2
	attaching parts, Index 10 and 11		
	Nut, Pal	03-1394-00	1
	Screw, No. 10-16 x 3/4 S/T	03-1360-01	2
	* * *		
12	Covering, Tube	13-0279-00	1
13	Tube, Ice	A28042-001	1
	attaching parts, Index 12 and 13		
14	Clamp, Hose	02-0179-02	1
	* * *		
15	Cap, Freezer	13-0815-01	1
	* * *		

Figure 8-3. Major Assemblies — Water-Cooled Models (Cont'd)

INDEX NO.	DESCRIPTION	PART NUMBER	REQ'D NUMBER
16	Spout Assembly (See Figure 8-5) attaching parts, Index 16 and 17	No Number	1
17	Gasket, Spout Washer, No. 1/4 Internal Tooth - Phosphor Bronze Screw, No. 1/4-20 x 1 Soc-Hd Cap * * *	13-0679-00 03-1417-07 03-1544-03	1 2 2
18	Freezer Assembly (See Figure 8-6) attaching parts, Index 18 Lockwasher, No. 5/16 External Tooth - Carbon Steel Zinc Plated Screw, No. 5/16-18 x 3/4 Hex Cap * * *	No Number 03-1417-12 03-1420-04	1 3 3
19	Coupling * * *	15-0575-01	1
20	Pan, Drip * * *	A18153-000	1
21	Gasket * * *	13-0628-00	1
22	Drivemotor Assembly (See Figure 8-7) attaching parts, Index 22 Lockwasher, No. 1/4 External Toth - Carbon Steel Zinc Plated Screw, No. 1/4-20 x 1/2 Hex Cap * * *	A31977-021 03-1417-09 03-1405-03	1 4 4
23	Bushing, Snap * * *	12-1213-10	1
24	Tube, Bin Drain * * *	No Number	1

Figure 8-3. Major Assemblies — Water-Cooled Models (Cont'd)

INDEX NO.	DESCRIPTION	PART NUMBER	REQ'D NUMBER
25	Tube, Tygon attaching parts, Index 24, 25, 26 Clamp Hose * * *	13-0674-06 02-1338-00	1 2
26	Drain, Bin	A27018-001	1
27	O-Ring attaching parts, Index 26, 27, 28 to 32	13-0617-11	1
28	Top, Drain (Screws into Index 26) * * *	02-1741-00	1
29	Grommet * * *	13-0557-01	1
30	Pad, Sealing * * *	13-0806-01	1
31	Retainer, Insulation attaching parts, Index 31 Screw, No. 8 x 1/2 T/F Tap * * *	No Number 03-1404-09	1 3
32	Bin Storage * * *	02-2762-02	1
	NOTE: See Figure 8-8 for replacement parts within the Control Box Assembly.		

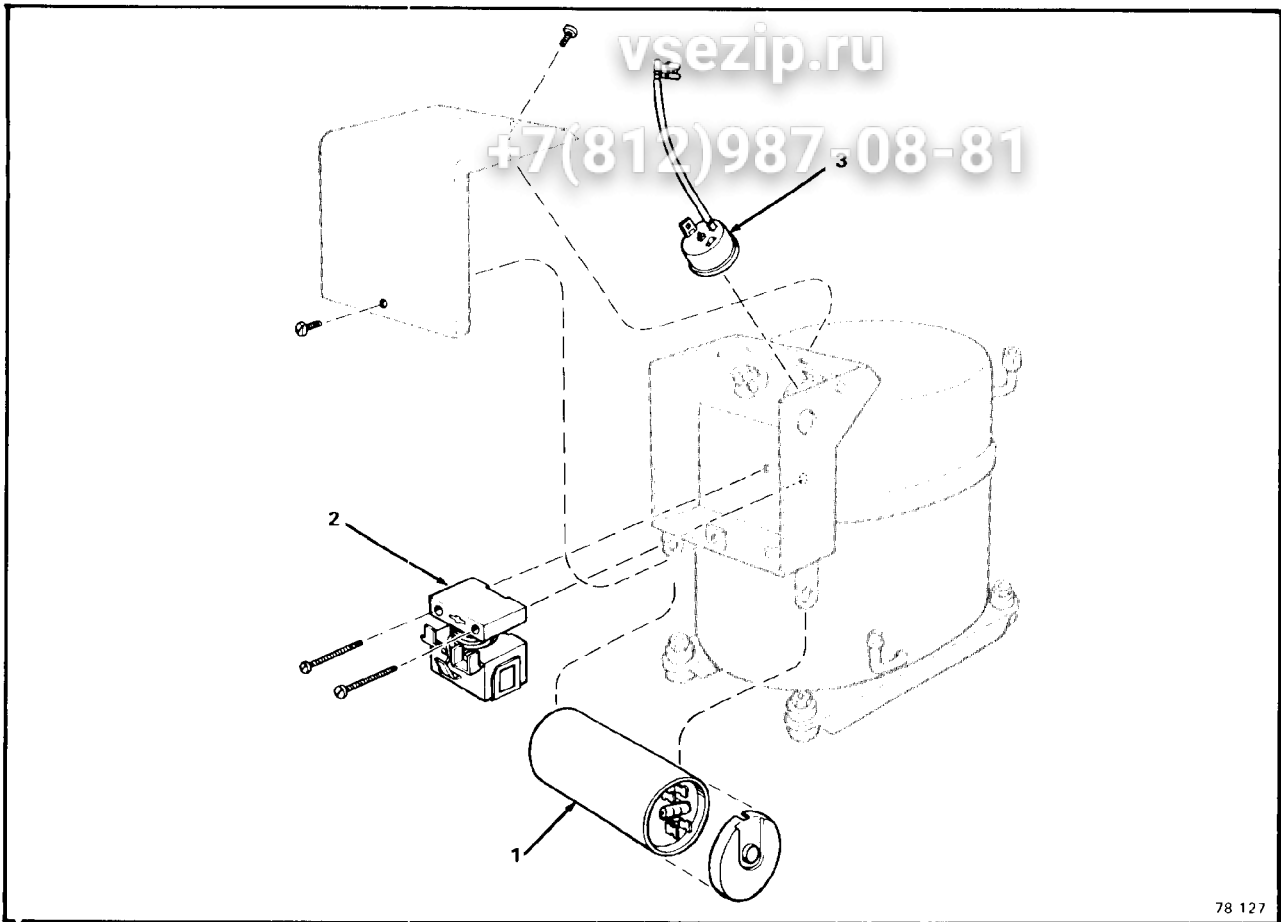

Figure 8-4. Compressor Assembly

Figure 8-4. Compressor Assembly

INDEX NO.	DESCRIPTION	PART NUMBER	REQ'D NUMBER
	Compressor Assembly (See Figure/Index 8-2/9 and 8-3/9 for next higher Assembly) * * * *	18-4500-01	Ref.
1	Capacitor - w/cap * * * *	18-1901-33	1
2	Relay * * * *	18-2200-26	1
3	Overload * * * *	18-2200-25	1

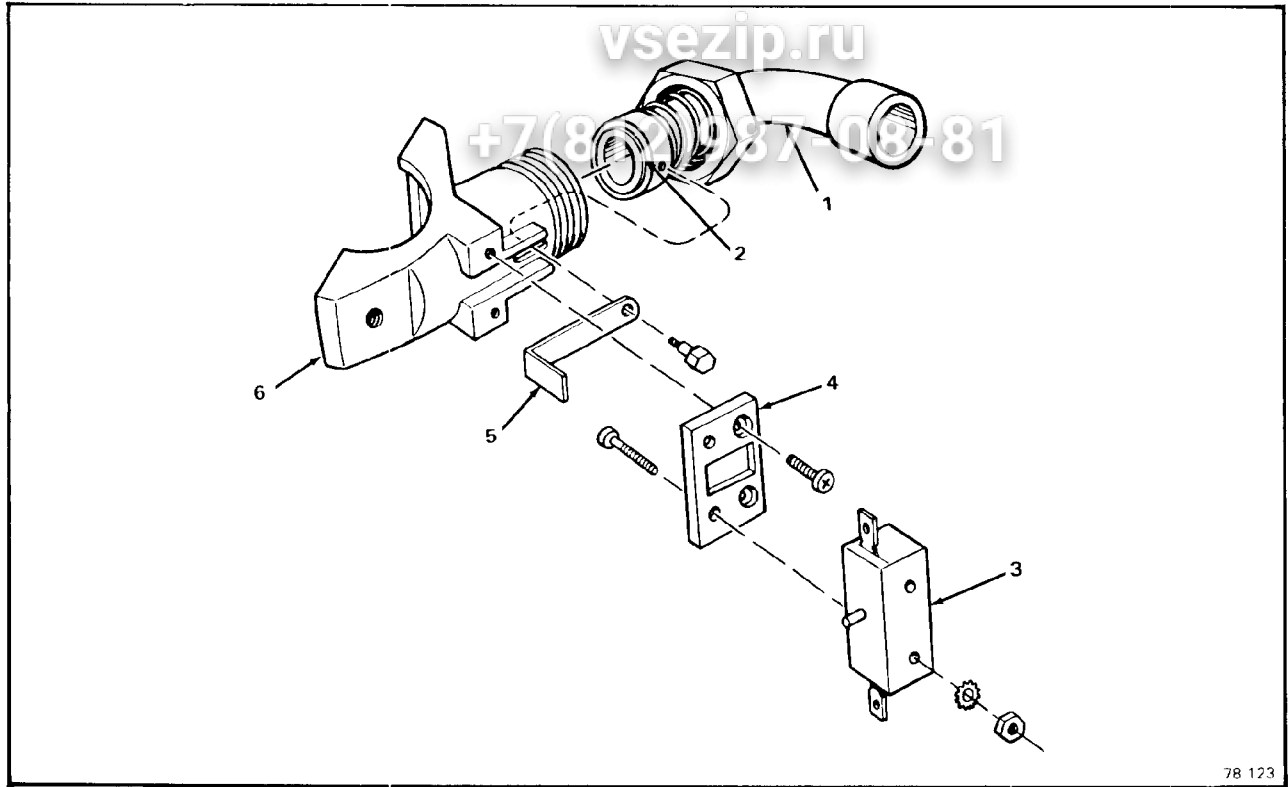

Figure 8-5. Spout Assembly.

Figure 8-5. Spout Assembly.

INDEX NO.	DESCRIPTION	PART NUMBER	REQ'D NUMBER
	Spout Assembly (See Figure/Index 8-2/16 and 8-3/16 for next higher Assembly) * * *	No Number	Ref.
1	Tube, Ice Discharge * * *	A26542-001	1
2	O-Ring * * *	13-0617-41	1
3	Switch attaching parts, Index 3 to 4	12-1664-00	1
	Screw, No. 6-32 x 1 Flat Hd. Mach - Phil Recess	03-1418-38	2

Figure 8-5. Spout Assembly (Cont'd)

INDEX NO.	DESCRIPTION	PART NUMBER	REQ'D NUMBER
	Lockwasher No. 6 External Tooth - Phosphor Bronze	03-1417-01	2
	Nut, No. 6-32 Hex Mach Screw	03-1406-01	2
	* * *		
4	Barrier, Thermal	02-2377-01	1
	attaching parts, Index 4 to 6		
	Screw, No. 6-32 x 3/8 Flat Hd Mach - Phil Recess	03-1418-01	2
	* * *		
5	Actuator, Switch	A27511-001	1
	attaching parts, Index 5 to 6		
	Screw, Shoulder	A25305-001	1
	* * *		
6	Spout	A24934-001	1
	* * *		

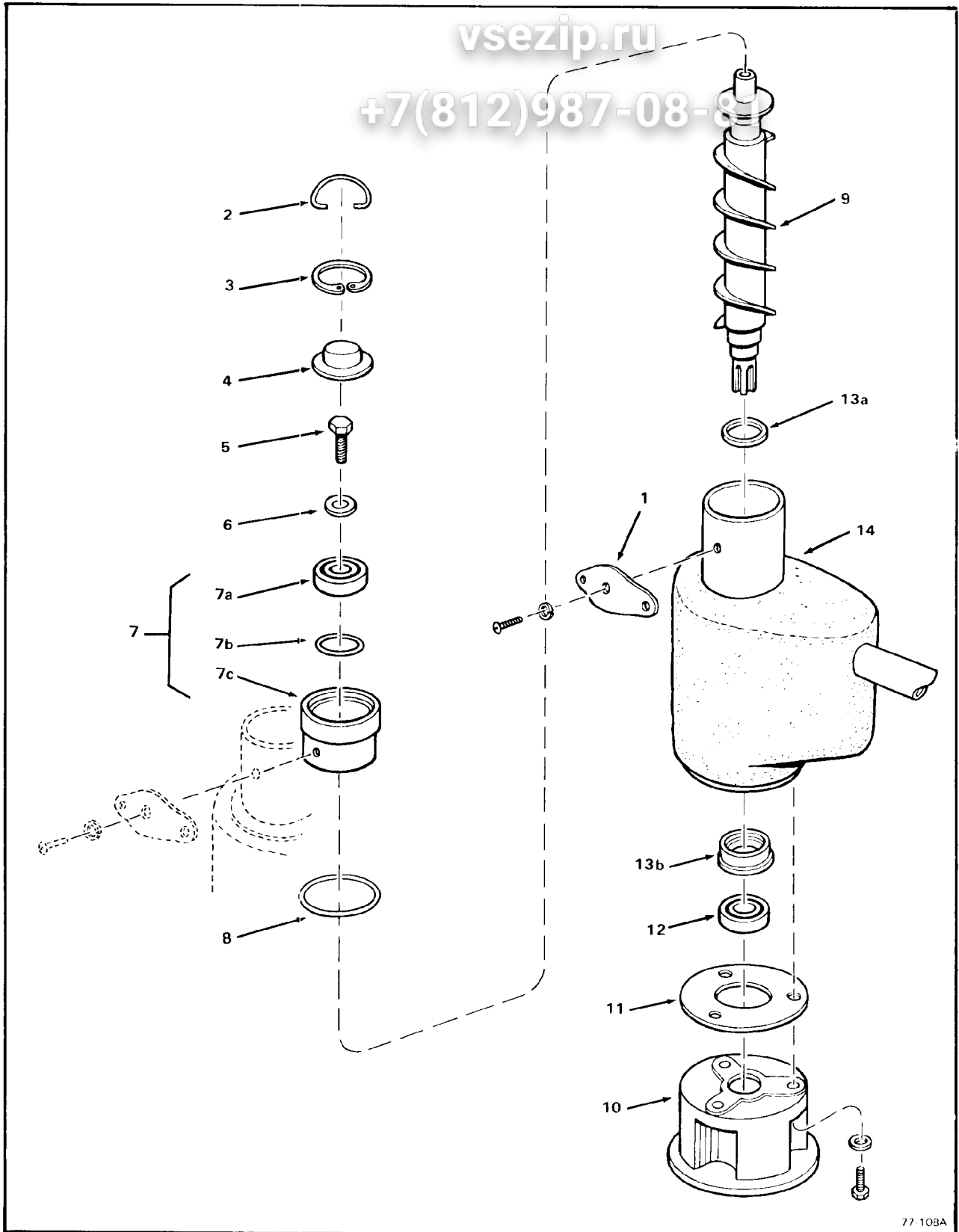

77 108A

Figure 8-6. Freezer Assembly — AF-430.

Figure 8-6. Freezer Assembly..

INDEX NO.	DESCRIPTION	PART NUMBER	REQ'D NUMBER
	Freezer Assembly (See Figure/Index 8-2/18 and 8-3/18 for next higher Assembly) * * *	No Number	Ref.
1	Plate, Spout attaching parts, Index 1 Washer, No. 3 16 Non-Metallic Screw, No. 10-24 x 3/8 Phil Recessed Hd Sealing * * *	A18430-002 03-1409-14 03-1506-01	1 1 1
2	Hook, Cap * * *	A08162-000	1
3	Ring, Retaining * * *	03-1558-03	1
4	Cap * * *	A07701-000	1
5	Screw, Cap	03-0758-00	1
6	Washer * * *	A07699-000	1
7	Bearing/Retainer - w/Bearing	A26707-001	1
7a	Bearing	02-0695-00	1
7b	O-Ring	13-0617-16	1
7c	Retainer, Bearing (Order P/N A26707-001) * * *	No Number	Ref.
8	O-Ring * * *	13-0617-29	1
9	Auger	A29622-001	1
10	Adaptor attaching parts, Index 10	08-0595-01	1

Зип Общепит

Figure 8-6. Freezer Assembly (Cont'd.)

vsezip.ru

+7(812)987-08-81

INDEX NO.	DESCRIPTION	PART NUMBER	REQ'D NUMBER
	Lockwasher, No. 5/16 Helical Spring	03-1410-04	3
	Screw, No. 5/16-18 x 7/8 Hex Cap	03-1405-42	3
	* * *		
11	Gasket	03-1505-00	1
	* * *		
12	Bearing	02-0417-00	1
	* * *		
13	Seal, Water	A18945-000	1
13a	Seal, Upper (Fits on Index 9)	No Number	Ref.
13b	Seal, Lower (Fits on top of Index 12)	No Number	Ref.
	* * *		
14	Freezer - (Repair Assembly)	A29344-020	1
	* * *		

Зип Общепит

AF430 SERVICE PARTS

GEARMOTOR

vsezip.ru

+7(812)987-08-81

ITEM NUMBER	PART NUMBER	DESCRIPTION
1.	12-2059-01	Switch
2.	A27895-001	Housing
3.	A27494-001	Centrifugal Sw. Kit
4.	03-1403-77	Screw
5.	A30579-001	Shaft and Actuator
6.	03-1408-36	Washer
7.	02-1503-00	Grease seal
8.	03-1408-21	Washer
9.	03-1408-04	Washer
10.	02-2445-01	Output shaft
11.	03-1515-03	Retaining ring
12.	03-1602-01	Woodruff Key
13.	02-2444-01	Output gear
14.	02-1505-00	O-ring
15.	03-0774-11	Roll pin
16.	A28166-001	Gear Case
17.	03-1408-39	Washer
18.	03-1408-40	Washer shim
19.	02-2439-01	Second gear and third pinion
20.	03-1408-41	Washer
21.	03-1408-38	Washer
22.	02-2438-01	First gear and second pinion
23.	A28165-021	Gear box cover
24.	02-1504-00	Grease seal
25.	02-1501-00	Bearing
26.	03-1408-08	Washer
27.	A31978-001	Rotor for A31977
28.	A28160-001	Rotor for A28151
29.	12-2302-01	Stator for A31977
30.	12-1400-01	Stator for A28151
31.	A28168-001	Fan
32.	A17047-002	Motor Housing with bearing
33.	A25835-001	Oil
34.	A31977-021	Complete Gear Mot Assembly

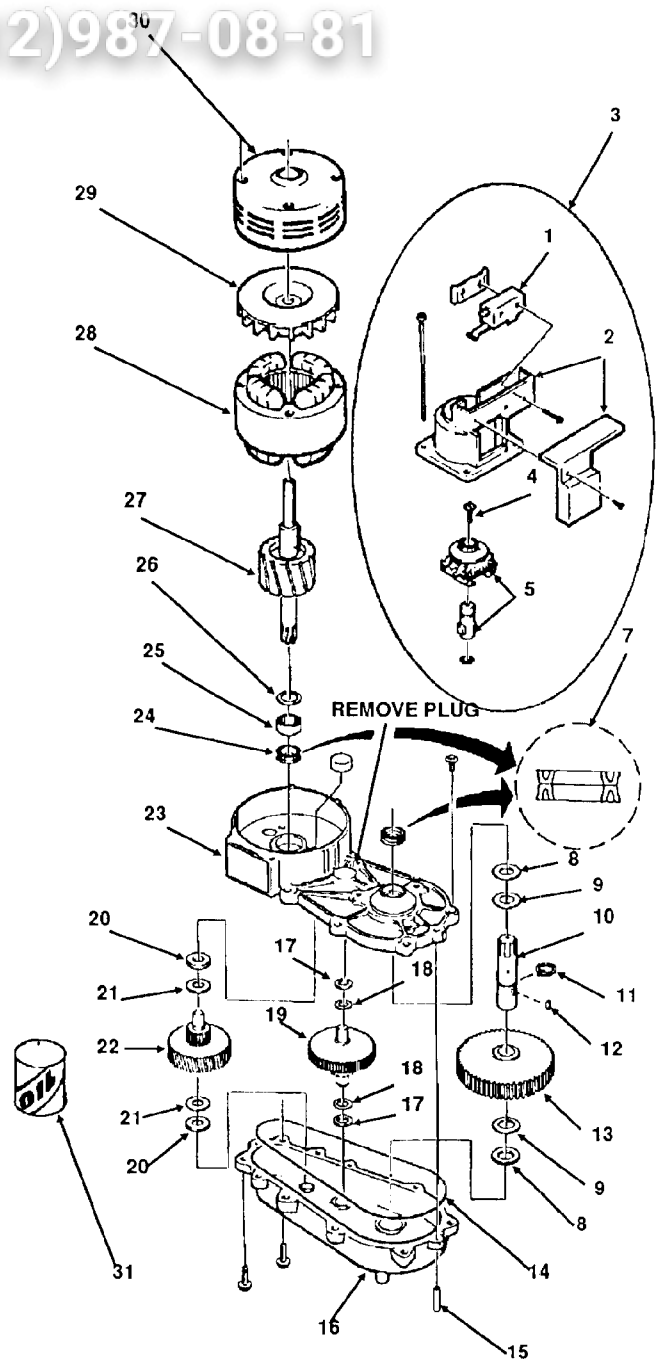

Зип Общепит

vsezip.ru

+7(812)987-08-81

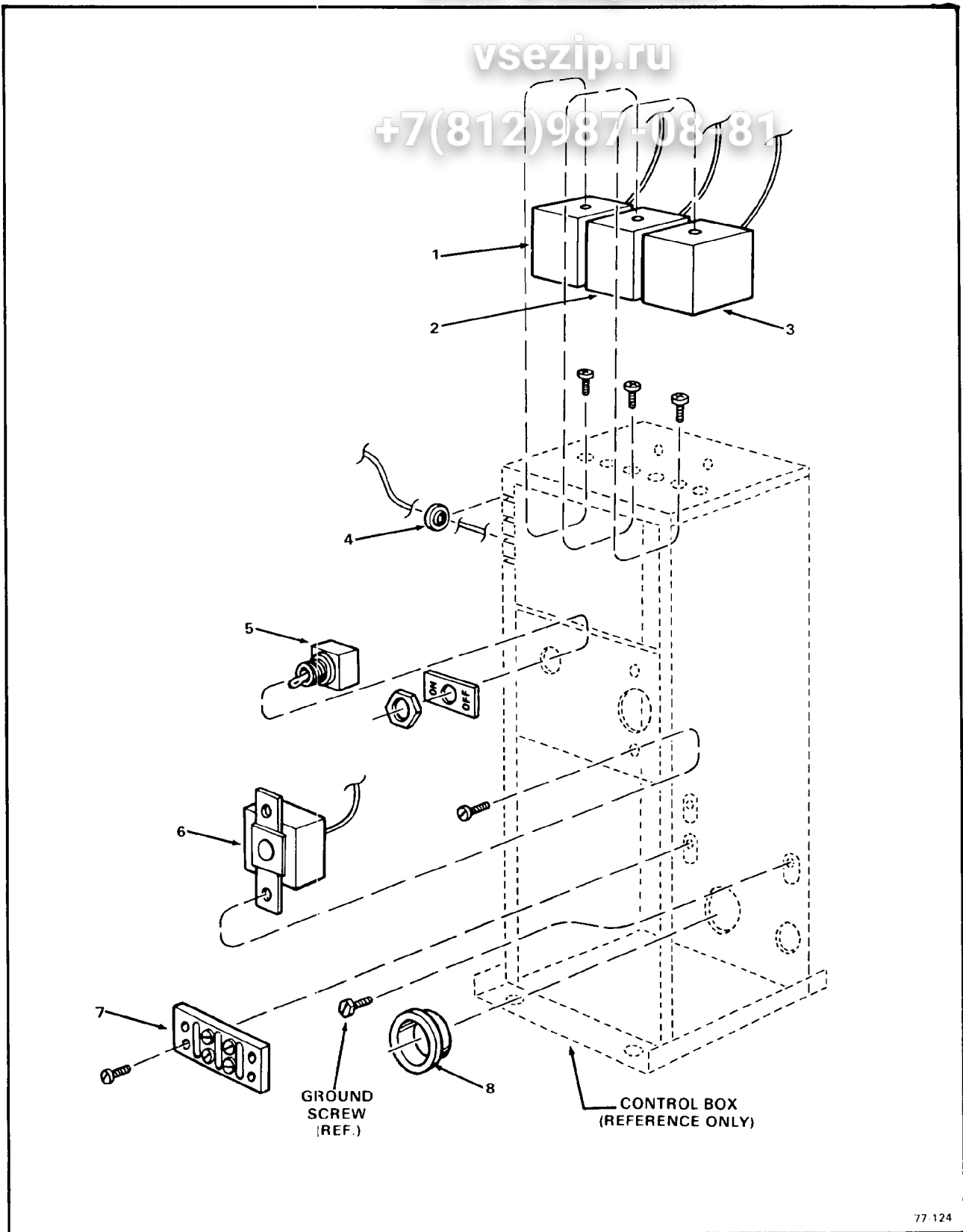

77-124

Figure 8-8. Control Box Assembly.

Figure 8-8. Control Box Assembly - AF-430.

INDEX NO.	DESCRIPTION	PART NUMBER	REQ'D NUMBER
	Control Box Assembly - AF-430 (See Figure 8-2/8-3 for next higher Assembly) * * *	No Number	Ref.
1	Control, Low-Pressure attaching parts, Index 1 Screw, No. 6-32 x 1/4 Pan Hd * * *	11-0420-01 03-1403-02	1 2
2	Control, Hi-Pressure (Water-Cooled Model) attaching parts, Index 2 Screw, No. 6-32 x 1/4 Pan Hd * * *	11-0388-02 03-1403-02	1 2
3	Control, Auger Delay attaching parts, Index 3 Screw, No. 6-32 x 1/4 Pan Hd * * *	11-0402-01 03-1403-02	1 2
4	Grommet * * *	13-0557-00	4
5	Switch, Toggle * * *	12-0426-01	1
6	Thermostat, Bin attaching parts, Index 6 Screw, No. 8-32 x 3/8 Phil Recess Pan Hd * * *	11-0354-00 03-1403-17	1 2
7	Board, Terminal attaching parts, Index 7 Screw, No. 8-32 x 3/4 Phil Recess Pan Hd * * *	12-0813-04 03-1403-21	1 2
8	Bushing, Snap * * *	12-1213-12	1

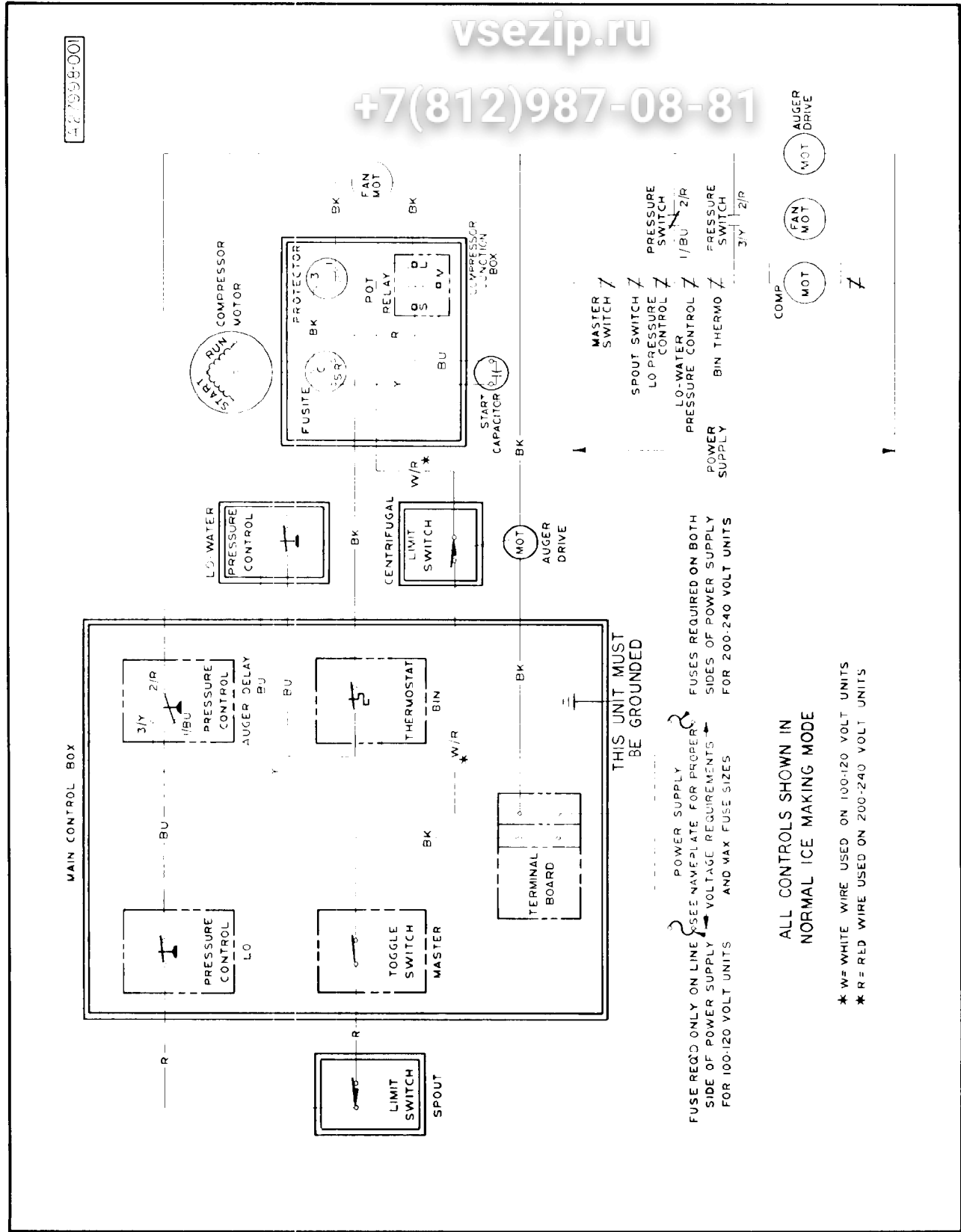

Figure 7-1. Wiring Diagram AF-430 - Air-Cooled.

vsezip.ru

+7(812)987-08-81

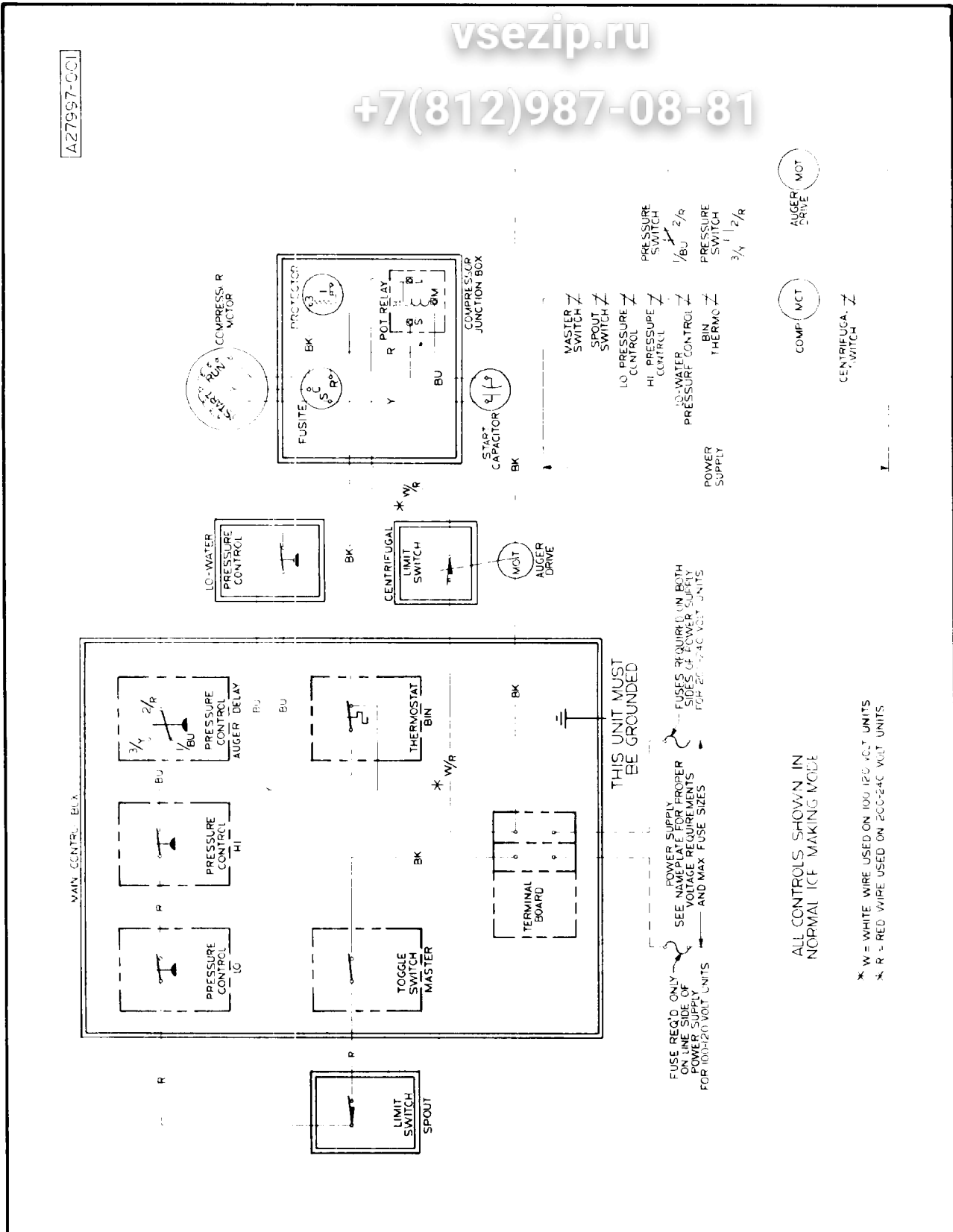

Figure 7-2. Wiring Diagram AF-430 - Water-Cooled.