



Зип Общепит
CATALOG OF
vsezip.ru

+7(812)987-08-81
REPLACEMENT PARTS



MODEL C64A SERIES DISHWASHERS

ML-103908 (R-L)

ML-103909 (L-R)

vsezip.ru

+7(812)987-08-81

vsezip.ru

+7(812)987-08-81

Table of Contents

Page	Description
5	Control Box
6	Component Panel (Control Box)
9	Wash Motor & Pump Units
11	Unit – Conveyor Drive
13	Track & Cradle (Wash/Rinse Section)
15	Wash Arms & Tubes (Wash/Rinse Section)
16	Fill & Outside Rinse Piping
19	Inside Metallic Rinse Pipe
21	Inside Rinse Piping (Non Metallic)
23	Actuator Mechanism & Rinse Drain Off Pan
25	Drain Unit (Wash/Rinse Section)
27	Doors, Curtains, Baffles, & Strainers
28	Vent Hood
29	Extended Hood
30	Miscellaneous (Wash/Rinse Section)
33	Low Water Protection (Steam Heat/Wash & Rinse Tank)
35	Electric Heat
37	Gas Heat Burners, Flues, & Wireways
38	Gas Heat Components
41	Steam Coils
43	Steam Coil Piping
45	Steam Injector & Previous Construction Steam Coil Piping
46	Steam Injector Heat
47	Dish Racks

This catalog contains parts for standard height and 6" higher than standard height. For proper identification of some parts, it is necessary to measure the door height. These parts are so noted.

DOOR HEIGHT

26 1/8 = Standard

32 1/8 = 6" Higher than Standard

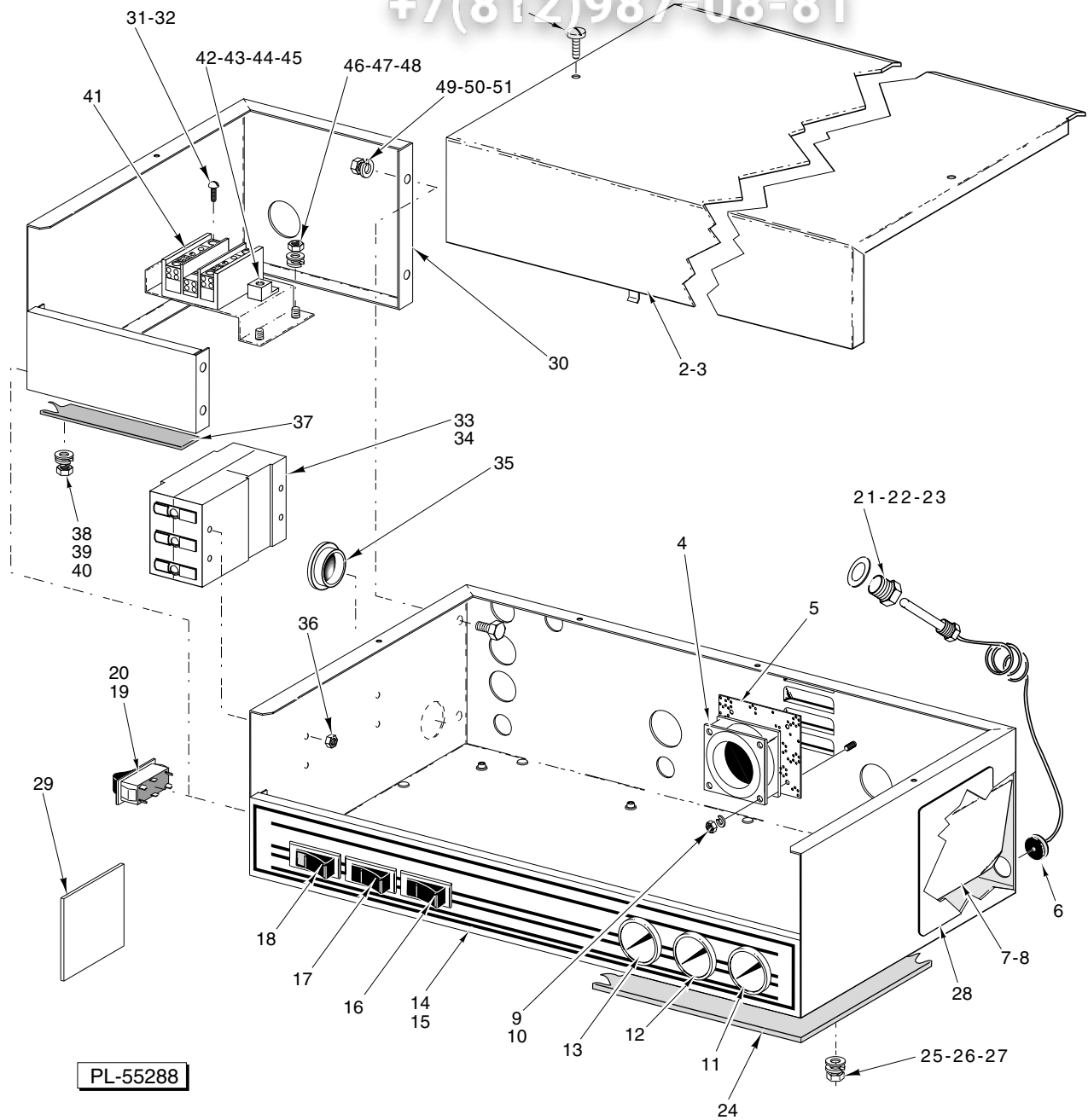

CONTROL BOX

vsezip.ru

+7(812)987-08-81
CONTROL BOX

ILLUS.	PART	NAME OF PART	AMT.
	PL-55288		
1	SC-053-05	Mach. Screw 10-24 x ³ / ₈ Truss Hd., Slotted	2
2	00-436755-00001	Cover – Control Box (W/O Single Point Electrical Connection)	1
3	00-437073-00001	Cover – Control Box (W/Single Point Electrical Connection)	1
4	00-355504-00001	Fan (115 V.)	1
5	00-274884	Guard – Fan	1
6	00-274947	Grommet	1
7	00-328137	Shield	1
8	NS-031-15	Stop Nut 10-24 Hex (SST)	2
9	WL-006-42	Lockwasher #6 Medium	3
10	NS-011-07	Mach. Nut 6-32 Hex	3
11	00-437041-00003	Thermometer (8 Ft.) (Final Rinse)	1
12	00-437041-00004	Thermometer (11 Ft.) (Rinse)	1
13	00-437041-00004	Thermometer (11 Ft.) (Wash)	1
14	00-812854	Label – Control Box (W/O Conveyor Dwell)	AR
15	00-812848	Label – Control Box (Conveyor Dwell)	AR
16	00-087711-241-2	Switch – Rocker (DPDT) (Conveyor Dwell)	1
17	00-087711-228-1	Switch – Rocker (Motor On/Off)	1
18	00-087711-198-2	Switch – Rocker (Power On/Off)	1
19	00-087711-241-2	Switch – Rocker (DPDT) (Timer)	1
20	00-271840	Label – Timer	1
21	00-107218	Coupling – Thermometer Bulb	3
22	WS-012-40	Washer	4
23	FP-053-05	Pipe Locknut ¹ / ₂ NPSL (SST)	3
24	00-435072	Gasket	1
25	WS-022-01	Washer	6
26	WL-006-17	Lockwasher ¹ / ₄ Medium	6
27	NS-015-01	Nut ¹ / ₄ -20 Hex (SST)	6
28	00-436711	Label – Instruction	1
29	00-329408	Label – Instruction (Gas Heat)	1
30	00-437068	Control Box (Single Point Electrical Connection, Elec. Heat Only)	1
31	SC-021-24	Mach. Screw 10-24 x ⁵ / ₈ Rd. Hd.	4
32	NS-031-16	Stop Nut 10-24 “Elastic” (SST)	4
33	00-276259-00002	Circuit Breaker (20 Amp.) (Used on 200-240 V. Machines)	1
34	00-276259-00004	Circuit Breaker (40 Amp.) (Used on 380-480 V. Machines)	1
35	FE-024-13	Bushing – Electrical 2 ¹ / ₂	1
36	NS-031-08	Stop Nut 8-32 “Special”	4
37	00-526408	Tape – Foam	AR
38	WL-006-17	Lockwasher ¹ / ₄ Medium	2
39	WS-017-06	Washer	2
40	NS-015-01	Nut ¹ / ₄ -20 Hex (SST)	2
41	00-119031	Block – Terminal	1
42	00-118544-00002	Lug – Grounding	1
43	SC-021-23	Mach. Screw 10-24 x ¹ / ₂ Rd. Hd.	1
44	WL-007-12	Lockwasher #10 External Shakeproof	1
45	NS-031-16	Stop Nut 10-24 “Elastic” (SST)	1
46	WL-006-17	Lockwasher ¹ / ₄ Medium	2
47	WS-022-01	Washer	2
48	NS-015-01	Nut ¹ / ₄ -20 Hex (SST)	2
49	NS-015-01	Nut ¹ / ₄ -20 Hex (SST)	4
50	WL-006-17	Lockwasher ¹ / ₄ Medium	4
51	SC-041-05	Cap Screw ¹ / ₄ -20 x ⁵ / ₈ Hex Hd.	4
	FE-021-12	Plug – ¹ / ₂ Knockout (Plastic)	AR
	FE-023-26	Plug – 1 Knockout (Plastic)	AR

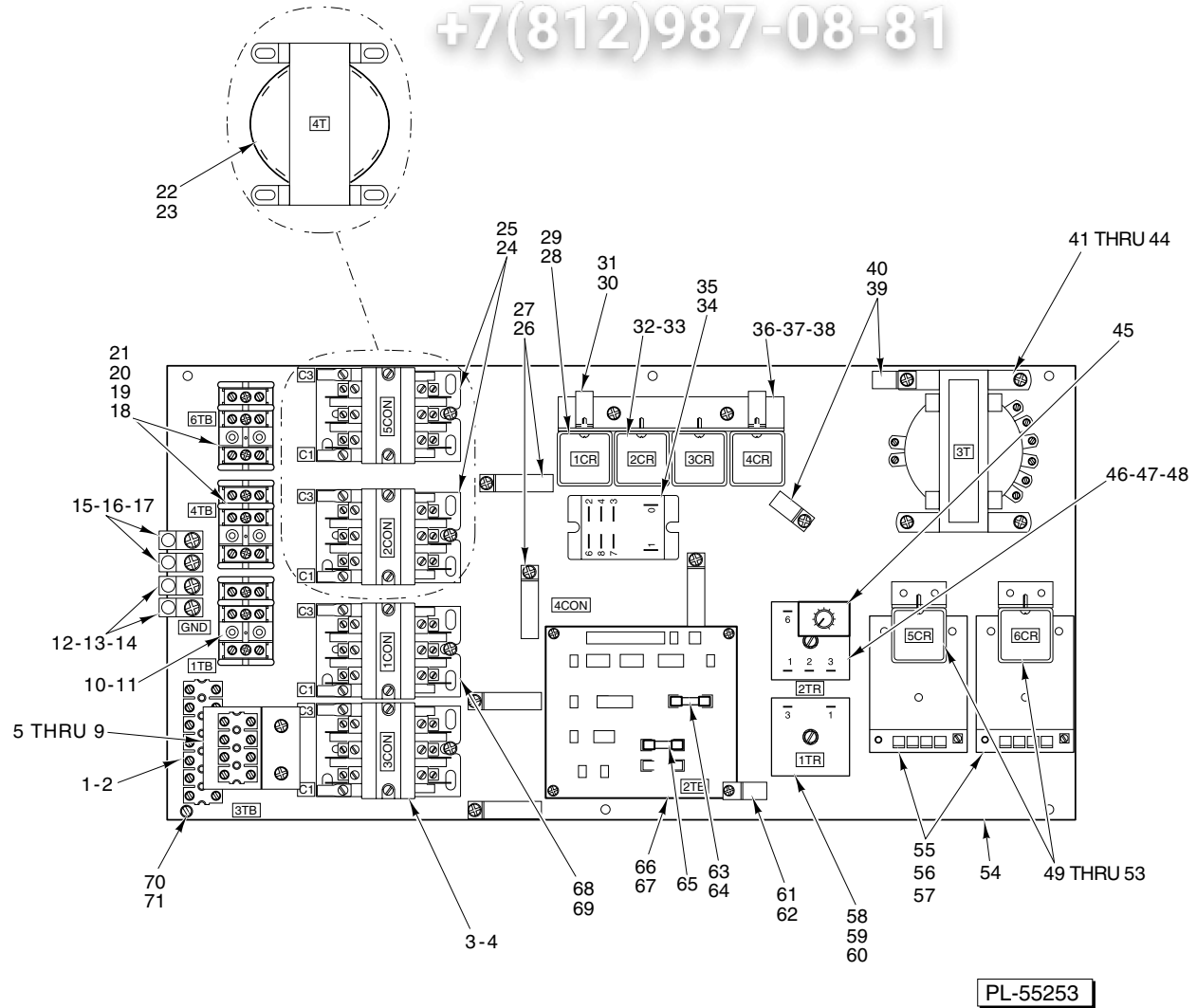

COMPONENT PANEL (CONTROL BOX)

ILLUS.	PART	NAME OF PART	AMT.
1	00-294325-013-5	Block – Terminal	1
2	SD-019-29	Self-Tapping Screw 6-20 x 1/2 Phil. Pan Hd., Type B	2
3	00-087713-041-2	Contactor (40 Amp.) (3 Pole) (Machines W/Conveyor Dwell)	1
4	SD-008-25	Self-Tapping Screw 10-16 x 3/8 Phil. Bind Hd., Type B	2
5	00-294325-013-4	Block – Terminal (Machines W/Vent Fan Control)	1
6	00-437101	Bracket – Vent Fan Control	1
7	SD-008-25	Self-Tapping Screw 10-16 x 3/8 Phil. Bind Hd., Type B	2
8	WL-014-07	Lockwasher #10 External Shakeproof (SST)	2
9	SD-019-29	Self-Tapping Screw 6-20 x 1/2 Phil. Pan Hd., Type B	2
10	00-294325-015-1	Block – Terminal	1
11	SD-037-21	Self-Tapping Screw 8-32 x 1 Fil. Phil. Hd., Type F	2

COMPONENT PANEL (CONTROL BOX)

ILLUS. PL-55253	PART	NAME OF PART	AMT.
12	00-118544-00002	Lug – Grounding	2
13	SD-035-77	Self-Tapping Screw 1/4-20 x 3/8 Phil. Pan Hd., Type TT	2
14	WL-007-15	Lockwasher 1/4 External Shakeproof	2
15	00-118544-00002	Lug – Grounding (Electric Heat)	2
16	SD-035-77	Self-Tapping Screw 1/4-20 x 3/8 Phil. Pan Hd., Type TT	2
17	WL-007-15	Lockwasher 1/4 External Shakeproof	2
18	00-294325-015-1	Block – Terminal (200-240 V., 380-480 V., 3 Ph.) (Electric Heat)	2
19	00-294325-004-1	Block – Terminal (Not Shown) (200-240 V., 1 Ph.) (Electric Heat)	2
20	SD-037-21	Self-Tapping Screw 8-32 x 1 Phil. Fil Hd., Type F (Use with Item 18)	4
21	SD-008-36	Self-Tapping Screw 8-18 x 7/8 Phil. Rd. Hd., Type B (Use with Item 19)	4
22	00-294500-026-1	Transformer (75 VA) (Gas Heat)	1
23	SD-008-25	Self-Tapping Screw 10-16 x 3/8 Phil. Bind Hd., Type B	4
24	00-087713-041-2	Contactor (40 Amp.) (3 Pole) (Electric Heat)	2
25	SD-008-25	Self-Tapping Screw 10-16 x 3/8 Phil. Bind Hd., Type B	4
26	00-294677-00005	Clamp – Wire (1 1/2 I.D.)	5
27	SD-008-25	Self-Tapping Screw 10-16 x 3/8 Phil. Bind Hd., Type B	5
28	00-205113-00001	Relay 3 P.D.T. (1CR, 3CR, & 4CR)	3
29	SD-019-29	Self-Tapping Screw 6-20 x 1/2 Phil. Pan Hd., Type B	6
30	00-294677-00004	Clamp – Wire (1 I.D.)	2
31	SD-008-25	Self-Tapping Screw 10-16 x 3/8 Phil. Bind Hd., Type B	2
32	00-087714-007-2	Relay – D.P.D.T. (115 V.)	1
33	SD-019-29	Self-Tapping Screw 6-20 x 1/2 Phil. Pan Hd., Type B	2
34	00-087714-046-1	Contactor (Machines W/Vent Fan Control)	1
35	SD-008-18	Self-Tapping Screw 8-18 x 3/8 Phil. Bind Hd., Type B	2
36	00-437103	Bracket	1
37	SD-008-25	Self-Tapping Screw 10-16 x 3/8 Phil. Bind Hd., Type B	2
38	WL-014-07	Lockwasher #10 External Shakeproof (SST)	2
39	00-294677-00004	Clamp – Wire (1 I.D.)	3
40	SD-008-25	Self-Tapping Screw 10-16 x 3/8 Phil. Bind Hd., Type B	3
41	00-294500-046-1	Transformer (150 VA) Pilot Control	1
42	00-294500-046-2	Transformer (300 VA) Pilot Control	1
43	SD-008-25	Self-Tapping Screw 10-16 x 3/8 Phil. Bind Hd., Type B	4
44	WL-014-07	Lockwasher #10 External Shakeproof (SST)	4
45	00-437070-00001	Plug-On Module	1
46	00-087714-00036	Relay Time Delay (Variable)	1
47	SD-036-13	Self-Tapping Screw 1/4-20 x 1 1/4 Slotted Hex Washer Hd., Type T	1
48	WL-007-15	Lockwasher 1/4 External Shakeproof	1
49	00-205113-00001	Relay (3 P.D.T.)	2
50	SD-019-29	Self-Tapping Screw 6-20 x 1/2 Phil. Pan Hd., Type B	4
51	00-437102	Bracket – Relay Mounting	2
52	SD-008-18	Self-Tapping Screw 10-16 x 3/8 Phil. Bind Hd., Type B	4
53	WL-014-05	Lockwasher #8 External Shakeproof	4
54	00-435508	Base Plate	1
55	00-475458-00001	Thermostat – Solid State (120 V.)	2
56	SC-098-07	Mach. Screw 4-40 x 1 3/4 Rd. Hd. (SST)	6
57	WS-028-12	Washer	2
58	00-087714-031-2	Relay Time Delay (5 Sec.)	1
59	SD-036-13	Self-Tapping Screw 1/4-20 x 1 1/4 Slotted Hex Washer Hd., Type T	1
60	WL-007-15	Lockwasher 1/4 External Shakeproof	1
61	00-294677-00003	Clamp – Wire	1
62	SD-019-31	Self-Tapping Screw 8-18 x 1/2 Phil. Pan Hd., Type B	1
63	FE-022-39	Fuse (1.5 Amp.) (250 V.) (60 Hz. Machines W/O Blower Dryer or Condenser)	1
64	FE-021-19	Fuse (3.2 Amp.) (250 V.) (50 Hz. & 50/60 Hz. Machines W/Blower Dryer &/or Condenser)	1
65	FE-023-80	Fuse (3.0 Amp.) (250 V.) (Gas Heat)	1
66	00-294676	P.C.B. – Terminal & Fuse	1
67	SD-008-18	Self-Tapping Screw 8-18 x 3/8 Phil. Bind Hd., Type B	3
68	00-087713-041-2	Contactor (40 Amp.) (3 Pole)	1
69	SD-008-25	Self-Tapping Screw 10-16 x 3/8 Phil. Bind Hd., Type B	2
70	SC-053-05	Mach. Screw 10-24 x 3/8 Truss Hd., Slotted	6
71	WL-007-12	Lockwasher #10 External Shakeproof	6

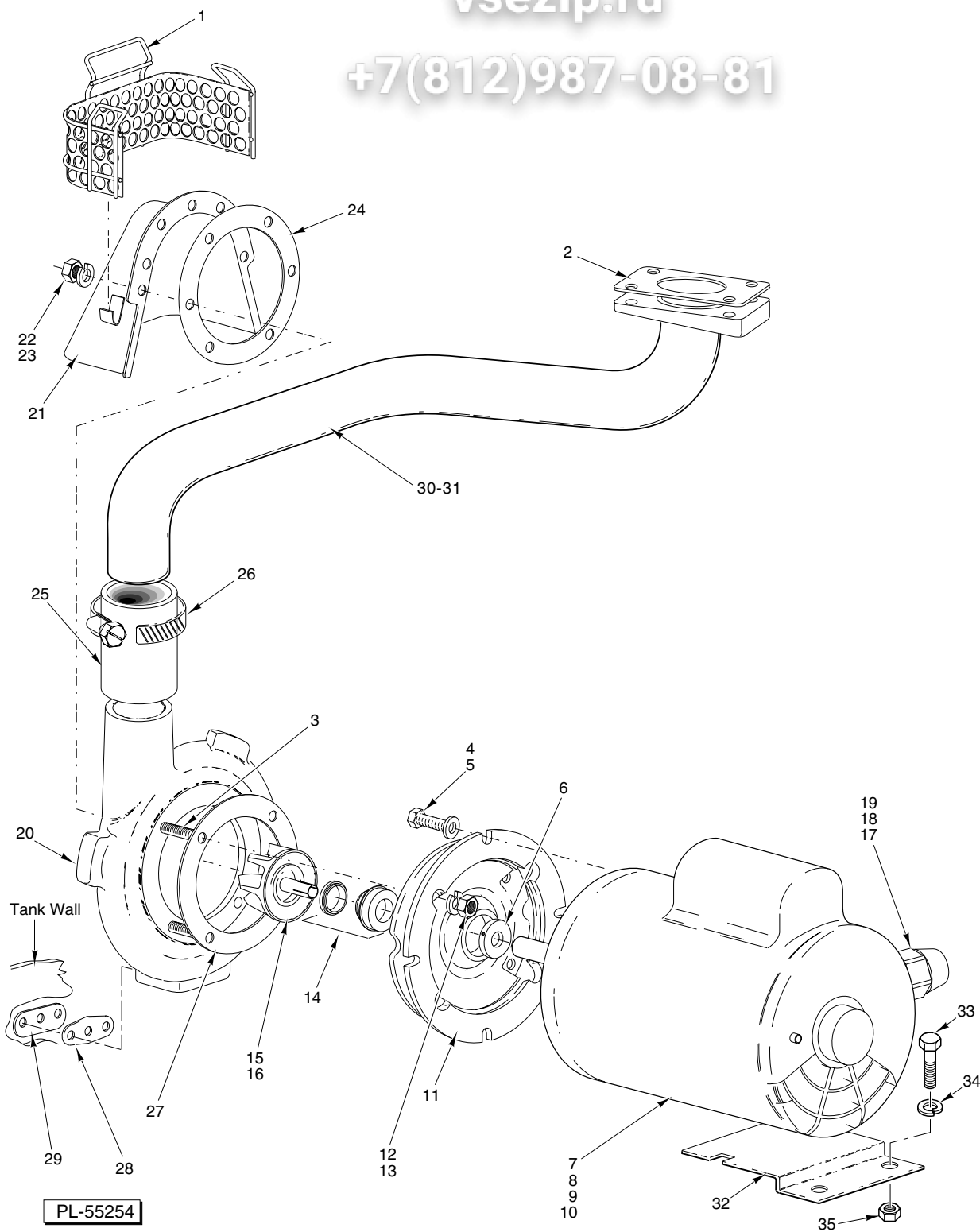

**WASH MOTOR & PUMP UNITS
(2 UNITS REQUIRED)**

vsezip.ru

+7(812)987-08-81

**WASH MOTOR & PUMP UNITS
(2 UNITS REQUIRED)**

ILLUS.	PART	NAME OF PART	AMT.
PL-55254			
1	00-328362	Strainer – Pump	1
2	00-270968	Gasket – Wash Pipe	1
3	00-274227-00005	Stud	AR
4	SC-041-29	Cap Screw ³ / ₈ -16 x ⁷ / ₈ Hex Hd. (SST)	4
5	WS-006-44	Washer	4
6	00-274227-00002	Clamp	1
7	00-274230-00001	Motor (1 Ph., 60 Hz.) (2 HP)	1
8	00-274230-00002	Motor (3 Ph., 60 Hz.) (2 HP)	1
9	00-274230-00003	Motor (1 Ph., 50 Hz.) (2 HP)	1
10	00-274230-00004	Motor (3 Ph., 50 Hz.) (2 HP)	1
11	00-274227-00003	Adapter	1
12	WL-006-22	Lockwasher ⁵ / ₁₆ Light	4
13	NS-015-11	Nut ⁵ / ₁₆ -18 Hex	4
14	00-274227-00006	Seal – Shaft	1
15	00-274227-00012	Impeller & Sleeve (60 Hz.)	1
16	00-274227-00007	Impeller & Sleeve (50 Hz.)	1
17	FE-024-61	Connector 45 Deg. (Non Metallic) “Sealtite”	AR
		(¹ / ₂ Male Thd. x ¹ / ₂ Flex. Cnd.)	
18	FE-024-57	Connector Straight (Non Metallic) “Sealtite”	AR
		(¹ / ₂ Male Thd. x ¹ / ₂ Flex. Cnd.)	
19	FE-008-10	¹ / ₂ Gasket Assy.	1
20	00-274227-00001	Pump Shell (Incls. Item 3)	1
21	00-274246	Shroud	1
22	WL-006-23	Lockwasher ⁵ / ₁₆ Medium (SST)	10
23	NS-015-11	Nut ⁵ / ₁₆ -18 Hex	10
24	00-119050	Gasket	1
25	00-749586	Hose – Discharge	1
26	00-542337	Clamp – Hose	2
27	00-274227-00004	Gasket	1
28	00-119051	Gasket	2
29	00-812776	Support Plate	2
30	00-328411	Tube – Discharge (RH) (Shown)	1
31	00-328409	Tube – Discharge (LH)	1
32	00-812069	Bracket – Motor Support	1
33	SC-041-05	Cap Screw ¹ / ₄ -20 x ⁵ / ₈ Hex Hd. (SST)	2
34	WL-006-17	Lockwasher ¹ / ₄ Medium	2
35	NS-015-01	Nut ¹ / ₄ -20 Hex (SST)	2

vsezip.ru

+7(812)987-08-81

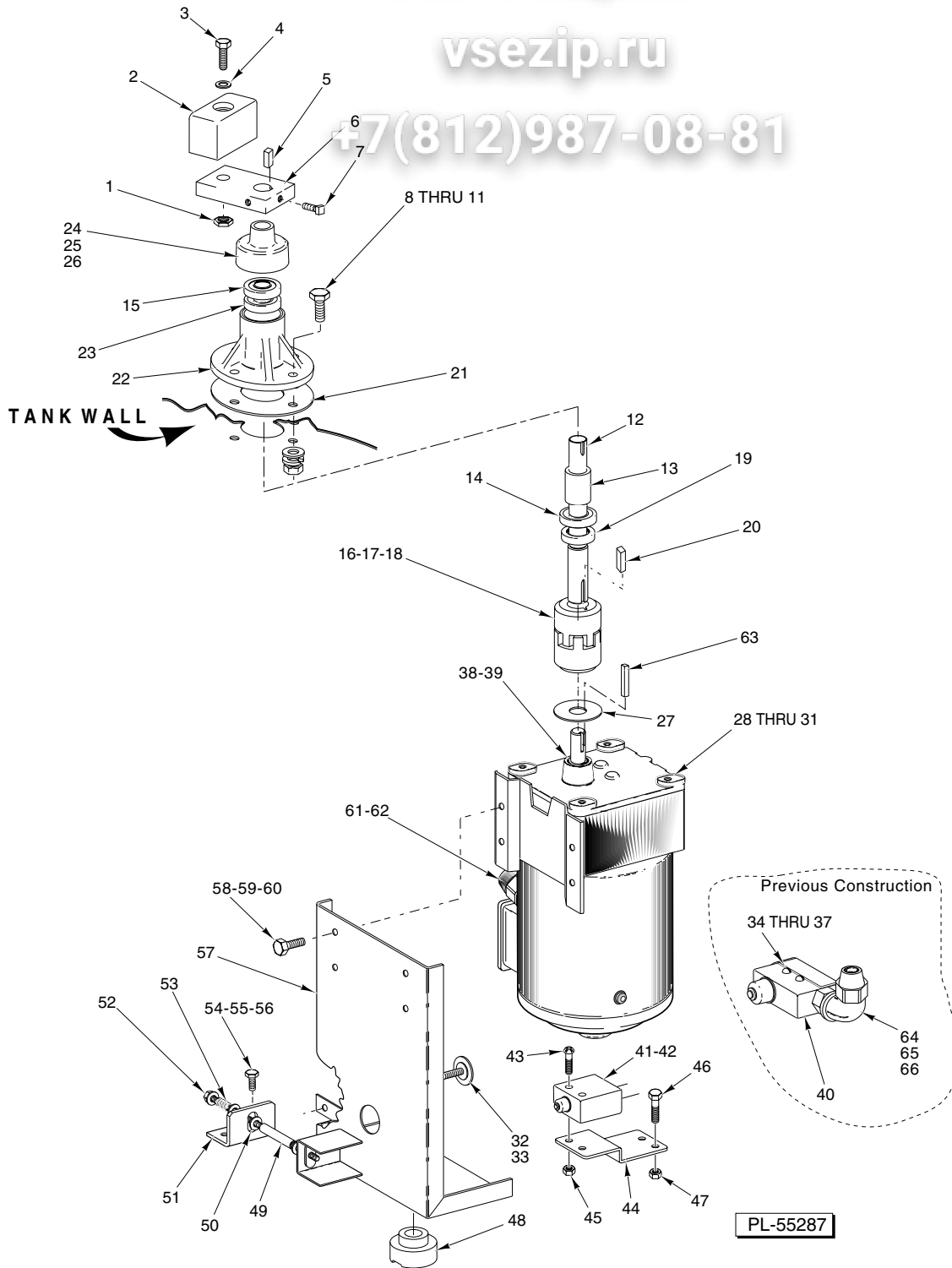

UNIT – CONVEYOR DRIVE

ILLUS.	PART	NAME OF PART	AMT.
PL-55287			
1	NS-032-35	Stop Nut $\frac{5}{16}$ -18 "Flexloc"	1
2	00-474660	Slider – Crank Arm	1
3	SC-041-20	Mach. Screw $\frac{5}{16}$ -18 x 2 $\frac{1}{8}$ Truss Hd.	1
4	NS-005-72	Washer	1
5	00-012430-00039	Key $\frac{3}{16}$ Sq. x $\frac{3}{8}$ Lg.	1

UNIT – CONVEYOR DRIVE

ILLUS.	PART	NAME OF PART	AMT.
	PL-55287		
6	00-270943	Arm – Crank.....	1
7	SC-050-01	Set Screw 1/8-20 x 1/2 Square Hd. Cup Pt.....	2
8	SC-041-13	Cap Screw 5/16-18 x Hex Hd. (SST).....	4
9	WS-017-18	Washer.....	4
10	WL-006-23	Lockwasher 5/16 Medium (SST).....	4
11	NS-015-11	Nut 5/16-18 Hex.....	4
12	00-270937	Shaft – Crank.....	1
13	00-436879	Spacer – Bearing.....	1
14	BB-021-19	Ball Bearing – Hoover NSK 6003.....	1
15	00-270940	Seal – Upper Housing.....	1
16	00-328083	Coupling – Motor.....	1
*17	00-274228-00002	Insert – Coupling Service (Lovejoy).....	AR
*18	00-274228-00001	Insert – Coupling Service (Browning).....	AR
19	00-270939	Seal – Lower Housing.....	1
20	00-012430-00040	Key 3/16 Sq. x 3/4 Lg.....	1
21	00-270942	Gasket.....	1
22	00-274749	Housing Assy. (Incls. Items 12 thru 15, 19, 23, & 24).....	1
23	BB-021-19	Ball Bearing – Hoover NSK 6003.....	1
24	00-274748	Seal – Labyrinth.....	1
25	00-527042	Adhesive.....	AR
26	00-522696	Solvent.....	AR
27	00-474423	Flinger.....	1
28	00-437044-00006	Motor – Conveyor Drive (200-230/460 V., 60 Hz.) (3 Ph.) (Incls. Items 38, 39, & 63).....	1
29	00-437044-00007	Motor – Conveyor Drive (200-240 V., 60 Hz., 1 Ph.) (Incls. Items 38, 39, & 63).....	1
30	00-437044-00008	Motor – Conveyor Drive (200-240 V., 50 Hz., 1 Ph.) (Incls. Items 38, 39, & 63).....	1
31	00-437044-00009	Motor – Conveyor Drive (220-240/380-415 V., 50 Hz., 3 Ph.) (Incls. Items 38, 39, & 63).....	1
32	00-289256	Actuator – Switch.....	1
33	NS-032-33	Stop Nut 1/4-28 “Flexloc”.....	1
34	SC-027-24	Mach. Screw 6-32 x 1 1/2 Rd. Hd.....	2
35	WL-010-22	Lockwasher #6 External Shakeproof.....	2
36	WS-002-06	Washer.....	4
37	NS-010-06	Mach. Nut 6-32 Hex.....	2
38	00-328379-00001	Seal – Oil (Output Shaft-Shown).....	1
39	00-328379-00002	Seal – Oil (Motor Drive Shaft).....	1
40	00-087711-060-1	Switch – Interlock (Incls. Items 34 thru 37).....	1
41	00-087711-00260	Switch – Interlock (Incls. Items 42 thru 46).....	1
42	FE-022-84	Strain Relief.....	1
43	SC-127-89	Mach. Screw 10-24 x 3/4 Phil. Rd. Hd. (SST).....	2
44	00-474488	Bracket – Switch.....	1
45	NS-031-16	Stop Nut 10-24 “Elastic” (SST).....	2
46	SC-067-05	Mach. Screw 8-32 x 1/2 Hex Hd. (SST).....	2
47	NS-031-08	Stop Nut 8-32 Hex (SST).....	2
48	00-270927	Pilot Bearing.....	1
49	00-271083	Spacer – Overload.....	1
50	WS-029-5	Washer.....	4
51	00-436017	Bracket – Overload.....	1
52	SC-120-72	Cap Screw 5/16-18 x 4 1/2 Hex Hd.....	1
53	00-436952	Spring – Overload.....	1
54	SC-041-11	Cap Screw 5/16-18 x 3/4 Hex Hd. (SST).....	2
55	WL-006-23	Lockwasher 5/16 Medium (SST).....	2
56	NS-015-11	Nut 5/16-18 Hex.....	2
57	00-328027	Bracket – Motor.....	1
58	SC-041-31	Cap Screw 3/8-16 x 1 1/4 Hex Hd.....	4
59	WL-006-29	Lockwasher 3/8 Hi-Collar.....	4
60	NS-015-13	Nut 3/8-16 Hex (SST).....	4
61	FE-024-61	Connector 45 Deg. (Non Metallic) “Sealtite” (1/2 Male Thd. x 1/2 Flex. Cnd.).....	1
62	FE-024-65	Connector 90 Deg. (Non Metallic) “Sealtite” (1/2 Male Thd. x 1/2 Flex. Cnd.).....	1
63	00-274231-00057	Key – 3/16 x 3/16 x 1 1/8 Lg.....	1
64	FE-024-57	Connector Straight (Non Metallic) “Sealtite” (1/2 Male Thd. x 1/2 Flex. Cnd.).....	1
65	FE-024-61	Connector 45 Deg. (Non Metallic) “Sealtite” (1/2 Male Thd. x 1/2 Flex. Cnd.).....	1
66	FE-008-10	1/2 Gasket Assy.....	1

*Parts must be matched with same vendor coupling.

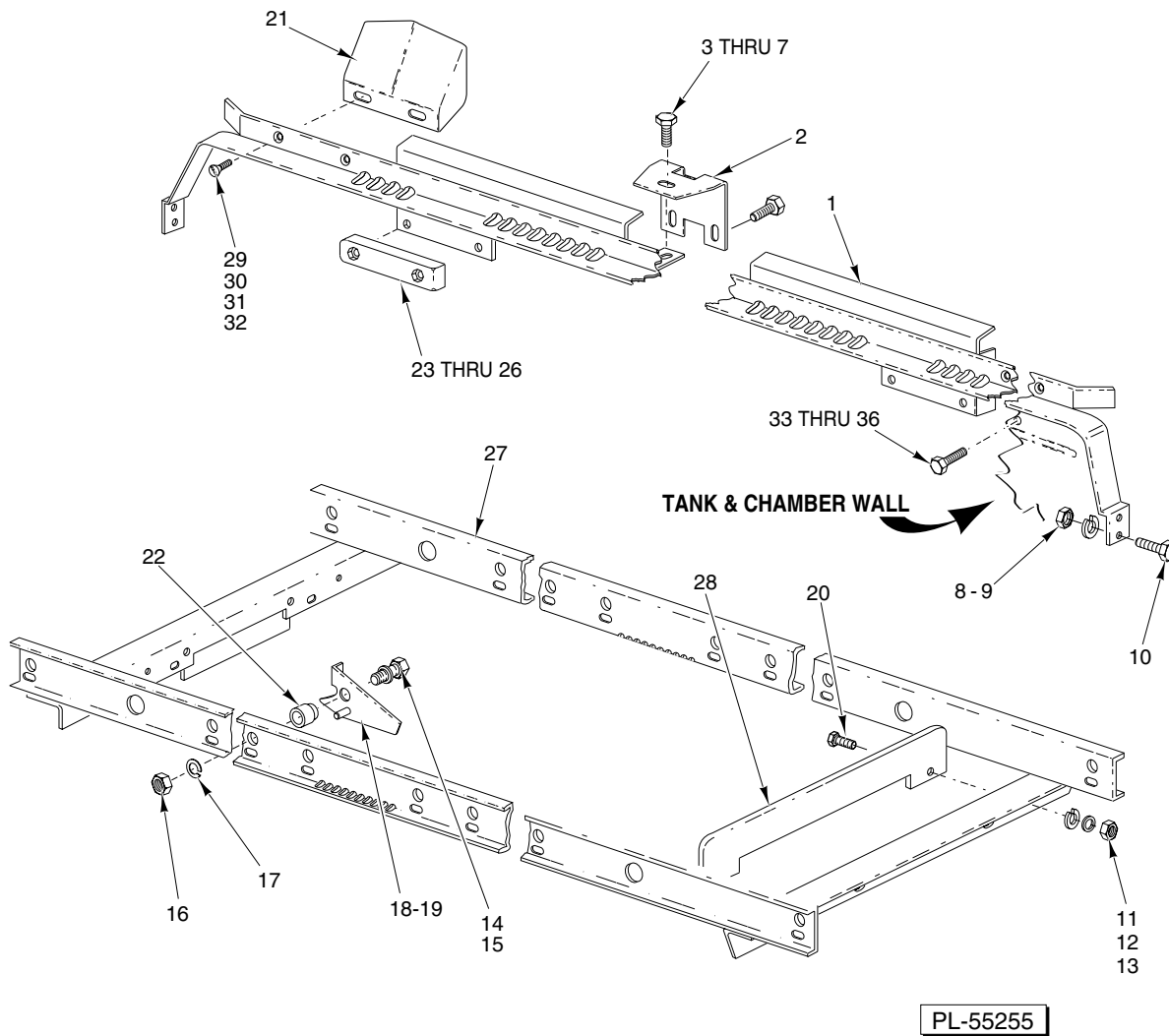

**TRACK & CRADLE
(WASH/RINSE SECTION)**

vsezip.ru

+7(812)987-08-81

**TRACK & CRADLE
(WASH/RINSE SECTION)**

ILLUS. PL-55255	PART	NAME OF PART	AMT.
1	00-435935-00001	Rack Track	2
2	00-435975	Bracket – Track	2
3	SC-041-12	Cap Screw ⁵ / ₁₆ -18 x ⁷ / ₈ Hex Hd.	6
4	WS-017-08	Washer	4
5	WS-017-01	Washer	4
6	WL-006-23	Lockwasher ⁵ / ₁₆ Medium (SST)	6
7	NS-015-11	Nut ⁵ / ₁₆ -18 Hex	6
8	NS-015-11	Nut ⁵ / ₁₆ -18 Hex	8
9	WL-006-23	Lockwasher ⁵ / ₁₆ Medium (SST)	8
10	SC-041-11	Cap Screw ⁵ / ₁₆ -18 x ³ / ₄ Hex Hd. (SST)	8
11	NS-015-11	Nut ⁵ / ₁₆ -18 Hex	AR
12	WS-017-08	Washer	AR
13	WL-006-23	Lockwasher ⁵ / ₁₆ Medium (SST)	AR
*14	WS-018-04	Washer	8
*15	SC-041-31	Cap Screw ³ / ₈ -16 x 1 ¹ / ₄ Hex Hd.	8
*16	NS-046-09	Nut ³ / ₈ -16 Hex (SST)	8
*17	WL-006-28	Lockwasher ³ / ₈ Medium	8
*18	00-436704-00001	Dog (Front, R-L) (Rear, L-R)	4
*19	00-436704-00002	Dog – Not Shown (Front, L-R) (Rear, R-L)	4
20	SC-041-10	Cap Screw ⁵ / ₁₆ -18 x ⁵ / ₈ Hex Hd.	AR
21	00-437047	Deflector – Silverware	AR
*22	00-270983	Spacer	8
23	00-473231	Slider – Large	4
24	SC-041-15	Cap Screw ⁵ / ₁₆ -18 x 1 ¹ / ₄ Hex Hd.	8
25	WL-006-23	Lockwasher ⁵ / ₁₆ Medium (SST)	8
26	NS-015-11	Nut ⁵ / ₁₆ -18 Hex	8
27	00-435938	Cradle	1
28	00-271012	Baffle – Cradle Upper	AR
29	SC-127-91	Mach. Screw ¹ / ₄ -20 x ⁵ / ₈ Flat Hd. (SST)	AR
30	WS-003-47	Washer	AR
31	WL-006-17	Lockwasher ¹ / ₄ Medium	AR
32	NS-015-01	Nut ¹ / ₄ -20 Hex (SST)	AR
33	SC-041-11	Cap Screw ⁵ / ₁₆ -18 x ³ / ₄ Hex Hd. (SST)	14
34	WS-017-01	Washer	18
35	WL-006-23	Lockwasher ⁵ / ₁₆ Medium (SST)	18
36	NS-015-11	Nut ⁵ / ₁₆ -18 Hex	18
	00-435937-00001	Cradle & Dog Assy. L-R (Standard Racks Only)	1
		(Incls. Items 14 thru 19, 22, & 27)	
	00-435937-00003	Cradle & Dog Assy. R-L (Standard Racks Only)	1
		(Incls. Items 14 thru 19, 22, & 27)	
	00-437057-00001	Rack Track Assy. (Incls. Items 1 & 23 thru 26)	2

*Quantities listed are for 20 x 20 racks.

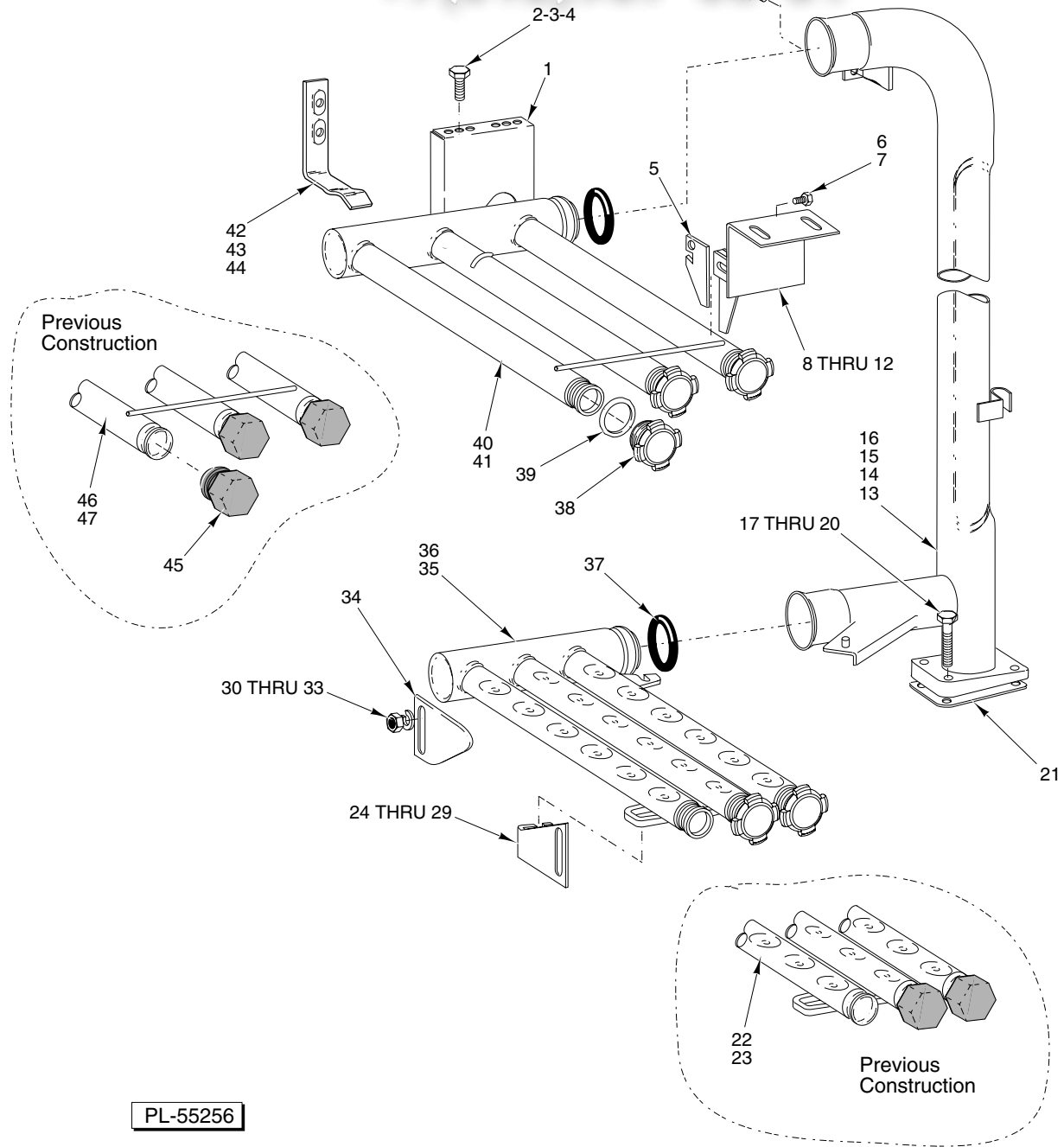

**WASH ARMS & TUBES
(WASH/RINSE SECTION)**

WASH ARMS & TUBES
(WASH/RINSE SECTION) 08-81

ILLUS.	PART	NAME OF PART	AMT.
PL-55256			
1	00-436007	Guide – Upper Wash Arm	2
2	SC-125-27	Mach. Screw $\frac{5}{16}$ -18 x $\frac{3}{4}$ Truss Hd. (SST)	4
3	WS-017-01	Washer	4
4	NS-036-19	Stop Nut $\frac{5}{16}$ -18 Hex	4
5	00-289760	Latch	2
6	SC-041-01	Cap Screw $\frac{1}{4}$ -20 x $\frac{3}{4}$ Hex Hd.	4
7	NS-031-19	Stop Nut $\frac{1}{4}$ -20 "Elastic" (SST)	4
8	00-812819	Bracket	2
9	SC-053-17	Mach. Screw $\frac{5}{16}$ -18 x $\frac{3}{4}$ Truss Hd. (SST)	4
10	WS-017-08	Washer	4
11	WL-006-23	Lockwasher $\frac{5}{16}$ Medium (SST)	4
12	NS-015-11	Nut $\frac{5}{16}$ -18 Hex	4
13	00-435999	Wash Pipe (26 $\frac{1}{8}$ Door Height) (RH)	1
14	00-435987	Wash Pipe (26 $\frac{1}{8}$ Door Height) (LH)	1
15	00-437134	Wash Pipe (32 $\frac{1}{8}$ Door Height) (RH)	1
16	00-437136	Wash Pipe (32 $\frac{1}{8}$ Door Height) (LH)	1
17	SC-041-18	Cap Screw $\frac{5}{16}$ -18 x $1 \frac{3}{4}$ Hex Hd. (SST)	8
18	WS-017-08	Washer	16
19	WL-006-23	Lockwasher $\frac{5}{16}$ Medium (SST)	8
20	NS-015-11	Nut $\frac{5}{16}$ -18 Hex	8
21	00-270968	Gasket – Wash Pipe	2
*22	00-436002	Wash Arm – Lower (RH) (Shown)	1
*23	00-436000	Wash Arm – Lower (LH)	1
24	00-436939-00002	Catch – Adjustable (RH) (Shown)	1
25	00-436939-00001	Catch – Adjustable (LH)	1
26	NS-015-11	Nut $\frac{5}{16}$ -18 Hex	4
27	WL-006-23	Lockwasher $\frac{5}{16}$ Medium (SST)	4
28	WS-017-8	Washer	4
29	SC-041-11	Cap Screw $\frac{5}{16}$ -18 x $\frac{3}{4}$ Hex Hd. (SST)	4
30	SC-041-11	Cap Screw $\frac{5}{16}$ -18 x $\frac{3}{4}$ Hex Hd. (SST)	4
31	WL-006-23	Lockwasher $\frac{5}{16}$ Medium (SST)	4
32	WS-017-08	Washer	4
33	NS-015-11	Nut $\frac{5}{16}$ -18 Hex	4
34	00-274222	Support – Adjustable	2
35	00-749416	Wash Arm – Lower (RH) (Shown)	1
36	00-749415	Wash Arm – Lower (LH)	1
37	00-067500-00110	"O" Ring	4
38	00-475589	Plug – Wash Arm (Used With Items 35, 37, 43, & 44)	12
39	00-067500-00127	"O" Ring	12
40	00-749419	Wash Arm – Upper (RH) (Shown)	1
41	00-749417	Wash Arm – Upper (LH)	1
42	00-436947-00001	Hanger	4
43	SC-041-50	Cap Screw $\frac{1}{4}$ -20 x $\frac{1}{2}$ Hex Hd.	8
44	WL-006-17	Lockwasher $\frac{1}{4}$ Medium	8
45	00-475087	Plug – Wash Arm (Used With Items 22, 23, 46, & 47)	12
*46	00-436945	Wash Arm – Upper (RH) (Shown)	1
*47	00-436946	Wash Arm – Upper (LH)	1

*Obsolete part number. For replacement, use 35, 36, 40, or 41 with Items 38 & 39.

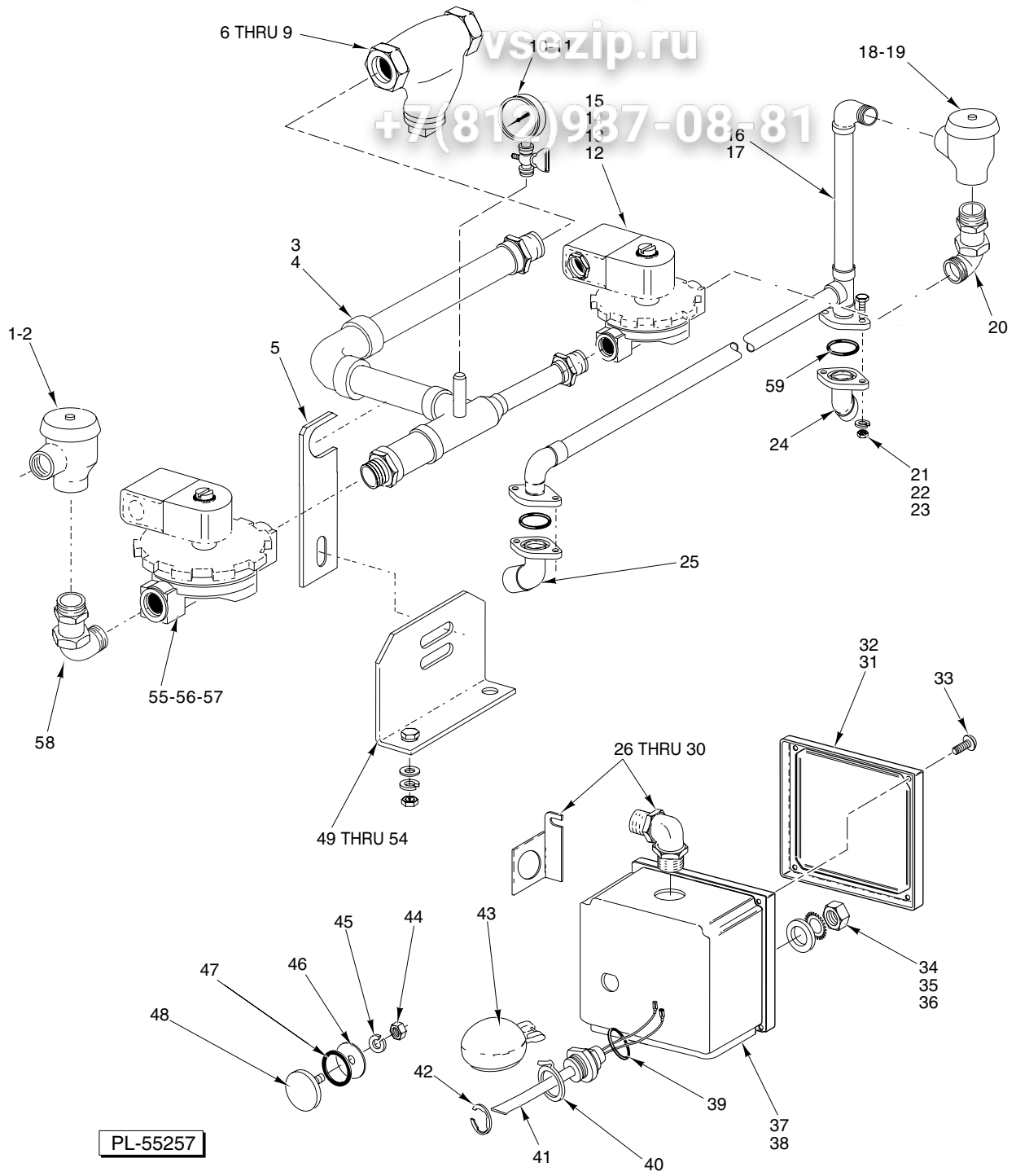

FILL & OUTSIDE RINSE PIPING

ILLUS.	PART	NAME OF PART	AMT.
PL-55257			
1	00-277112	Vacuum Breaker	1
2	00-118270	Service Kit – Vacuum Breaker	1
3	00-812956-00002	Piping Sub-Assy. (R-L)	1
4	00-812956-00001	Piping Sub-Assy. (L-R)	1

FILL & OUTSIDE RINSE PIPING

+7(812) 987 08-81

ILLUS.	PART	NAME OF PART	AMT.
5	00-435967	Plate – Fill Piping	1
6	00-186922	Line Strainer (Incls. Items 8, 9, & 10)	1
7	00-186923	Plug – Branch	1
8	00-186924	Gasket – Branch Plug	1
9	00-186925	Screen – Line Strainer	1
10	00-328247	Pressure Gauge – Water	1
11	00-436319	Petcock 1/4	1
12	00-435968-00001	Solenoid Valve 1/2 (115 V.) (Incls. Item 13)	1
13	00-271839-00001	Coil – Solenoid Valve	1
14	FE-024-57	Connector Straight (Non Metallic) “Sealtite”	2
		(1/2 Male Thd. x 1/2 Flex. Cnd.)	
15	FE-024-61	Connector 45 Deg. (Non Metallic) “Sealtite”	2
		(1/2 Male Thd. x 1/2 Flex. Cnd.)	
16	00-329831-00002	Fill Piping – Outside (R-L)	1
17	00-329831-00001	Fill Piping – Outside (L-R)	1
18	00-292909-00002	Vacuum Breaker 1/2	1
19	00-292910	Vacuum Breaker Float & Seal Assy.	1
20	00-329829	Adapter & Elbow Weldment 1/2	1
21	SC-041-15	Cap Screw 5/16-18 x 1 1/4 Hex Hd.	4
22	WL-006-23	Lockwasher 5/16 Medium (SST)	4
23	NS-015-11	Nut 5/16-18 Hex	4
24	00-435972-00002	Piping – Inside (RH)	1
25	00-435972-00001	Piping – Inside (LH)	1
*26	WL-013-16	Lockwasher 5/16 Internal Shakeproof	1
*27	00-436718	Ground Strap	1
*28	FE-006-37	Elbow 90 Deg. Short (1/2 Male Thd. x 1/2 Thinwall)	2
*29	FE-008-10	1/2 Gasket Assy.	2
*30	FE-006-07	Lock Nut 1/2 (Cnd.)	2
*31	00-112007	Gasket	1
*32	00-288465	Lid & Gasket Assy. (Incls. Item 58)	1
*33	SD-012-20	Self-Tapping Screw 8-32 x 1/2 Phil. Truss Hd., Type T	4
*34	NS-018-28	Jam Nut 1/2-20 Hex Fin	1
*35	WL-014-31	Lockwasher 1/2 External Shakeproof (SST)	1
*36	WS-010-40	Washer – Thrust	1
*37	00-270926	Junction Box – Auto Fill (RH) (R-L)	1
*38	00-436026	Junction Box – Auto Fill (LH) (L-R)	1
*39	00-067500-00072	“O” Ring	1
*40	00-112467	Retainer – Float	1
*41	00-271622	Probe & Switch Assy. (2 Wire) (Water Level)	1
*42	RR-010-13	Retaining Ring	1
*43	00-122674	Float Assy.	1
44	NS-015-01	Nut 1/4-20 Hex (SST)	AR
45	WL-006-17	Lockwasher 1/4 Medium	AR
46	WS-003-47	Washer	AR
47	00-067500-00031	“O” Ring	AR
48	00-119244	Cap & Stud Assy.	AR
49	00-435974	Bracket – Fill Piping	1
50	SC-041-12	Cap Screw 5/16-18 x 7/8 Hex Hd.	2
51	SC-041-11	Cap Screw 5/16-18 x 3/4 Hex Hd. (SST)	2
52	WS-029-05	Washer	6
53	WL-006-23	Lockwasher 5/16 Medium (SST)	4
54	NS-015-11	Nut 5/16-18 Hex	4
55	00-271002-01	Solenoid Valve 3/4 (115 V.) (Incls. Items 56 & 57)	1
56	00-271838	Service Kit – Solenoid Valve	1
57	00-271839-01	Coil – Solenoid Valve	1
58	00-328764	Adapter & Elbow Weldment	1
59	00-067500-00012	“O” Ring	4
*	00-065890-00085	Line – Splice	2

*C64A Machines

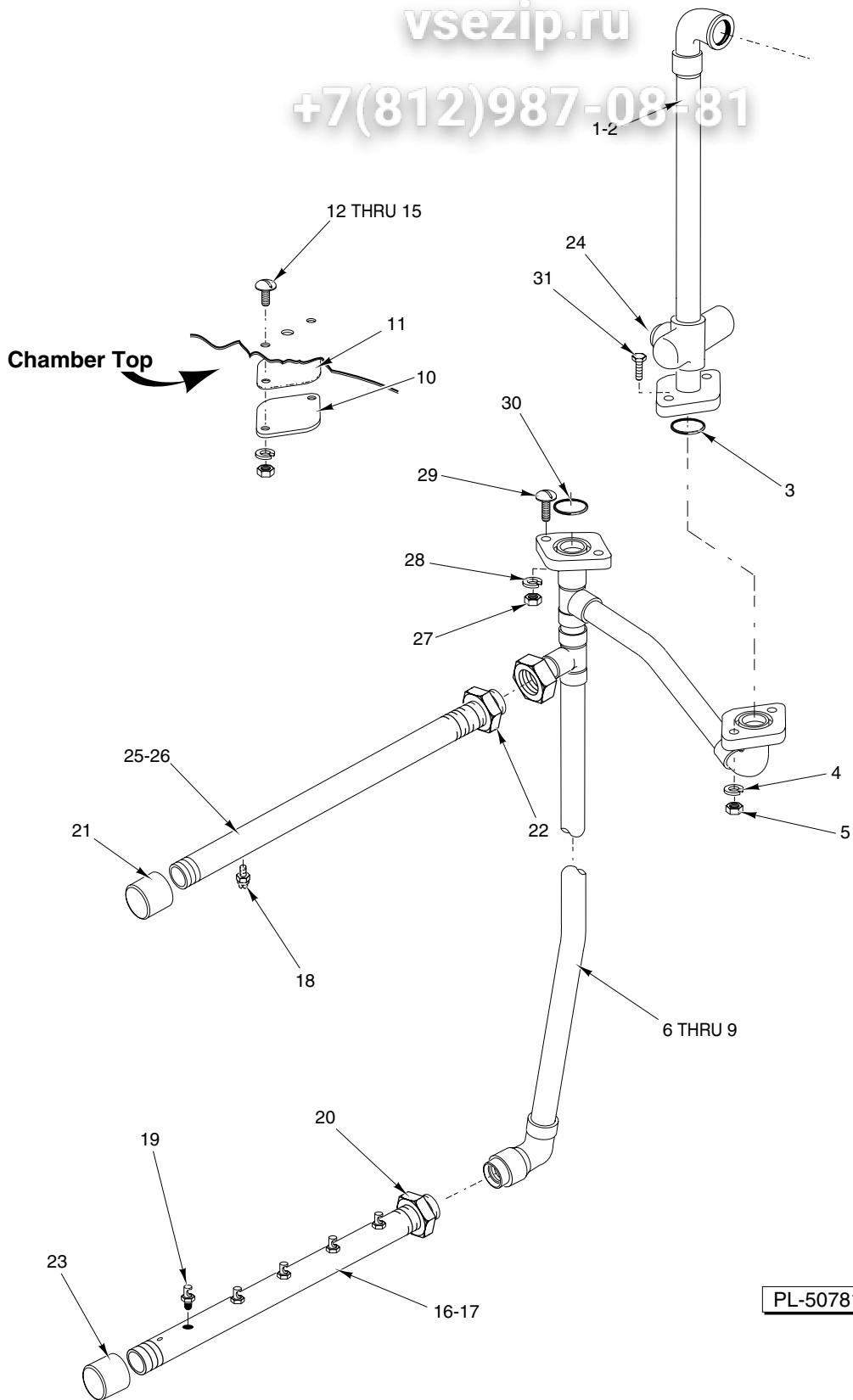

INSIDE METALLIC RINSE PIPING

vsezip.ru

+7(812)987-08-81

INSIDE METALLIC RINSE PIPING

ILLUS. PL-50781	PART	NAME OF PART	AMT.
1	00-329610-00001	Final Rinse Outside Piping (R-L)	1
2	00-329610-00002	Final Rinse Outside Piping (L-R)	1
3	00-067500-00012	"O" Ring	2
4	WL-006-23	Lockwasher ⁵ / ₁₆ Medium (SST)	2
5	NS-015-11	Nut ⁵ / ₁₆ -18 Hex	2
6	00-435979-00001	Final Rinse Inside Piping (R-L) (26 ¹ / ₈ Door Height)	1
7	00-435979-00002	Final Rinse Inside Piping (L-R) (26 ¹ / ₈ Door Height)	1
8	00-437132-00001	Final Rinse Inside Piping (R-L) (32 ¹ / ₈ Door Height)	1
9	00-437132-00002	Final Rinse Inside Piping (L-R) (32 ¹ / ₈ Door Height)	1
10	00-122402-00002	Flange	1
11	00-276407	Gasket – Rinse Pipe	1
12	SC-053-16	Mach. Screw ⁵ / ₁₆ -18 x ⁵ / ₈ Truss Hd.	2
13	SC-053-15	Mach. Screw ⁵ / ₁₆ -18 x ¹ / ₂ Truss Hd. (SST)	2
14	WL-006-23	Lockwasher ⁵ / ₁₆ Medium (SST)	4
15	NS-015-11	Nut ⁵ / ₁₆ -18 Hex	4
16	00-271027-00001	Lower Rinse Arm (R-L) 5 Nozzles (Incls. Items 19, 20, & 23)	1
17	00-271027-00002	Lower Rinse Arm (L-R) 5 Nozzles (Incls. Items 19, 20, & 23)	1
18	00-081812	Nozzle – Rinse (Brass0) (0.078 Dia. Orifice)	6
19	00-022731-00003	Nozzle – Rinse (SST) #50 Drill (0.070)	5
20	FP-030-27	Lock Nut ¹ / ₂ NPSL Pipe (Brass)	1
21	FP-029-08	Pipe Cap ¹ / ₂ (Brass)	1
22	FP-030-27	Lock Nut ¹ / ₂ NPSL Pipe (Brass)	1
23	FP-029-08	Pipe Cap ¹ / ₂ (Brass)	1
24	FP-028-03	Pipe Plug ¹ / ₈ Sq. Hd. (Brass)	1
25	00-271088-00001	Upper Rinse Arm (R-L) 6 Nozzles (Incls. Items 18, 21, & 22)	1
26	00-271088-00002	Upper Rinse Arm (L-R) 6 Nozzles (Incls. Items 18, 21, & 22)	1
27	NS-015-11	Nut ⁵ / ₁₆ -18 Hex	2
28	WL-006-23	Lockwasher ⁵ / ₁₆ Medium (SST)	2
29	SC-053-18	Mach. Screw ⁵ / ₁₆ -18 x ⁷ / ₈ Truss Hd. (SST)	2
30	00-067500-00012	"O" Ring	1
31	SC-041-15	Cap Screw ⁵ / ₁₆ -18 x 1 ¹ / ₄ Hex Hd.	2

vsezip.ru

+7(812)987-08-81

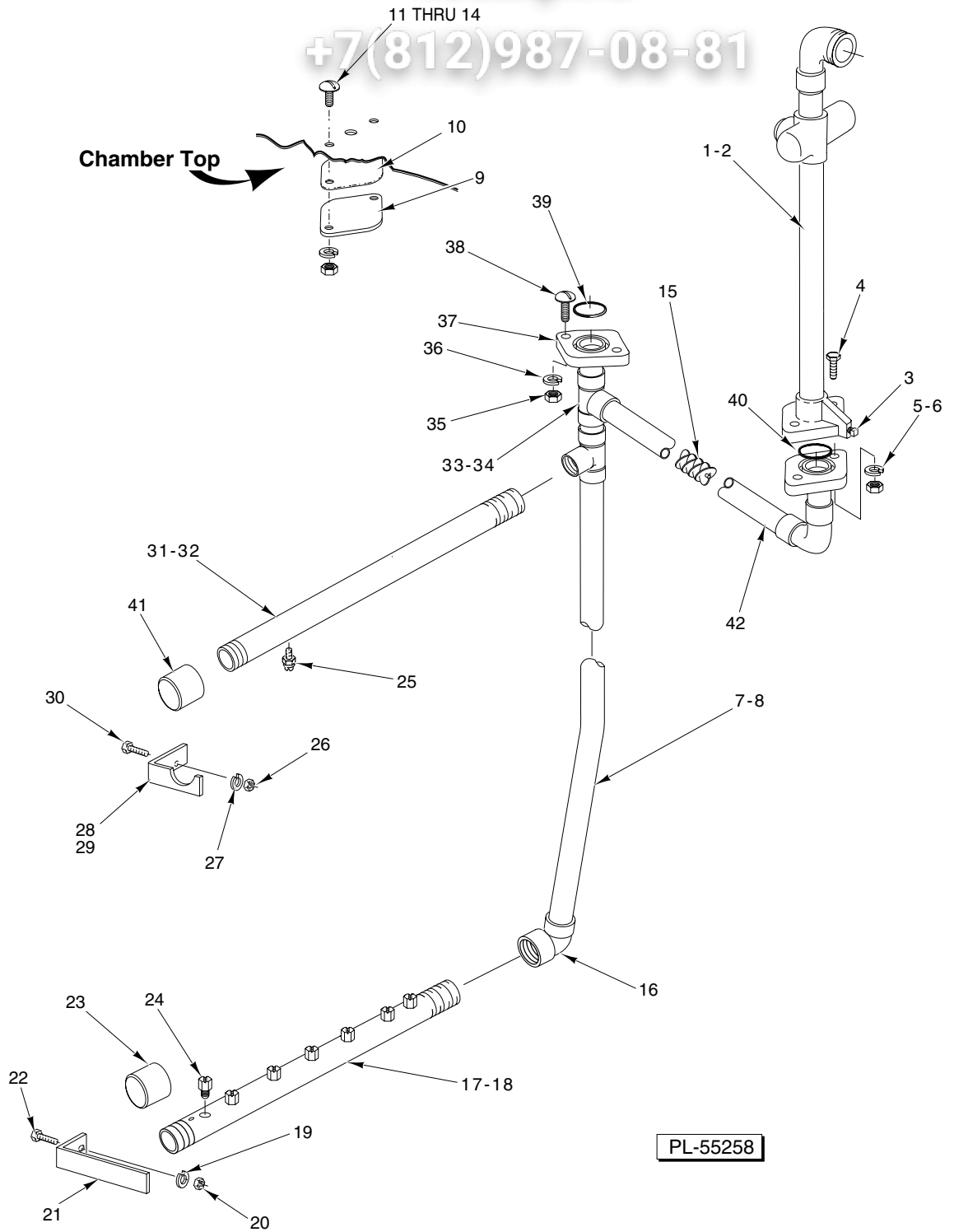

**INSIDE RINSE PIPING
(NON METALLIC)**

vsezip.ru

+7(812)987-08-81
**INSIDE RINSE PIPING
 (NON METALLIC)**

ILLUS.	PART	NAME OF PART	AMT.
	PL-55258		
1	00-329608-00001	Final Outside Rinse Piping (R-L)	1
2	00-329608-00002	Final Outside Rinse Piping (L-R)	1
3	FP-028-03	Pipe Plug 1/8 Sq. Hd. (Brass)	2
4	SC-041-15	Cap Screw 5/16-18 x 1 1/2 Hex Hd.	2
5	WL-006-23	Lockwasher 5/16 Medium (SST)	2
6	NS-015-11	Nut 5/16-18 Hex	2
7	00-274708	Tube – Inside Rinse (32 1/8 Door Height)	1
8	00-274536	Tube – Inside Rinse (26 1/8 Door Height)	1
9	00-122402-00002	Flange	1
10	00-276407	Gasket – Rinse Pipe	1
11	SC-053-16	Mach. Screw 5/16-18 x 5/8 Truss Hd.	2
12	SC-053-15	Mach. Screw 5/16-18 x 1/2 Truss Hd. (SST)	2
13	WL-006-23	Lockwasher 5/16 Medium (SST)	4
14	NS-015-11	Nut 5/16-18 Hex	4
15	00-435070	Mixer – Spiral	1
16	00-185781	Elbow – 1/2 x 90 Deg. (P.V.C.)	2
17	00-476504-00001	Lower Rinse Arm (R-L) 7 Nozzles (Incls. Items 23 & 24)	1
18	00-476504-00002	Lower Rinse Arm (L-R) 7 Nozzles (Incls. Items 23 & 24)	1
19	WL-006-16	Lockwasher 1/4 Light	2
20	NS-015-01	Nut 1/4-20 Hex (SST)	2
21	00-274570	Bracket	1
22	SC-128-05	Mach. Screw 1/4-20 x 1/2 Fil. Hd. (SST)	2
23	00-276380-00002	Cap – Lower Rinse Arm	1
24	00-476369	Nozzle – Rinse (SST) #50 Drill (0.070)	7
25	00-081812-00002	Nozzle – Rinse (SST) (0.078 Dia. Orifice)	6
26	NS-015-01	Nut 1/4-20 Hex (SST)	2
27	WL-006-16	Lockwasher 1/4 Light	2
28	00-274532-00001	Bracket (R-L)	1
29	00-274532-00002	Bracket (L-R)	1
30	SC-024-06	Mach. Screw 1/4-20 x 1/2 Fil. Hd. (SST)	2
31	00-274535-00001	Upper Rinse Arm (R-L) 6 Nozzles (Incls. Items 25 & 41)	1
32	00-274535-00002	Upper Rinse Arm (L-R) 6 Nozzles (Incls. Items 25 & 41)	1
33	FP-085-51	Tee 1/2 x 1/2 x 1/2 NPT Schedule 80 PVC	2
34	00-274531-00002	Tube (1 1/4 Lg.)	1
35	NS-015-11	Nut 5/16-18 Hex	2
36	WL-006-23	Lockwasher 5/16 Medium (SST)	2
37	00-274533	Flange	2
38	SC-053-18	Mach. Screw 5/16-18 x 7/8 Truss Hd. (SST)	2
39	00-067500-00012	“O” Ring	1
40	00-067500-00012	“O” Ring	2
41	00-276380-00002	Cap – Upper Rinse Arm	1
42	00-274531-00003	Tube – Inside Rinse 15 1/8 Lg.	1

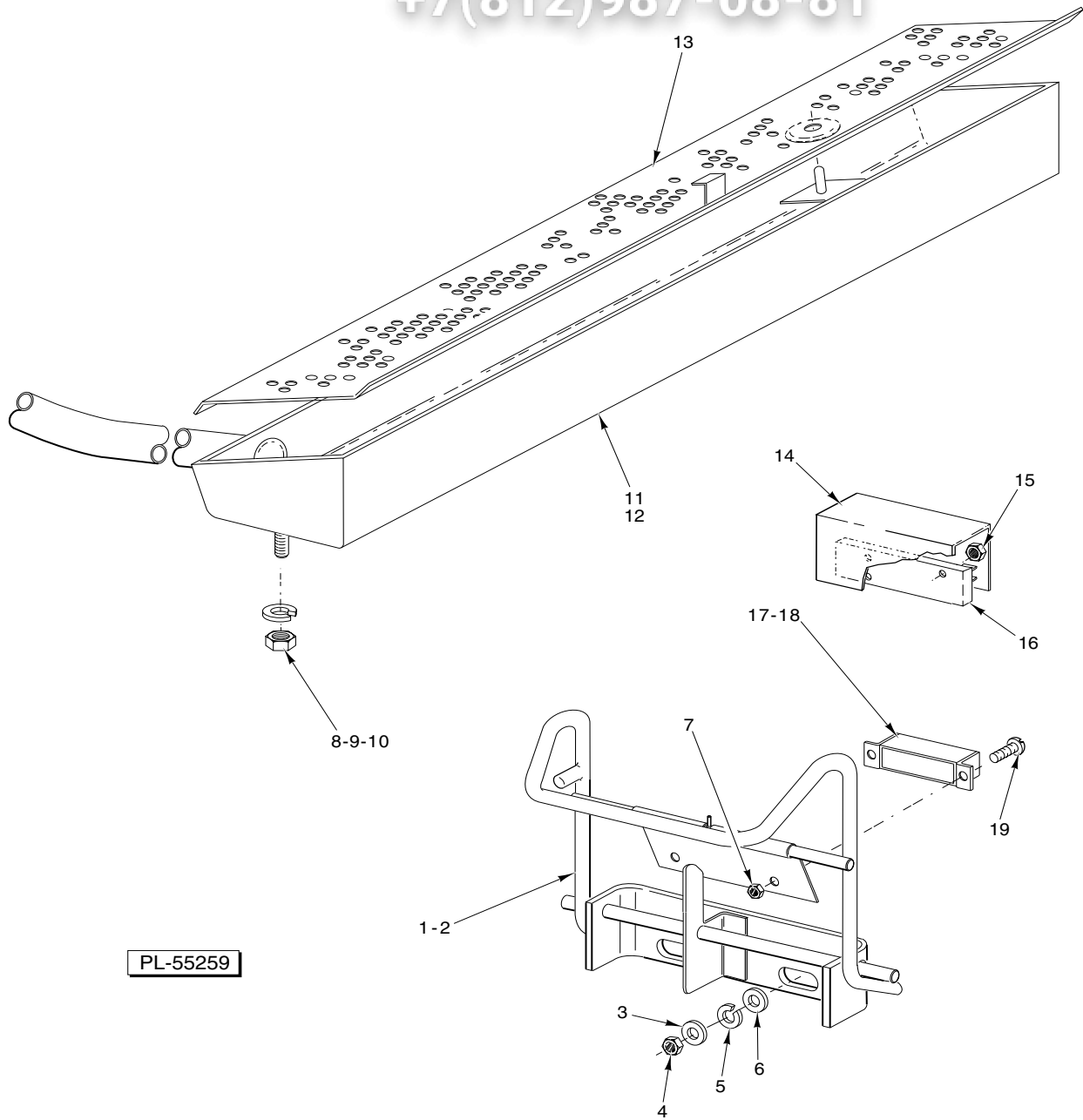

ACTUATOR MECHANISM & RINSE DRAIN OFF PAN

vsezip.ru

+7(812)987-08-81

ACTUATOR MECHANISM & RINSE DRAIN OFF PAN

ILLUS.	PART	NAME OF PART	AMT.
PL-55259			
1	00-436027	Actuator (L-R).....	1
2	00-436955	Actuator (R-L).....	1
3	WS-029-05	Washer	2
4	NS-036-19	Stop Nut 5/16-18.....	2
5	WL-006-23	Lockwasher 5/16 Medium (SST).....	2
6	WS-017-08	Washer	2
7	NS-031-50	Stop Nut 6-32 Hex (SST).....	2
8	WS-003-49	Washer	2
9	WL-006-17	Lockwasher 1/4 Medium.....	2
10	NS-015-01	Nut 1/4 Hex (SST).....	2
11	00-329579-00005	Rinse Pan Assy. (L-R).....	1
12	00-329579-00006	Rinse Pan Assy. (R-L).....	1
13	00-812922-00001	Strainer	1
14	00-270996	Insulator – Switch.....	1
15	NS-031-50	Stop Nut 6-32 Hex (SST).....	2
16	00-749347	Switch – Reed Encapsulated.....	1
17	00-290160	Magnet (Dot Not Visible).....	1
18	00-290159	Retainer – Magnet.....	1
19	SC-127-26	Mach. Screw 6-32 x 3/8 Rd. Hd. (SST).....	2

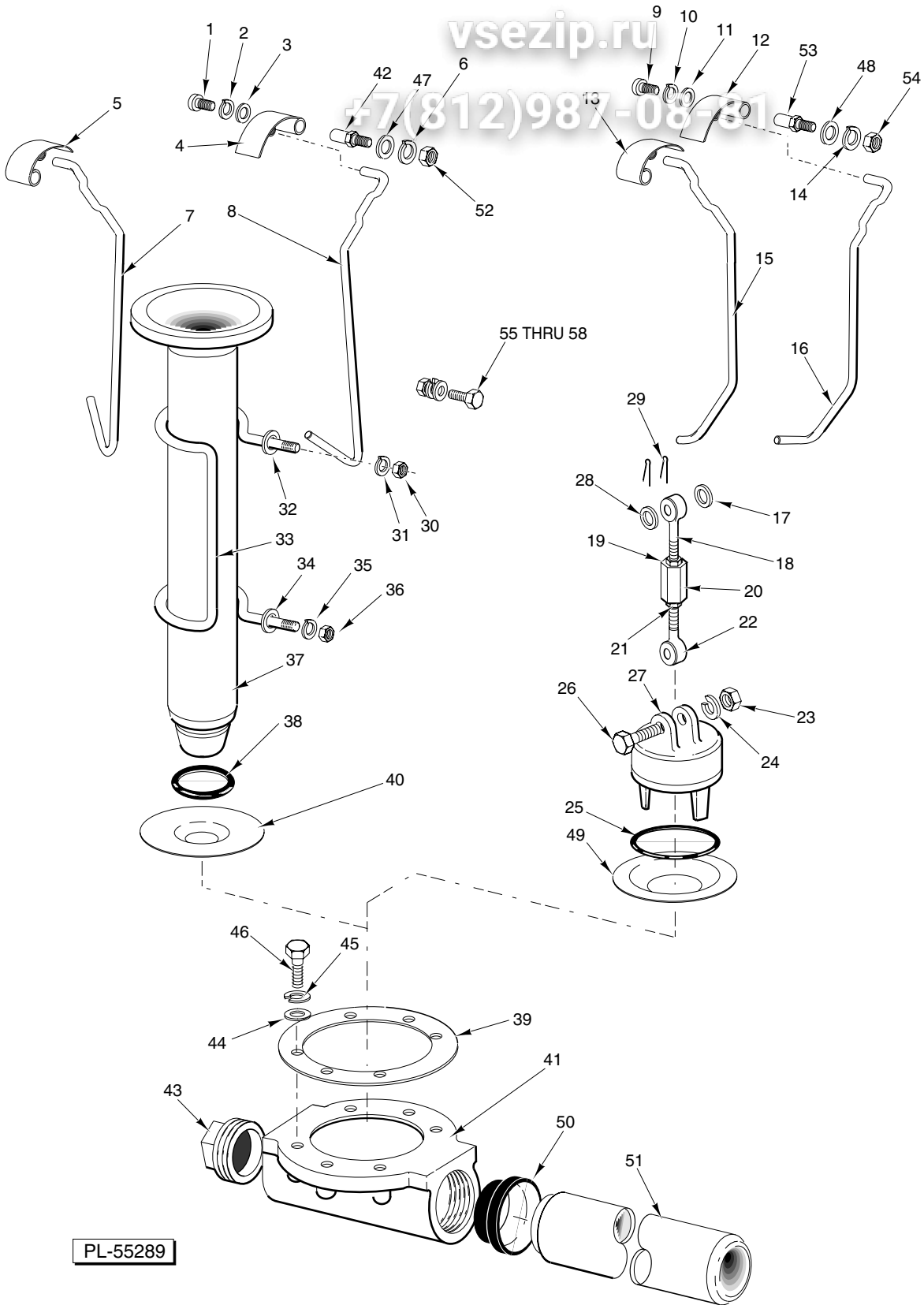

**DRAIN UNIT
(WASH/RINSE SECTION)**

**DRAIN UNIT
(WASH/RINSE SECTION)**

ILLUS. PL-55289	PART	NAME OF PART	AMT.
1	SC-021-22	Mach. Screw 10-24 x 3/8 Rd. Hd. (SST)	2
2	WL-006-07	Lockwasher #10 Medium	2
3	WS-023-34	Washer	2
4	00-271070	Drain Lever (RH)	1
5	00-274096	Drain Lever (LH)	1
6	WL-006-17	Lockwasher 1/4 Medium	2
7	00-436953	Lift Rod Overflow (LH)	1
8	00-436954	Lift Rod Overflow (RH)	1
*9	SC-021-22	Mach. Screw 10-24 x 3/8 Rd. Hd. (SST)	2
*10	WL-006-07	Lockwasher #10 Medium	2
*11	WS-023-34	Washer	2
*12	00-271070	Drain Lever (RH)	1
*13	00-274096	Drain Lever (LH)	1
*14	WL-006-17	Lockwasher 1/4 Medium	2
*15	00-436961	Lift Rod – Drain (LH)	1
*16	00-436962	Lift Rod – Drain (RH)	1
*17	WS-017-08	Washer	2
*18	00-065958	Pull Rod	2
*19	NS-018-06	Jam Nut 5/16-18 Hex Fin	2
*20	00-016269	Nut – Pull Rod Adjustor	2
*21	NS-018-06	Jam Nut 5/16-18 Hex Fin	2
*22	00-065958	Pull Rod	2
*23	NS-015-11	Nut 5/16-18 Hex	2
*24	WL-006-23	Lockwasher 5/16 Medium (SST)	2
*25	00-067500-00118	“O” Ring	2
*26	SC-041-17	Cap Screw 5/16-18 x 1 1/2 Hex Hd. (SST)	2
*27	00-077466	Plug – Drain	2
*28	WS-017-08	Washer	2
*29	PC-005-02	Cotter Pin 1/16 x 1/2 (SST)	4
30	NS-015-11	Nut 5/16-18 Hex	4
31	WL-006-23	Lockwasher 5/16 Medium (SST)	2
32	WS-017-01	Washer	4
33	00-270952-00002	Retainer	2
34	WS-017-01	Washer	4
35	WL-006-23	Lockwasher 5/16 Medium (SST)	2
36	NS-015-11	Nut 5/16-18 Hex	4
37	00-119099-00002	Tube – Overflow	2
38	00-067500-00120	“O” Ring	2
39	00-289464	Gasket – Drain	2
40	00-270947	Sleeve – Drain Body	2
41	00-289465	Drain Body	2
42	00-119116	Axle – Drain Lever	2
43	FP-028-32	Pipe Plug 2 Sq. Hd.	1
44	WS-006-44	Washer	12
45	WL-006-28	Lockwasher 3/8 Medium	12
46	SC-041-30	Cap Screw 3/8-16 x 1 Hex Hd. (SST)	12
47	WS-022-01	Washer	2
*48	WS-022-01	Washer	2
*49	00-106283	Sleeve – Drain Valve Body	1
50	00-328813	Bushing – Drain	2
51	00-274132-00005	Drain Pipe – Wash/Rinse Section	1
52	NS-015-01	Nut 1/4-20 Hex (SST)	2
*53	00-119116	Axle – Drain Lever	2
*54	NS-015-01	Nut 1/4-20 Hex (SST)	2
55	SC-041-11	Cap Screw 5/16-18 x 3/4 Hex Hd. (SST)	AR
56	WS-017-01	Washer	AR
57	WL-006-23	Lockwasher 5/16 Medium (SST)	AR
58	NS-015-11	Nut 5/16-18 Hex	AR

*Use in wash/rinse tank on machines with RS or PW.

vsezip.ru

+7(812)987-08-81

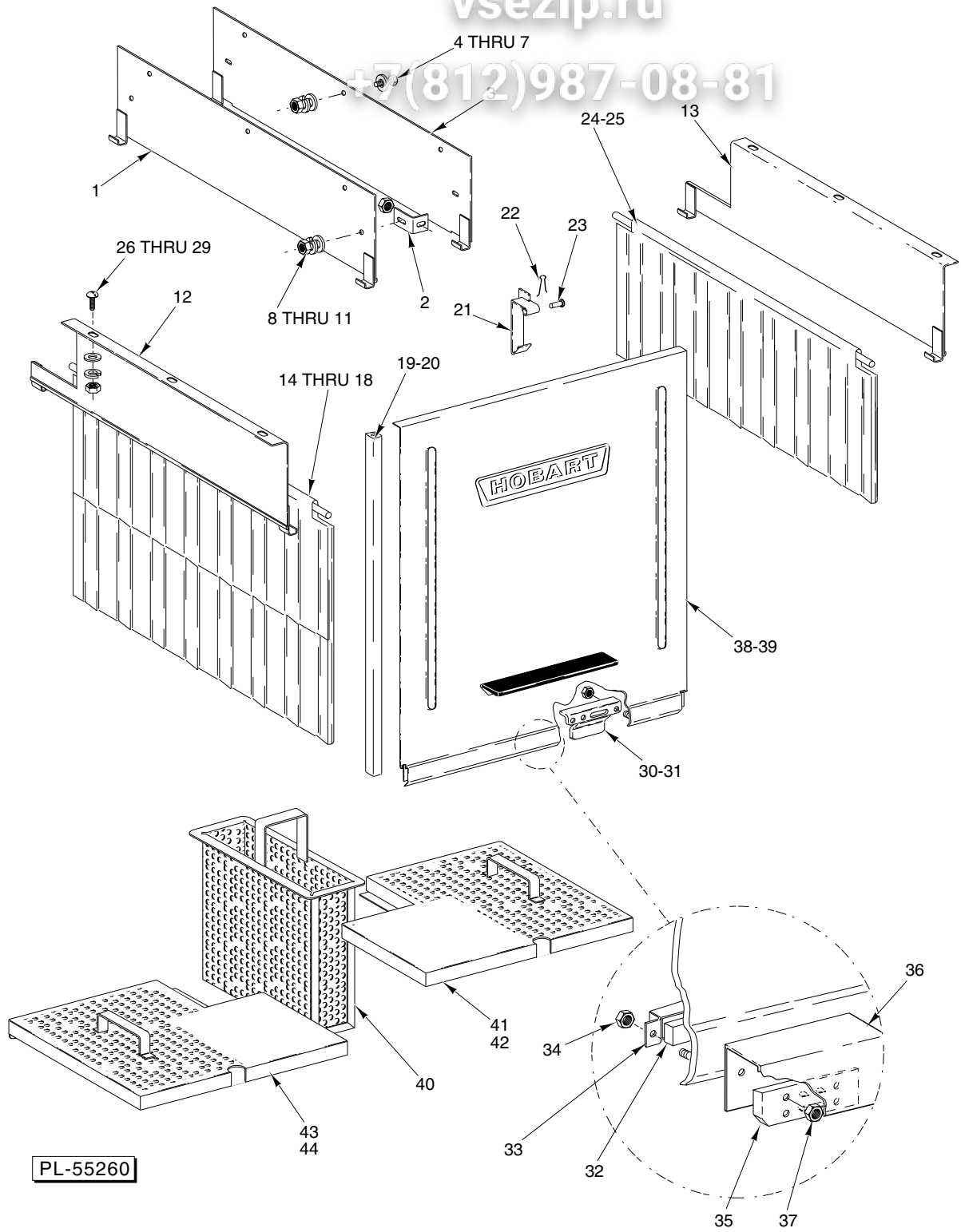

DOORS, CURTAINS, BAFFLES, & STRAINERS

vsezip.ru

DOORS, CURTAINS, BAFFLES, &

+7(812)987-08-81

ILLUS.	PART	NAME OF PART	AMT.
PL-55260			
1	00-435963-00001	Baffle – Center	1
2	00-289828	Bracket	2
3	00-435962-00001	Baffle – Center	1
4	SC-041-05	Cap Screw 1/4-20 x 5/8 Hex Hd.	10
5	WS-003-49	Washer	13
6	WL-006-17	Lockwasher 1/4 Medium	11
7	NS-015-01	Nut 1/4-20 Hex (SST)	11
8	SC-041-05	Mach. Screw 1/4-20 x 5/8 Hex Hd. (SST)	2
9	WS-022-01	Washer	2
10	WL-006-17	Lockwasher 1/4 Medium	2
11	NS-015-01	Nut 1/4-20 Hex (SST)	2
12	00-436959-00001	Baffle – Final Rinse (R-L)	1
13	00-435982-00001	Baffle – Final Rinse (L-R)	1
14	00-271084	Splash Curtain (26 1/8 Door Height)	4
15	00-271084-00002	Splash Curtain (32 1/8 Door Height)	4
16	00-120266-00001	Curtain Rod	4
17	00-120152-00055	Splash Curtain Assy. (Incls. Items 14 & 16) (26 1/8 Door Height)	AR
18	00-120152-00056	Splash Curtain Assy. (Incls. Items 15 & 16) (32 1/8 Door Height)	AR
19	00-112378-00049	Door Slide (26 1/8 Door Height)	4
20	00-112378-00050	Door Slide (32 1/8 Door Height)	4
21	00-185864	Catch – Door	2
22	PC-005-02	Cotter Pin 1/16 x 1/2 (SST)	2
23	00-012114	Pin	2
24	00-120151-00001	Splash Curtain (10-C1)	1
25	00-120266-00001	Curtain Rod	1
26	SC-053-42	Mach. Screw 1/4-20 x 5/8 Truss Hd. (SST)	6
27	WS-022-01	Washer	6
28	WL-006-17	Lockwasher 1/4 Medium	6
29	NS-015-01	Nut 1/4-20 Hex (SST)	6
30	00-328065	Actuator – Lift Drain	2
31	NS-031-21	Stop Nut – Special 1/4-20 Hex	4
32	00-290160	Magnet	2
33	00-290159	Retainer – Magnet	2
34	NS-031-50	Stop Nut 6-32 Hex (SST)	4
35	00-749347	Reed Mounting Board Assy.	2
36	00-270996	Insulator – Switch	2
37	NS-031-50	Stop Nut 6-32 Hex (SST)	4
38	00-328064-00007	Door (26 1/8)	1
39	00-328079-00007	Door (32 1/8)	1
40	00-271100	Bucket – Strainer	2
41	00-435941	Strainer – Front (RH)	1
42	00-436034	Strainer – Rear (RH) (Not Shown)	1
43	00-435943	Strainer – Front (LH)	1
44	00-435939	Strainer – Rear (LH) (Not Shown)	1

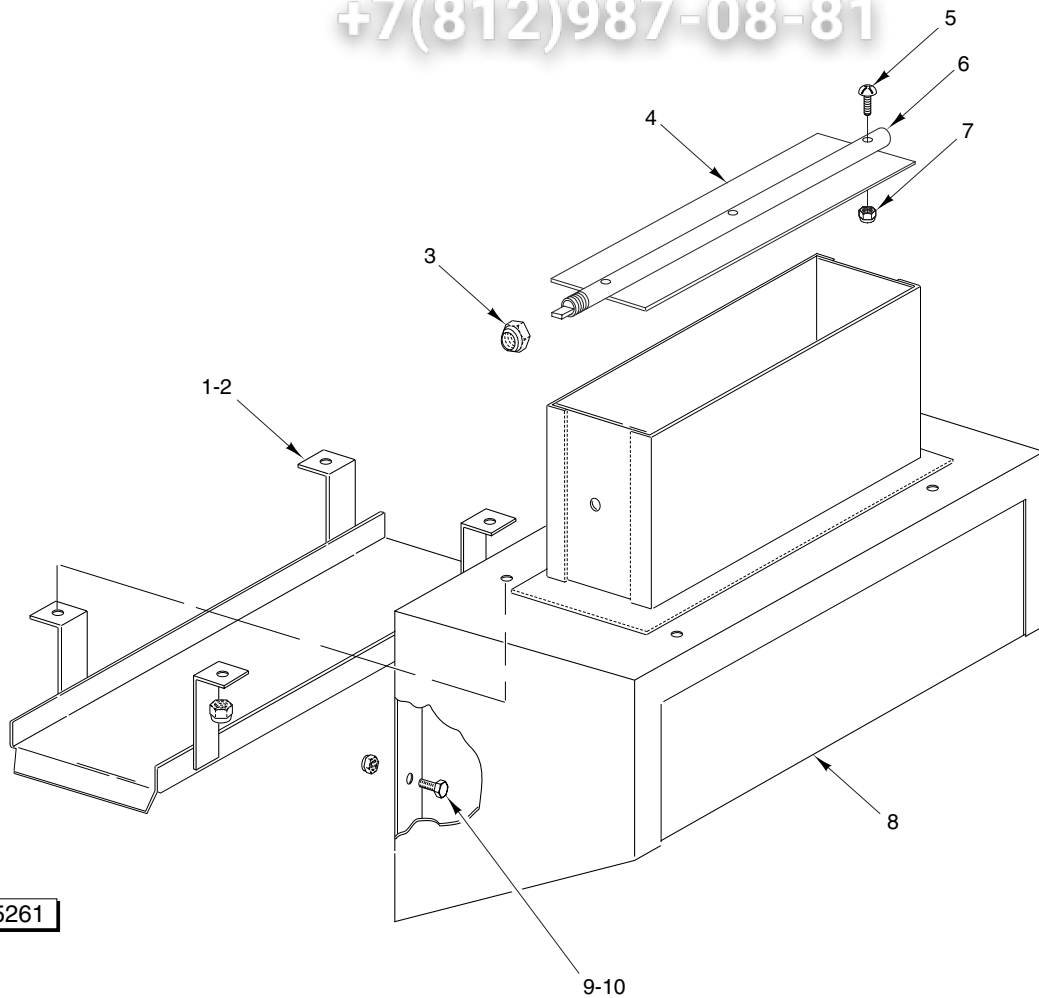

VENT HOOD

ILLUS. NO.	PART NO.	NAME OF PART	AMT.
1	00-435799	Drip Shield Assy.	1
2	NS-031-15	Stop Nut 10-24 Hex (SST)	4
3	NS-036-12	Stop Nut 3/8-24 "Elastic"	1
4	00-075623	Damper – Vent Stack	1
5	SC-125-25	Mach. Screw 6-32 x 3/4 Rd. Hd. (SST)	3
6	00-064919	Shaft – Damper	1
7	NS-031-50	Stop Nut 6-32 Hex (SST)	3
8	435794-00001	Vent Hood Assy. (Incls. Items 1 thru 7)	1
9	SC-041-05	Cap Screw 1/4-20 x 5/8 Hex Hd.	11
10	NS-031-19	Stop Nut 1/4-20 "Elastic" (SST)	11

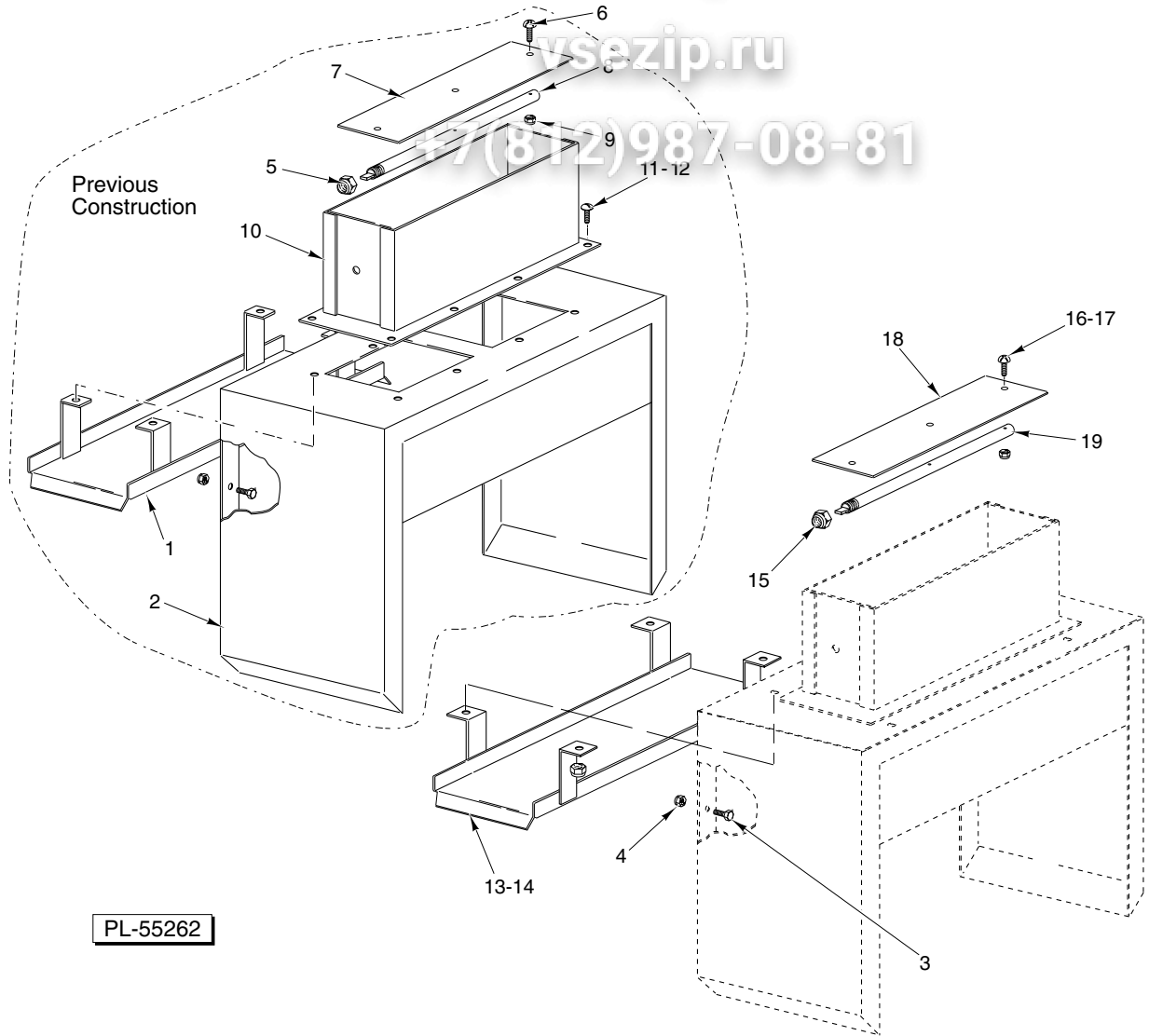

PL-55262

EXTENDED HOOD

ILLUS. NO.	PART NO.	NAME OF PART	AMT.
1	00-080553	Drip Shield Assy.	1
2	00-079463-00002	Extended Hood Assy.	1
3	SC-041-05	Cap Screw 1/4-20 x 5/8 Hex Hd.	13
4	NS-031-19	Stop Nut 1/4-20 "Elastic" (SST)	13
5	NS-036-12	Stop Nut 3/8-24 "Elastic"	1
6	SC-125-25	Mach. Screw 6-32 x 3/4 Rd. Hd. (SST)	3
7	00-075623	Damper – Vent Stack	1
8	00-064919	Shaft – Damper	1
9	NS-031-50	Stop Nut 6-32 Hex (SST)	3
10	00-075621	Vent Stack Assy.	1
11	SC-053-02	Mach. Screw 10-24 x 1/2 Truss Hd. (SST)	8
12	NS-031-15	Stop Nut 10-24 "Elastic" (SST)	8
13	00-435799	Drip Shield Assy.	1
14	NS-031-15	Stop Nut 10-24 Hex (SST)	4
15	NS-036-12	Stop Nut 3/8-24 "Elastic"	1
16	SC-125-25	Mach. Screw 6-32 x 3/4 Rd. Hd. (SST)	3
17	NS-031-50	Stop Nut 6-32 Hex (SST)	3
18	00-075623	Damper – Vent Stack	1
19	00-064919	Shaft – Damper	1

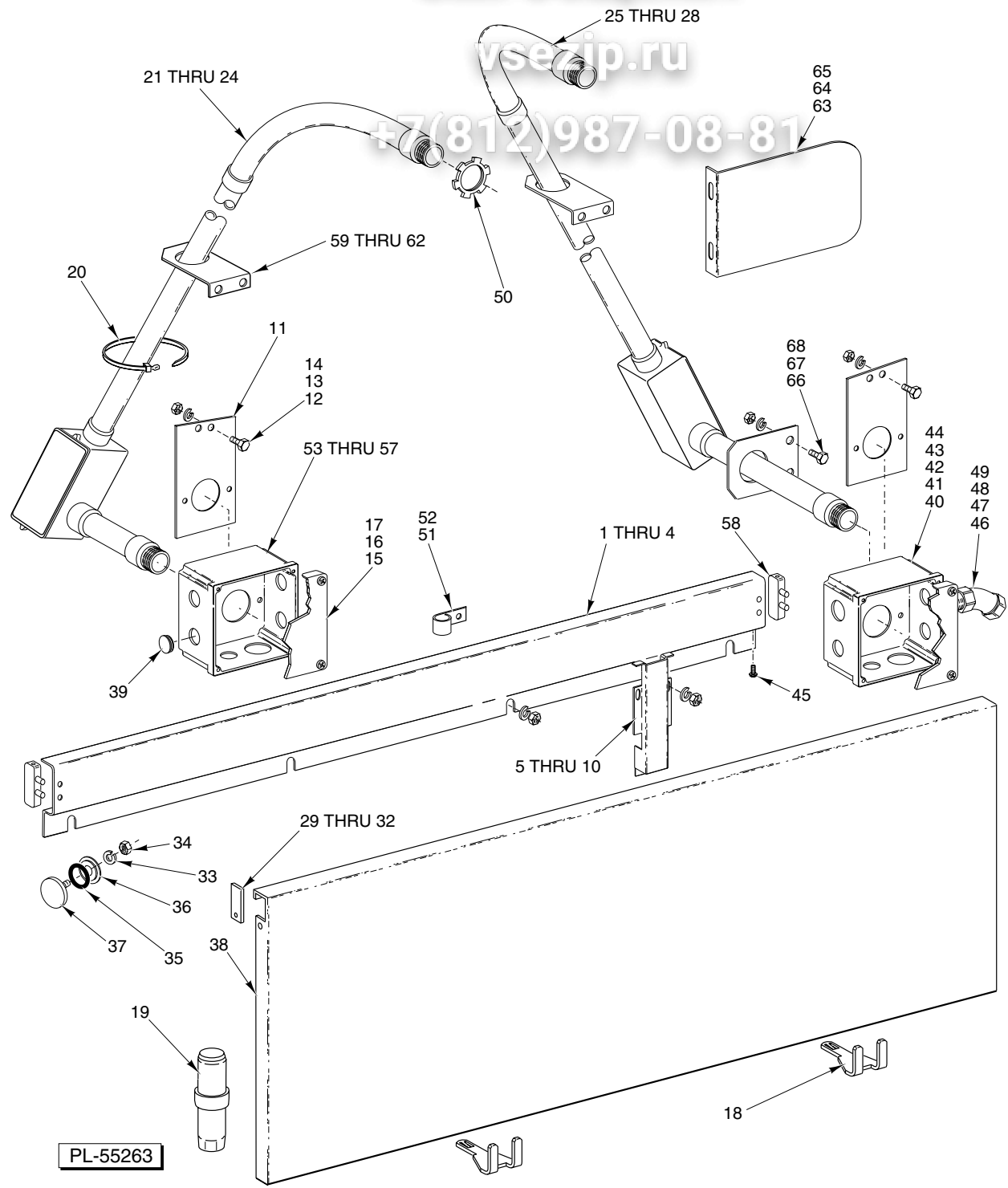

**MISCELLANEOUS
(WASH/RINSE SECTION)**

ILLUS.	PART	NAME OF PART	AMT.
1	00-436032	Wireway – Horizontal	1
2	WS-017-06	Washer	4
3	WL-006-17	Lockwasher 1/4 Medium	4
4	NS-015-01	Nut 1/4-20 Hex (SST)	4
5	00-271055	Wireway – Vertical	1

MISCELLANEOUS (WASH/RINSE SECTION)

+7(812)987-08-81

ILLUS. PL-55263	PART	NAME OF PART	AMT.
6	SC-021-22	Mach. Screw 10-24 x 3/8 Rd. Hd. (SST)	1
7	WL-006-07	Lockwasher #10 Medium	1
8	WS-017-06	Washer	2
9	WL-006-17	Lockwasher 1/4 Medium	2
10	NS-015-01	Nut 1/4-20 Hex (SST)	2
11	00-436024	Plate – Junction Box Support	2
12	SC-041-11	Cap Screw 5/16-18 x 3/4 Hex Hd. (SST)	4
13	WL-006-23	Lockwasher 5/16 Medium (SST)	4
14	NS-015-11	Nut 5/16-18 Hex	4
15	00-288465	Lid & Gasket Assy. (Incls. Item 16)	2
16	00-112007	Gasket	2
17	SD-012-20	Self-Tapping Screw 8-32 x 1/2 Phil. Truss Hd., Type T	8
18	00-271061	Support	2
19	00-288946-00002	Foot – Adjustable	4
20	00-122577-00002	Wire Tie	6
21	00-436941	Conduit – P.V.C. (26 1/8 Door Height) (LH) (Electric and Steam Heat)	1
22	00-437131	Conduit – P.V.C. (32 1/8 Door Height) (LH) (Electric and Steam Heat)	1
23	00-328470-00001	Conduit – P.V.C. (26 1/8 Door Height) (LH) (Gas Heat)	1
24	00-328470-00002	Conduit – P.V.C. (32 1/8 Door Height) (LH) (Gas Heat)	1
25	00-436037	Conduit – P.V.C. (26 1/8 Door Height) (RH) (Electric and Steam Heat)	1
26	00-437130	Conduit – P.V.C. (32 1/8 Door Height) (RH) (Electric and Steam Heat)	1
27	00-328469-00001	Conduit – P.V.C. (26 1/8 Door Height) (RH) (Gas Heat)	1
28	00-328469-00002	Conduit – P.V.C. (32 1/8 Door Height) (RH) (Gas Heat)	1
29	00-436888	Cover – Panel Notch	2
30	SC-053-05	Mach. Screw 10-24 x 3/8 Truss Hd., Slotted	2
31	WS-019-06	Washer	2
32	NS-031-16	Stop Nut 10-24 “Elastic” (SST)	2
33	WL-006-17	Lockwasher 1/4 Medium	2
34	NS-015-01	Nut 1/4-20 Hex (SST)	2
35	00-067500-00031	“O” Ring	2
36	00-119254	Retainer – Cap	2
37	00-119244	Cap & Stud Assy.	2
38	00-436031	Panel – Front Trim	1
39	PB-004-08	Plug Button Heyco 2703	AR
40	00-270923-00004	Box – Junction (RH)	1
41	SC-041-05	Cap Screw 1/4-20 x 5/8 Hex Hd.	2
42	WS-003-49	Washer	2
43	WL-006-17	Lockwasher 1/4 Medium	2
44	NS-015-01	Nut 1/4-20 Hex (SST)	2
45	SD-007-38	Self-Tapping Screw 8 x 1/4 Phil. Bind Hd., Type B	2
46	FE-008-44	Connector 45 Deg. (3/4 Male Thd. x 3/4 Thinwall)	1
47	FE-008-11	Gasket – Electrical	1
48	FE-006-06	Lock Nut 3/4	1
49	FE-007-32	Connector – Conduit 3/4 TS	1
50	FE-009-07	Lock Nut 1 1/4	4
51	00-294677-00003	Clamp – Wire (3/4 I.D.)	AR
52	NS-047-94	Lock Nut Special 3/16	AR
53	00-270923-00005	Box – Junction (LH)	1
54	SC-041-05	Cap Screw 1/4-20 x 5/8 Hex Hd.	2
55	WS-003-49	Washer	2
56	WL-006-17	Lockwasher 1/4 Medium	2
57	NS-015-01	Nut 1/4-20 Hex (SST)	2
58	00-271057	Cap – Wireway	2
59	SC-041-50	Cap Screw 1/4-20 x 1/2 Hex Hd.	4
60	WS-022-01	Washer	4
61	WL-006-17	Lockwasher 1/4 Medium	4
62	NS-015-01	Nut 1/4-20 Hex (SST)	4
63	00-287625	Splash Shield	2
64	NS-031-15	Stop Nut 10-24 Hex (SST)	4
65	SC-053-02	Mach. Screw 10-24 x 1/2 Truss Hd. (SST)	4
66	SC-041-11	Cap Screw 5/16-18 x 3/4 Hex Hd. (SST)	2
67	WL-006-23	Lockwasher 5/16 Medium (SST)	2
68	NS-015-11	Nut 5/16-18 Hex	2

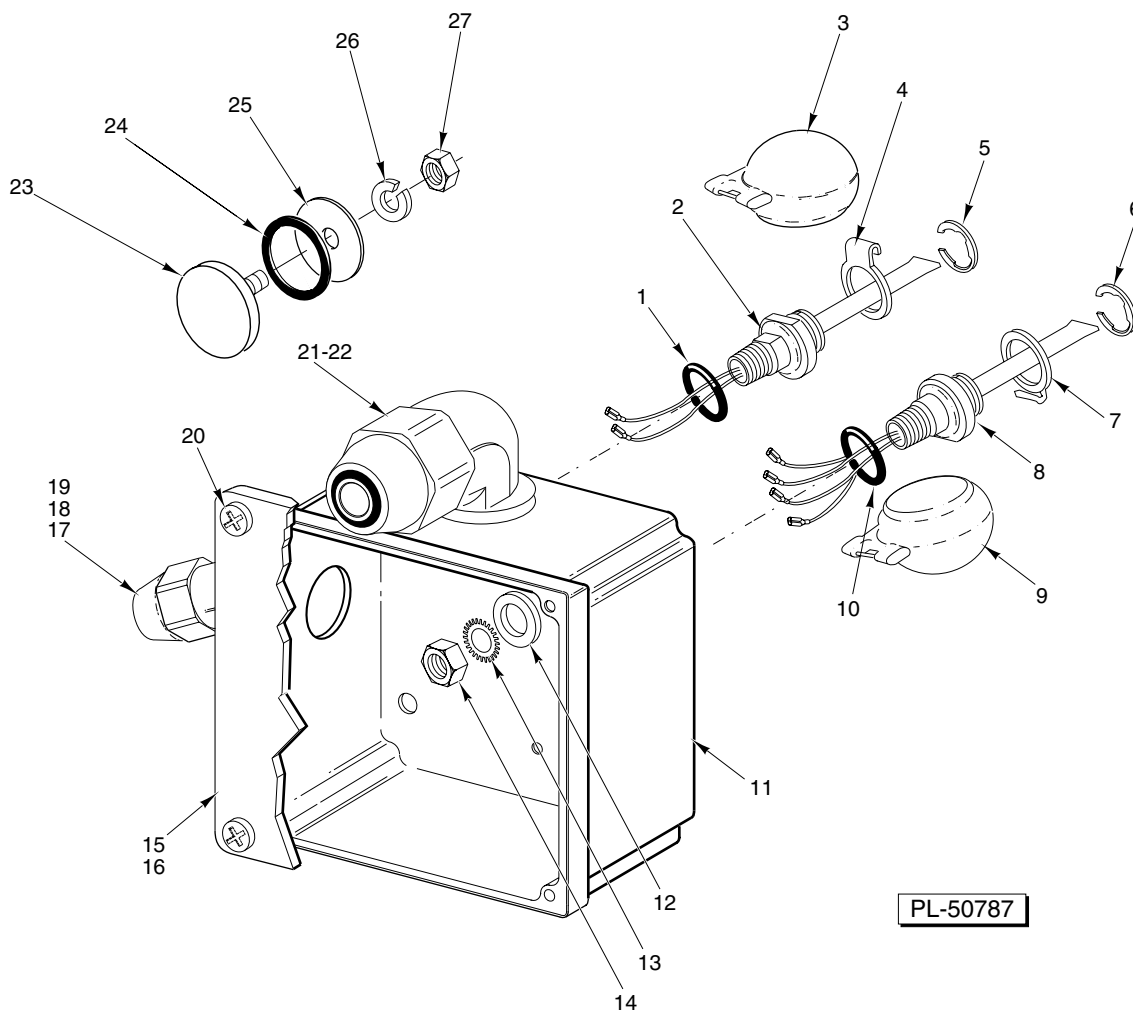

**LOW WATER PROTECTION
(STEAM HEAT/WASH & RINSE TANK)**

vsezip.ru

+7(812)987-08-81

**LOW WATER PROTECTION
(STEAM HEAT/WASH & RINSE TANK)**

ILLUS.	PART	NAME OF PART	AMT.
PL-50787			
1	00-067500-00072	"O" Ring	AR
2	00-271622	Probe & Switch Assy. (2 Wire) (Water Level)	AR
3	00-122674	Float Assy.	AR
4	00-112467	Retainer – Float	AR
5	RR-010-13	Retaining Ring	AR
6	RR-010-13	Retaining Ring	2
7	00-112467	Retainer – Float	2
8	00-271621	Probe & Switch Assy. (4 Wire) (Temperature & Water Level)	2
9	00-122674	Float Assy.	2
10	00-067500-00072	"O" Ring	2
11	00-328472	Box – Steam Heat	2
12	WS-010-40	Washer – Thrust	AR
13	WL-014-31	Lockwasher 1/2 External Shakeproof (SST)	AR
14	NS-018-28	Jam Nut 1/2-20 Hex Fin	AR
15	00-288465	Lid & Gasket Assy. (Incls. Item 16)	2
16	00-112007	Gasket	2
17	FE-024-61	Connector 45 Deg. (Non Metallic) "Sealtite"	2
		(1/2 Male Thd. x 1/2 Flex. Cnd.)	
18	FE-024-61	Connector 45 Deg. (Non Metallic) "Sealtite"	1
		(1/2 Male Thd. x 1/2 Flex. Cnd.)	
19	FE-024-65	Connector 90 Deg. (Non Metallic) "Sealtite"	1
		(1/2 Male Thd. x 1/2 Flex. Cnd.)	
20	SD-012-20	Self-Tapping Screw 8-32 x 1/2 Phil. Truss Hd., Type T	8
21	FE-024-67	Connector 90 Deg. (Non Metallic) "Sealtite"	4
		(1 Male Thd. x 1 Flex. Cnd.)	
22	FE-008-12	Gasket	2
*23	00-119244-00002	Cap	AR
*24	00-067500-00031	"O" Ring	AR
*25	WS-003-47	Washer	AR
*26	WL-006-17	Lockwasher 1/4 Medium	AR
*27	NS-015-01	Nut 1/4-20 Hex (SST)	AR
	00-294357-00001	Connector	AR
	00-294357-00002	Connector (Black)	AR
	00-065890-00029	Connector – Insulated	AR

*Use one set on CRS86A or CPW100A in place of items 1 thru 5 in wash tank and one set in rinse tank on all units.

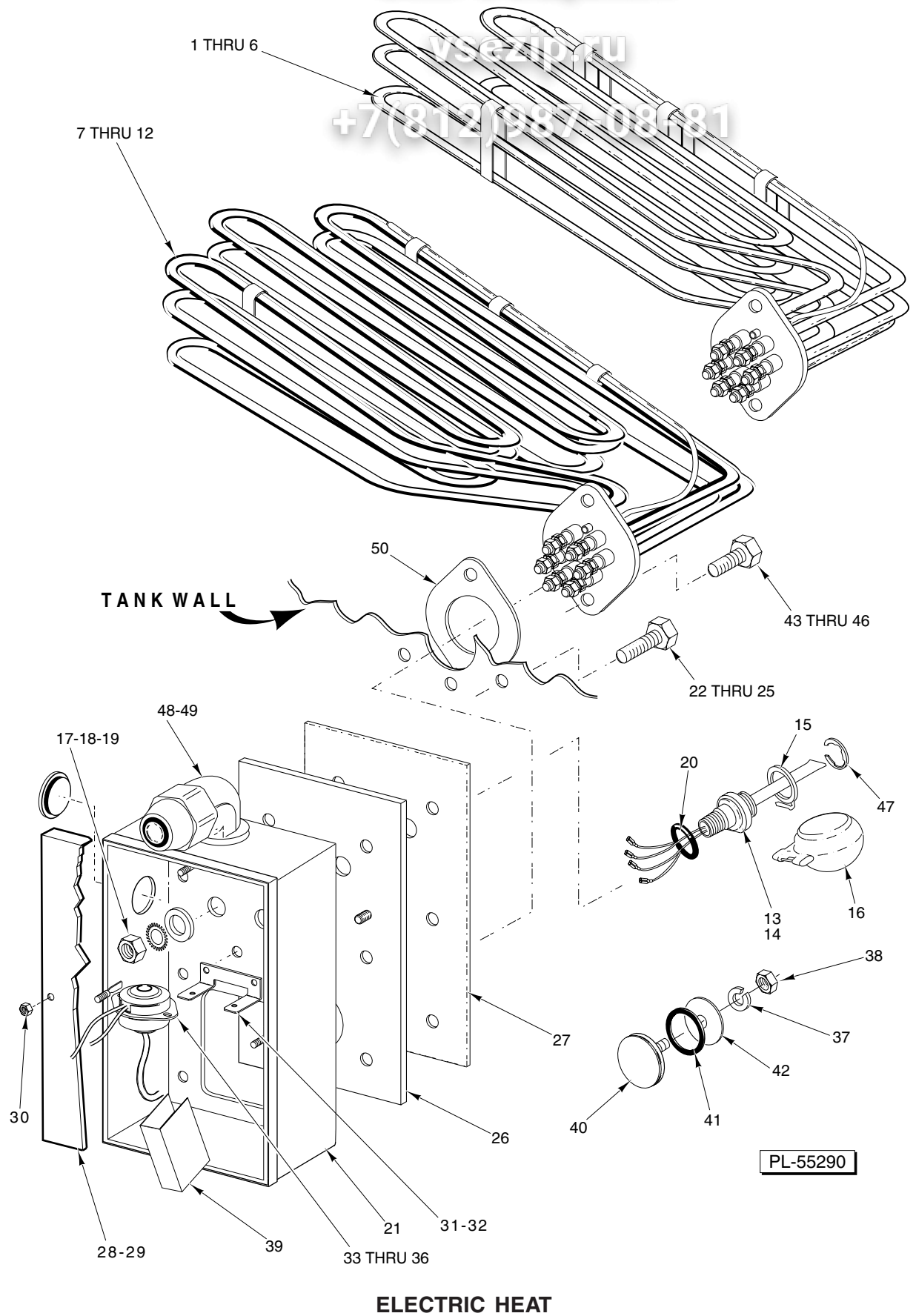

vsezip.ru

ELECTRIC HEAT

+7(812)987-08-81

ILLUS. PL-55290	PART	NAME OF PART	AMT.
1	00-436907-00001	Heater – Tank Electric (10K W/Rinse) (208 V., 60 Hz./200 V., 50 Hz.) (3 Ph.)	1
2	00-436907-00002	Heater – Tank Electric (10K W/Rinse) (240 V., 50/60 Hz.) (3 Ph.)	1
3	00-436907-00003	Heater – Tank Electric (10K W/Rinse) (208 V., 60 Hz./200 V., 50 Hz.) (1 Ph.)	1
4	00-436907-00004	Heater – Tank Electric (10K W/Rinse) (240 V., 50/60 Hz.) (1 Ph.)	1
5	00-436907-00005	Heater – Tank Electric (10K W/Rinse) (480 V., 60 Hz.) (3 Ph.)	1
6	00-436907-00006	Heater – Tank Electric (10K W/Rinse) (380 V., 50 Hz.) (3 Ph.)	1
7	00-435990-00001	Heater – Tank Electric (15K W/Wash) (208 V., 60 Hz./200 V., 50 Hz.) (3 Ph.)	1
8	00-435990-00002	Heater – Tank Electric (15K W/Wash) (240 V., 50/60 Hz.) (3 Ph.)	1
9	00-435990-00003	Heater – Tank Electric (15K W/Wash) (208 V., 60 Hz./200 V., 50 Hz.) (1 Ph.)	1
10	00-435990-00004	Heater – Tank Electric (15K W/Wash) (240 V., 50/60 Hz.) (1 Ph.)	1
11	00-435990-00005	Heater – Tank Electric (15K W/Wash) (480 V., 60 Hz.) (3 Ph.)	1
12	00-435990-00006	Heater – Tank Electric (15K W/Wash) (380 V., 50 Hz.) (3 Ph.)	1
13	00-271621	Probe & Switch Assy. (4 Wire) (Temperature & Water Level)	2
14	00-271622	Probe & Switch Assy. (2 Wire) (Water Level)	AR
15	00-112467	Retainer – Float	AR
16	00-122674	Float Assy.	AR
17	WS-010-40	Washer – Thrust	AR
18	WL-014-31	Lockwasher 1/2 External Shakeproof (SST)	AR
19	NS-018-28	Jam Nut 1/2-20 Hex Fin	AR
20	00-067500-00072	“O” Ring	AR
21	00-474512-00003	Box – Electric Heat	2
22	SC-041-15	Cap Screw 5/16-18 x 1 1/4 Hex Hd.	12
23	WS-029-05	Washer	24
24	WL-006-23	Lockwasher 5/16 Medium (SST)	12
25	NS-015-11	Nut 5/16-18 Hex	12
26	00-271118-00001	Plate – Mounting	2
27	00-271109	Gasket – Mounting	2
28	00-474574-00002	Lid & Gasket Assy. (Incls. Item 29)	2
29	00-474569	Gasket (Lid)	2
30	NS-031-15	Stop Nut 10-24 Hex (SST)	12
31	00-271122	Bracket – Thermostat	2
32	NS-031-15	Stop Nut 10-24 Hex (SST)	4
33	00-293946	Sleeve	2
34	00-271123	Protector – High Limit	2
35	SC-021-08	Mach. Screw 6-32 x 3/8 Rd. Hd. (SST)	4
36	NS-031-50	Stop Nut 6-32 Hex (SST)	4
*37	WL-006-17	Lockwasher 1/4 Medium	AR
*38	NS-015-01	Nut 1/4-20 Hex (SST)	AR
39	00-271168	Insulator – Terminal (Above 250 V.)	2
*40	00-119244-00002	Cap	AR
*41	00-067500-00031	“O” Ring	AR
*42	WS-003-47	Washer	AR
43	SC-041-13	Cap Screw 5/16-18 x 1 Hex Hd. (SST)	4
44	WS-017-08	Washer	4
45	WL-006-23	Lockwasher 5/16 Medium (SST)	4
46	NS-015-11	Nut 5/16-18 Hex	4
47	RR-010-13	Retaining Ring	AR
48	FE-008-12	Gasket	2
49	FE-024-63	Connector 90 Deg. (Non Metallic) “Sealtite” (1 Male Thd. x 1 Flex. Cnd.)	4
50	00-293598	Gasket – Heater Mounting	2
	00-526454	Foam Tape	AR
	00-545595	Sealer (1/8 Rd.)	AR
	00-294357-00001	Connector	AR
	00-294357-00002	Connector (Black)	AR
	00-065890-00029	Connector – Insulated	2

*Uses one set on CRS86A or CPW100A machines in place of item 14 in wash tank and one set in rinse tank on all units.

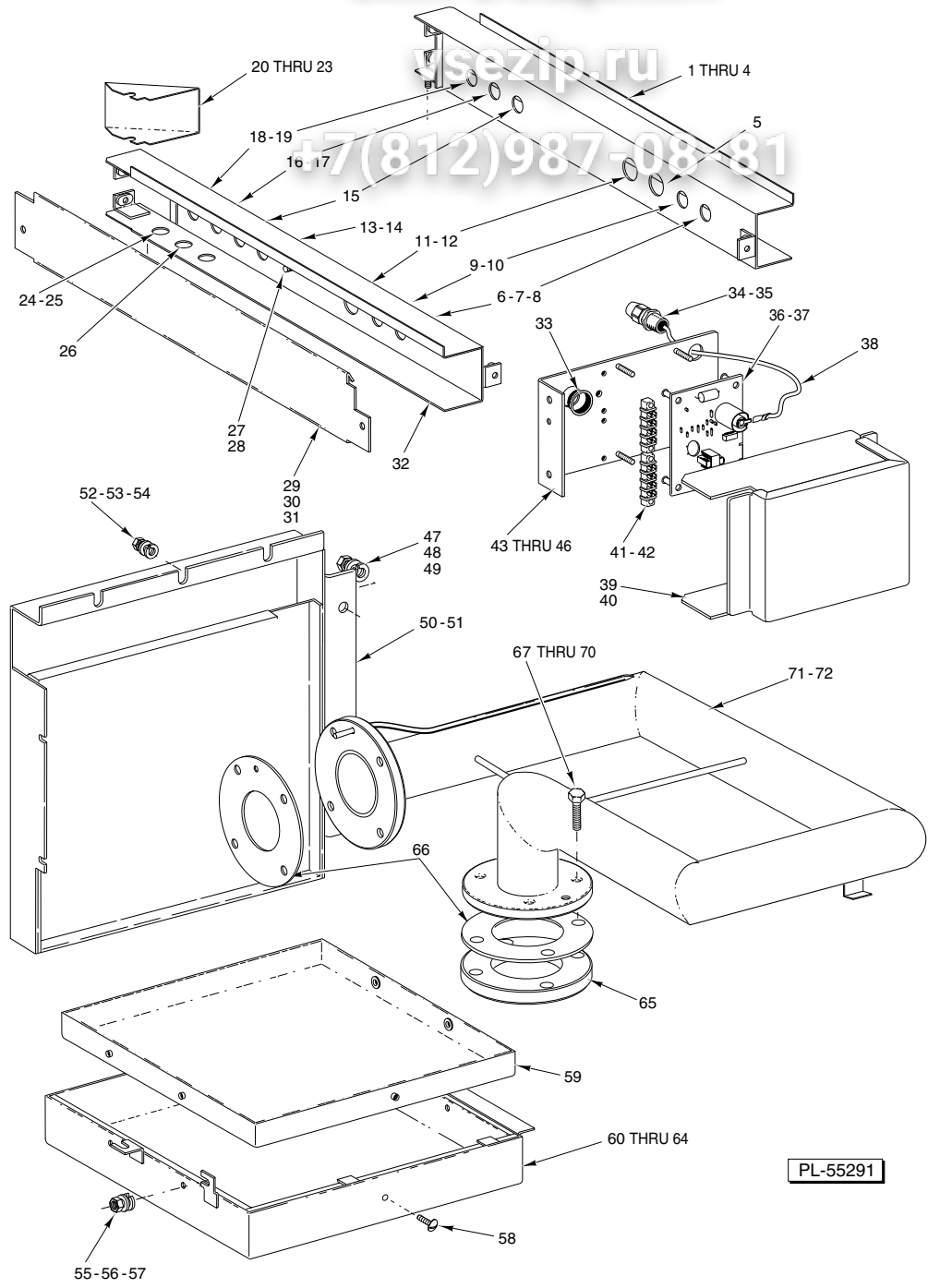

PL-55291

GAS HEAT BURNERS, FLUES, & WIREWAYS

ILLUS.	PART	NAME OF PART	AMT.
1	00-328461	Channel – Wireway (RH)	1
2	SC-041-10	Cap Screw ⁵ / ₁₆ -18 x ⁵ / ₈ Hex Hd.	2
3	SC-041-11	Cap Screw ⁵ / ₁₆ -18 x ³ / ₄ Hex Hd. (SST)	4
4	WL-006-23	Lockwasher ⁵ / ₁₆ Medium (SST)	6
5	FE-024-58	Connector Straight (Non Metallic) “Sealtite” (³ / ₄ Male Thd. x ³ / ₄ Flex. Cnd.)	2
6	FE-024-57	Connector Straight (Non Metallic) “Sealtite” (¹ / ₂ Male Thd. x ¹ / ₂ Flex. Cnd.)	2
7	FE-024-61	Connector 45 Deg. (Non Metallic) “Sealtite” (¹ / ₂ Male Thd. x ¹ / ₂ Flex. Cnd.)	2
8	FE-008-10	¹ / ₂ Gasket Assy.	2

GAS HEAT BURNERS, FLUES, & WIREWAYS

ILLUS. PL-55291	PART	NAME OF PART	AMT.
9	FE-024-57	Connector Straight (Non Metallic) "Sealtite" (1/2 Male Thd. x 1/2 Flex. Cnd.)	AR
10	FE-024-65	Connector 90 Deg. (Non Metallic) "Sealtite" (1/2 Male Thd. x 1/2 Flex. Cnd.)	AR
11	FE-024-62	Connector - Conduit 3/4 (Non Metallic) "Sealtite"	2
12	FE-024-58	Connector Straight (Non Metallic) "Sealtite" (3/4 Male Thd. x 3/4 Flex. Cnd.)	2
13	FE-024-57	Connector Straight (Non Metallic) "Sealtite" (1/2 Male Thd. x 1/2 Flex. Cnd.)	1
14	FE-024-61	Connector 45 Deg. (Non Metallic) "Sealtite" (1/2 Male Thd. x 1/2 Flex. Cnd.)	1
15	FE-024-61	Connector 45 Deg. (Non Metallic) "Sealtite" (1/2 Male Thd. x 1/2 Flex. Cnd.)	4
16	FE-024-57	Connector Straight (Non Metallic) "Sealtite" (1/2 Male Thd. x 1/2 Flex. Cnd.)	2
17	FE-024-61	Connector 45 Deg. (Non Metallic) "Sealtite" (1/2 Male Thd. x 1/2 Flex. Cnd.)	2
18	FE-024-57	Connector Straight (Non Metallic) "Sealtite" (1/2 Male Thd. x 1/2 Flex. Cnd.)	2
19	FE-024-61	Connector 45 Deg. (Non Metallic) "Sealtite" (1/2 Male Thd. x 1/2 Flex. Cnd.)	2
20	00-328437	Cover - Wireway	2
21	WS-003-49	Washer	2
22	WL-006-17	Lockwasher 1/4 Medium	2
23	NS-015-01	Nut 1/4-20 Hex (SST)	2
24	FE-024-57	Connector Straight (Non Metallic) "Sealtite" (1/2 Male Thd. x 1/2 Flex. Cnd.)	1
25	FE-024-65	Connector 90 Deg. (Non Metallic) "Sealtite" (1/2 Male Thd. x 1/2 Flex. Cnd.)	1
26	PB-004-08	Plug Button Heyco 2703	AR
27	WL-014-10	Lockwasher 1/4 External Shakeproof	1
28	NS-031-21	Stop Nut - Special 1/4-20 Hex	1
29	00-328452-00001	Cover - Wireway Channel (LH)	1
30	00-328452-00002	Cover - Wireway Channel (RH)	1
31	SC-053-05	Mach. Screw 10-24 x 3/8 Truss Hd., Slotted	4
32	00-328464	Channel - Wireway (LH)	1
33	FE-024-75	Bushing - Electrical Snap (1)	2
34	FE-024-57	Connector Straight (Non Metallic) "Sealtite" (1/2 Male Thd. x 1/2 Flex. Cnd.)	2
35	FE-024-61	Connector 45 Deg. (Non Metallic) "Sealtite" (1/2 Male Thd. x 1/2 Flex. Cnd.)	2
36	00-436853	Ignitor Board 24 VAC	2
37	NS-031-50	Stop Nut 6-32 Hex (SST)	8
38	00-271146-00002	Cable - High Voltage	2
39	00-328459	Cover - Ignitor Board	2
40	SC-053-05	Mach. Screw 10-24 x 3/8 Truss Hd., Slotted	2
41	00-294325-014-1	Block - Terminal	4
42	SC-021-15	Mach. Screw 8-32 x 1/2 Rd. Hd., Slotted	8
43	00-328462-00001	Bracket - Ignitor Board (LH)	1
44	00-328462-00002	Bracket - Ignitor Board (RH)	1
45	SC-041-11	Cap Screw 5/16-18 x 3/4 Hex Hd. (SST)	4
46	WL-006-23	Lockwasher 5/16 Medium (SST)	4
47	WS-017-01	Washer	2
48	WL-006-23	Lockwasher 5/16 Medium (SST)	2
49	NS-015-11	Nut 5/16-18 Hex	2
50	00-328455-00001	Flue (LH)	1
51	00-328455-00002	Flue (RH)	1
52	WS-003-49	Washer	10
53	WL-006-17	Lockwasher 1/4 Medium	10
54	NS-015-01	Nut 1/4-20 Hex (SST)	10
55	WS-003-49	Washer	4
56	WL-006-17	Lockwasher 1/4 Medium	4
57	NS-015-01	Nut 1/4-20 Hex (SST)	4
58	SC-053-02	Mach. Screw 10-24 x 1/2 Truss Hd. (SST)	10
59	00-328415	Liner - Shroud	2
60	00-328416	Insulation	2
61	00-328453-00001	Shroud (LH)	1
62	00-328453-00002	Shroud (RH)	1
63	00-328454-00001	Shroud Assy. (LH) (Incls. Items 58, 59, 60, & 61)	1
64	00-328454-00002	Shroud Assy. (RH) (Incls. Items 48, 59, 60, & 62)	1
65	00-435952	Flange - Immersion Tube	2
66	00-436100	Gasket	4
67	SC-121-43	Cap Screw 7/16-14 x 1 3/4 Hex Hd.	16
68	WS-021-07	Washer	32
69	WL-019-77	Lockwasher 7/16 Medium	16
70	NS-047-97	Nut 7/16-14 Hex	16
71	00-328460-00001	Tube - Immersion (LH)	1
72	00-328460-00002	Tube - Immersion (RH)	1

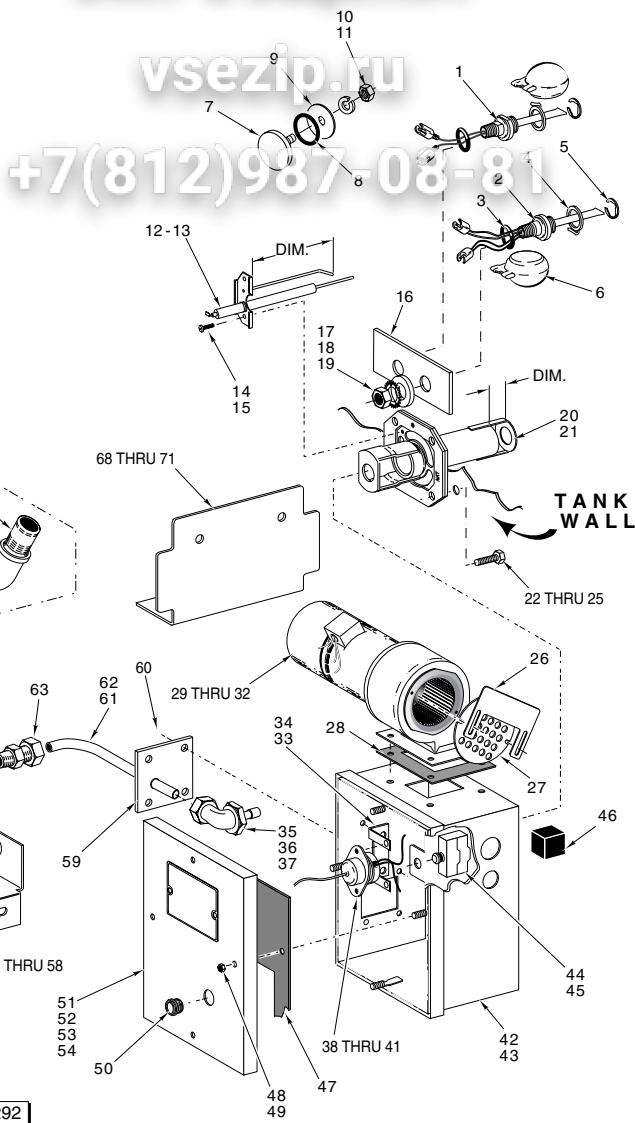

GAS HEAT COMPONENTS

ILLUS.	PART	NAME OF PART	AMT.
PL-55292			
1	00-328495	Probe & Switch Assy. (2 Wire) (Water Level) (Must Order 2 Jumper Wires Part #328758)	AR
2	00-271621	Probe & Switch Assy. (4 Wire) (Temperature & Water Level)	2
3	00-067500-00072	"O" Ring	AR
4	00-112467	Retainer – Float	AR
5	RR-010-13	Retaining Ring	AR
6	00-122674	Float Assy.	AR
*7	00-119244-00002	Cap	AR
*8	00-067500-00031	"O" Ring	AR
*9	WS-003-47	Washer	AR
*10	WL-006-17	Lockwasher 1/4 Medium	AR
*11	NS-015-01	Nut 1/4-20 Hex (SST)	AR
12	00-436792	Electrode Ignition – Natural Gas (Dim. 3 1/8) (Marked 665)	2
13	00-436067	Electrode Ignition – L.P. Gas (Dim. 3 3/8) (Marked 662)	2
14	SC-093-03	Mach. Screw 8-32 x 3/8 Phil. Pan Hd. (SST)	4
15	WL-014-05	Lockwasher #8 External Shakeproof	4
16	00-435960-00001	Plate Spacer	2
17	NS-018-28	Jam Nut 1/2-20 Hex	AR
18	WL-014-31	Lockwasher 1/2 External Shakeproof (SST)	AR

GAS HEAT COMPONENTS

LLUS. PL-55292	PART	NAME OF PART	AMT.
19	WS-010-40	Washer – Thrust	AR
20	00-328649	Bracket – Orifice (Nat. Gas) (Shown) (Dim. 1/2) (Marked NAT)	2
21	00-436761	Bracket – Orifice (L.P. Gas) (Dim. 1/2) (Marked LP)	2
22	SC-121-43	Cap Screw 7/16-14 x 1 3/4 Hex Hd.	16
23	WS-021-07	Washer	32
24	WL-019-77	Lockwasher 7/16 Medium	16
25	NS-047-97	Nut 7/16-14 Hex	16
26	00-328428	Plate – Adjusting	2
27	00-328427	Plate – Restrictor	2
28	00-328473	Gasket – Blower	2
29	00-328476-00001	Blower – Motor	2
30	SC-041-05	Cap Screw 1/4-20 x 5/8 Hex Hd.	8
31	WL-014-10	Lockwasher 1/4 External Shakeproof	2
32	NS-031-21	Stop Nut – Special 1/4-20 Hex	8
33	00-271122-00002	Bracket – Thermostat	2
34	SC-053-05	Mach. Screw 10-24 x 3/8 Truss Hd., Slotted	8
35	00-435701-00003	Angle Fitting (Nat. Gas, 60 Hz.) #25 Drill (0.1495)	2
36	00-435701-00004	Angle Fitting (Nat. Gas, 50 Hz.) #29 Drill (0.136)	2
37	00-435701-00002	Angle Fitting (L.P. Gas 50/60 Hz.) #43 Drill (0.089)	2
38	00-271123	Protector – High Limit	2
39	00-293946	Sleeve – Lead	2
40	SC-127-26	Mach. Screw 6-32 x 3/8 Rd. Hd. (SST)	4
41	NS-031-50	Stop Nut 6-32 Hex (SST)	4
42	00-328465	Box – Gas Heat (LH)	1
43	00-328466	Box – Gas Heat (RH)	1
44	00-087711-153-1	Switch – Limit	2
45	00-328508	Insulator – Switch	2
46	00-328450	Plug – Rubber (Conduit)	8
47	00-328429	Gasket – Lid	2
48	WS-019-06	Washer	8
49	NS-031-16	Stop Nut 10-24 “Elastic” (SST)	8
50	00-435024	Eye	2
51	00-328467-00001	Lid – Gas Heat Box (Nat. Gas, 60 Hz.)	2
52	00-328467-00002	Lid – Gas Heat Box (Nat. Gas, 50 Hz.)	2
53	00-328467-00003	Lid – Gas Heat Box (L.P. Gas, 60 Hz.)	2
54	00-328467-00004	Lid – Gas Heat Box (L.P. Gas, 50 Hz.)	2
55	00-328212	Bracket – Valve	2
56	SC-041-10	Cap Screw 5/16-18 x 5/8 Hex Hd.	4
57	WL-006-23	Lockwasher 5/16 Medium (SST)	4
58	NS-015-11	Nut 5/16-18 Hex	4
59	00-328440	Plate – Gas Line	2
60	SC-053-05	Mach. Screw 10-24 x 3/8 Truss Hd., Slotted	8
61	00-328425-00002	Tube – Gas (LH Tank)	1
62	00-328425	Tube – Gas (RH Tank)	1
63	00-435702	Connector – Special	2
64	00-328426-00001	Gas Valve (Nat. Gas)	2
65	00-328426-00002	Gas Valve (L.P. Gas, 60 Hz.)	2
66	00-328426-00003	Gas Valve (L.P. Gas, 50 Hz.)	2
67	00-291988-00003	Valve – Gas Cock	2
68	00-328421	Deflector – Flue	2
69	WS-003-49	Washer	4
70	WL-006-17	Lockwasher 1/4 Medium	4
71	NS-015-01	Nut 1/4-20 Hex (SST)	4
72	FP-035-94	Pipe 1/2 x 1 1/2 Lg. TBE	2
73	FP-019-33	Tee 3/4 x 3/4 x 1/2 Reducing	1
74	FP-059-61	Pipe 1/2 x 1 1/4 Lg. TBE	1
75	FP-022-11	Union – Pipe	2
76	FP-059-61	Pipe 1/2 x 1 1/4 Lg. TBE	2
77	FP-013-15	Elbow – Pipe 1/2 x 90 Deg.	2
78	FP-059-61	Pipe 1/2 x 1 1/4 Lg. TBE	2
79	FP-059-61	Pipe 1/2 x 1 1/4 Lg. TBE	1
80	FP-078-89	Elbow 3/4 NPT x 1/2 Reducing	1
81	FP-087-27	Nipple 3/4 x 61 TBE	1
	00-294357-00001	Connector	2
	00-294357-00002	Connector (Black)	2
	00-435538	Wire Harness – Ignitor Board	2
	00-328758	Jumper Wire – Socket Type Connector (Use With Item 39)	2

*Use one set on CCS, CRS86A/W, or CPW100A/W machines in place of item 1 in wash tank and one set in rinse tank on all units.

vsezip.ru

+7(812)987-08-81

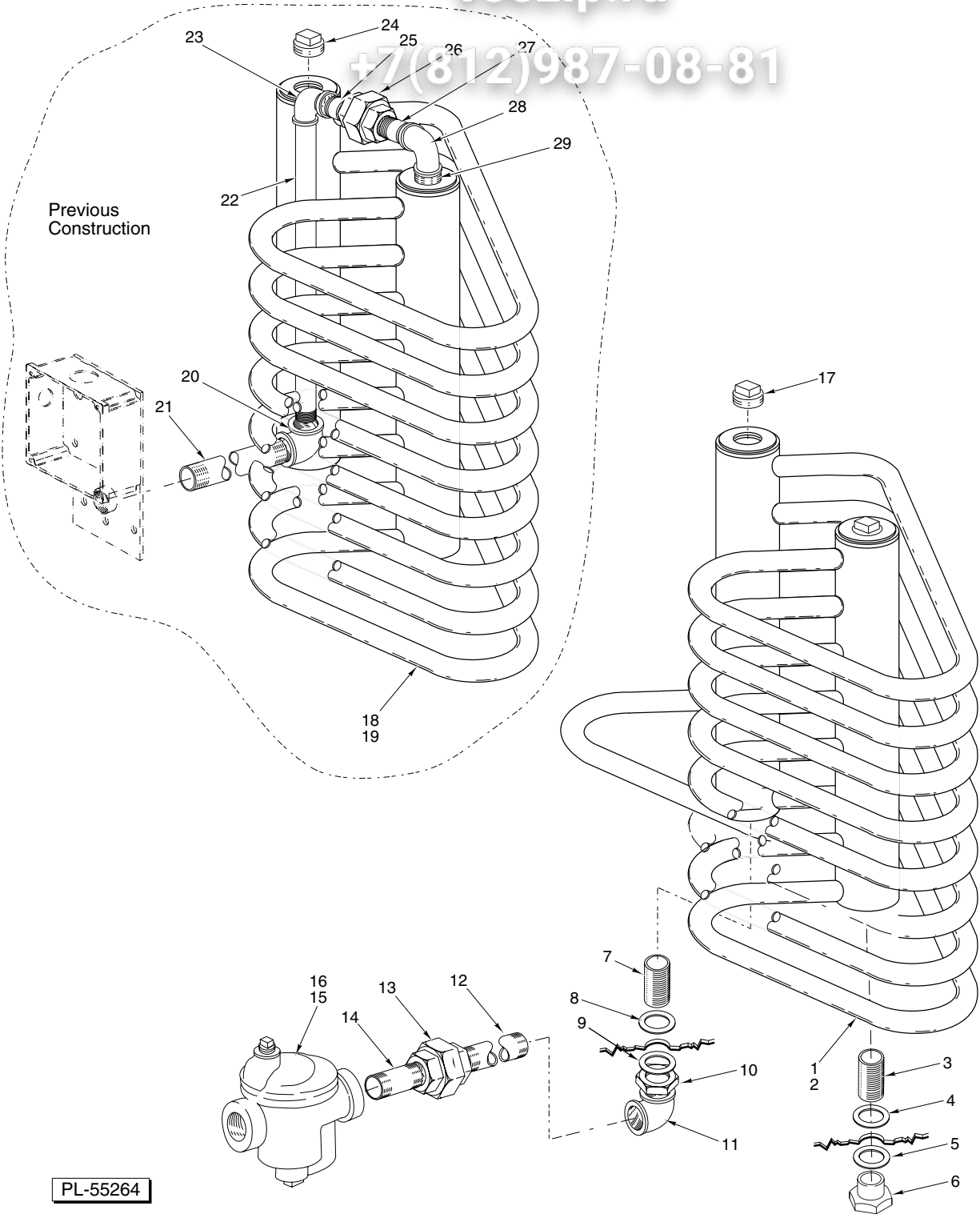

**STEAM COILS
(2 UNITS REQUIRED)**

vsezip.ru

+7(812)987-08-81

**STEAM COILS
(2 UNITS REQUIRED)**

ILLUS. PL-55264	PART NO.	NAME OF PART	AMT.
1	00-328823-00001	Coil – Steam (LH Tank) (Shown)	1
2	00-328823-00002	Coil – Steam (RH Tank)	1
3	FP-080-17	Nipple ³ / ₄ x 2 (TBE; 1 ¹ / ₂ R.T.O.E.) (SST)	1
4	WS-013-45	Washer	1
5	WS-013-45	Washer	1
6	FP-053-09	Lock Nut ³ / ₄ NPSL Pipe (SST)	1
7	FP-080-17	Nipple ³ / ₄ x 2 (TBE; 1 ¹ / ₂ R.T.O.E.) (SST)	1
8	WS-013-45	Washer	1
9	WS-013-45	Washer	1
10	FP-053-09	Lock Nut ³ / ₄ NPSL Pipe (SST)	1
11	FP-013-22	Elbow ³ / ₄ x 90 Deg.	1
12	FP-059-64	Nipple ³ / ₄ x 5 ¹ / ₂ TBE	1
13	FP-022-17	Union ³ / ₄ (Grd. Seat)	1
14	FP-036-92	Nipple ³ / ₄ x 1 ³ / ₈ TBE	1
15	00-118316	Steam Trap (0-20 P.S.I.)	1
16	00-118317	Steam Trap (21-50 P.S.I.)	1
17	FP-052-09	Pipe Plug ³ / ₄ Sq. Hd. (SST)	1
18	00-437158-00001	Coil – Steam (LH Tank) (Shown)	1
19	00-437158-00002	Coil – Steam (RH Tank)	1
20	FP-049-15	Elbow ³ / ₄ x 90 Deg. (SST)	1
21	FP-054-44	Nipple ³ / ₄ x 2 ¹ / ₂ TBE (SST)	1
22	FP-087-11	Nipple ³ / ₄ x 9 ¹ / ₂ TBE (SST)	1
23	FP-049-15	Elbow ³ / ₄ x 90 Deg. (SST)	1
24	FP-052-09	Pipe Plug ³ / ₄ Sq. Hd. (SST)	1
25	FP-054-27	Nipple ³ / ₄ x 1 ³ / ₈ TBE (SST)	1
26	FP-050-14	Union ³ / ₄ (Grd. Seat) (SST)	1
27	FP-054-27	Nipple ³ / ₄ x 1 ³ / ₈ TBE (SST)	1
28	FP-049-15	Elbow ³ / ₄ x 90 Deg. (SST)	1
29	FP-054-27	Nipple ³ / ₄ x 1 ³ / ₈ TBE (SST)	1

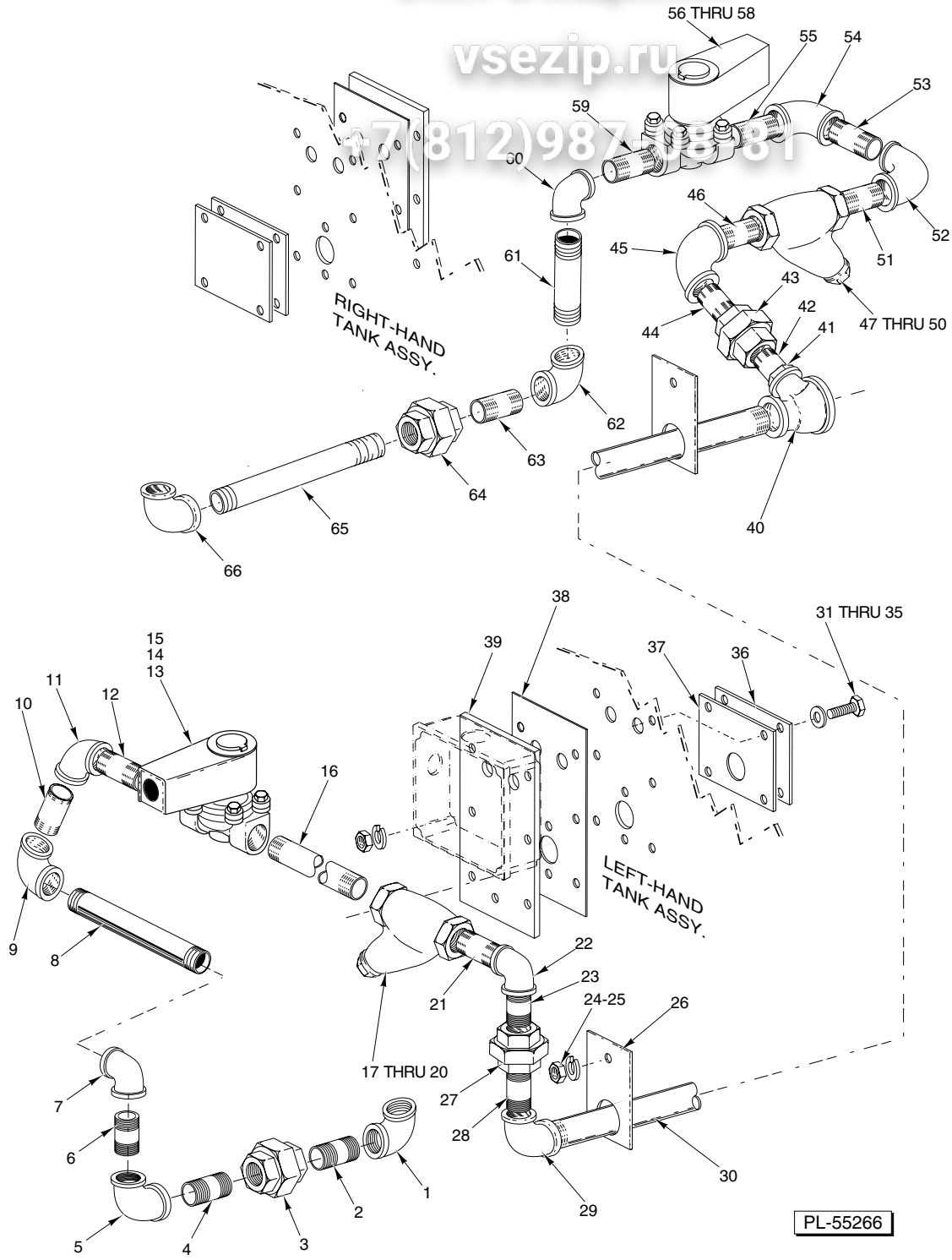

STEAM COIL PIPING

ILLUS.	PART	NAME OF PART	AMT.
PL-55266			
1	FP-013-22	Elbow 3/4 x 90 Deg.	1
2	FP-036-12	Nipple 3/4 x 7 3/4 TBE	1
3	FP-022-17	Union 3/4 (Grd. Seat)	1
4	FP-036-05	Nipple 3/4 x 3 TBE	1

STEAM COIL PIPING

vsezip.ru

+7(812)987-08-81

ILLUS.	PART	NAME OF PART	AMT.
	PL-55266		
5	FP-013-22	Elbow $\frac{3}{4}$ x 90 Deg.	1
6	FP-036-03	Nipple $\frac{3}{4}$ x 2 $\frac{3}{4}$ TBE	1
7	FP-013-22	Elbow $\frac{3}{4}$ x 90 Deg.	1
8	FP-080-81	Nipple $\frac{3}{4}$ x 8 $\frac{1}{4}$ TBE	1
9	FP-013-22	Elbow $\frac{3}{4}$ x 90 Deg.	1
10	FP-036-05	Nipple $\frac{3}{4}$ x 3 TBE	1
11	FP-013-22	Elbow $\frac{3}{4}$ x 90 Deg.	1
12	FP-036-92	Nipple $\frac{3}{4}$ x 1 $\frac{3}{8}$ TBE	1
13	00-270329-00001	Solenoid Valve (120 V.) (Incls. Items 14 & 15)	1
14	00-270318-00001	Coil – Solenoid Valve (120 V.)	1
15	00-270336	Service Kit – Solenoid Valve	1
16	FP-059-64	Nipple $\frac{3}{4}$ x 5 $\frac{1}{2}$ TBE	1
17	00-186922	Line Strainer (Incls. Items 18, 19, & 20)	1
18	00-186923	Plug – Branch	1
19	00-186924	Gasket – Branch Plug	1
20	00-186925	Screen – Line Strainer	1
21	FP-036-92	Nipple $\frac{3}{4}$ x 1 $\frac{3}{8}$ TBE	1
22	FP-013-22	Elbow $\frac{3}{4}$ x 90 Deg.	1
23	FP-036-05	Nipple $\frac{3}{4}$ x 3 TBE	1
24	WL-006-17	Lockwasher $\frac{1}{4}$ Medium	2
25	NS-015-01	Nut $\frac{1}{4}$ -20 Hex (SST)	2
26	00-289783	Bracket – Pipe Support	2
27	FP-022-17	Union $\frac{3}{4}$ (Grd. Seat)	1
28	FP-036-95	Nipple $\frac{3}{4}$ x 2 TBE	1
29	FP-079-97	Elbow – Reducing 90 Deg. 1 to $\frac{3}{4}$	1
30	FP-075-90	Nipple 1 x 39 $\frac{1}{2}$ TBE	1
31	SC-041-15	Cap Screw $\frac{5}{16}$ -18 x 1 $\frac{1}{4}$ Hex Hd.	14
32	WS-017-08	Washer	28
33	WL-006-23	Lockwasher $\frac{5}{16}$ Medium (SST)	14
34	NS-015-11	Nut $\frac{5}{16}$ -18 Hex	14
35	00-545595	Sealer ($\frac{1}{8}$ Rd.)	AR
36	00-328777	Plate – Inner	2
37	00-435026	Gasket	2
38	00-271109	Gasket – Mounting	2
39	00-328776	Plate – Outer	2
40	FP-019-76	Tee – Pipe 1 $\frac{1}{2}$ x 1 x 1	1
41	FP-026-26	Bushing 1 to $\frac{3}{4}$	1
42	FP-036-92	Nipple $\frac{3}{4}$ x 1 $\frac{3}{8}$ TBE	1
43	FP-022-17	Union $\frac{3}{4}$ (Grd. Seat)	1
44	FP-036-92	Nipple $\frac{3}{4}$ x 1 $\frac{3}{8}$ TBE	1
45	FP-013-22	Elbow $\frac{3}{4}$ x 90 Deg.	1
46	FP-036-92	Nipple $\frac{3}{4}$ x 1 $\frac{3}{8}$ TBE	1
47	00-186922	Line Strainer (Incls. Items 48, 49, & 50)	1
48	00-186923	Plug – Branch	1
49	00-186924	Gasket – Branch Plug	1
50	00-186925	Screen – Line Strainer	1
51	FP-036-92	Nipple $\frac{3}{4}$ x 1 $\frac{3}{8}$ TBE	1
52	FP-013-22	Elbow $\frac{3}{4}$ x 90 Deg.	1
53	FP-036-92	Nipple $\frac{3}{4}$ x 1 $\frac{3}{8}$ TBE	1
54	FP-013-22	Elbow $\frac{3}{4}$ x 90 Deg.	1
55	FP-036-92	Nipple $\frac{3}{4}$ x 1 $\frac{3}{8}$ TBE	1
56	00-270329-00001	Solenoid Valve (120 V.) (Incls. Items 57 & 58)	1
57	00-270318-00001	Coil – Solenoid Valve (120 V.)	1
58	00-270336	Service Kit – Solenoid Valve	1
59	FP-036-92	Nipple $\frac{3}{4}$ x 1 $\frac{3}{8}$ TBE	1
60	FP-013-22	Elbow $\frac{3}{4}$ x 90 Deg.	1
61	FP-078-38	Nipple $\frac{3}{4}$ x 3 $\frac{3}{4}$ TBE	1
62	FP-013-22	Elbow $\frac{3}{4}$ x 90 Deg.	1
63	FP-036-05	Nipple $\frac{3}{4}$ x 3 TBE	1
64	FP-022-17	Union $\frac{3}{4}$ (Grd. Seat)	1
65	FP-036-12	Nipple $\frac{3}{4}$ x 7 $\frac{3}{4}$ TBE	1
66	FP-013-22	Elbow $\frac{3}{4}$ x 90 Deg.	1

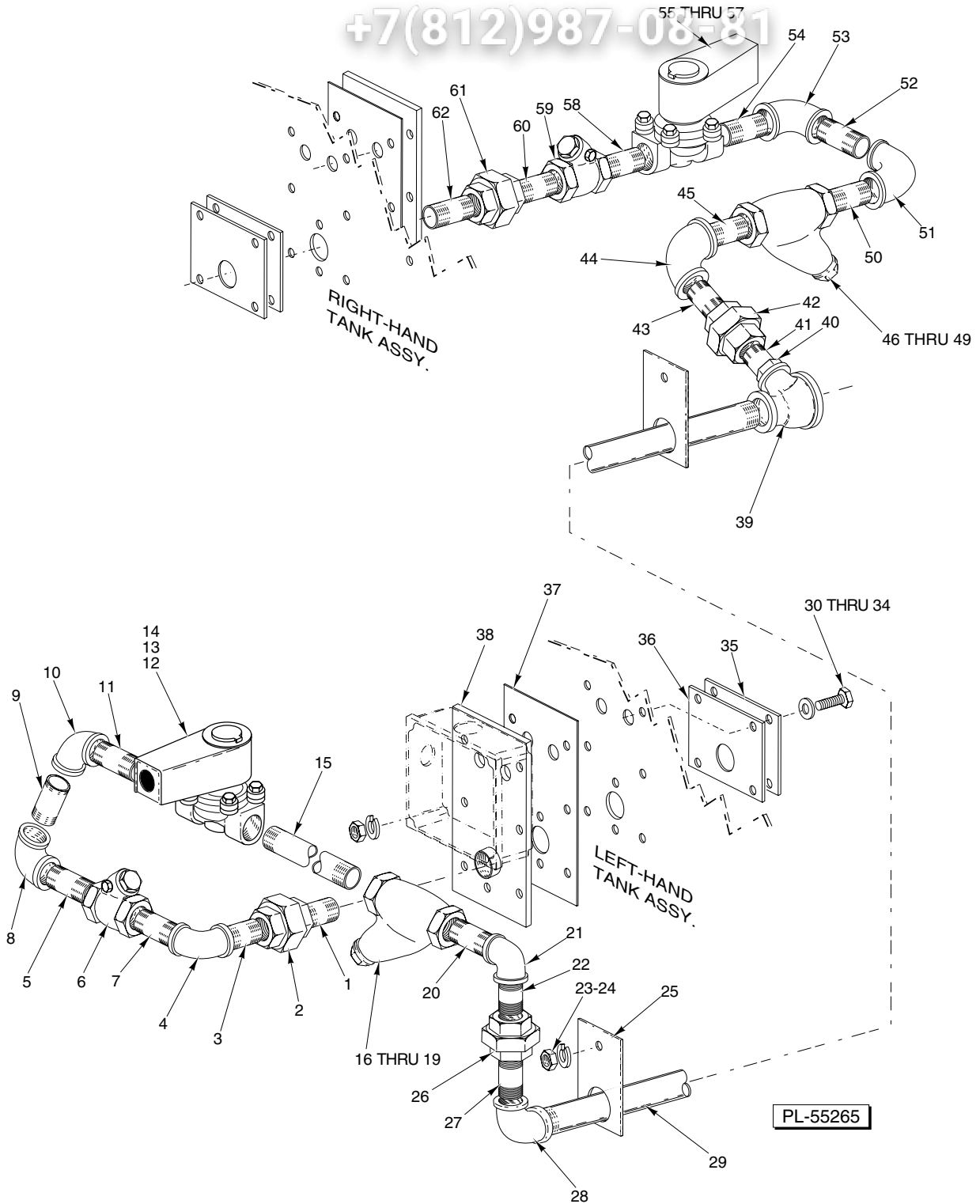

**STEAM INJECTOR & PREVIOUS
CONSTRUCTION STEAM COIL PIPING**

**STEAM INJECTOR & PREVIOUS
CONSTRUCTION STEAM COIL PIPING**

ILLUS.	PART	NAME OF PART	AMT.
PL-55265			
1	FP-036-92	Nipple 3/4 x 1 3/8 TBE	1
2	FP-022-17	Union 3/4 (Grd. Seat)	1
3	FP-036-92	Nipple 3/4 x 1 3/8 TBE	1
4	FP-013-22	Elbow 3/4 x 90 Deg.	1
5	FP-036-92	Nipple 3/4 x 1 3/8 TBE	1
6	00-074696	Check Valve 3/4	1
7	FP-036-95	Nipple 3/4 x 2 TBE	1
8	FP-013-22	Elbow 3/4 x 90 Deg.	1
9	FP-036-92	Nipple 3/4 x 1 3/8 TBE	1
10	FP-013-22	Elbow 3/4 x 90 Deg.	1
11	FP-036-92	Nipple 3/4 x 1 3/8 TBE	1
12	00-270329-00001	Solenoid Valve (120 V.) (Incls. Items 13 & 14)	1
13	00-270318-00001	Coil – Solenoid Valve (120 V.)	1
14	00-270336	Service Kit – Solenoid Valve	1
15	FP-059-64	Nipple 3/4 x 5 1/2 TBE	1
16	00-186922	Line Strainer (Incls. Items 17, 18, & 19)	1
17	00-186923	Plug – Branch	1
18	00-186924	Gasket – Branch Plug	1
19	00-186925	Screen – Line Strainer	1
20	FP-036-92	Nipple 3/4 x 1 3/8 TBE	1
21	FP-013-22	Elbow 3/4 x 90 Deg.	1
22	FP-036-92	Nipple 3/4 x 1 3/8 TBE	1
23	WL-006-17	Lockwasher 1/4 Medium	2
24	NS-015-01	Nut 1/4-20 Hex (SST)	2
25	00-289783	Bracket – Pipe Support	2
26	FP-022-17	Union 3/4 (Grd. Seat)	1
27	FP-036-95	Nipple 3/4 x 2 TBE	1
28	FP-079-97	Elbow – Reducing 90 Deg. 1 to 3/4	1
29	FP-075-90	Nipple 1 x 39 1/2 TBE	1
30	SC-041-15	Cap Screw 5/16-18 x 1 1/4 Hex Hd.	14
31	WS-017-08	Washer	28
32	WL-006-23	Lockwasher 5/16 Medium (SST)	14
33	NS-015-11	Nut 5/16-18 Hex	14
34	00-545595	Sealer	AR
35	00-435027	Plate	2
36	00-435026	Gasket	2
37	00-271109	Gasket – Mounting	2
38	00-271108	Plate – Mounting	2
39	FP-019-76	Tee-Pipe 1 1/2 x 1 x 1	1
40	FP-026-26	Bushing 1 to 3/4	1
41	FP-036-92	Nipple 3/4 x 1 3/8 TBE	1
42	FP-022-17	Union 3/4 (Grd. Seat)	1
43	FP-036-92	Nipple 3/4 x 1 3/8 TBE	1
44	FP-013-22	Elbow 3/4 x 90 Deg.	1
45	FP-036-92	Nipple 3/4 x 1 3/8 TBE	1
46	00-186922	Line Strainer (Incls. Items 47, 48, & 49)	1
47	00-186923	Plug – Branch	1
48	00-186924	Gasket – Branch Plug	1
49	00-186925	Screen – Line Strainer	1
50	FP-036-92	Nipple 3/4 x 1 3/8 TBE	1
51	FP-013-22	Elbow 3/4 x 90 Deg.	1
52	FP-036-92	Nipple 3/4 x 1 3/8 TBE	1
53	FP-013-22	Elbow 3/4 x 90 Deg.	1
54	FP-036-92	Nipple 3/4 x 1 3/8 TBE	1
55	00-270329-00001	Solenoid Valve (120 V.) (Incls. Items 56 & 57)	1
56	00-270318-00001	Coil – Solenoid Valve (120 V.)	1
57	00-270336	Service Kit – Solenoid Valve	1
58	FP-036-92	Nipple 3/4 x 1 3/8 TBE	1
59	00-074696	Check Valve 3/4	1
60	FP-036-92	Nipple 3/4 x 1 3/8 TBE	1
61	FP-022-17	Union 3/4 (Grd. Seat)	1
62	FP-036-92	Nipple 3/4 x 1 3/8 TBE	1

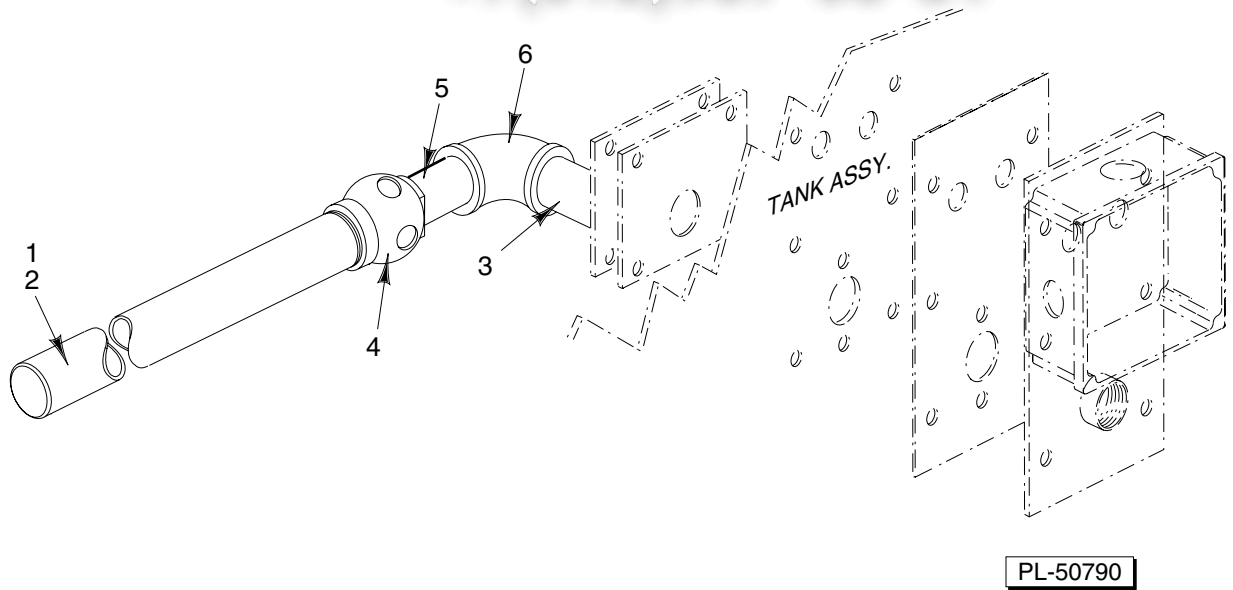

**STEAM INJECTOR HEAT
(2 UNITS REQUIRED)**

ILLUS.	PART	NAME OF PART	AMT.
PL-50790			
1	00-271110	Piping – Steam Injector (Incls. Items 2, 4, & 5)	1
2	FP-085-05	Nipple 1 x 10 1/2 STOE (SST)	1
3	FP-080-22	Nipple 3/4 x 6 1/4 Lg. (TBE) (SST)	1
4	00-288671	Silent Water Heater Assy.	1
5	FP-054-44	Nipple 3/4 x 2 1/2 (TBE) (SST)	1
6	FP-049-15	Elbow 3/4 x 90 Deg. (SST)	1
	00-546292	Sealer – Pipe	AR
	00-545595	Sealer (1/8 Rd.)	AR

vsezip.ru

+7(812)987-08-81

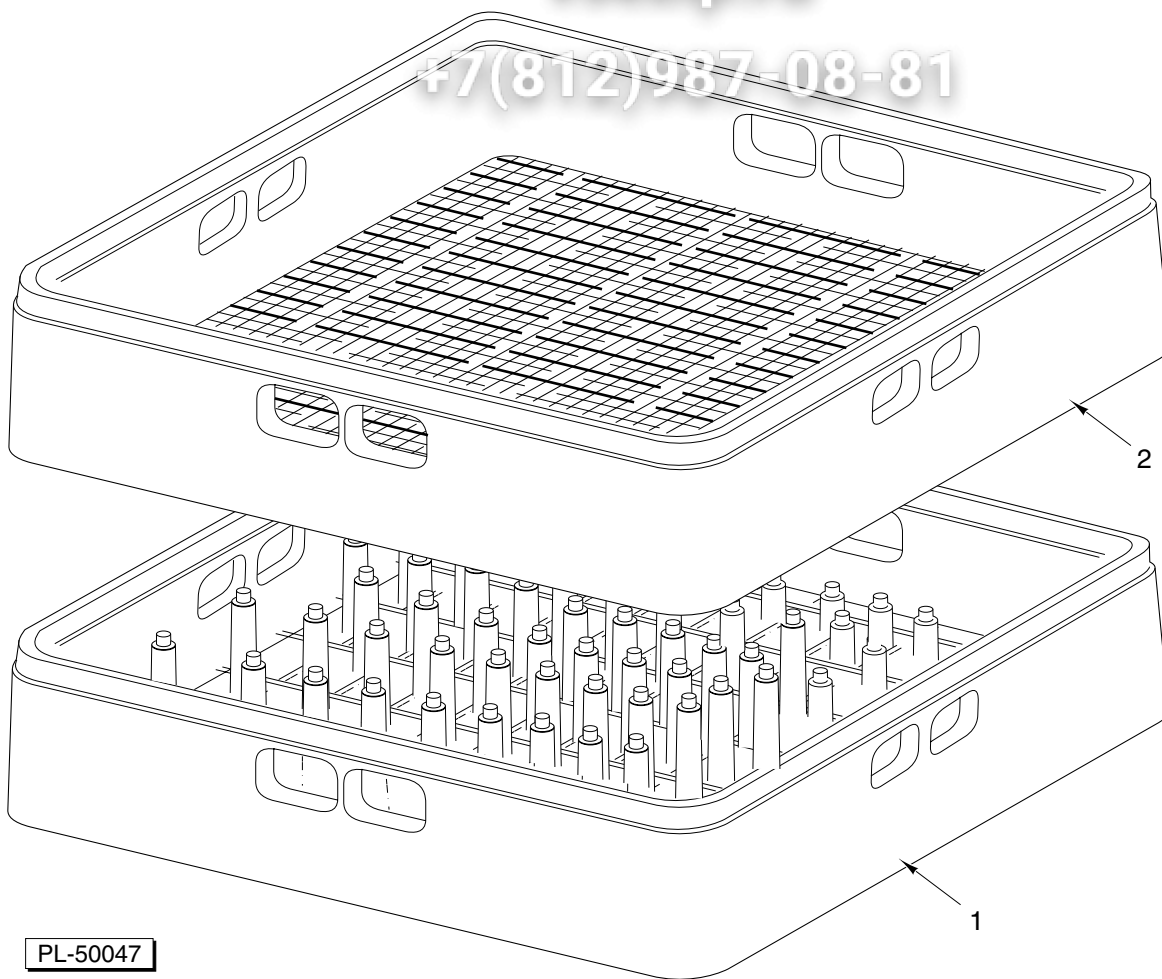

DISH RACKS

ILLUS.	PART	NAME OF PART	AMT.
PL-50047			
1	00-315191	Rack – Peg (Packaged)	1
2	00-315193	Rack – Combination (Packaged)	1
	00-295288	Peg Type Tray Rack (P1400) (Packaged)	1
	00-276043	Rack Assy. (250 Tx) (Tray & Bun Pans)	1

vsezip.ru

+7(812)987-08-81