

Зип Общепит

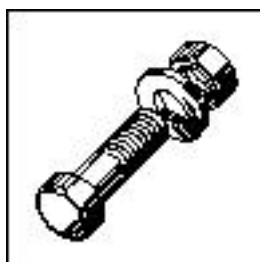

FM30 / FM30U



Spare Parts

Solenoid Valve - FM30.....	4 - 5
Anti-Siphon-Device - FM30.....	6 - 7
Solenoid Valve - FM30U.....	8 - 9
Anti-Siphon-Device - FM30U.....	10 - 11
Booster	12 - 15
Wash & Rinse System.....	16 - 19
Strainer System, Drain.....	20 - 21
Wash Pump.....	22 - 23
Electric Parts.....	24 - 27
Transformer.....	28 - 29
Hood Lift Unit , End Switch.....	30 - 31
End Switch, Door Spring.....	32 - 33
Rinse Booster Pump.....	34 - 37
Detergent-Dispenser - FM30.....	38 - 39
Rinse Agent Dispenser - FM30.....	40 - 41
Detergent-Dispenser - FM30U.....	42 - 43
Rinse Agent Dispenser - FM30U.....	44 - 45
Drain Pump - FM30U.....	46 - 47
Panel, Extension Piece.....	48 - 49
Supporting Frame - FM30U.....	50 - 51

+7(812)987-08-81

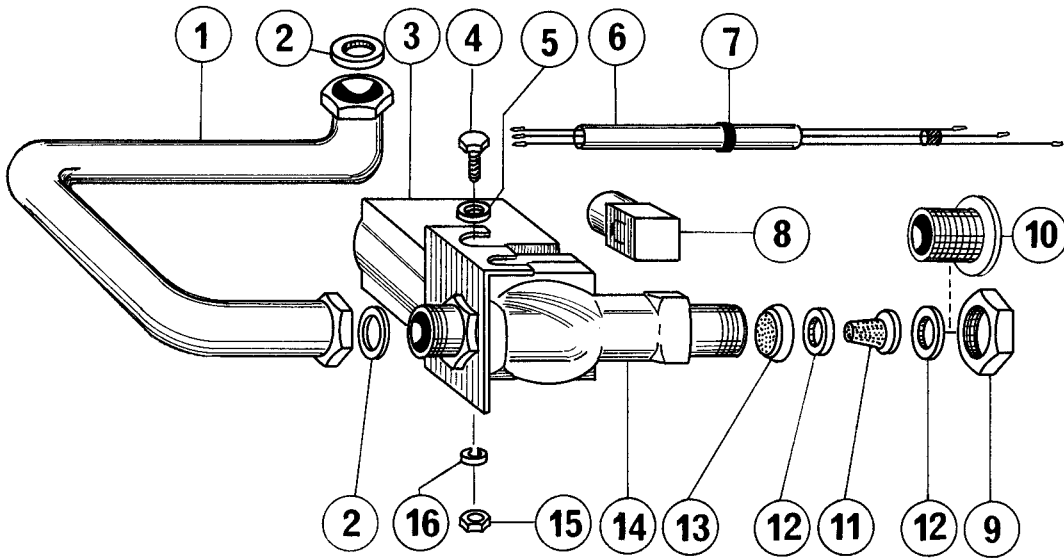

PLE 100 540

key no. réf. Pos. Nr.	part no. pièces no. Teile-Nr.	part name nom de la pièce Teile-Benennung	qty. qté. Stck.
1	228885	connecting pipe, assembly tuyauterie de liaison, ensemble Verbindungsleitung, komplett	1
2	168611-9	gasket joint Dichtung	1
3	228695-20*	coil bobine Spule 220/50	1
	228695-23*	coil bobine Spule 230-250/50	1
	228685-27*	coil bobine Spule 220-230/60	1
4	SCM-E-13-24	hexagon head screw, M 6 x 16 (s.st.) visH, M 6 - 16 (inox) Sechskantschraube DIN 933- M 6 x 16- A2	2
5	WAM-E-8-28	plain washer M 6 (s.st.) rondelle M 6 N (inox) Scheibe DIN 125-6.4-A2	1
6	228711	cable, assembly faisceau électrique, ensemble Kabelsortiment	1
7	227748-1	cable protecting sleeve gaine de cable Kabeldurchführungstülle	1
8	228905-2	plug fiche Stecker	1
9		union nut R3/4" écrou-raccord R 3/4" Überwurfmutter 4374-R 3/4" (not with rinse booster pump) (pas avec pompe elevatrice de pression) (nicht bei Drucksteigerungspumpe)	1
10		screwed socket piece filetee Einschraubteil 4372 18-G 3/4	1
11	227984	filter basket panierfiltre Korbfilter	1
12	165178	rubber gasket joint caoutchouc Gummidichtung	2
13	228895-1	flow control regulateur de debit Mengenregler (not with rinse booster pump) (pas avec pompe elevatrice de pression) (nicht bei Drucksteigerungspumpe)	1
14	228695-1*	solenoid valve with adaptor, assembly electrovanne avec piece de jonction, ensemble Magnetventil mit Anschlußstück, komplett 220150	1
	228695-2*	solenoid valve with adaptor, assembly electrovanne avec piece de jonction, ensemble Magnetventil mit Anschlußstück, komplett 220-250/50	1
	228695-3*	solenoid valve with adaptor, assembly electrovanne avec piece de jonction, ensemble Magnetventil mit Anschlußstück, komplett 220-230/60	1
15	NUM-E-3-2	hexagon nut, M 6 (s.st.) écrouH, M 6 (inox) Sechskantmutter DIN 934- M 6 - A 2	2
16	LWM-E-3-1	LWM-E-3-1, single coil lockwasher, M 6 (s.st.) rondelle WZ 6 (inox) Federring DIN 127 - B 6 - A2	2
	228695-40*	spare parts kit - solenoid valve kit pieces de rechange - electrovanne Ersatzteil-Set - Magnetventil	1
		indicate solenoid valve producer please s.v.p. indiquer les coordonnees du fabricant d'électrovannes bitte Magnetventil-Hersteller angeben	

+7(812)987-08-81

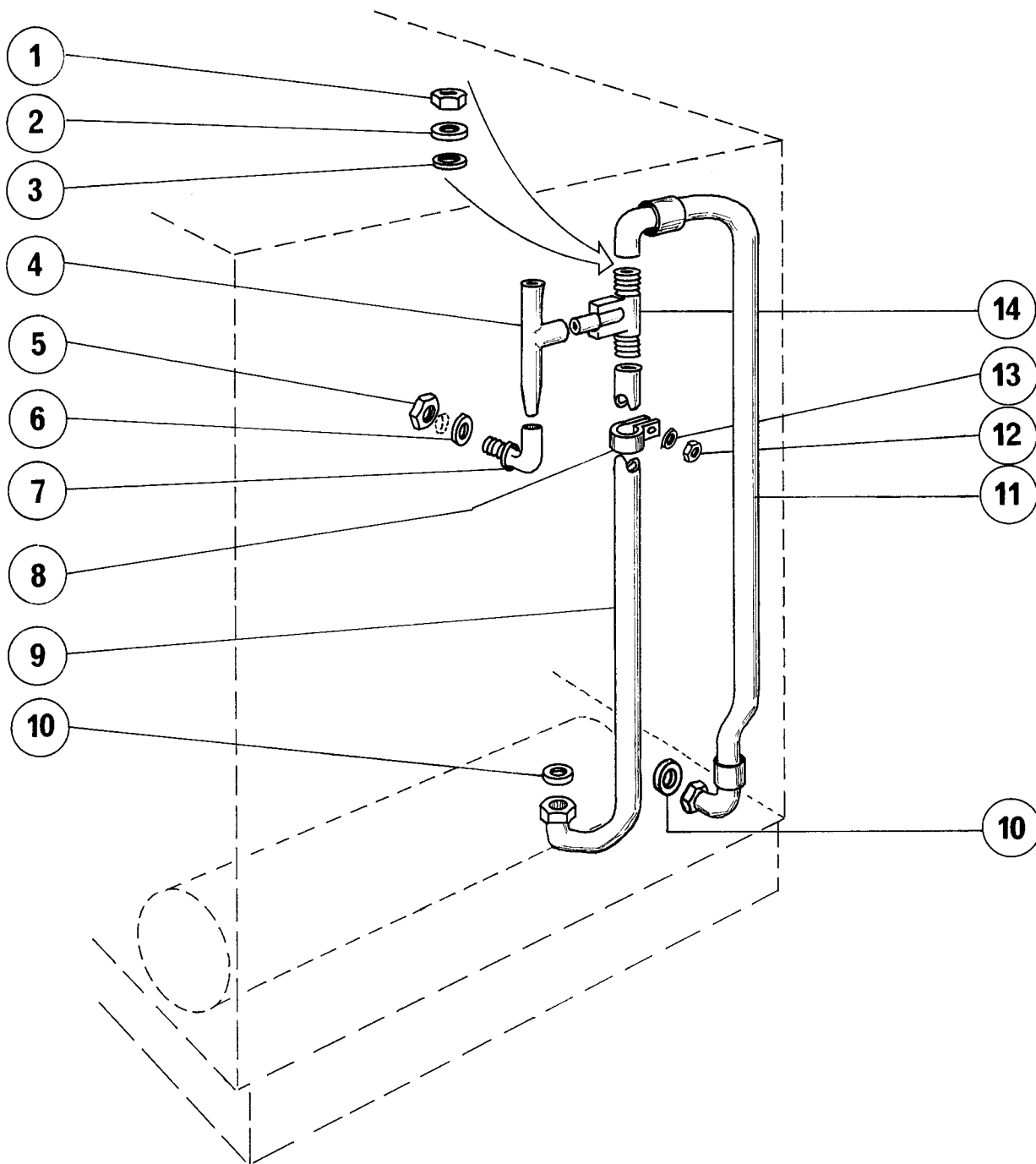

PLE 100 508

key no. ref. Pos. Nr.	part no. pieces no. Teile-Nr.	part name nom de la pièce Teile-Benennung	qty. qté. Stck.
1		union nut 4374 - R 5/8" ecrou 4374 - R 5/8" Überwurfmutter 4374-R 5/8"	2
2	228694-1	washer 20,5 x 18,1 x 0,5 rondelle 20,5 x 18,1 x 0,5 Scheibe 20,5 x 18,1 x 0,5	2
3	276903-4	"o"-ring 1 a x 1,3 joint torique 1 a x 1,3 O-Ring 18 x 1,3	2
4	228892	hose, assembly tuyau, ensemble Schlauch, komplett	1
5	172600	nut ecrou Mutter	1
6	172513	gasket joint Dichtung	1
7	166460	joining piece, filling raccord de remplissage Anschlußstück Füllung	1
8	228715-5	mounting bracket collier de fixation Befestigungsschelle	1
9	228699	booster heater pipe, assembly tuyauterie de la chaudière, ensemble Boilerleituna. kompl.	1
10	168611-9	gasket joint Dichtung	2
11	228696	pipe, assembly tuyauterie, ensemble Zuleitung, komplett	1
12	NUM-E-2-11	NUM-E-2-11, hexagon nut M 4 (s.st.) ecrou H, M 4 (inox) Sechskantmutter DIN 934 - M 4 - A 2	1
13	WAM-E-8-14	WAM-E-6-14, plain washer M 4(s.st.) rondelle M 4 N (inox) Scheibe DIN 125-4,3-A2	2
14	228541	anti-siphon-device (not required for U.K.) brise-vide (pas pour l'Angleterre) Rücksaugeverhinderer (nicht für England)	1

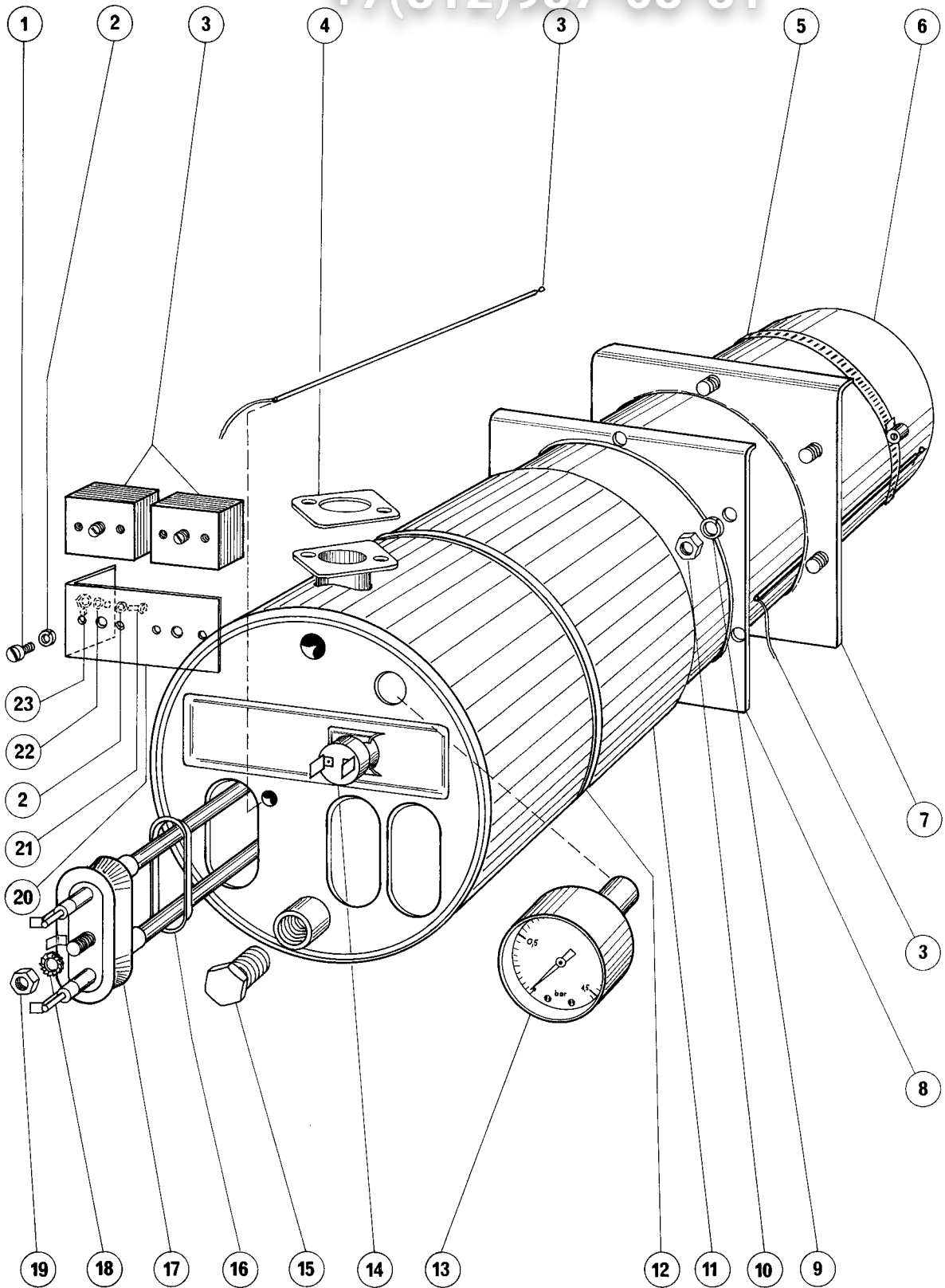

key no. réf. Pos. Nr.	part no. pièces no. Teile-Nr.	part name nom de la pièces Teile-Benhnung	qty. qté Stck.	
1	SCM-E-2-2	recessed raised cheese head screw M 4 x 8 (sst.) vis RM4-8 (inox) Linsenschraube M 4 x 8 DIN 7934 A2	4	
2	LWM-E-2-2	single coil lockwasher, M 4 (sst.) rondeile WZ4 (inox) Federring DIN 127 - B 4 - 1.4310	6	
3	B-226 505	thermostat thermostat Thermostat	2	
4	B-226 643	gasket joint Dichtuno	1	
5	166513-8	clamp-hose serre-tuyau Schlauchschelle	2	
6	228627	booster chaudiere Boiler	1	
7	228603	flange, assy. bride, ens. Flansch, kompl.	1	
8	228602	gasket joint Dichtung	1	
9	LWM-E-3-1	single coil lockwasher M 6 (s.st.) rondelle WZ6 (inox) Federring DIN 127 - B 6 - 1.4310	6	
10	NUM-E-3-2	hexagon nut M 6 (sst.) ecrou H M 6 (inox) Sechskantmutter DIN 934- M 6 - A2	6	
11	228750	insulation board plaque calorifugue Dammplatte	1	
12	169139-2	cable binder serre-cable Kabelbinder	3	
13	228632-1	pressure gauge manometre Manometer	1	
14	226504	temperature limiter limiteur de temperature Temoeraturbearenzer	1	
15	226989	plug-drain bouchon de ridange Blindstoofen	1	
16	166202	gasket-heating element joint de thermoplongeur Dichtuna fur Heizkörper	3	
17	228579-1	heating element (incl. items no16,18,19) thermoplongeur (compr. ref. 16,18,19) Rohrheizkorper (inkl. Teile Nr. 16,18,19)	2,5 kW 380/50/3 380/50/3/N	3
	228579-2	heating element (incl. items no16,18,19) thermoplongeur (compr. ref. 16,18,19) Rohrheizkorper (inkl. Teile Nr. 16,18,19)	2,5 kW 415/50/3 415/50/3/N	3
	228579-3	heating element (incl. items no16,18,19) thermoplongeur (compr. ref. 16,18,19) Rohrheizkorper (inkl. Teile Nr. 16,18,19)	2,5 kW 440/60/3	3
	227953-1	heating element (incl. items no16,18,19) thermoplongeur (compr. ref. 16,18,19) Rohrheizkorper (inkl. Teile Nr. 16,18,19)	2 kW 220/50/3 220/60/3	3
	227953-2	heating element (incl. items no16,18,19) thermoplongeur (compr. ref. 16,18,19) Rohrheizkorper (inkl. Teile Nr. 16,18,19)	2 kW 240/50/3	3
	165099-1	heating element (incl. items no16,18,19) thermoplongeur (compr. ref. 16,18,19) Rohrheizkorper (inkl. Teile Nr. 16,18,19)	1,5 kW 220/50/1 220/50/3 380/50/3 220/60/3 380/50/3/N	3
	165099-2	heating element (incl. items no18,18,19) thermoplongeur (compr. ref. 16,18,19) Rohrheizkorper (inkl. Teile Nr.16,18,19)	1,5 kw 240/50/1 240/50/3 415/50/3 415/50/3-N	3
	165099-3	heating element (incl. items no16,18,19) thermoplongeur (compr. ref. 16,18,19) Rohrheizkörper (inkl. Teile Nr.	1,5kW 440/60/3	3

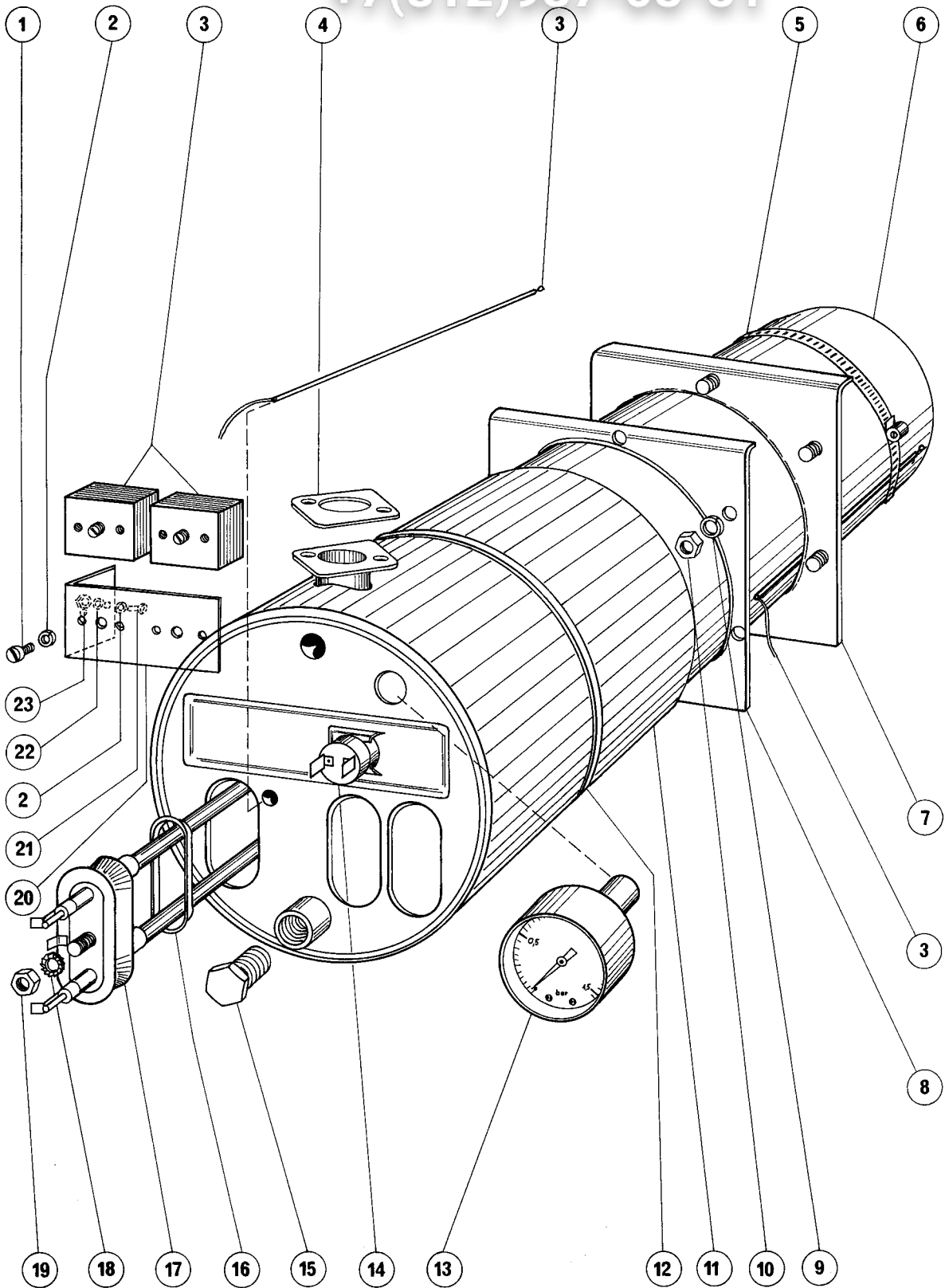

**Booster****Chaudière 7,5/6/4,5 kW****Boiler****FM-30****FM-30 U**

Зип Общепит

vsezip.ru

+7(812)987-08-81

key no. réf. Pos. Nr.	part no. pièces no. Teile-Nr.	part name nom de la pièce Teile-Benennung	qty. qté Stck.
16		toothed lockwasher M 6 rondelle DE 6 Zahnscheibe DIN 6797 -J 6,4	3
19	NUM-E-3-2	NUM-E-3-2, hexagon nut M 6 (sst.) ecrou H, M 6 (inox) Sechskantmutter DIN 934- M 6 - A2	3
20	228725	angle équerre Winked	1
21	SCM-E-11-7	SCM-E-I 1-7, recessed pan head screw M 4 x 10 (s.st.) vis RL, M 4 - 10 (inox) Linsenschraube DIN 7965 - M 4 x 10 - A2	2
22		washer rondelle Scheibe DIN 125 - 4,3 - A2	2
23	NUM-E-2-6	NUM-E-2-6, hexagon nut M 4 (s.st.) ecrou H, M 4 (inox) Sechskantmutter DIN 934- M 4 - A2	2
	228626-3	booster, assy. (incl. items no. 6,11-14,17) chaudiere, ens. (compr. ref.6,11-14,17) Boiler, kompl. (inkl. Teile Nr.6,11-14,17)	7,5 kW ~-\$!\$\$N 1
	228626-4	booster, assy. (incl. items no. 6,11-14,17) chaudiere, ens. (compr. ref.6,11-14,17) Boiler, kompl. (inkl. Teile Nr.6,11-14,17)	7,5 kW ii \$zz;&N 1
	228626-6	booster, assy. (incl. items no. 6,11-14,17) chaudiere, ens. (compr. ref.6,11-14,17) Boiler, kompl. (inkl. Teile Nr.6,11-14,17)	7,5 kW 440,60/3 1
	228626-7	booster, assy. (incl. items no. 6,11-14,17) chaudiere, ens. (compr. ref.6,11-14,17) Boiler, kompl. (inkl. Teile Nr.6,11-14,17)	6 kW 220/50/3 220/60/3 1
	228626-8	booster, assy. (incl. items no. 6,11-14,17) chaudiere, ens. (compr. ref.6,11-14,17) Boiler, kompl. (inkl. Teile Nr.6,11-14,17)	6 kW 240/50/3 1
	228626-1	booster, assy. (incl. items no.6,11-14,17) chaudiere, ens. (compr. ref.6,11-14,17) Boiler, kompl. (inkl. Teile Nr.6,11-14,17)	4,5 kW 220/50/1 220/50/3 380,50,3 220/60/3 380/50/3/N 1
	228626-2	booster, assy. (incl. items no. 6,11-14,17) chaudiere, ens. (compr. ref.6,11-14,17) Boiler, kompl. (inkl. Teile Nr. 6,11-14,17)	4,5 kW 240/50/1-3 415/50/3/N 1
	228626-5	booster, assy. (incl. items no.6,11-14,17) chaudiere, ens. (compr. ref.6,11-14,17) Boiler, kompl. (inkl. Teile Nr. 6, 11-14,17)	4,5 kW 440/60,3 1

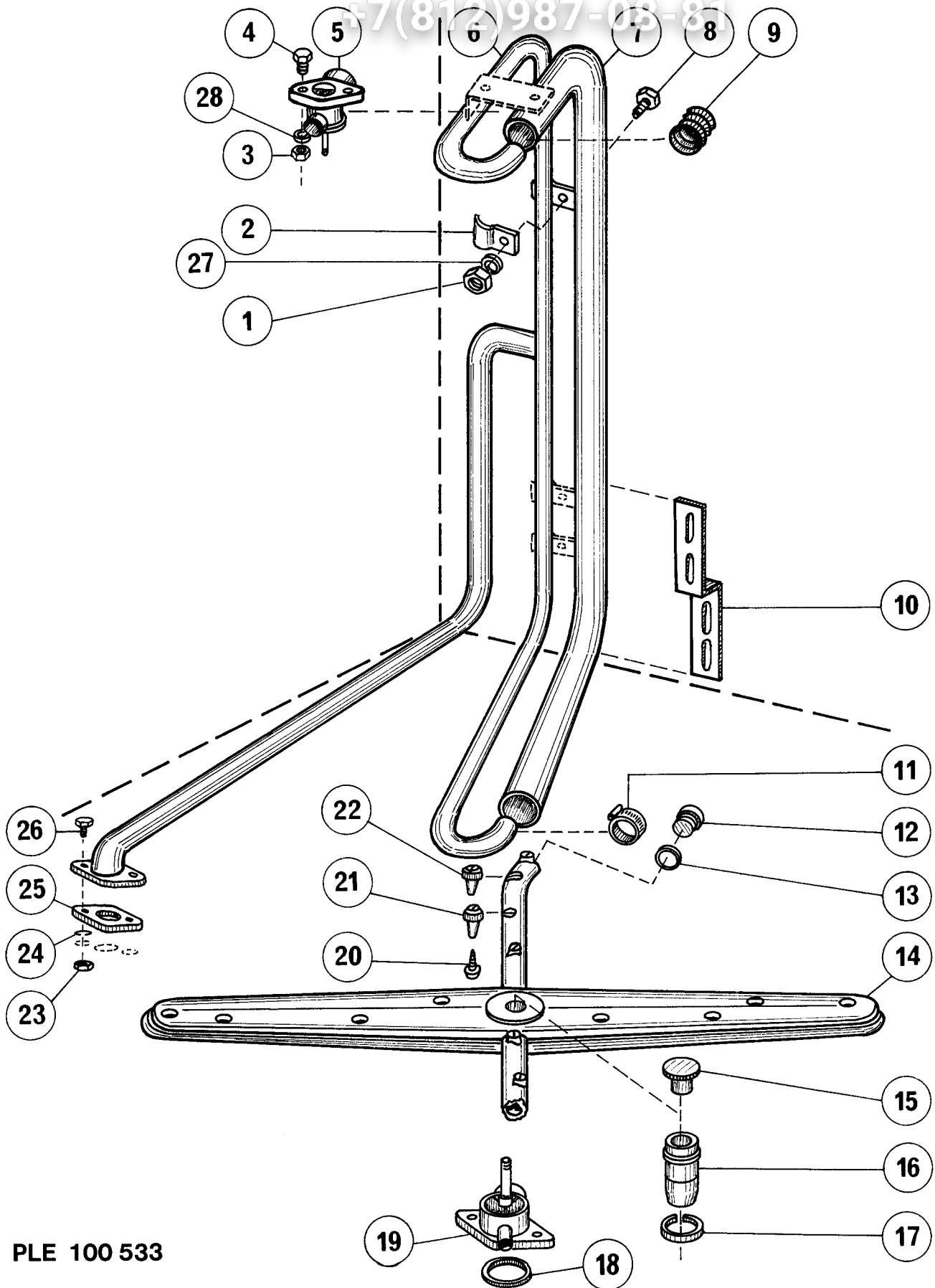

PLE 100 533



Wash and rinse system

Système de lavage et de rinçage

Wasch- und Spülsystem

FM-30

FM-30 U

vsezip.ru

(812)987-08-81

key no. réf. Pos. Nr.	part no. pièces no. Teil-Nr.	part name nom de la pièce Teil-Benennung	qty. - qté. - Stck.	
			FM-30	FM-30 U
1	NUM-E-2-30	NUM-E-2-30, hexagon nut, M 6 (s.st.) ecrou H, M 5 (inox) Sechskantmutter DIN 935-M5-A2	3	1
2	228642	pipe clamp bride de fixation Befestigungsschelle	3	1
3	226792	insert nut ecrou a insertion Einprel3mutter	2	2
4	SCM-E-13-20	SCM-E-I 3-20, hexagon head screw, M 6 x 12 (s.st.) vis H, M 6 - 12 (inox) Sechskantschraube DIN 933 - M 6 x 12 - A2	2	-
4	SCM-E-13-10	SCM-E-I 3-10, pan head screw, M 6 x 12 (s.st.) vis RL M 6 - 12 (inox) Becherschraube M 6 x 12 - A2	-	2
5	228536	upper tee support du tourniquet, superieure Dreharmbasis. oben	1	1
6	228862	rinse pipe, assembly tuyauterie de rincage, ensemble Spulleitung, komplett	1	-
6	228638	rinse pipe, assembly tuyauterie de rincage, ensemble Spulleitung, komplett		1
7	228860	wash pipe, assembly conduit de lavage, ensemble Waschrohr, komplett	1	-
7	228641	wash pipe, assembly conduit de lavage, ensemble Waschrohr, komplett	-	1
8	SCM-E-12-4	SCM-E-I 2-4, hexagon head screw, M 5 x 10 (s.st.) vis H, M5-IO (inox) Sechskantschraube DIN 933 - M 5 x 10 - A2	3	1
9	228624	gasket joint Dichtung	2	2
10	228859	bracket support Halterung	1	-
11	166513-7	hose clamp collier Schlauchschelle	2	2
12	226816	end cap bouchon Stoofen	2	2
13	67500-30	"O"-ring joint torique O-Ring	2	2
14	228589	wash and rinse arm bras de lavage et de rincage Wasch- und Spülarm	1	1
15	228644	knurled nut ecrou moleté Randelmutter	1	1
16	228643	bush manchette Btichse	1	1
17		snap ring jonc Sprengring DIN 7993-A14-1.4310	1	1
18	67500-37	"O"-ring joint torique O-Ring	1	1
19	228535	lower tee support du tourniquet, inferieure Dreharmbasis, unten	1	1
20	SD-E-1-32	self tapping screw, no 8 x 9,5 (s.st.) vis auto-taraudeuse, SP 11 8-9,5 (inox) Blechschrabe DIN 7981 - B 4,2 x 9,5 - A2	9	9
21	226800-2	nozzle, dark grey jet, gris fence D&se, dunkelgrau	5	5

vsezip.ru

7(812)987-08-81

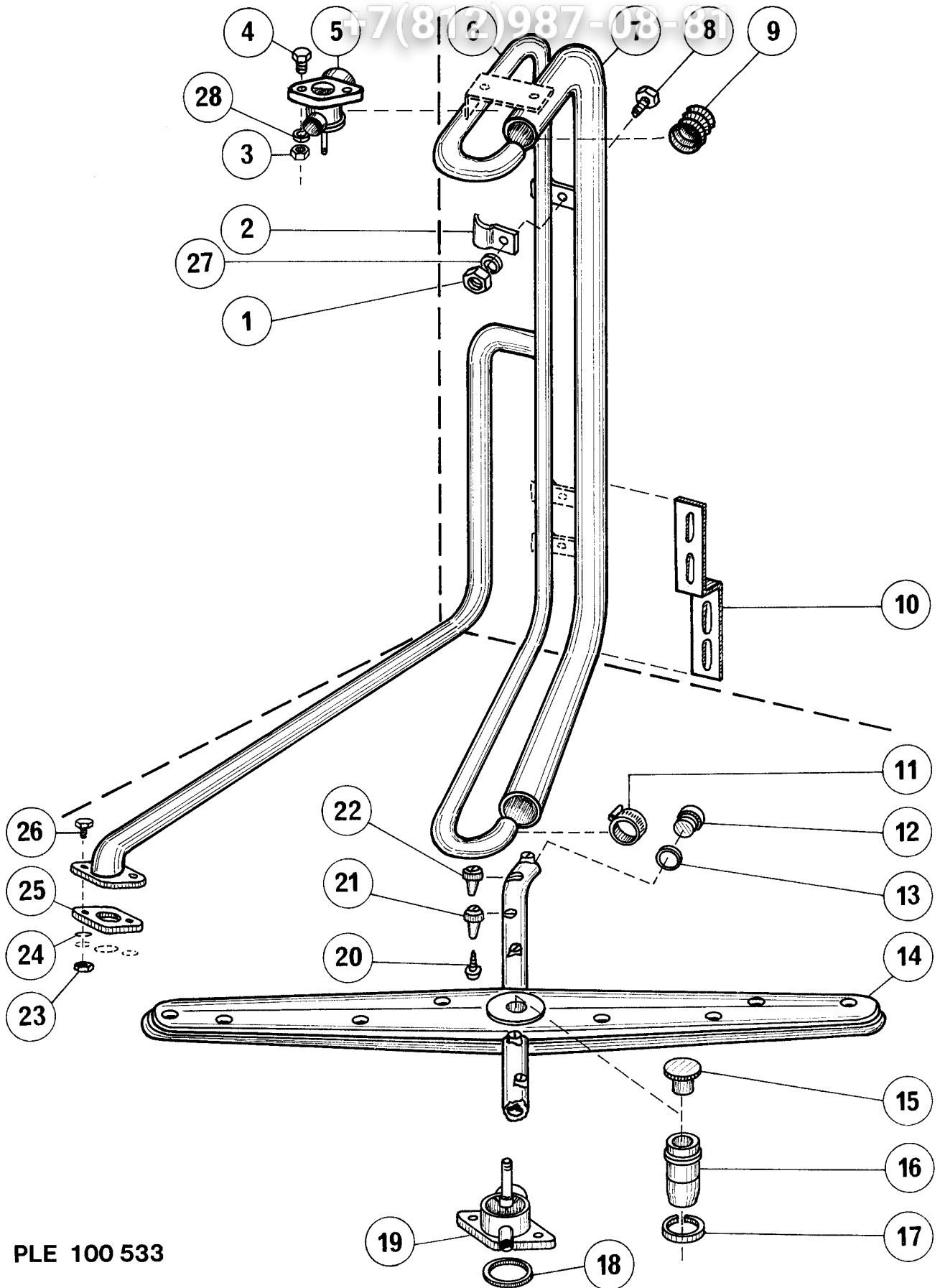

PLE 100 533

key no. réf. Pos. Nr.	part no. pièces no. Teile-Nr.	part name nom de la pièce Teile-Benennung	qty. - qté - Stck.	
			FM-30	FM-30 U
22	226800-1	nozzle, light grey jet, gris clair Dime. heliarau	4	4
23	NUM-E-3-27	NUM-E-3-27, hexagon nut, M 8 (s.st.) ecrou H, M 8 (inox) Sechskantmutter DIN 934 - M 8 - A2	2	2
24	LWM-E-3-27	LWM-E-3-27, single coil lockwasher, M 8 (s.st.) rondelle WZ8 (inox) Federring DIN 127-B8-1.4310	2	2
25	226643	gasket joint Dichtung	1	1
26	SCM-E-14-15	SCM-E-1 4-15, hexagon head screw, M 8 x 20 (sst.) vis H, M 8 - 20 (inox) Sechskantschraube DIN 933-M8x20-A2	2	2
27	LWM-E-2-28	LWM-E-2-28, lockwasher M 5 (s.st.) rondelle WZ.5 (inox) Federring DIN 127 - B 5 - 1.4310	3	1
28	LWM-E-3-1	LWM-E-3-1, lockwasher M 6 (s.st.) rondelle WZ6 (inox) Federrina DIN 127 - B 6 - 1.4310	2	-
	228867	wash and rinse pipe, assembly (incl. items 1-3,5-11,19) conduit de lavage et de rincage, ensemble (compr. ref. 1-3,5-11,19) Wasch- und Sotilleituna. komolett (inkl. Teile 1-3.511,19)	1	-
	228636	wash and rinse pipe, assembly (incl. items 1-3,5-9,11,19) conduit de lavage et de rincage, ensemble (compr. ref. 1-3,5-9,11,19) Wasch- und .%i_illeituna. komolett (inkl. Teile 1-3.5-9.11.19)	-	1
	228567	wash and rinse arm, assembly (incl. items 12-17,20-22) bras de lavage et de rincage, ensemble (campr. ref. 12-17,20-22) Wasch- und Soualarm. komolett (inkl. Teile 12-17.20-22)	2	2

+7(812)987-08-81

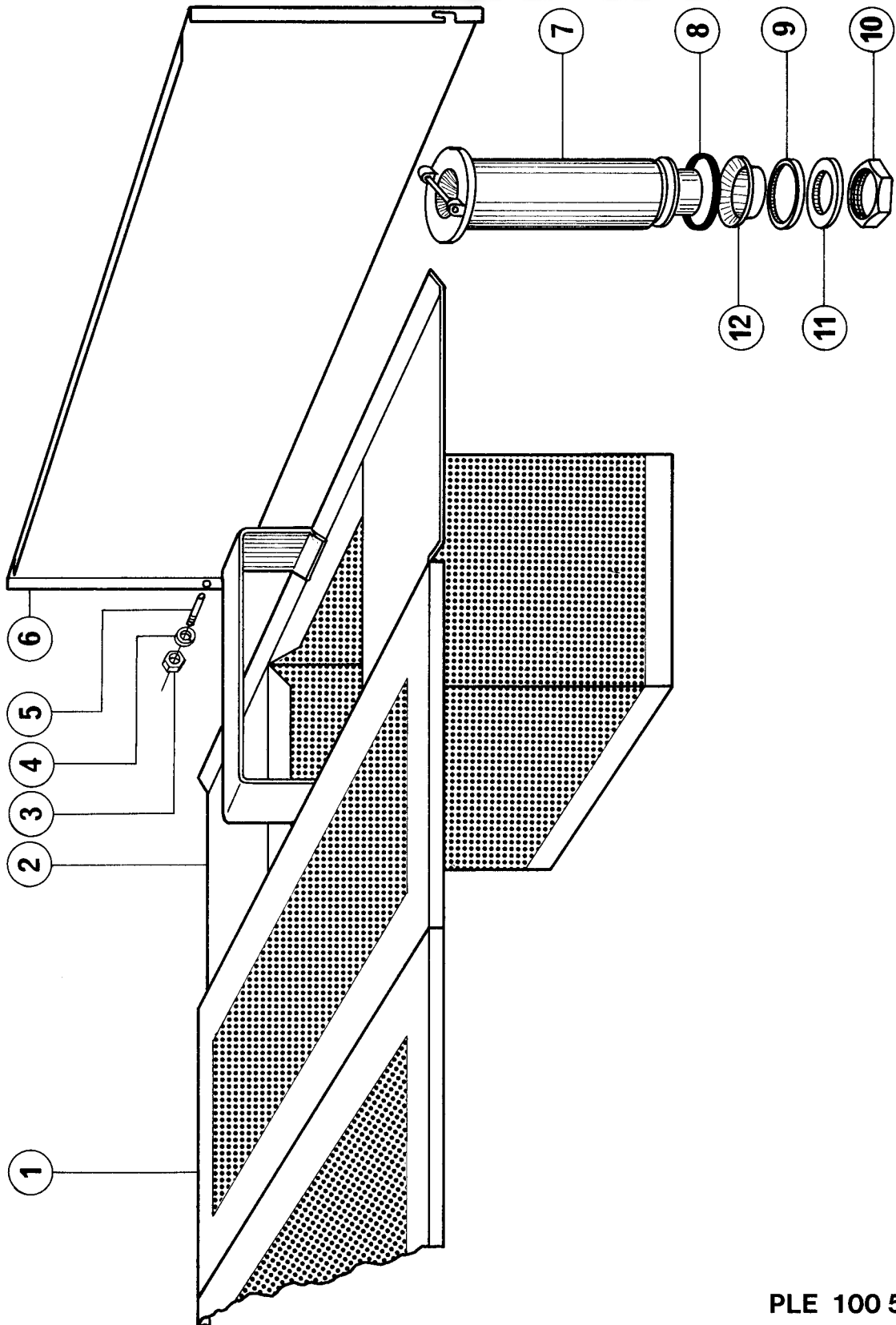

PLE 100 541

key no. ref. Pos. Nr.	part no. pieces no. Teile-Nr.	part name nom de la piece Teile-Benennung	qty. qté. Stck.
1	228645	strainer filtre Sieb	2
2	228646	strainer basket, assembly panier-filtre, ensemble Siebkorb, komplett	1
3	NUM-E-2-30	NUM-E-2-30, hexagon nut, M 5 (s.st.) écrou H, M 5 (inox) Sechskantmutter DIN 934 - M 5 - A2	1
4	LWM-E-2-28	LWM-E-2-28, single coil lockwasher, M 5 (s.st.) rondelle WZ5 (inox) Federrino DIN 127 - B 5 - 1.4310	1
5	228684	pintle pivot Drehbolzen	1
6	228793	hinged cover couvercle rabattant Abdeckklaooe	1
7	228600	overflow pipe tube de vidange Überlaufrohr	1
8	67500-15	"o"-ring joint torique O-Ring	1
9	226556	gasket joint Dichtung	1
10	226557	back nut contre-écrou Gegenmutter	(FM-30 U: not with drain pump) (FM-30 U: pas avec pompe de vidange) (FM-30 U: nicht bei Ablaufpumpe)
11	21104	washer rondelle Scheibe	1
12	226558	drain funnel entonnoire de vidange Ablaufstutzen	(FM-30 U: not with drain pump) (FM-30 U: pas avec pompe de vidange) (FM-30 U: nicht bei Ablaufpumpe)

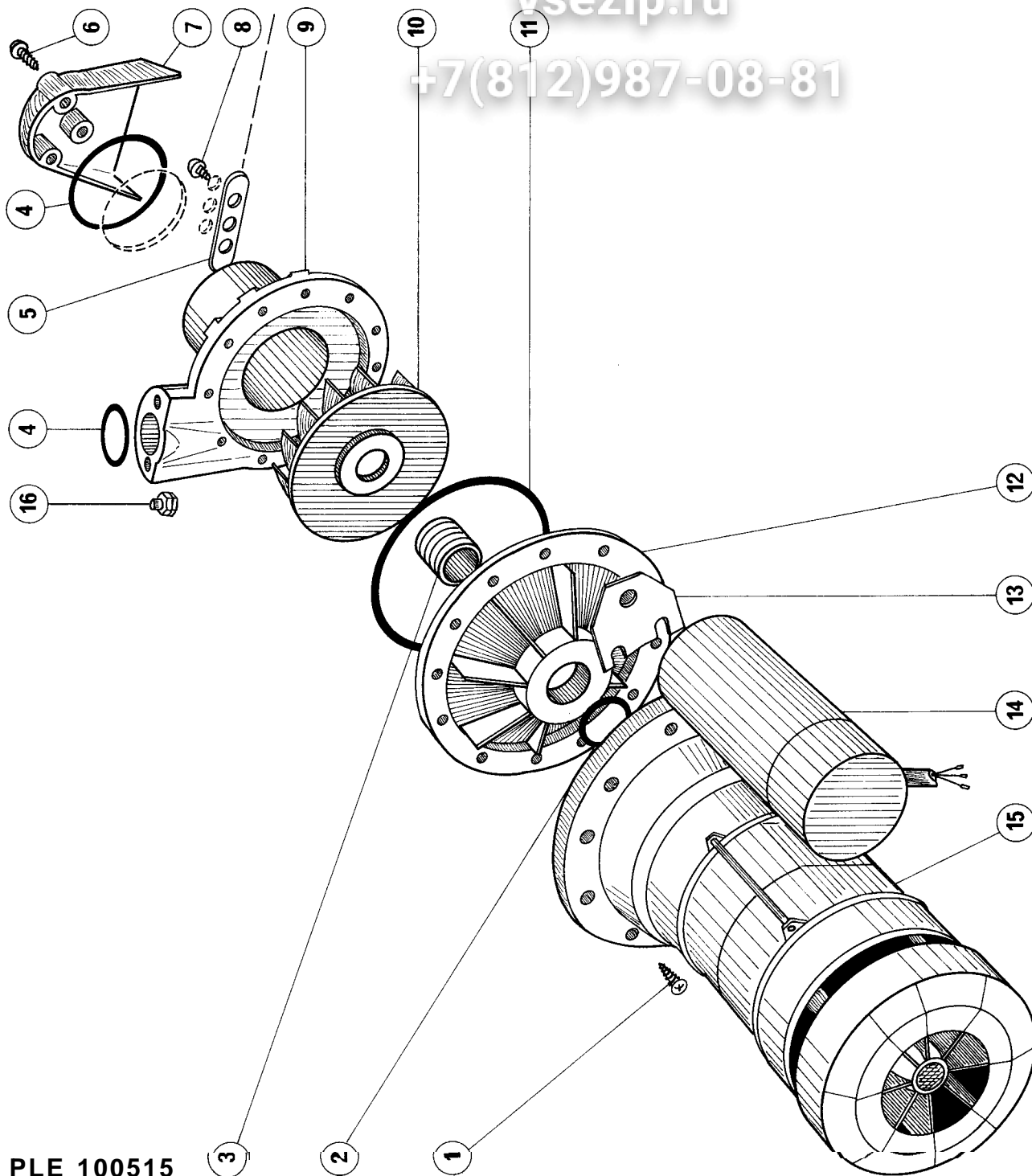

PLE 100515

key no. réf. Pos. Nr.	part no. pièces no. Teile-Nr.	part name nom de la pièce Teile-Benennung	qty. qté. Stck.
1	SD-32-14	self-tapping screw 4,8 x 25 vis auto-taraudeuse 4,8 x 25 Blechschaube BZ 4,8 x 25	11
2	67500-8	"o"-ring joint torique O-Ring	1
3	104329	shaft seal joint rotatif Gleitringdichtung	1
4	67500-57	"o"-ring joint torique O-Ring	2

key no. réf. Pos. Nr.	part no. pièces no. Teile-Nr.	part name nom de la pièce Teile-Benennung	qty. qté. Stck.
5	226791	gasket joint Dichtung	1
6	SD-E-1-38	self-tapping screw 4,8 x 50 (s.st.) vis auto-taraudeuse 4,8 x 50 (inox) Blehschraube DIN 7982 - B 4,8 x 50 - A2	3
7	226777	cover couvercle Abdeckung	1
8		self-tapping screw 4,8 x 16 (s.st.) vis auto-taraudeuse 4,8 x 16 (inox) Blehschraube DIN 7981 - B 4,8 x 16 - A2	2
9	226773	pump shell corps de pompe Spiralgehäuse	1
10	226775-2	impeller turbine Laufgrad	220-415/50/1-3/N 1
	226775-3	impeller turbine Laufgrad	220-240/60/3 1
11	276903-5	"o"-ring joint torique O-Ring	1
12	226774	cover couvercle Deckel	1
13	228891	bracket support Halterung	1
14	232210-1	condenser condensateur Kondensator	only/seulement/nur 220-240/50/1 1
15	228475-3	motor moteur Motor	220/50/1 1
	228475-4	motor moteur Motor	240/50/1 1
	228475-1	motor moteur Motor	220-380/50/3/N 1
	228475-2	motor moteur Motor	240-415/50/3/N 1
	228475-5	motor moteur Motor	440/60/3 1
	228475-6	motor moteur Motor	220/60/3 1
16	226792	insert nut ecrou a insertion Einpreßmutter	2
	226776-1	wash pump, assembly pompe de lavage, ensemble Waschpumpe, komplett	220/50/1 1
	226776-2	wash pump, assembly pompe de lavage, ensemble Waschpumpe, komplett	240/50/1 1
	226776-3	wash pump, assembly pompe de lavage, ensemble Waschpumpe, komplett	220-380/50/3/N 1
	226776-4	wash pump, assembly pompe de lavage, ensemble Waschpumpe, komplett	240-415/50/3/N 1
	226776-5	wash pump, assembly pompe de lavage, ensemble Waschpumpe, komplett	440/60/3 1
	226776-6	wash pump, assembly pompe de lavage, ensemble Waschpumpe, komplett	220/60/3 1

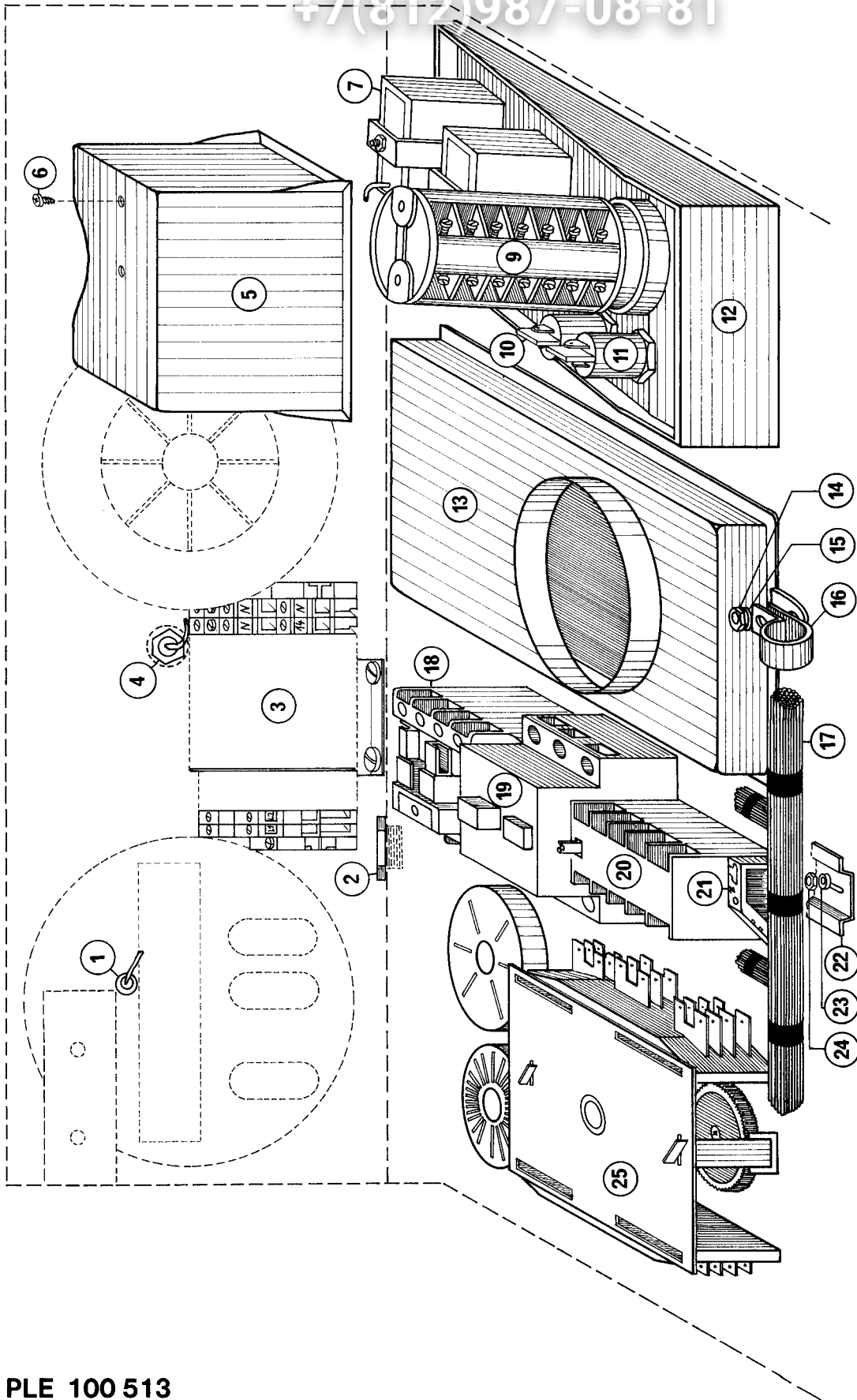

PLE 100 513

key no. réf. Pos. Nr.	part no. pièces no. Teile-Nr.	part name nom de la pièce Teile-Benennung	qty. qté. Stck.
1	227024-2	universal stuffing box douille de fixation Universalstopfbüchse	1
	168611-10	gasket joint Dichtuna	1
2	226931-2	bushing raccord Pg-Verschraubung	1
3	228887-1	terminal board, assembly ensemble des bornes et support 380-415/50/3/N Klemmenanordnung, komplett	1
	228887-2	terminal board, assembly ensemble des bornes et support 220-415/50/3; 220-440/60/3 Klemmenanordnung, komplett	1
	228888	terminal board, assembly ensemble des bornes et support 220-240/50/1 Klemmenanordnung, komplett	1
4	228721 PF-E-18-48	Nut protective covering for thermometer boîtier de protection du thermometre Thermometer-Schutzhülse	1
	168611-9	gasket joint Dichtung	1
		hexagon nut, 3/8" ecrou H, 3/8" Sechskantmutter DIN 431-3/8"	1
5	228743	cover couverture Abdeckung	1
6	SD-10-11	self-tapping screw #6-32 x 3/8" phil. truss head, type D visa tôle BL, à empreinte cruciforme 3,5 x 10 Flachrund-Blechschräube 3,5 x 10	2
7	228720-1	thermometer thermometre Thermometer	2
9	228719-1	cam switch interrupteur a cames Nockenschalter	1
10	227948-1	pilot lamp, white voyant lumineux, blanc Signalleuchte, weiß	1
11	227948-4	pilot lamp, green voyant lumineux, vert Signalleuchte, grün	1
12	228621-1	control panel enjoliveur Armaturenblende	1
	228621-2	control panel, FM-30 U (with drain pump) enjoliveur, FM-30 U (avec pompe de vidange) Armaturenblende, FM-30 U (mit Ablaufpumpe)	1
13	228753	cover couverture Abdeckung	1
14	NUM-E-2-6	NUM-E-2-6, hexagon nut M 4 (s.st.) ecrou H, M 4 (inox) Sechskantmutter DIN 934 - M 4 - A2	4
15	WAM-E-8-14	WAM-E-8-14, plain washer M 4 (s.st.) rondelle M 4 N (inox) Scheibe DIN 125 - 4,3 - A2	4
16	228715-4	pipe clamp bride de fixation Befestigungsschelle	2
17	228737	cable, assembly faisceau électrique, ensemble 220-440/50-60/3/N Leitungssortiment	1
	228883	cable, assembly faisceau électrique, ensemble 220-240/50/1 Leitungssortiment	1
18	40651-9	contactor contacteur 220-440/50-60/1-3/N Schütz	1

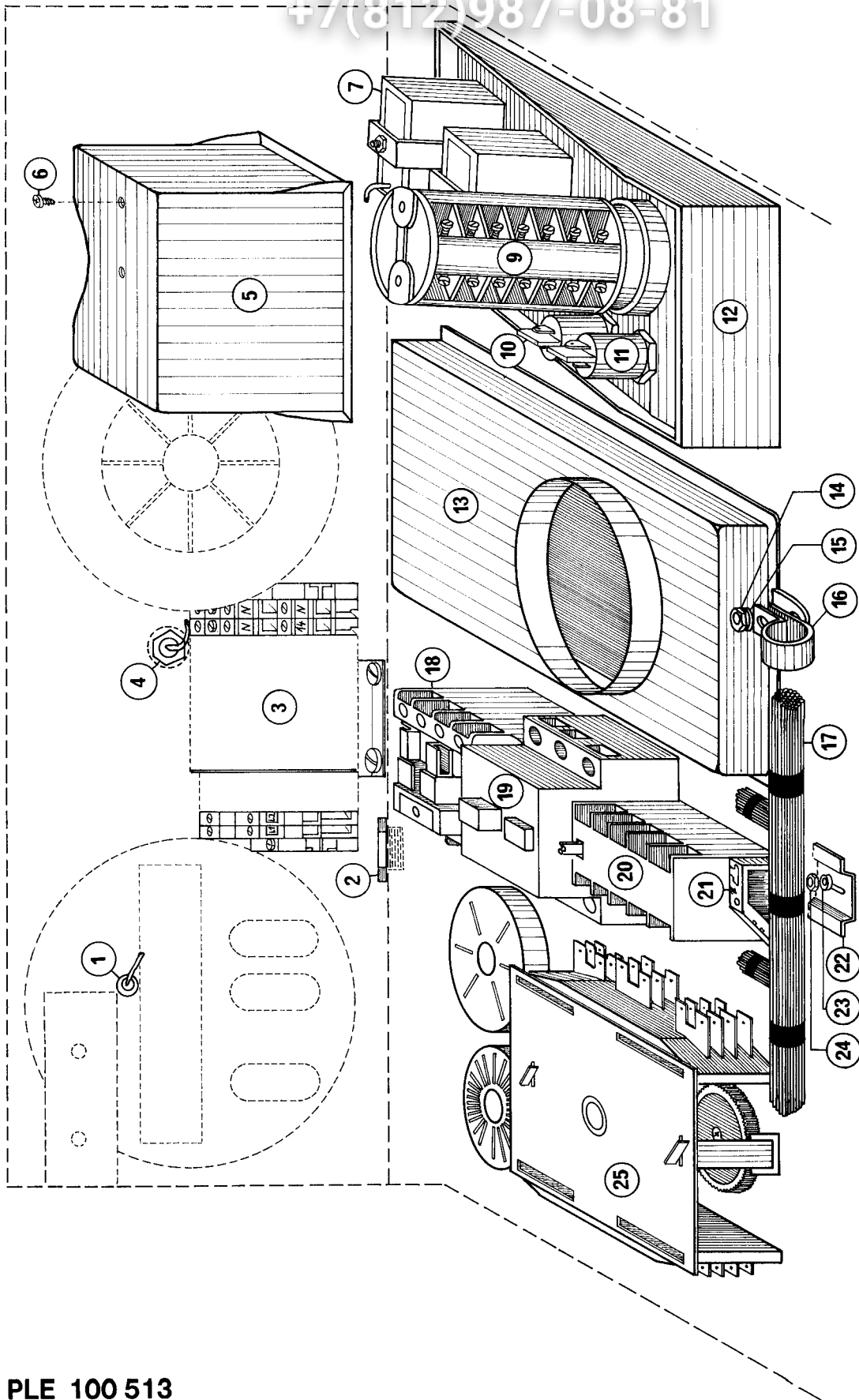

PLE 100 513

key no. ref. Pos. Nr.	part no. pieces no. Teile-Nr.	part name nom de la piece Teile-Benennung		qty. qté. Stck.
	40651-10	contactor contacteur Schütz	240-415/50/1-3/N	1
19	228717-3	thermal overload relay relais thermique Motorschutzschalter	220-240/50/ 1	1
	228717-2	thermal overload relay relais thermique Motorschutzschalter	220-240/50-60/3	1
	228717-1	thermal overload relay relais thermique Motorschutzschalter	380-440/50-60/3/N	1
20	228015-9	contactor contacteur Schütz	220-380/50/1-3/N	1
	228015-10	contactor contacteur Schütz	240-415/50/1-3/N	1
	228015-11	contactor contacteur Schütz	220-240/60/3	1
21	228428	end stop presse-borne Endwinkel		2
22	135919-11	mounting rail rail de montage Tragschiene		1
23	WAM-E-8-14	WAM-E-8-14, plain washer M 4 (s.st.) rondelle M 4 N (inox) Scheibe DIN 125 - 4,3 - A2		5
24	NUM-E-2-6	NUM-E-2-6, hexagon nut, M 4 (s.st.) ecrou H, M 4 (inox) Sechskantmutter DIN 934 - M 4 - A 2		8
25	228623-1	program timer programmateur Programmschaltwerk	220-440/50-60/1-3/N	1

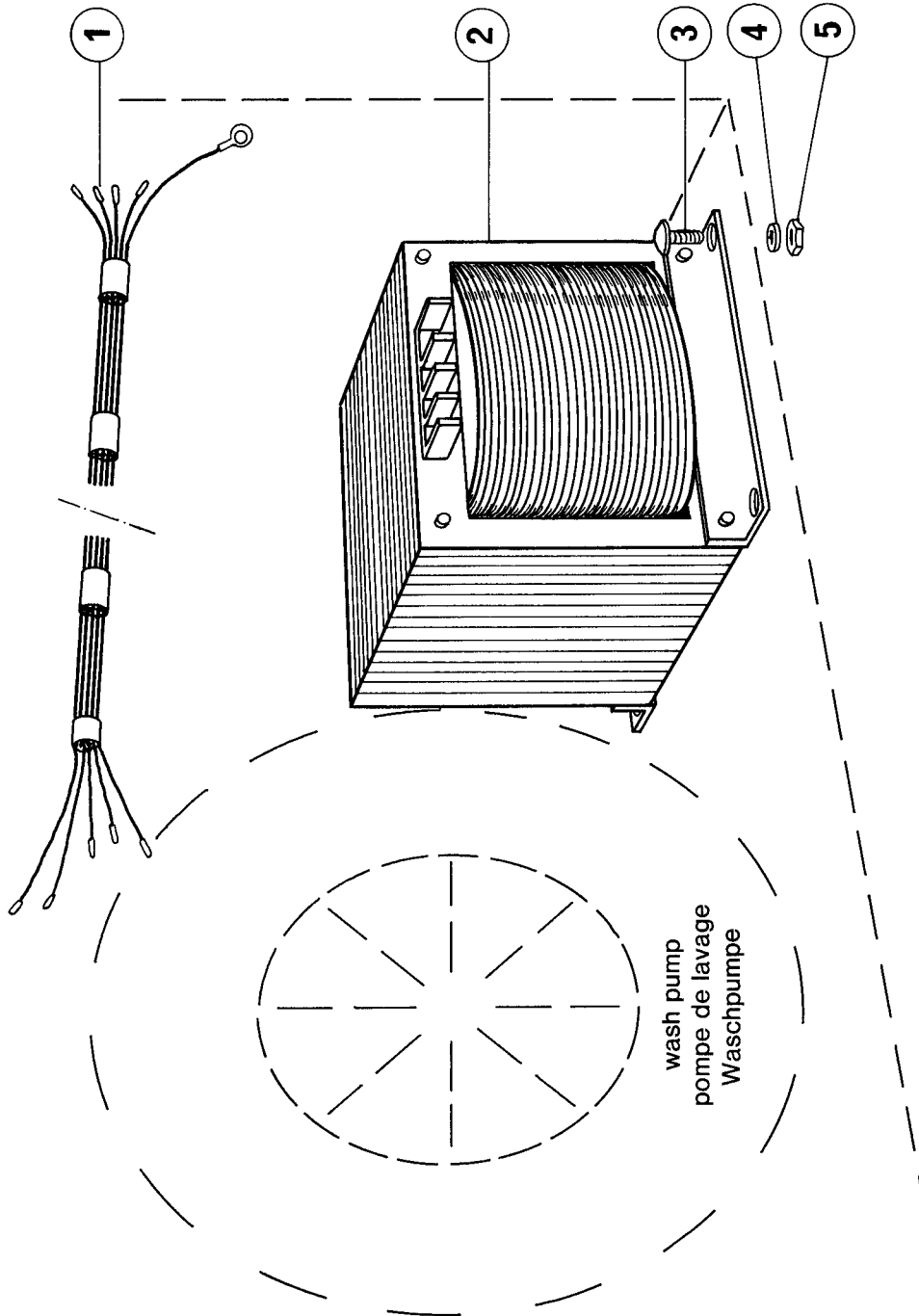

key no. réf. Pos. Nr.	part no. pièces no. Teile-Nr.	part name nom de la pièce Teile-Benennung	qty. qté. Stck.
1	228754	cable assembly faisceau de cables, ensemble Leitunassortiment	1
2	167231-1	transformer transformateur 380-415/50/3 Transformator	1
	167231-6	transformer transformateur 440/60/3 Transformator	1
3	SCM-E-11-8	SCM-E-11-8, screw truss head, M 4 x 10 (s.st.) vis CL, M 4 - 10 (inox) Linsenschraube DIN 7985 - M 4 x 10 - A2	2
4	LWM-E-2-2	LWM-E-2-2, lockwasher, M 4 (s.st.) rondelle WZ4 (inox) Federring DIN 127 - B4 - 1.4310	2
5	NUM-E-2-6	NUM-E-2-6, hexagon nut, M 4 (s.st.) ecrou H, M 6 (inox) Sechskantmutter DIN 934 - M4 - A2	2

vsezip.ru

+7(812)987-08-81

vsezip.ru

+7(812)987-08-81

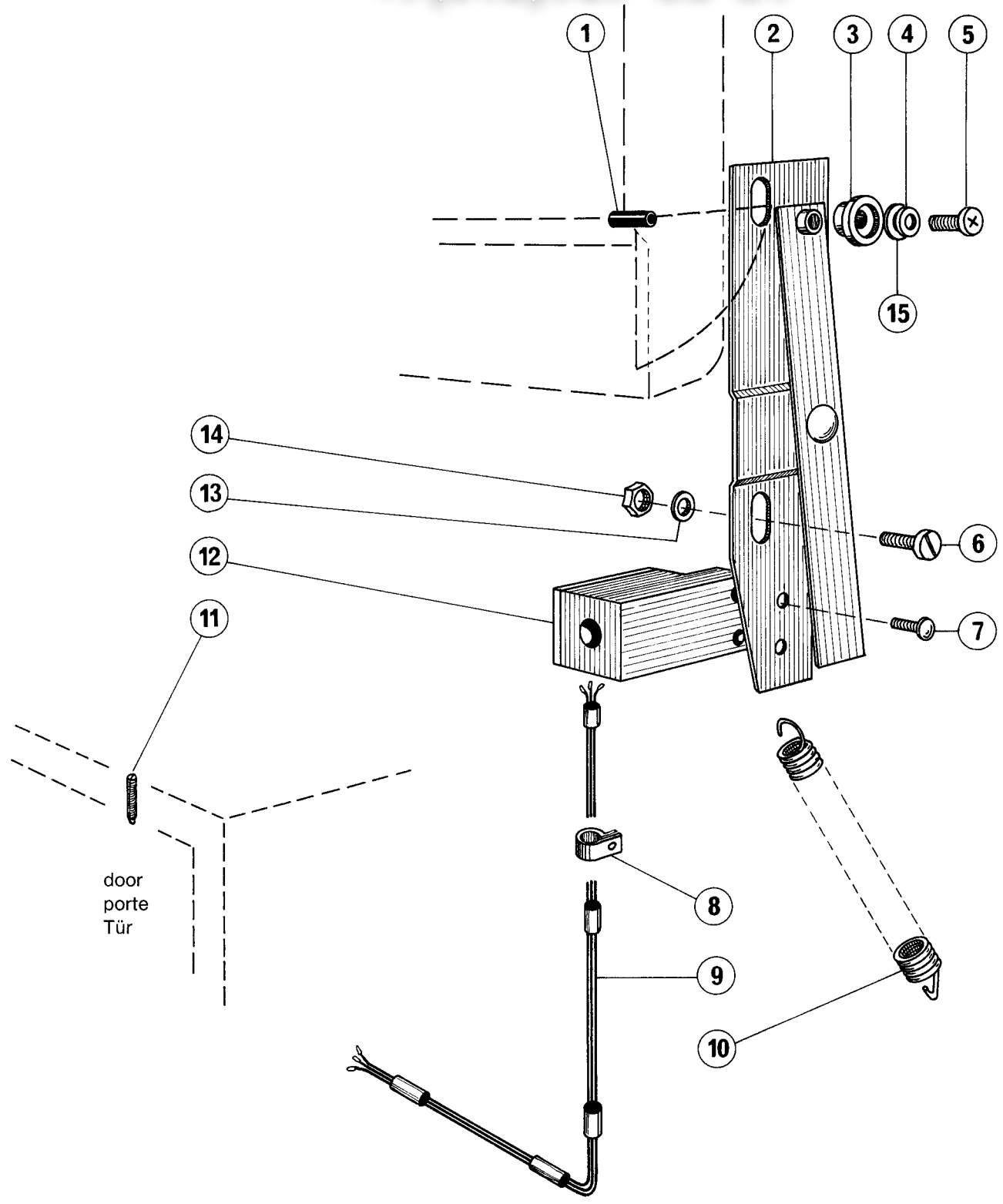

PLE 100 545

key no. ref. Pos. Nr.	part no. pièces no. Teile-Nr.	part name nom de la pièce Teile-Benennung	qty. qté. Stck.
1	228693-1	gasket joint Dichtuna	2
2	228677	end-switch mechanism, assembly mecanisme d'interrupteur, ensemble Türschalter-Mechanismus. komolett	1
3	116008	roller poulie Rolle	1
4	WAM-E-8-20	WAM-E-8-20, plain washer M 5 (s.st.) rondelle M5N (inox) Scheibe DINI25-A5,3-A2	1
5	SC-69-10	Mach. screw - no 8-32 x ,250 lg vis machine Maschinenschraube	1
6	SCM-E-12-4	SCM-E-I 2-4, pan head screw, M 5 x 10 (s.st.) vis RL, M 5 - 10 (inox) Flachkopfschraube DIN 85 - M 5 x 10 - A2	2
7	SCM-E-11-8	SCM-E-I 1-8, slotted raised cheese head screw, M 4 x 10 (s.st.) vis CB, M 4 - 10 (inox) Linsenschraube DIN 7985 - M 4 x 10 - A2	3
8	228715-1	fixing clamp bride de fixation Befestigungsschelle	1
9	228663	cable, assembly faisceau Leitungssortiment	1
10	227855	door spring ressort de Porte Türfeder	2
11	228619-1	friction catch vis de pression Federndes Druckstück	1
12	228718	end switch intérrupteur fin-de-course Endschalter	1
13	LWM-E-2-28	LWM-E-2-28, single coil lockwasher, M 5 (s.st.) rondelle WZ5 (inox) Federrina DIN 127 - B 5 - 1.4310	2
14	NUM-E-2-30	NUM-E-2-30, hexagon nut, M 5 (s.st.) ecrou H, M 5 (inox) Sechskantmutter DIN 934 - M 5 A2	2
15	WS-17-28	washer rondelle Scheibe	1

vsezip.ru

+7(812)987-08-81

+7(812)987-08-81

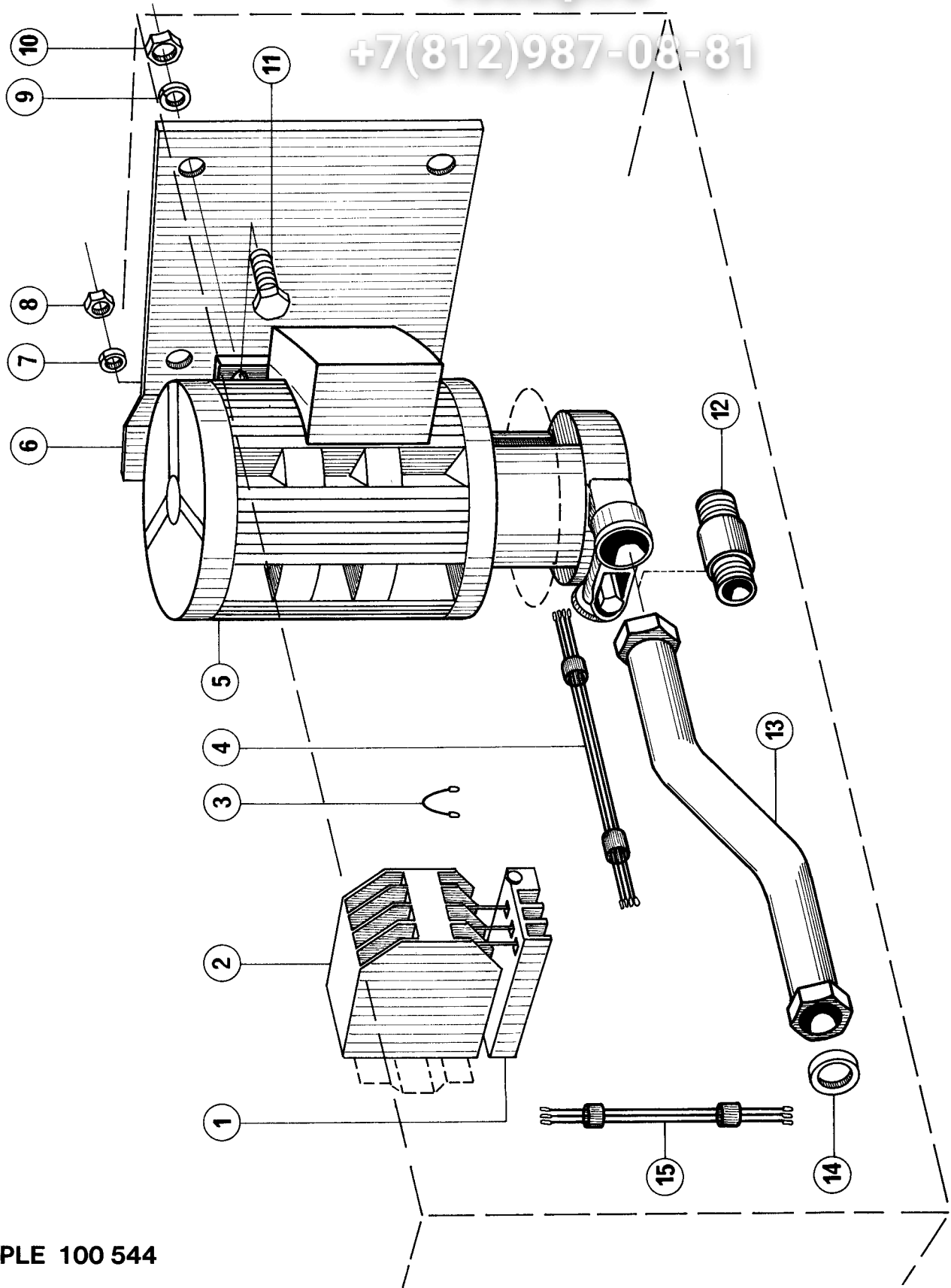

PLE 100 544

key no. réf. Pos. Nr.	part no. pièces no. Teile-Nr.	part name nom de la pièce Teile-Benennung	qty. qté. Stck.
1	B-56 731-4	thermal overload relay relais thermique Motorschutzrelais	380-440/50-60/3/N 1

key no. réf. Pos. Nr.	part no. pièces no. Teile-Nr.	part name nom de la pièce Teile-Benennung	qty. qté. Stck.
	56731-9	thermal overload relay relais thermique Motorschutzrelais	1
2	168988-1	contactor contacteur Schütz	1
	168988-2	contactor contacteur Schütz	1
	168988-3	contactor contacteur Schütz	1
3	227073-35	bridge pont Brücke	2
4	228740	cable assembly faisceau Leitungssortiment	1
	228739	cable assembly faisceau Leitungssortiment	1
5	228738-1	rinse booster pump pompe elevatrice depression Drucksteigerungspumpe	1
	228738-2	rinse booster pump pompe elevatrice depression Drucksteigerungspumpe	1
	228738-3	rinse booster pump pompe elevatrice depression Drucksteigerungspumpe	1
	228738-4	rinse booster pump pompe elevatrice depression Drucksteigerungspumpe	1
	228738-5	rinse booster pump pompe elevatrice depression Drucksteigerungspumpe	1
	228738-6	rinse booster pump pompe elevatrice depression Drucksteigerungspumpe	1
6	228722	bracket-rinse booster pump support - pompe elevatrice de pression Halterung - Drucksteigerungspumpe	1
7	LWM-E-3-27	LWM-E-3-27, single coil lockwasher, M 8 (s.st.) rondelle WZ 8 (inox) Federring DIN 127 - B 8 - 1.4310	2
8	NUM-E-3-27	NUM-E-3-27, hexagon nut, M 8 (s.st.) ecrou H, M 8 (inox) Sechskantmutter DIN 934 - M 8 - A2	2
9	LWM-E-3-1	LWM-E-3-1, single coil lockwasher, M 6 (s.st.) rondelle WZ6 (inox) Federring DIN 127 - B 6 - 1.4310	4
10	NUM-E-3-2	NUM-E-3-2, hexagon nut, M 6 (s.st.) ecrou H, M 6 (inox) Sechskantmutter DIN 934 - M 6 - A 2	4
11	SCM-E-13-24	SCM-E-13-24, hexagon head screw, M 6 x 16 (s.st.) vis H, M 6 - 16 (inox) Sechskantschraube DIN 933 - M 6 x 16 - A2	4
12	228741-1	nipple mamelon Nippel	1
13	228745	connecting pipe, assembly tuyauterie de liaison, ensemble Verbindungsleitung, komplett	1
14	168611-9	gasket joint Dichtung	1
15	228870	cable assembly faisceau Leitungssortiment	1
	228816	cable assembly faisceau Leitungssortiment	1

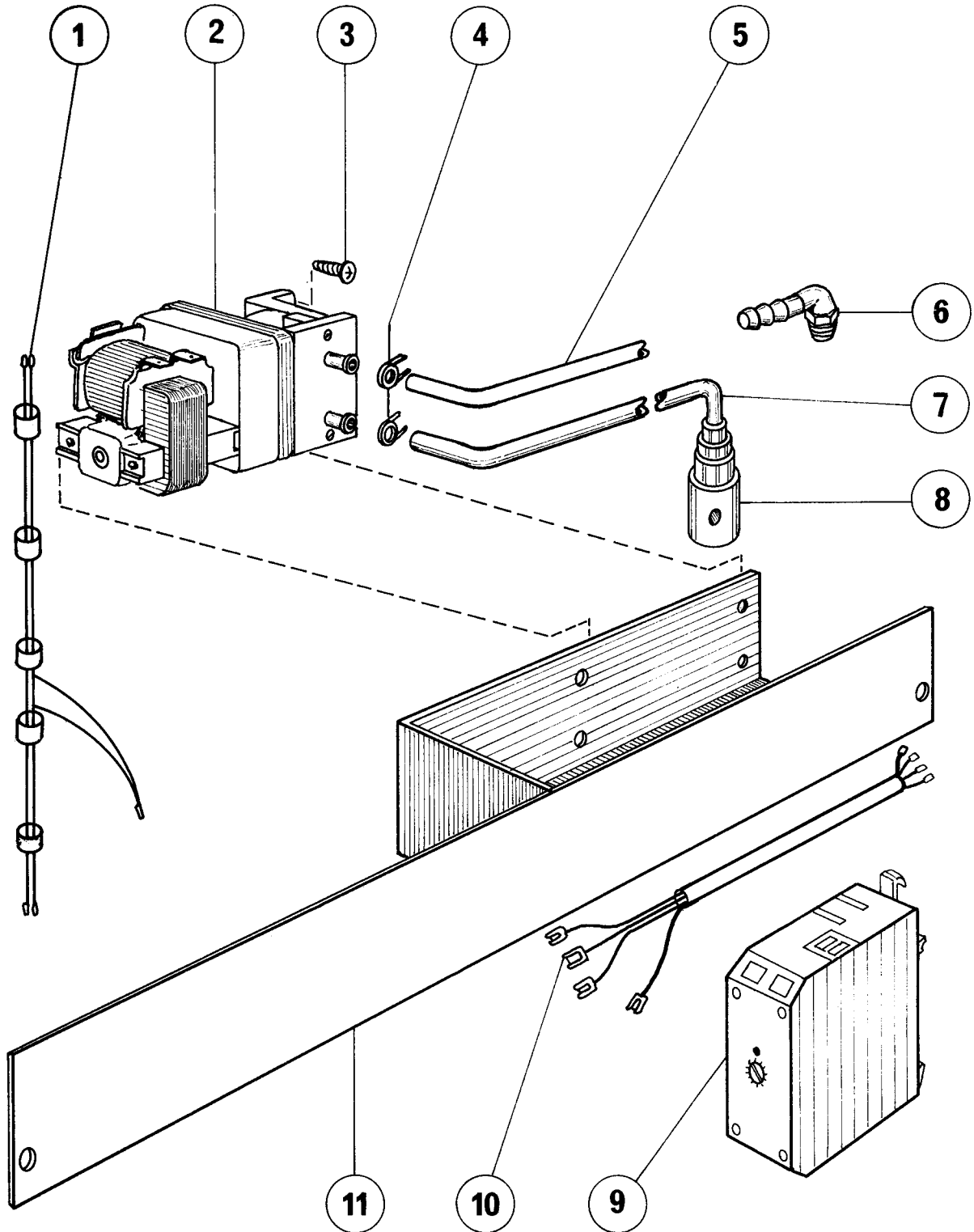

key no. réf. Pos. Nr.	part no. pièces no. Teile-Nr.	part name nom de la pièce Teile-Benennung	qty. qté. Stck.
1	228868	cable assembly faisceau Leitungssortiment	1
2	228022-2	hose-pomp pompe a tuyau Schlauchpumpe	1
3	SD-26-9	self-tapping screw n° 10 x 1/2" truss phil. head vis auto-taraucleuse SP n° 10 x 1/2" Biehschraube 4,8 x 13	2
4	228070-1	hose clip pince Schlauchklemme	2
5	165168-6	hose PVC tuyau PVC PVC-Schlauch	1
6	228755-1	angular screwed socket manchon cornière vissé Winkel-Einschraubstutzen	1
7	165168-1	hose PVC tuyau PVC PVC-Schlauch	1
8	227441	retaining valve clapet de fond Fußventil	1
9	228180-1	time delay relais temporise Zeitrelais	1
10	228723	cable cable Mantelleituna	1
11	228706	base front panel, assembly habillage avant du socle, ensemble Sockelverkleiduna. komolett	1

vsezip.ru

+7(812)987-08-81

+7(812)987-08-81

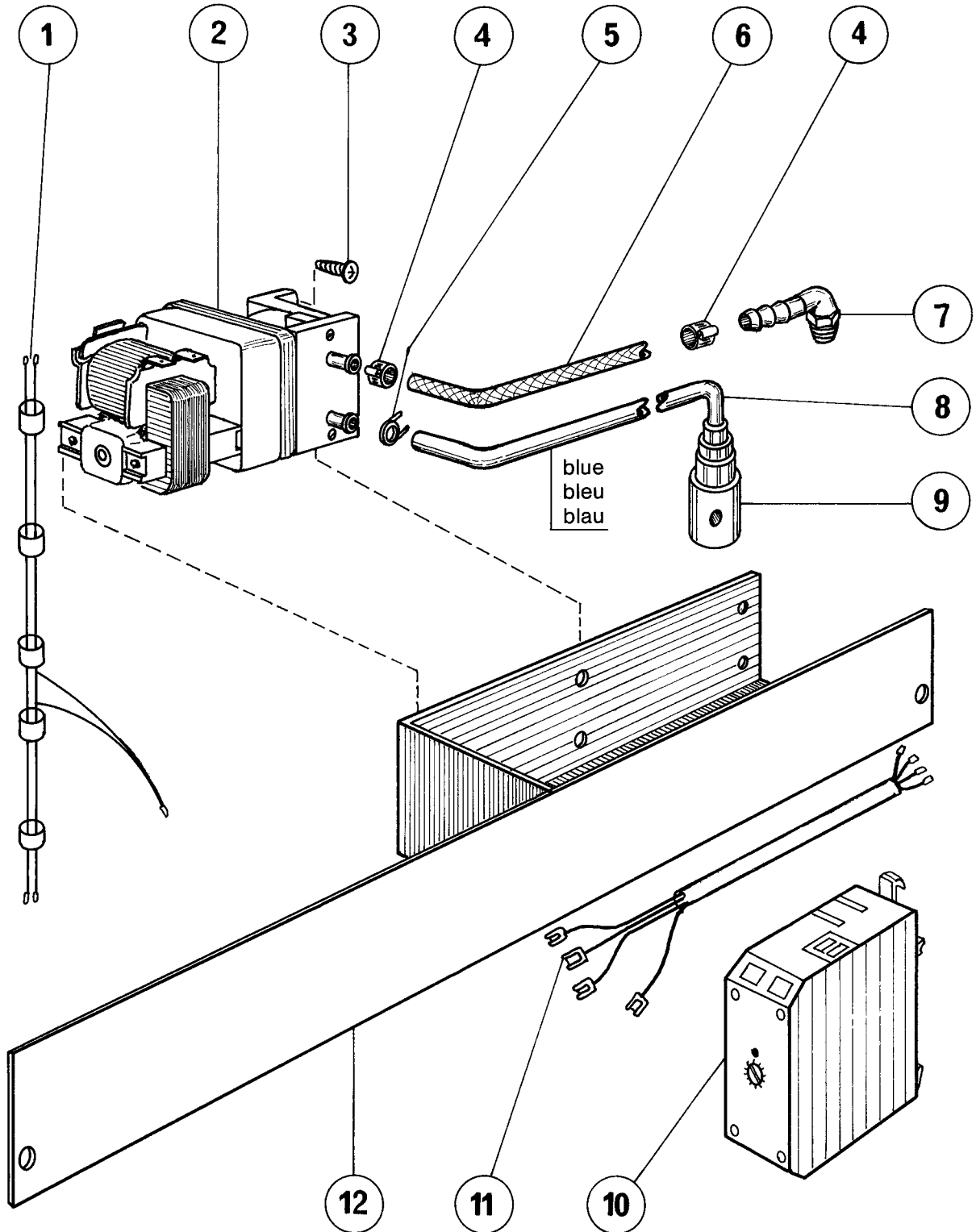

key no. ref. Pos. Nr.	part no. pièces no. Teile-Nr.	part name nom de la pièce Teile-Benennung	qty. qté. Stck.
1	228790	cable assembly faisceau Leitungssortiment	1
2	228022-2	hose pump pompe a tuyau Schlauchpumpe	1
3	SD-26-9	self-tapping screw n° 10 x 1/2" truss phil. head vis auto-taraucleuse SP n° 10 x 1/2" Blechschrabe 4,8 x 13	2
4	116513-2	hose clamp collier Schlauchschelle	2
5	228070-1	hose clip pince Schlauchklemme	1
6	169624-7	hose PVC tuyau PVC PVC-Schlauch	1
7	228755-1	angular screwed socket manchon cornière vissé Winkel-Einschraubstutzen	1
8	228757-1	hose PVC tuyau PVC PVC-Schlauch	1
9	227441	retaining valve clapet de fond Fußventil	1
10	228180-3	time delay relais temporise Zeitrelais	1
11	228723	cable cable Mantelleitung	1
12	228706	base front panel, assembly habillage avant du socle, ensemble Sockelverkleidung, komplett	1

Drain pump
Pompe de vidange
Ablaufpumpe

+7(812)987 08 81

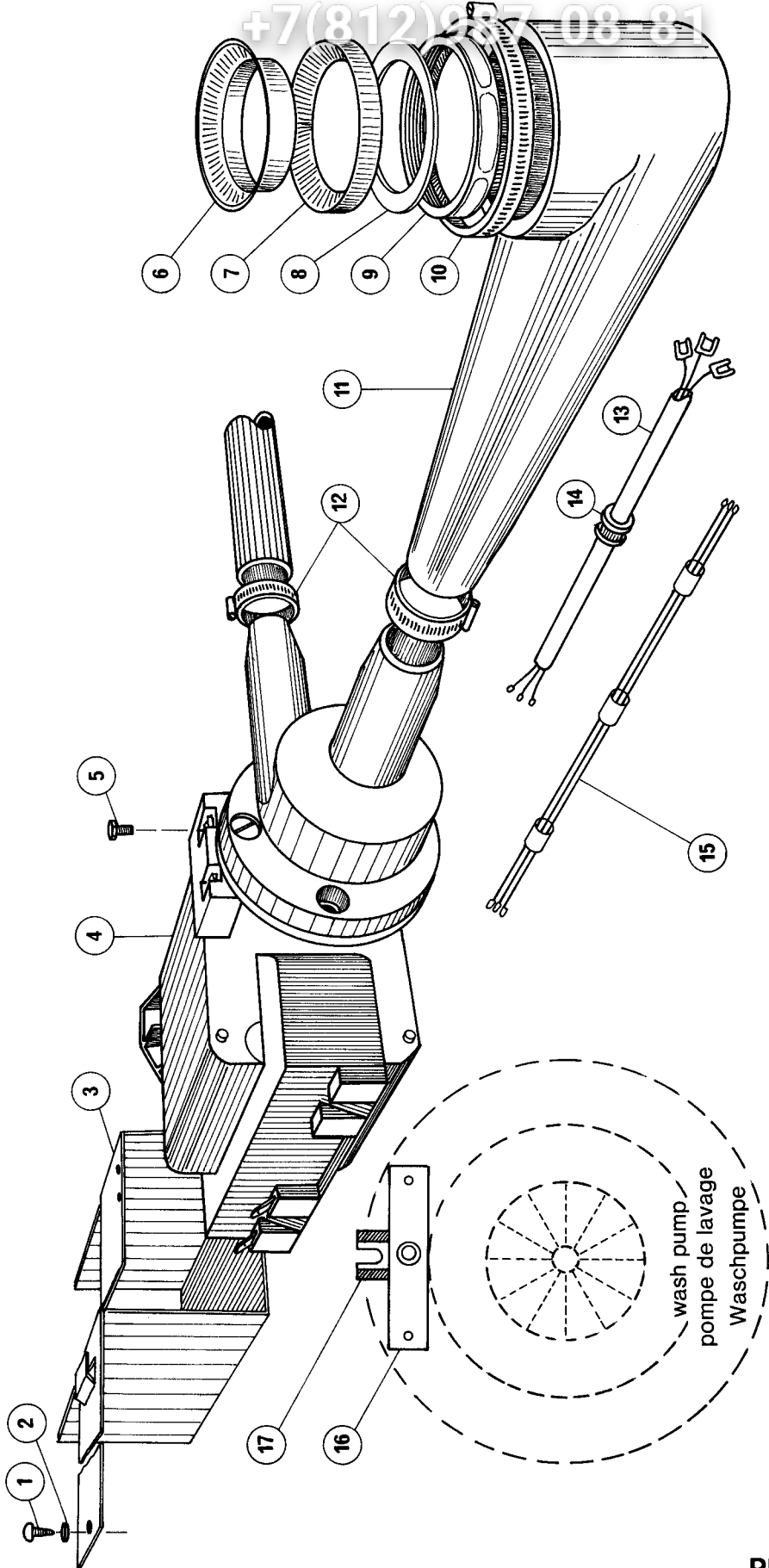

key no. réf. Pos. Nr.	part no. pièces no. Teile-Nr.	part name nom de la pièce Teile-Benennung	qty. qté. Stck.
1		mushroom head screw M 5 x 10 (s.st.) vis RL, M 5 - 10 (inox) Flachrundschraube M 5 x 10 - A2	1
2	168611-4	gasket joint Dichtung	1
3	228923	fixing device, assembly fixation, ensemble Halterung, komplett	1
4	165653-1	drain pump pompe de vidange 220-240/380-415/50-60/1-3/N Ablaufpumpe	1
5	SCM-E-13-6	SCM-E-I 3-6, hexagon head screw M 6 x 10 (s.st.) vis H, M 6 - 10 (inox) Sechskantschraube DIN 933 - M 6 x 10 - A2	2
6	226558-1	drain tunnel entonnoire de vidange Ablaufstutzen	1
7	226556	gasket joint Dichtung	1
8	228694-3	washer rondelle Scheibe	1
9	228924	nut écrou Mutter	1
10	166513-9	hose-clamp collier Schlauchschele	1
11	228919	drain piece piece de vidange Ablaufstück	1
12	166513-1	hose-clamp collier Schlauchschele	2
13	228744	PVC covered cable câble à manteau PVC Mantelleitung	1
14	227748-1	cable-protecting sleeve gaine de cable Kabeldurchführungstülle	1
15	228920	cable assembly faisceau Leitunossortiment	1
16	228917-1	time delay relais temporisé Zeitrelais	1
17	228925	mounting rail rail de montage Traaschiene	1

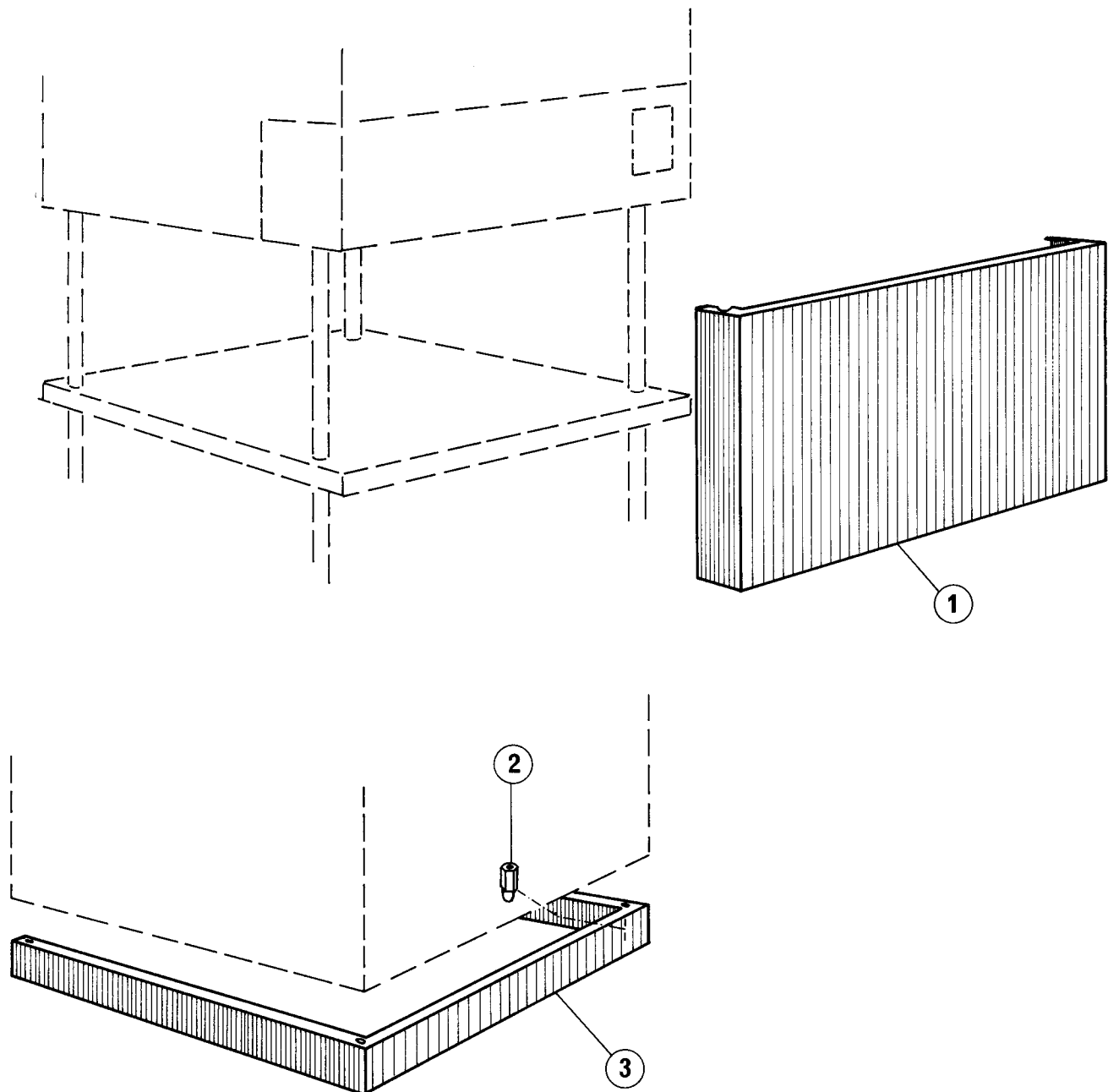

PLE 100 546

key no. réf. Pos. Nr.	part no. pièces no. Teile-Nr.	part name nom de la pièce Teile-Benennung		qty. qté. Stck.
1	228906	panel panneau Verkleidung	FM-30 only slt. FM-30 U nur FM-30 U	1
2	227539	threaded spacer bolt entretoise filetée Zwischenstück mit Gewinde	FM-30 U only slt. FM-30 U nur FM-30 U	4
3	228758	extension piece, 900 mm machine height socle, 900 mm hauteur de machine Sockel 900 mm Maschinenhöhe	FM-30 U only slt. FM-30 U nur FM-30 U	1

vsezip.ru

+7(812)447-08-81

+7(812)987-08-81

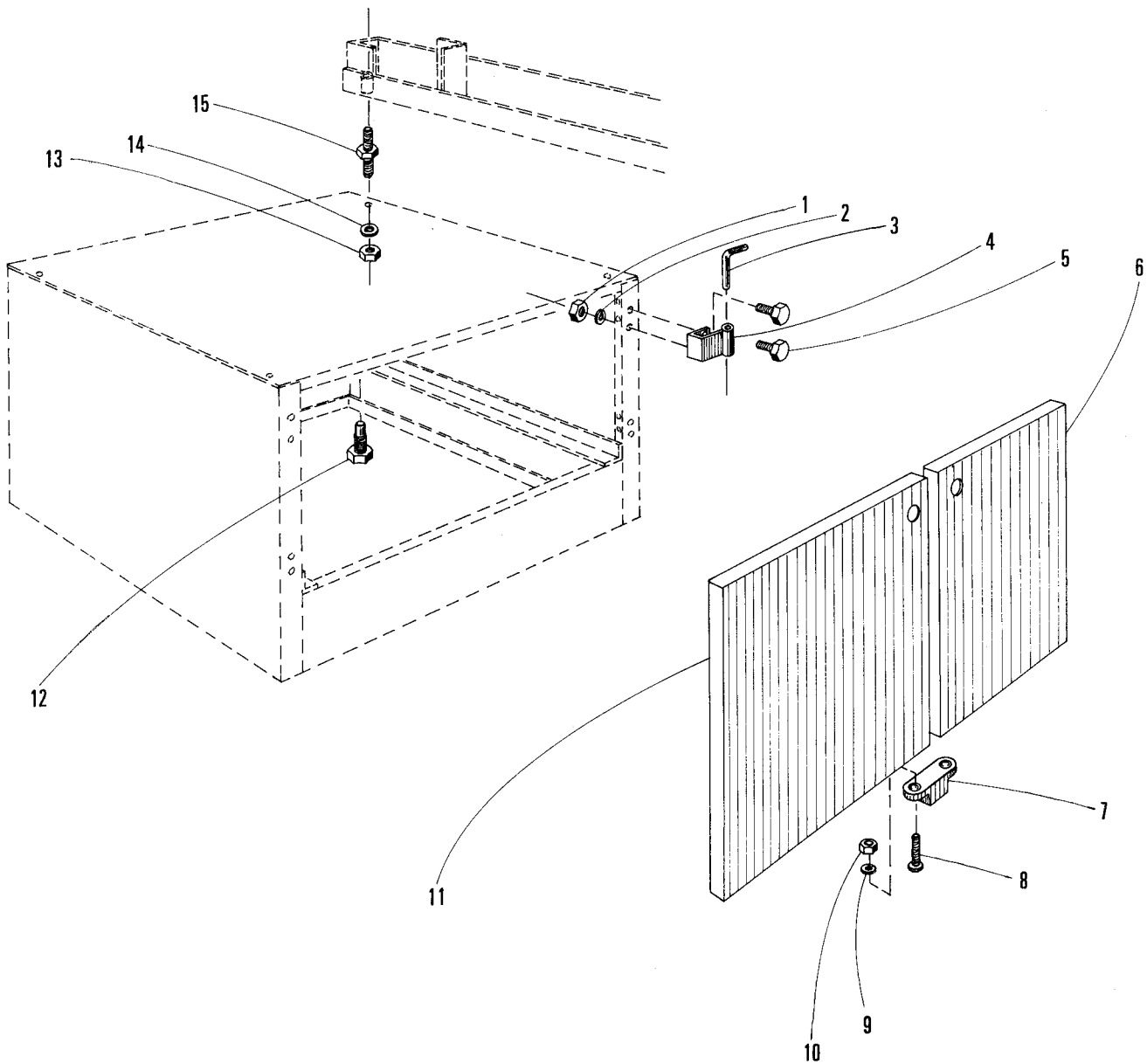

PLE 100 436

key no. réf. Pos. Nr.	part no. pièces no. Teile-Nr.	part name nom de la pièce Teile-Benennung	qty. qté. Stck.
1	NUM-E-2-27	NUM-E-2-27, hexagon nut, M 5 (s.st.) écrou H, M 5 (inox) Sechskantmutter DIN 934 - M 5 - A 2	8
2	LWM-E-2-28	LWM-E-2-28, single coil lockwasher M 5 (s.st.) rondelle WZ 5 (inox) Feclerrina DIN 127 -A 5 - 1.4310	8
3	228129	bolt boulon Bolzen	4
4	228133	hinge charnière Scharnier	4
5		mushroom head screw, M 5 x 15 (s.st.) vis RL M 5 x 15 (inox) Flachrundschrabe M 5 x 15 - A 2	8
6	228101	door, assembly, R.H. porte, ensemble, côté droit Tür, komplett, rechts	1
7	34651-1	magnetic catch aimant Magnet	2
8	SCM-E-1-21	SCM-E-1-21, slotted cheese head screw, M 3 x 10 (s.st.) vis C M 3 - 10 (inox) Zylinderschraube DIN 84 - M 3 x 10 - A 2	4
9	LWM-E-1-1	LWM-E-1-1, single coil lockwasher M 3 (s.st.) rondelle WZ M 3 (inox) Federring DIN 127 -A 3 - 1.4310	4
10	NUM-E-1-3	NUM-E-1-3, hexagon nut, M 3 (s.st.) écrou H, M 3 (inox) Sechskantmutter DIN 934 - M 3 -A 2	4
11	228102	door, assembly, L.H. porte, ensemble, côté gauche Tür, komplett, links	1
12	226945	adjustable foot ped réglable Verstellfuß	4
13	NUM-E-4-27	NUM-E-4-27, hexagon nut, M 12 (s.st.) écrou H, M 12 (inox) Sechskantmutter DIN 934 - M 12 -A 2	4
14	WAM-E-8-44	WAM-E-8-44, plain washer M 12 (s.st.) rondelle M 12 N (inox) Scheibe DIN 125 - B 12 - A 2	4
15	228167	junction bolt boulon de jonction a double filetage Verbindungsteil	4
16	172523	plug bouchon Stopfen	2
	228100	supporting frame, assembly bâti inférieur, ensemble Untergestell, komplett	(not for U.K.) (pas pour l'Angleterre) (nicht für England) 1

Зип Общепит
vsezip.ru
+7(812)987-08-81

As continued product improvement is a policy of HOBART, specifications are subject to change without notice.

Ce catalogue n'est pas contractuel. La Compagnie HOBART se réserve le droit, et sans préavis, d'apporter toutes modifications ou améliorations à ses matériels.

Die Firma HOBART behält sich das Recht vor, an allen ihren Produkten technische Änderungen und Verbesserungen ohne Ankündigung vorzunehmen.