

+7(812)987-08-81

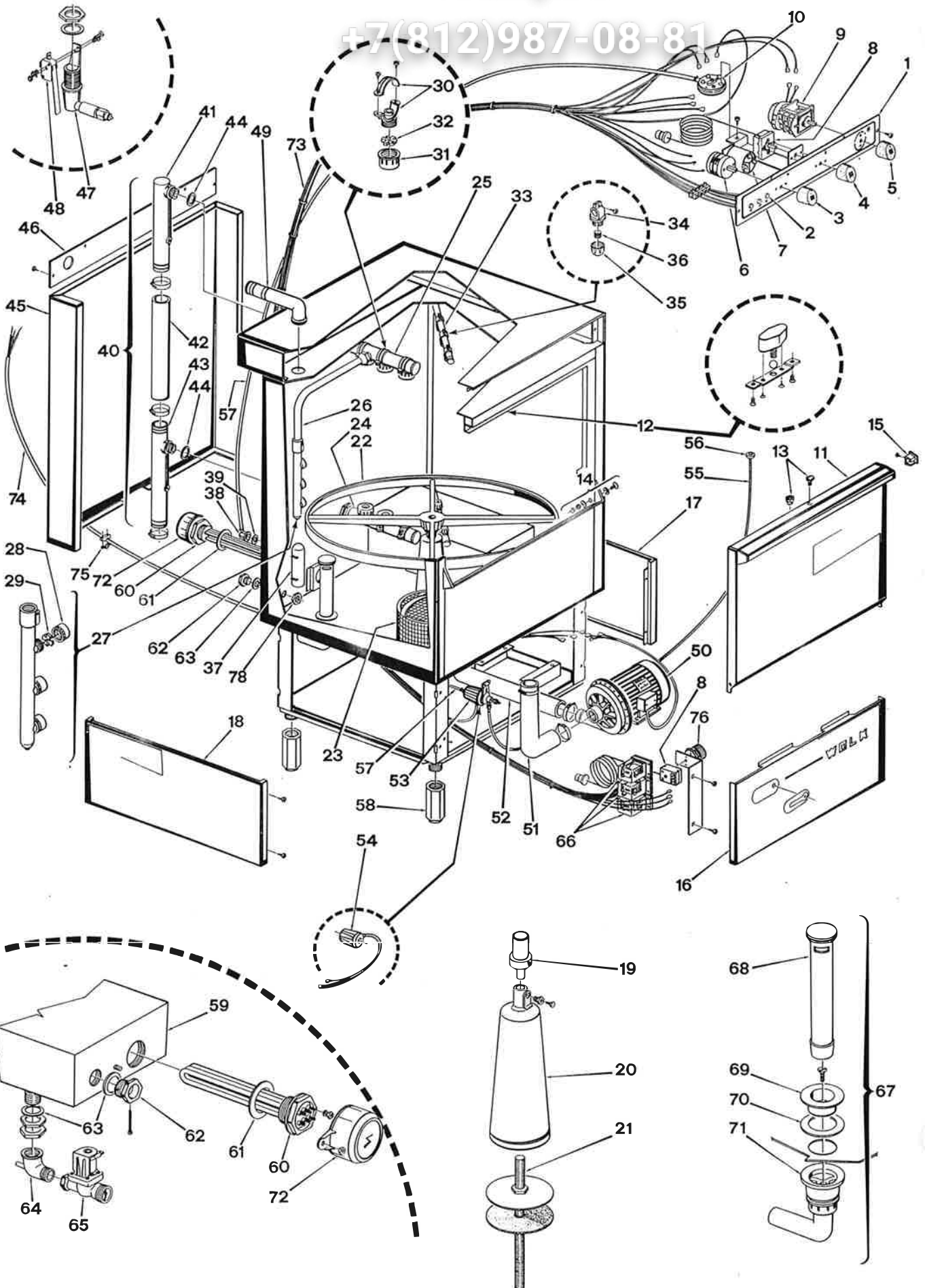

POS.	CODICE CODE KODE	POS.	CODICE CODE KODE	POS.	CODICE CODE KODE	POS.	CODICE CODE KODE
1	02 50 01	32	11 90 02	62	43 50 01		
2	{ 21 60 02	33	99 30 24	63	43 70 31		
	21 60 03	34	11 00 02	64	46 80 21		
	{ 21 60 05	35	14 00 06	65	pag. 93		
3	44 70 07	36	13 80 01	66	22 90 08		
4/5	44 70 08	37	98 40 02	67	99 90 34		
6	21 30 03	38	46 80 29	68	14 20 10		
7	21 20 01	39	{ 45 60 20	69	14 20 01		
8	{ 23 60 07		{ 43 70 19	70	{ 43 70 38		
	23 60 08	41	98 50 02		{ 43 70 33		
9	pag. 90	42	12 70 11	71	99 90 43		
10	22 40 02	43	98 50 01	72	41 50 01		
11	99 90 36	44	43 70 27	73	20 30 27		
12	99 40 06	45	02 20 19	74	20 40 13		
13	99 40 05	46	02 20 18	75	42 50 01		
14	99 90 37	47	99 90 08	76	44 70 04		
15	{ 48 00 15	48	21 80 02	78	41 70 40		
	48 00 16	49	10 80 05				
16	02 00 08	50	pag. 104				
17/18	02 10 06	51	12 70 06				
19	32 20 03	52	12 70 07				
20	99 90 38	53	{ 98 70 01				
21	99 90 39		{ 98 70 05				
22	31 90 02	54	{ 20 10 02				
23	12 10 12		{ 20 10 11				
24	99 00 34	55	14 30 13				
25	99 00 33	56	12 10 17				
26	99 00 35	57	14 30 05				
27	99 90 30	58	46 10 06				
28	14 00 02	59	98 20 04				
29	11 90 01	60	{ 23 00 08				
30	11 00 05		{ 23 00 26				
31	14 00 03	61	43 70 29				

Эл.Общепит

vsezip.ru

+7(812)987-08-81

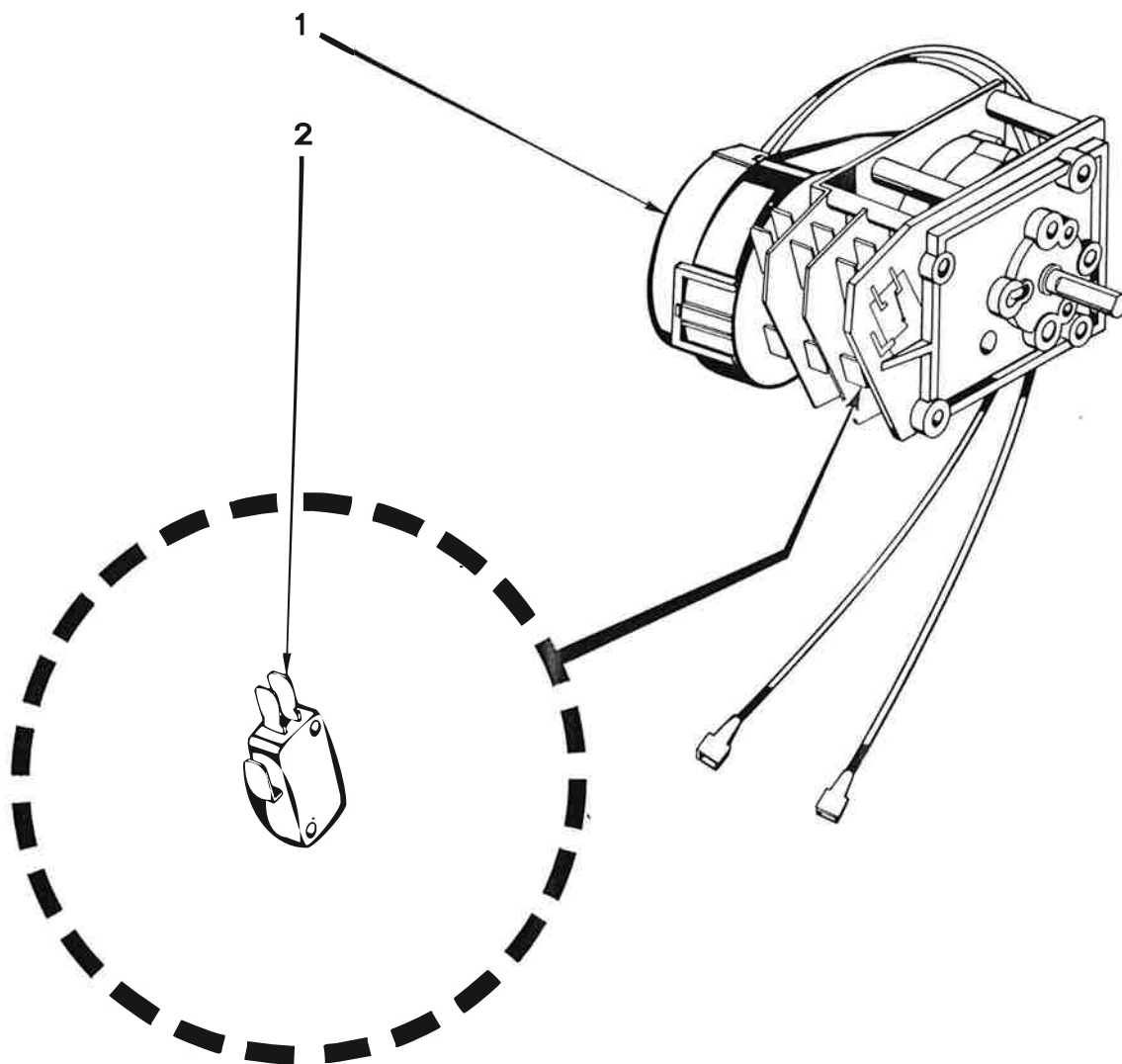

E3 wolk

Timer serie «R» - Timer «R» range

Programmateur serie «R» - Programmschalter Serie «R»

91

10/87

Q.S.	CODICE CODE KODE	DESCRIZIONE - DESCRIPTION - BESCHREIBUNG
1	23 80 25	Timer ciclo 180" - Cronel 2C Cycle timer 180" - Cronel 2C Programmateur cycle 180" - Cronel 2C Programmschalter 180" - Cronel 2C
1	23 80 01	Timer ciclo 180" - Crouzet 3C Cycle timer 180" - Crouzet 3C Programmateur cycle 180" - Crouzet 3C Programmschalter 180" - Crouzet 3C
1	23 80 24	Timer ciclo 180" - Cronel 3C Cycle timer 180" - Cronel 3C Programmateur cycle 180" - Cronel 3C Programmschalter 180" - Cronel 3C
1	23 80 05	Timer ciclo 180" - Cronel 3C Cycle timer 180" - Cronel 3C Programmateur cycle 180" - Cronel 3C Programmschalter 180" - Cronel 3C
1	23 80 16	Timer ciclo 180" - Cronel 3C Cycle timer 180" - Cronel 3C Programmateur cycle 180" - Cronel 3C Programmschalter 180" - Cronel 3C

E3 wolkTimer serie «R»
Programmateur

POS.	CODICE CODE KODE	
1	23 80 09	Timer pompa Drain pump t Programmate Laugenpumpe
2	21 80 09	Micro timer C Microtimer C Minirupteur p Mikroschalter

Этп Общепит

vsezip.ru

+7(812)987-08-81

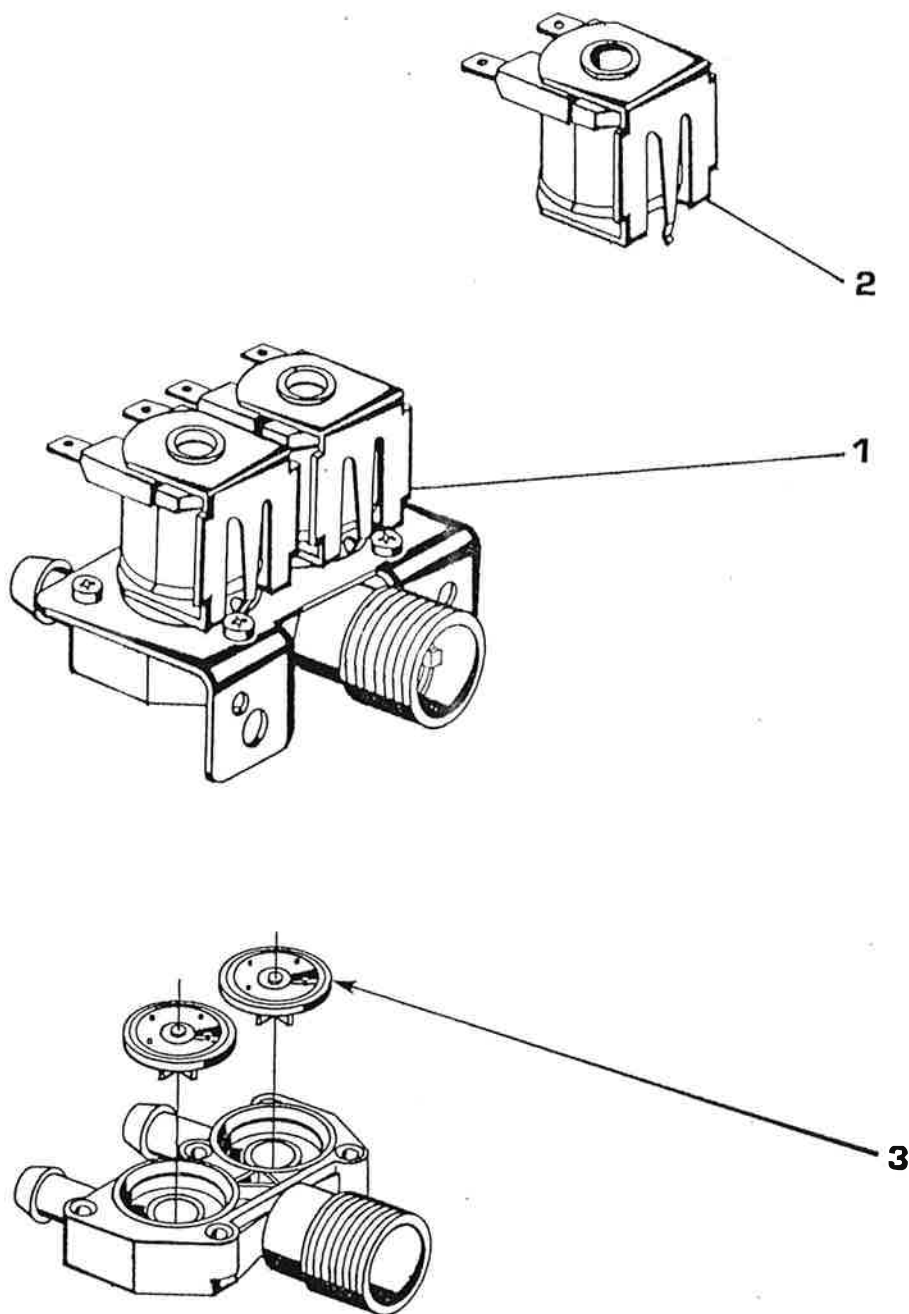
+7(812)987-08-81

POS.	CODICE CODE KODE	DESCRIZIONE - DESCRIPTION - BESCHREIBUNG
1	24 00 06	Valvola - Elbi - 1 via 90° Solenoid valve - Elbi - 1 way 90° Vanne - Elbi - 1 bobine 90° Einweg - Einlassmagnetventil - Elbi - 90° 220-240/50-60/1 Mod. R 495
1	24 00 05	Valvola - Elbi - 1 via 180° Solenoid valve - Elbi - 1 way 180° Vanne - Elbi - 1 bobine 180° Einweg - Einlassmagnetventil - Elbi - 180° 220-240/50-60/1 Mod. R 704 - 706
1	24 00 03	Valvola - 2 vie 180° Solenoid valve - 2 ways 180° Vanne - 2 bobines 180° Zweiweg - Einlassmagnetventil - 180° 220-240/50-60/1 Mod. R 497 - 499 - 501 - 505 - 509 - S 641
1	24 00 02	Valvola - 3 vie 180° Solenoid valve - 3 ways 180° Vanne - 3 bobines 180° Dreiweg - Einlassmagnetventil - 180° 220-240/50-60/1 Mod. R 503 - 507 - 511 - S 643
1	24 00 08	Valvola ottone piccola portata Brass solenoid valve - small capacity Vanne laiton - petite Kleines Einlassmagnetventil aus Messing 220-240/50-60/1 Mod. R 708
1	24 00 07	Valvola ottone grande portata Brass solenoid valve - big capacity Vanne laiton - grande Grosses Einlassmagnetventil aus Messing 220-240/50-60/1 Mod. S 870 fino matricola n° 64902 till serial no. 64902 au matricule n° 64902 bis Maschinen-Nr. 64902

OS.	CODICE CODE KODE	DESCRIZIONE - DESCRIPTION - BESCHREIBUNG
2	20 10 06	Bobina va Coil for so Bobine po Spule für
2	20 10 08	Bobina va Coil for br Bobine va Spule für
2	20 10 07	Bobina va Coil for br Bobine va Spule für
3	29 90 22	Membrana Membrane Membrane Membran

Зин Общепит

vsezip.ru

+7(812)987-08-81

POMPA
WASH PUMP
POMPE
ELEKTROPUMPE

mod. R:
706 - 708

Зип Общепит

104

10/87

vsezip.ru

+7(812)987-08-81

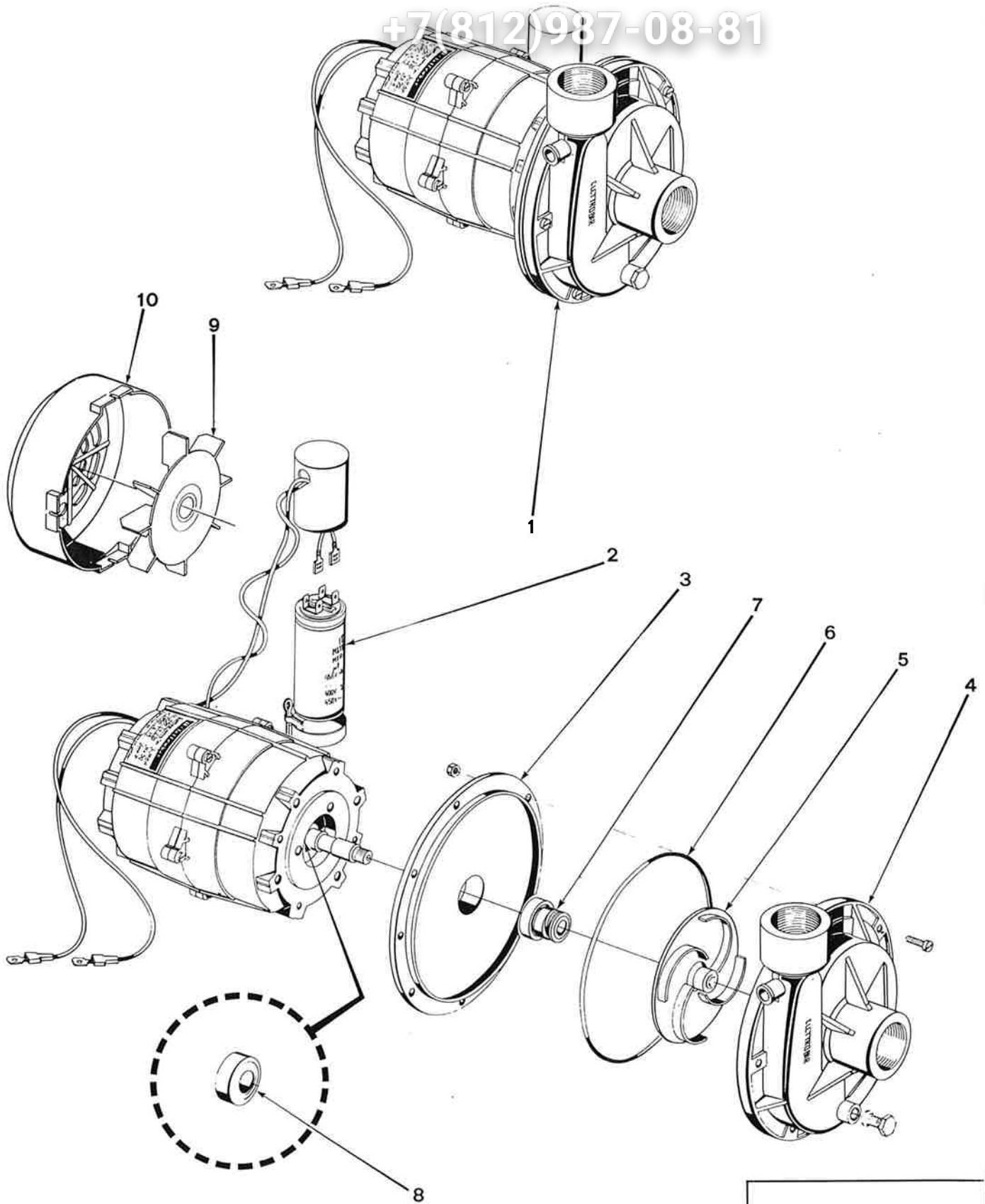

E3 wolk

POMPA
WASH PUMP
POMPE
ELEKTROPUMPE

mod. R:
706 - 708

105

POMPA
WASH PUMP
POMPE
ELEKTROPUMPE

mod. R:
706 - 708

Зип Общедит

POS.	CODICE CODE KODE	DESCRIZIONE - DESCRIPTION - BESCHREIBUNG	POS.	CODICE CODE KODE	
1	13 00 24	Pompa 1295 FIR HP 1,2 Wash pump 1295 FIR HP 1,2 Pompe 1295 FIR HP 1,2 Elektropumpe 1295 FIR HP 1,2	5	12 40 22	Girante 1295 FIR Impellor 1295 FIR Turbine 1295 FIR Pumpenflügel 129
1	13 00 29	Pompa 1295 FIR HP 1,2 Wash pump 1295 FIR HP 1,2 Pompe 1295 FIR HP 1,2 Elektropumpe 1295 FIR HP 1,2	5	12 40 09	Girante T 140 50 Impellor T 140 50 Turbine T 140 50 Pumpenflügel T 14
1	13 00 30	Pompa 1295 FIR HP 1,2 Wash pump 1295 FIR HP 1,2 Pompe 1295 FIR HP 1,2 Elektropumpe 1295 FIR HP 1,2	6	45 60 23	OR 1295 FIR O-ring 1295 FIR Joint thorique 129 O-Ring Dichtung 1
1	13 00 09	Pompa LC T 140 HP 1 Wash pump LC T 140 HP 1 Pompe LC T 140 HP 1 Elektropumpe LC T 140 HP 1	6	45 60 24	OR T 140 O-ring T 140 Joint thorique T 14 O-Ring Dichtung T
2	20 60 05	Condensatore T 140, 1295 FIR Condenser T 140, 1295 FIR Condensateur T 140, 1295 FIR Kondensator T 140, 1295 FIR	7	14 10 02	Tenuta meccanica Seal 1295 FIR, T 1 Presse etoupe 129 Gleitringdichtung 1
3	31 50 04	Flangia + cappello 1295 FIR Flange int. 1295 FIR Flansque int. 1295 FIR Flansch 1295 FIR	8	31 40 02	Cuscinetto T 140 Bearing T 140 Roulement T 140 Kugellager T 140
3	31 50 09	Flangia + cappello T 140 Flange T.140 Flansque T 140 Flansch T 140	9	33 50 03	Ventola 1295 FIR Fan 1295 FIR Turbine de refroidis Flügel 1295 FIR
4	11 60 04	Corpo pompa 1295 FIR Flange ext. 1295 FIR Flansque ext. 1295 FIR Pumpengehäuse 1295 FIR	9	33 50 05	Ventola T 140 Fan T 140 Turbine de refroidis Flügel T 140
4	11 60 11	Corpo pompa T 140 Flange ext. T 140 Flansque ext. T 140 Pumpengehäuse T 140	10	31 30 03	Copriventola 1295 F Fan protection 1295 Protection turbine 1 Flügelschutz 1295 F
5	12 40 04	Girante 1295 FIR 50 Hz. Impellor 1295 FIR 50 Hz. Turbine 1295 FIR 50 Hz. Pumpenflügel 1295 FIR 50 Hz.	10	31 30 06	Copriventola T 140 Fan protection T 14 Protection turbine T Flügelschutz T 140

E3 wolk

+7(812)987-08-81

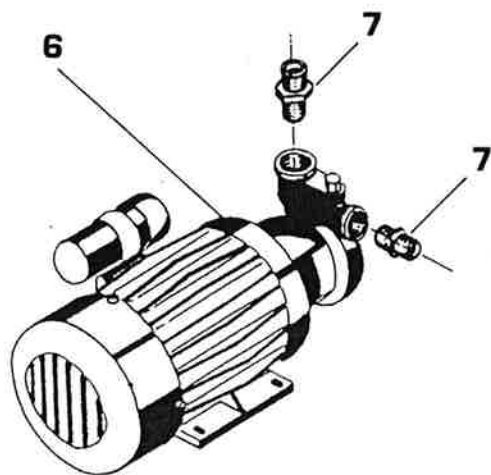
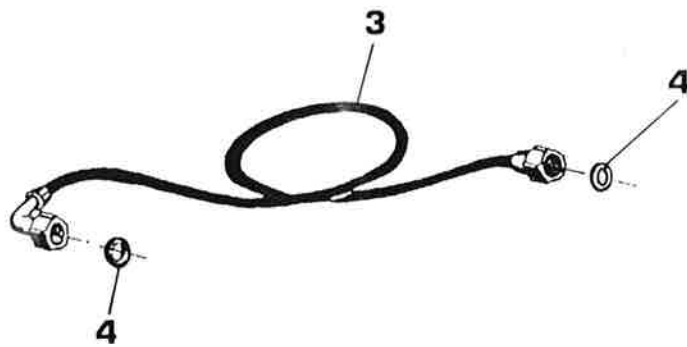
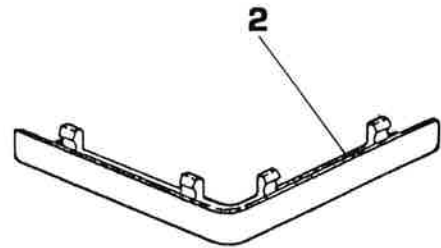
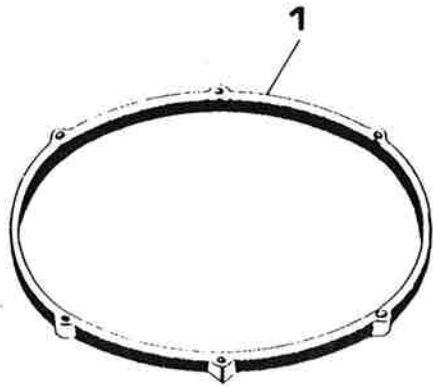

+7(812)987-08-81

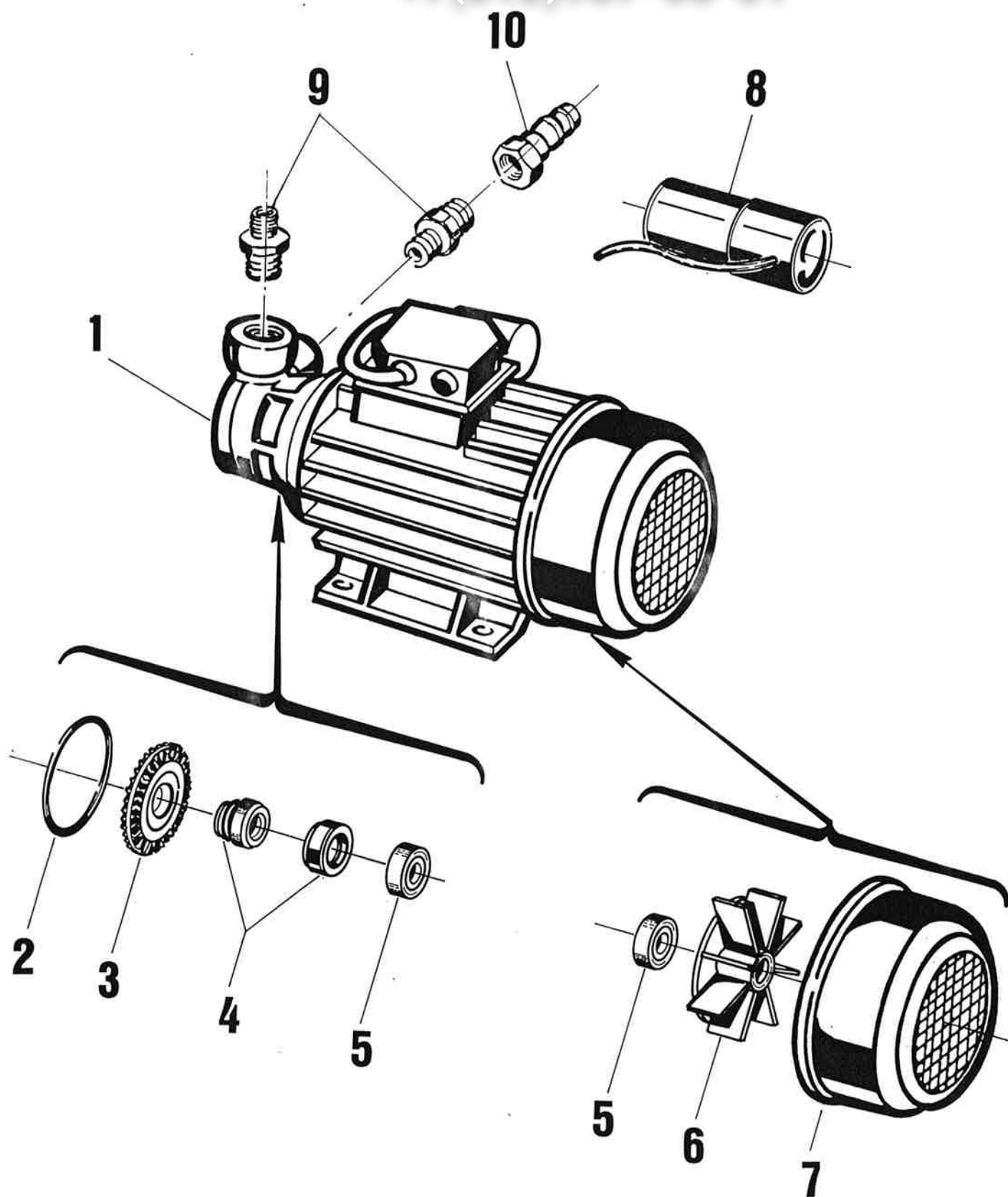

DESCRIZIONE - DESCRIPTION - BESCHREIBUNG

+7(812)987-08-81

POS.	CODICE CODE KODE	DESCRIZIONE - DESCRIPTION - BESCHREIBUNG
1	13 00 13	<p>Pompa ausiliaria Dab K 30 HP 0,4 Rinse booster pump Dab K 30 HP 0,4 Pompe rincage Dab K 30 HP 0,4 Nachspülpumpe Dab K 30 HP 0,4</p> <p>220/50/1</p> <p>Per tutti i modelli For all the models Tous modeles Für alle Modelle</p>
1	13 00 52	<p>Pompa ausiliaria Dab K 30 HP 0,4 Rinse booster pump Dab K 30 HP 0,4 Pompe rincage Dab K 30 HP 0,4 Nachspülpumpe Dab K 30 HP 0,4</p> <p>240/50/1</p> <p>Per tutti i modelli For all the models Tous modeles Für alle Modelle</p>
2	45 60 37	<p>OR K 30 O-ring K 30 Joint thorique K 30 O-Ring Dichtung K 30</p>
3	12 40 15	<p>Girante K 30 Impellor K 30 Turbine K 30 Pumpenflügel K 30</p>
4	14 10 02	<p>Tenuta meccanica K 30 Seal K 30 Presse etoupe K 30 Gleitringdichtung K 30</p>
5	31 40 01	<p>Cuscinetto K 30 Bearing K 30 Roulement K 30 Kugellager K 30</p>
6	33 50 07	<p>Ventola K 30 Fan K 30 Turbine de refroidissement K 30 Flügel K 30</p>
7	31 30 08	<p>Copriventola K 30 Fan protection K 30 Protection turbine K 30 Flügelschutz K 30</p>
8	20 60 01	<p>Condensatore K 30 Condenser K 30 Condensateur K 30 Kondensator K 30</p>
9	46 80 26	<p>Raccordo K 30 Connection K 30 Raccord K 30 Anschluss K 30</p>
10	45 30 02	<p>Raccordo pompa ausiliaria Dab K 30 Rinse booster pump connection Dab K 30 Raccord pompe rincage Dab K 30 Nachspülpumpeanschluss Dab K 30</p> <p>Mod. S 850 - 870 - 950</p>

+7(812)987-08-81

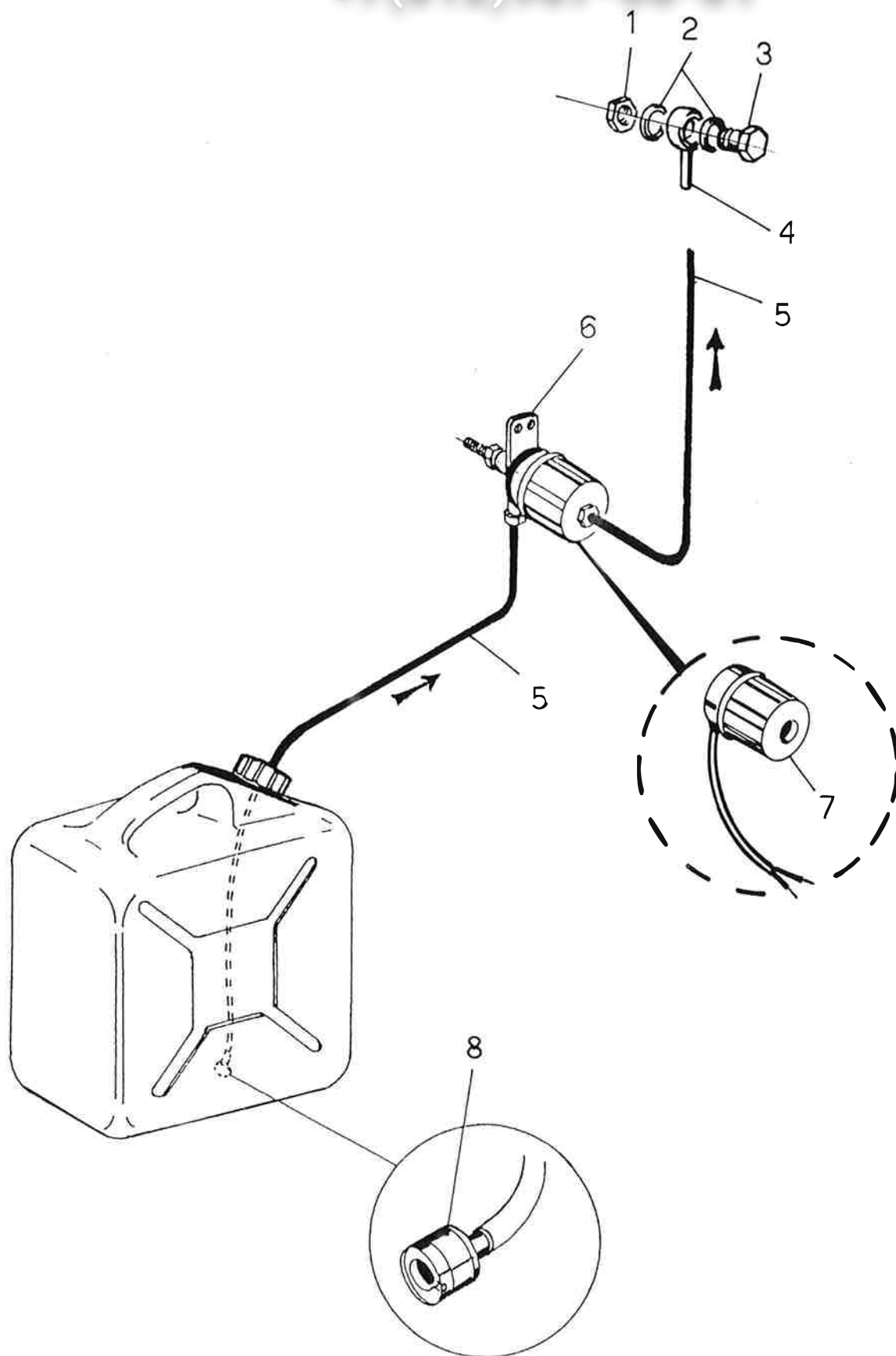



DOSATORE SAPONE
LIQUID DETERGENT DISPENSER
DOSEUR DU PRODUIT DE LAVAGE
SPUELMITTEL-DOSIERGERAET

121

10/87

POS.	CODICE CODE KODE	POS.	CODICE CODE KODE	POS.	CODICE CODE KODE	POS.	CODICE CODE KODE
1	41 70 16						
2	43 70 07						
3	46 80 24						
4	46 80 23						
5	14 30 14						
6	98 70 12						
7	20 10 18						
8	98 60 02						

+7(812)987-08-81

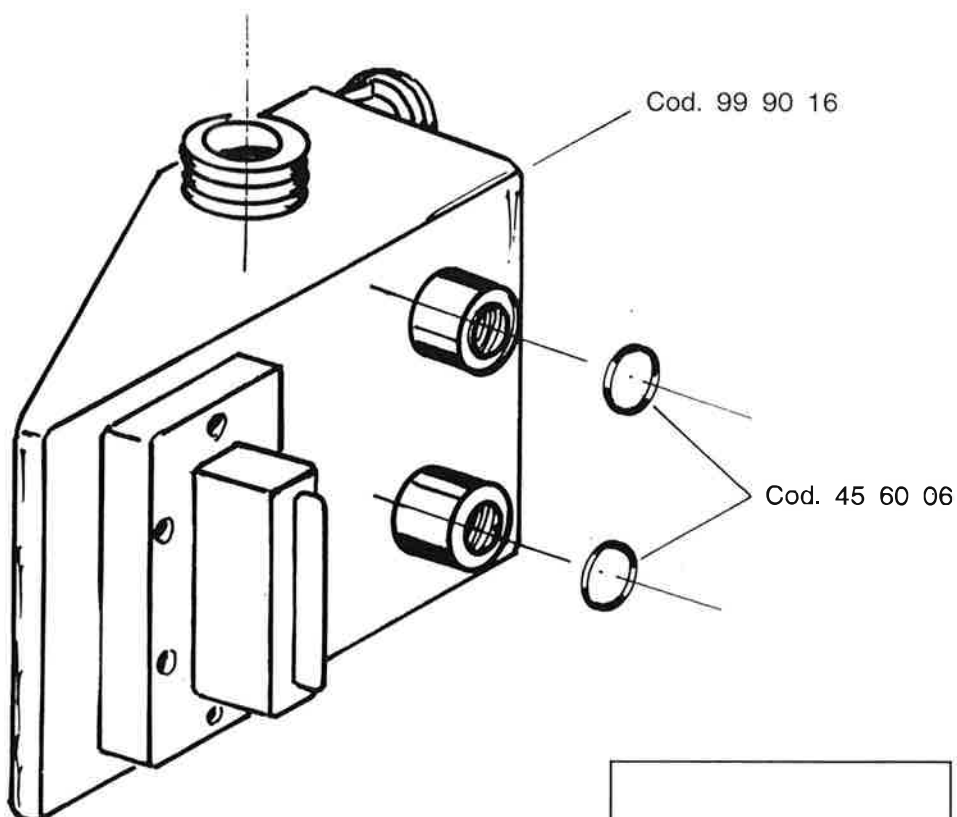
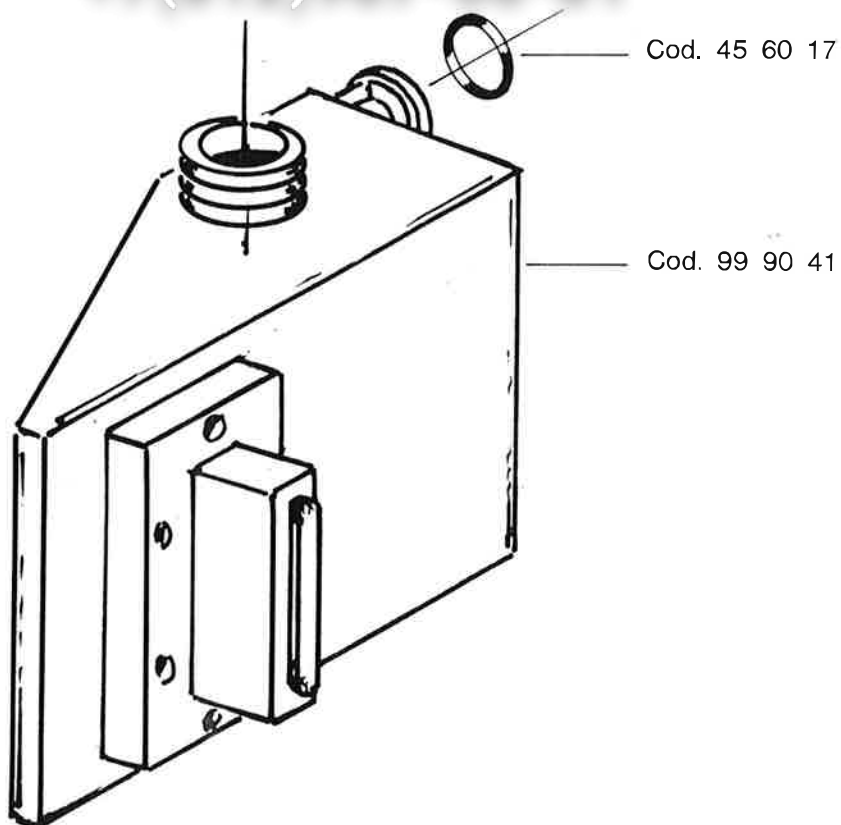

NUOVO
NEW
NOUVEAU
NEU

DA MATRICOLA N° 68473
DE MATRICULE NR. 68473
FROM SERIAL NO. 68473
AB MASCHINEN NR. 68473

E3 wolk

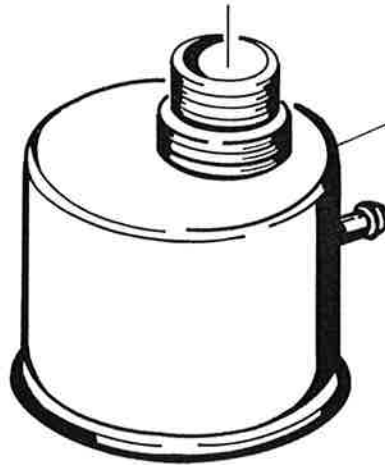
+7(812)987-08-81

Cod. 40 69 99

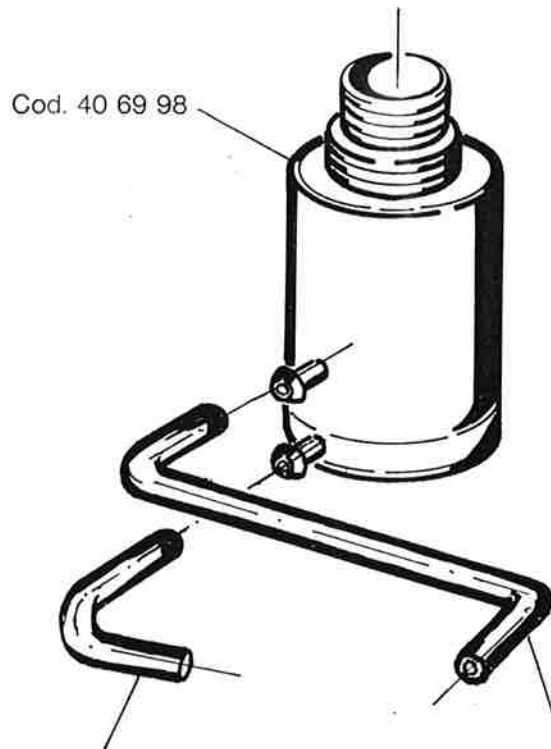

Cod. 40 69 98

Cod. 14 31 05

Cod. 14 31 06

**NUOVO
NEW
NEU
NOUVEAU**DA MATRICOLA N° 92582
FROM SERIAL NO. 92582
AB MASCHINEN NR. 92582
DU MATRICULE NO. 92582