

Ersatzteilliste

Spare parts list

Liste de pièces détachées

Зип Общепит

vsezip.ru

+7(812)987-08-81



Geschirrspülautomat

Dishwashing machines

Machine à laver la vaisselle

DV 40 N

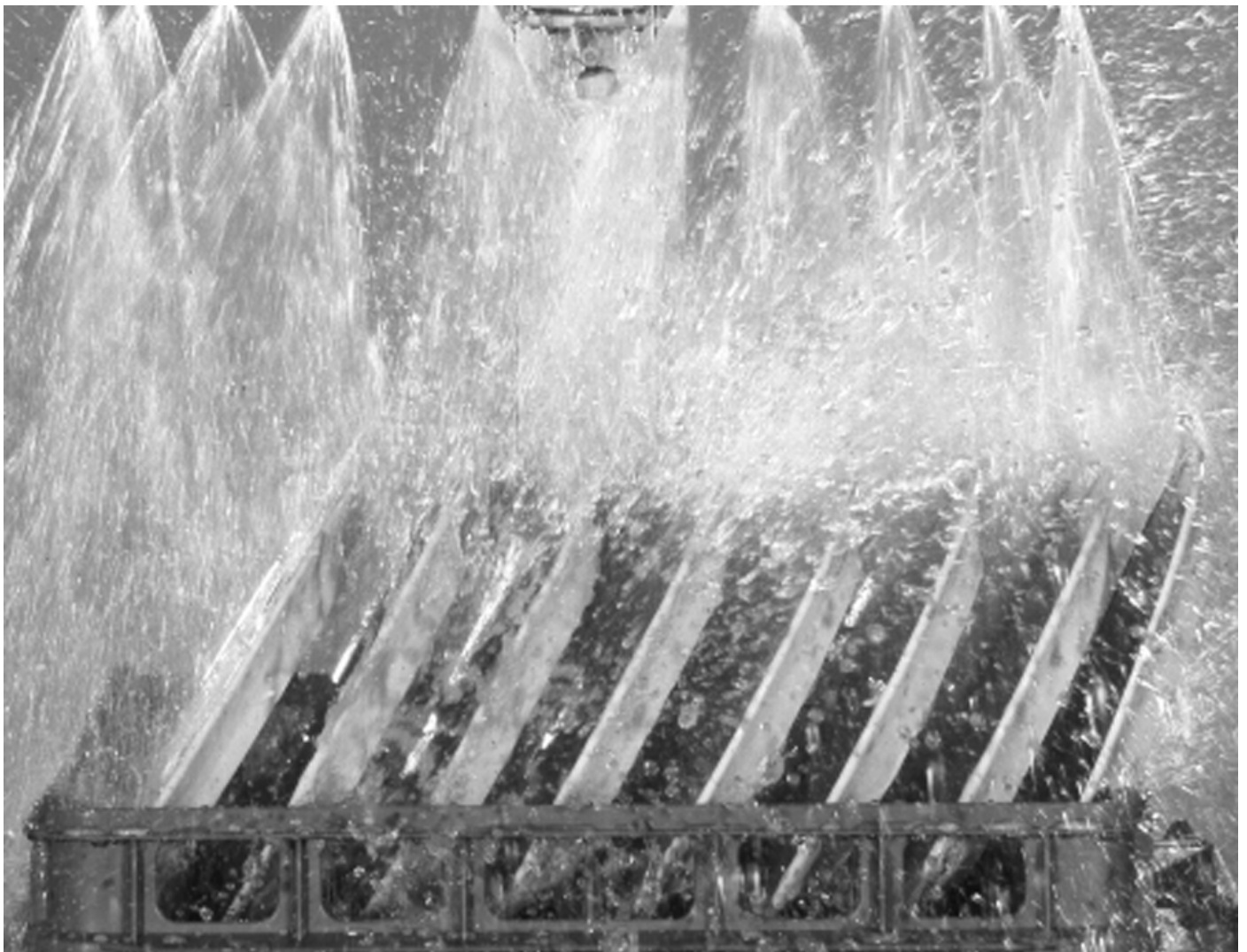

Зип Общепит

DV 40 N

+7(812)987-08-81

INHALTSVERZEICHNIS:	CONTENTS:	CONTENU:
1.1 WASCHPUMPE	WASH PUMP	POMPE DE LAVAGE
2.5 PUMPENANSAUGUNG	PUMP SUCTIONING	ASPIRATION DE POMPE
3.11 WASCH- UND NACHSPÜLSYSTEM	WASHING AND RINSING SYSTEM	SYSTEME DE LAVAGE ET RINÇAGE
4.8 MAGNETVENTIL	SOLENOID VALVE	ELECTROVANNE
5.1 RÜCKSAUGEVERHINDERER	REFLUX PREVENTOR	DISPOSITIF ANTI-RETOUR
6.4 NIVEAUREGELUNG	LEVEL CONTROL	REGULATION DE NIVEAU
8.9 EINBAUBOILER	INCORPORATED BOILER	SURCHAUFFEUR INCORPORE
9.1 TANKHEIZUNG	TANK HEATING	CHAUFFAGE DE BAC
10.5 KLARSPÜLERDOSIERUNG	RINSE AID DOSING UNIT	DOSEUR DE PRODUIT TENSIO-ACTIF
11.21 ELEKTRONIKSTEUERUNG	ELECTRONIC CONTROL	COMMANDE ELECTRONIQUE
12.7 ELEKTROTEILE	ELECTRICAL PARTS	PIECES ELECTRIQUES
13.13 BAUGRUPPEN/EINZELTEILE	COMPONENT BLOCKS/PARTS	BLOCS/PIECES DETACHEES
14.3 HAUBENGESTÄNGE	HOOD ROD	BARRE DE CAPOT

	KENNZEICHNUNG DER ERSATZTEILE	SPECIAL MARKS OF SPARES	MARQUAGE SPECIALES DES PIECES
* / V	DIESE TEILE EMPFEHLEN WIR AUF LAGER ZU LEGEN!	WE RECOMMEND TO STORE THESE PARTS!	NOUS RECOMMANDONS DE PRENDRE CES PIECES EN STOCK!
V	VERSCHLEISSTEIL!	WEAR AND TARE PART!	PIÈCE D'USURE!
	ÄNDERUNGEN IN AUSFÜHRUNG UND KONSTRUKTION VORBEHALTEN.	WE RESERVE THE RIGHT TO CHANGE EXECUTION AND CONSTRUCTION.	NOUS NOUS RESERVONS LE DROIT DE CHANGER L'EXECUTION ET LA CONSTRUCTION.

MEIKO Maschinenbau GmbH & Co. KG
Englerstraße 3
D-77652 Offenburg
Telefon: 0781 / 203 - 0
Telefax: 0781 / 203 - 1179
www.meiko.de
e-mail: info@meiko.de

01.01 WASCHPUMPE (0,55 KW)

01.01 WASH PUMP (0,55 KW)

01.01 POMPE DE LAVAGE (0,55 KW)

Зип Общепит

vsezip.ru

+7(812)987-08-81



DV40N
01.12.2000/FH

POS	IDENT. NR. IDENT. NO.	BEZEICHNUNG	DESIGNATION	DESIGNATION
1	* 0501085	PUMPE PU 0,5/3911, 0,55 KW 230 V 50 HZ, 2800 U/MIN	PUMP PU 0,5/3911, 0,55 KW 230 V 50 HZ, 2800 RPM	POMPE PU 0,5/3911, 0,55 KW 230 V 50 HZ, 2800 TR/MIN
2	0335005	SECHSKANTMUTTER DIN 934 - M 4	HEXAGON NUT DIN 934 - M 4	ECROU A SIX PANS DIN 934 - M 4
3	0501105	LAGERSCHILD MIT PUMPEN- DECKEL	END SHIELD WITH PUMP LIDO	FLASQUE AVEC COUVERCLE DE POMPE
4	* 9500310	PUMPENGEHÄUSEDICHTUNG	PACKING FOR PUMP HOUSING	JOINT POUR CORPS DE POMPE
5	V 0501095	GLEITRINGDICHTUNG KPL.	SLIDING SEAL COMPL.	JOINT AXIAL CPL.
6	* 0501092	PUMPENLAUFRAD	PUMP WHEEL	ROUE DE POMPE
7	0501091	PUMPENGEHÄUSE	PUMP HOUSING	CORPS DE POMPE
8	0303015	SECHSKANTSCHRAUBE DIN 933 M 4 X 25	HEXAGON SCREW DIN 933 M 4 X 25	VIS A SIX PANS DIN 933 M 4 X 25
9	* 0501090	KONDENSATOR 12 µF	CONDENSER 12 µF	CONDENSEUR 12 µF
10	0640007	SCHLAUCH SCHWARZ DIN 904 - Ø38 X 4	HOSE BLACK DIN 904 - Ø38 X 4	TUYAU FLEXIBLE NOIR DIN 904 - Ø38 X 4
10	8002454	SCHLAUCH GLASKLAR Ø35 X 5 X 70	HOSE TRANSPARENT Ø35 X 5 X 70	TUYAU FLEXIBLE TRANSPARENT Ø35 X 5 X 70
11	0233046	SCHLAUCHKLEMME 32 - 50	HOSE CLAMP 32 - 50	PINCE/TUYAU SOUPLE 32 - 50
	0467010	TYPENSCHILD (NICHT GEZEICHNET)	LABEL (NOT DESIGNED)	PLAQUE AUTOCOLLANTE (NON DESIGNEE)

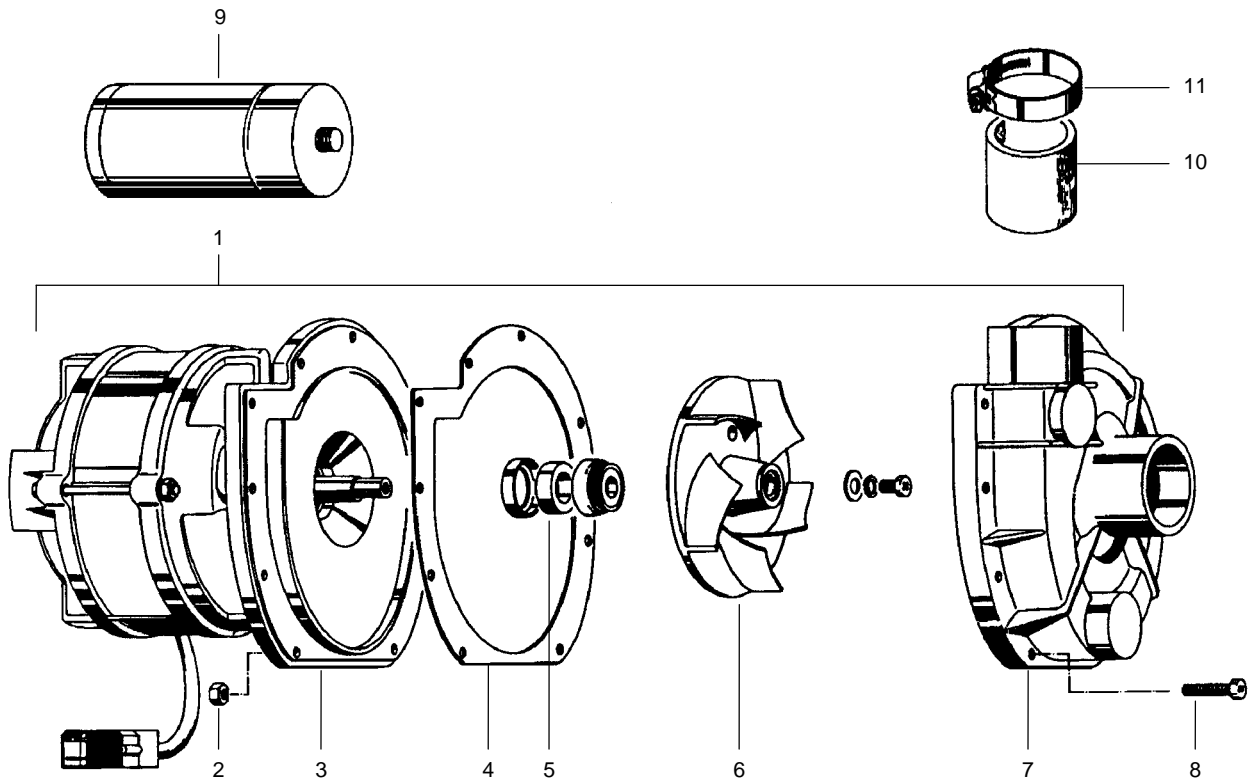

02.05 PUMPENANSAUGUNG

02.05 PUMP SUCTIONING

02.05 ASPIRATION DE POMPE

Зип Общепит

vsezip.ru

+7(812)987-08-81



DV40N
01.12.2000/FH

POS	IDENT. NR. IDENT. NO.	BEZEICHNUNG	DESIGNATION	DESIGNATION
1	8004455	PUMPENSUMPF MIT STANDROHR DV 40/80 T(FA)	PUMP SUMP WITH STAND PIPE DV 40/80 T(FA)	CUVETTE DE POMPE AVEC BONDE DE TROP PLEIN DV 40/80 T(FA)
2	* 0401061	O-RING 206,5 X 3,53	O-RING 206,5 X 3,53	BAGUE O 206,5 X 3,53
3	0620457	STANDROHR 255 LANG, K 413	STAND PIPE 255 LONG, K 413	BONDE DE TROP-PLEIN 255 LONG, K 413
4	0620346	SIEB MIT SCHMUTZRINNE K 337	FILTER WITH DIRT TRAP K 337	TAMIS AVEC PROFILE A DECHETS K 337
5	0233041	SCHLAUCHKLEMME 40 - 60	HOSE CLAMP 40 - 60	PINCE/TUYAU SOUPLE 40 - 60
6	8002454	SCHLAUCH GLASKLAR Ø35 X 5 X 70	HOSE TRANSPARENT Ø35 X 5 X 70	TUYAU FLEXIBLE TRANSPARENT Ø35 X 5 X 70
7	0233046	SCHLAUCHKLEMME 32 - 50	HOSE CLAMP 32 - 50	PINCE/TUYAU SOUPLE 32 - 50

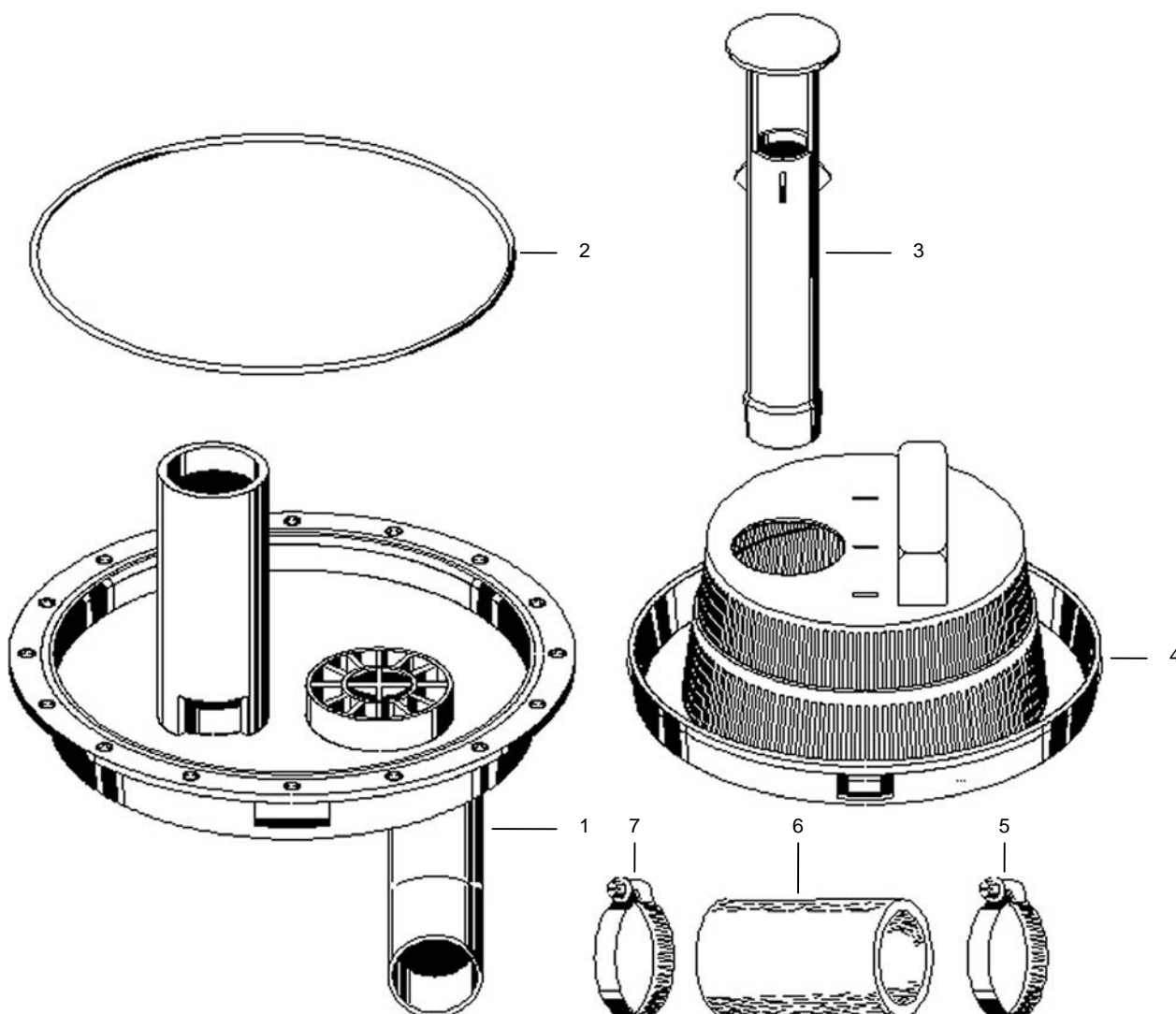

3.11 WASCH- UND NACHSPÜLSYSTEM

3.11 WASHING AND RINSING SYSTEM

3.11 SYSTEME DE LAVAGE ET RINÇAGE

POS	IDENT. NR. IDENT. NO.	BEZEICHNUNG	DESIGNATION	DESIGNATION
1	8660464	SECHSKANTMUTTER R 1/2" X 5	HEXAGON NUT R 1/2" X 5	ECROU A SIX PANS R 1/2" X 5
2	8004468	DISTANZSCHEIBE	SPACER	PLAQUE D'ECARTEMENT
3	* 0401016	O-RING 21 X 2	O-RING 21 X 2	BAGUE O 21 X 2
4	8004454	STEIGROHR KPL.	ASCENDING PIPE COMPL.	TUYAU ASCENDANT COMPL.
5	V 8004475	BEFESTIGUNGSROHR OBEN KPL.	UPPER FIXING TUBE COMPL.	TUYAU DE FIXATION SUPERIEUR COMPL.
6	0330019	BLECHSCHRAUBE DIN 7981 4,2 X 9,5	SHEET METAL SCREW DIN 7981 4,2 X 9,5	VIS A TOLE DIN 7981 4,2 X 9,5
7	0620385	WASCHARM 1, LANG, K 303 SCHLITZ INNEN SCHRÄG	WASH ARM 1, LONG, K 303 SLIT INTERIOR OBLIQUE	BRAS DE LAVAGE 1, LONG, K 303 FENTE INTERIEURE OBLIQUE
	0620386	WASCHARM 2, LANG, K 304 SCHLITZ INNEN GERADE	WASH ARM 2, LONG, K 304 SLIT INTERIOR STRAIGHT	BRAS DE LAVAGE 2, LONG K 304 FENTE INTERIEURE DROITE
8	0233046	SCHLAUCHKLEMME 32 - 50	HOSE CLAMP 32 - 50	PINCE/TUYAU SOUPLE 32 - 50
9	8002454	SCHLAUCH KLARSICHT Ø35 X 5 X 70	TRANSPARENT HOSE Ø35 X 5 X 70	TUYAU TRANSPARENT Ø35 X 5 X 70
10	0409000	DICHTUNG 4 X 8 X 1	PACKING 4 X 8 X 1	JOINT 4 X 8 X 1
11	0308030	ZYLINDERSCHRAUBE DIN 84 M4 X 40	PAN HEAD SCREW DIN 84 M4 X 40	VIS A TETE CYLINDRIQUE DIN 84 M4 X 40
12	* 0621036	Y-STÜCK YS 13	Y-PIECE YS 13	PIECE DE Y YS 13
13	0640012	SCHLAUCH GRAU 1/2"	HOSE GREY 1/2"	TUYAU FLEXIBLE GRIS 1/2"
14	0233043	SCHLAUCHKLEMME 12 - 22	HOSE CLAMP 12 - 22	PINCE/TUYAU SOUPLE 12 - 22
15	0336001	HUTMUTTER DIN 1587 - M 4	CAP NUT DIN 1587 - M 4	ECROU BORGNE DIN 1587 - M 4
16	* 0401030	O-RING 50 X 1,5	O-RING 50 X 1,5	BAGUE O 50 X 1,5
17	0620443	DREHARMLAGER K 396	ROTATING ARM BUSHING K 396	PALIER DE BRAS ROTATIF K 396
18	0620381	ZENTRIERSTERN 180 LANG	CENTERING DEVICE STAR 180 LONG	ETOILE DE CENTRAGE 180 LONG
19	0620389	NACHSPÜLARM 1, LANG, K 307	FINAL RINSE ARM 1, LONG K 307	BRAS DE RINÇAGE FINAL 1 LONG K 307
	0620390	NACHSPÜLARM 2, MITTEL K 308	FINAL RINSE ARM 2, MEDIUM K 308	BRAS DE RINÇAGE FINAL 2 MEDIUM, K 308
20	V 0620121	DRALLEINSATZ K 121	TWISTING FLAT K 121	AILETTE K 121
21	V 0620157	NACHSPÜLDÜSENKAPPE K 157	CAP K 157 FOR RINSE NOZZLE	CAPUCHON K 157 POUR GICLEUR DE RINÇAGE
22	* 0620380	DREHARMNABE K 300	ROTATING ARM HUB K 300	MOYEU DE BRAS ROTATIF K 300
23	V 0310010	RÄNDELSCHRAUBE	KNURLED SCREW	VIS MOLETEE
24	* 0620384	SCHRAUBKAPPE K 302	SCREW CAP K 302	CAPUCHON VISSE K 302
25	0233070	1-OHR-KLEMME	1-EAR CLAMP	BORNE A UNE OREILLE
	8001814	WASCHARM OBEN/UNTEN, BAUGRUPPE	UPPER/LOWER WASH ARM BLOCK	BRAS ROTATIF SUP./INF. BLOC
	8004470	DREHARMLAGER UNTEN BAUGRUPPE	LOWER ROTATING ARM BUSHING BLOCK	PALIER DE BRAS ROTATIF INF. BLOC
26	0401065	O-RING 84 X 2	O-RING 84 X 2	BAGUE O 84 X 2

Зип Общежит

vsezip.ru

+7(812)987-08-81

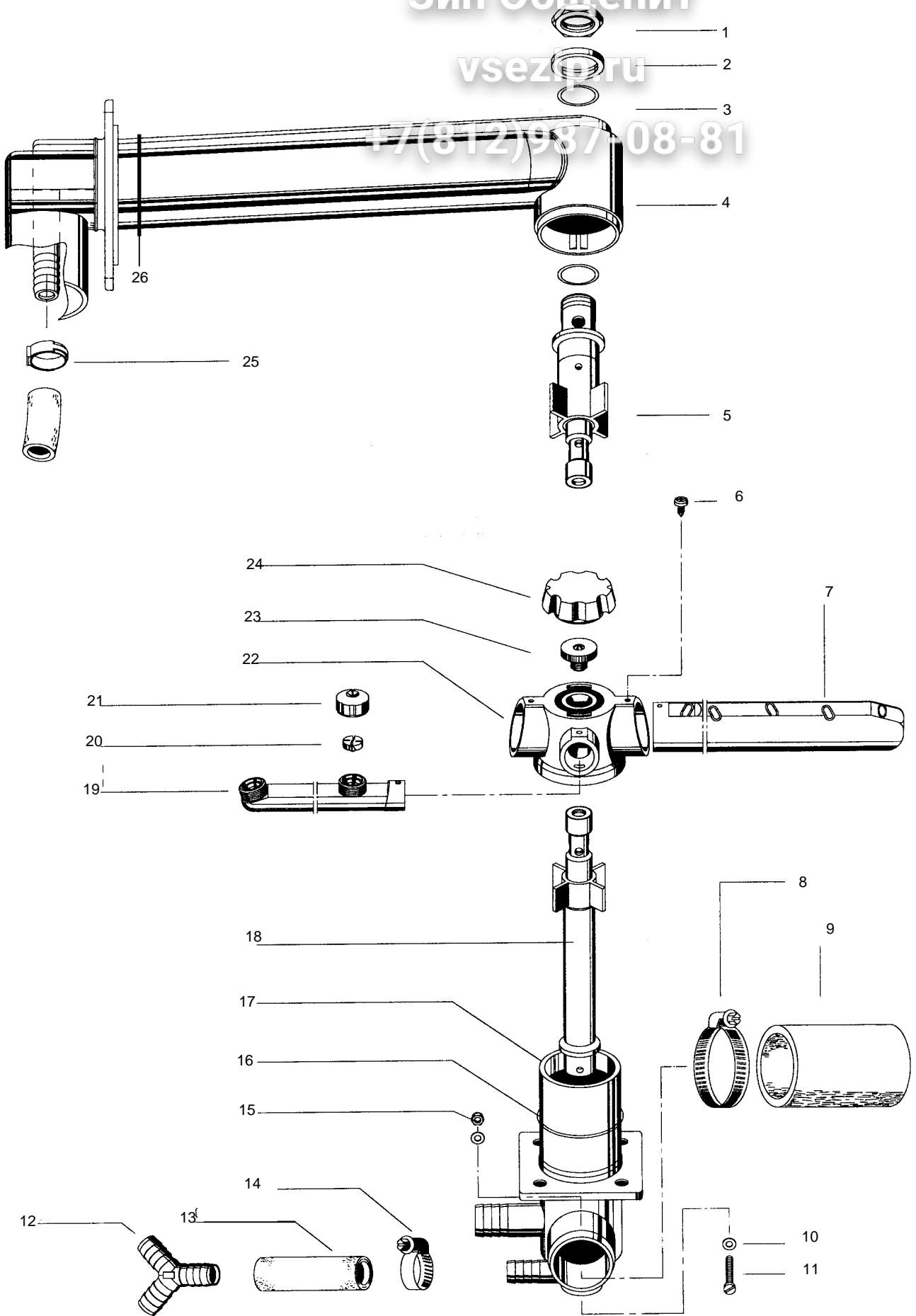

04.08 MAGNETVENTIL

04.08 SOLENOID VALVE

04.08 ELECTROVANNE

+7(812)987-08-81

Optional für Niederlande / optional for Netherlands / option pour les pays-bas

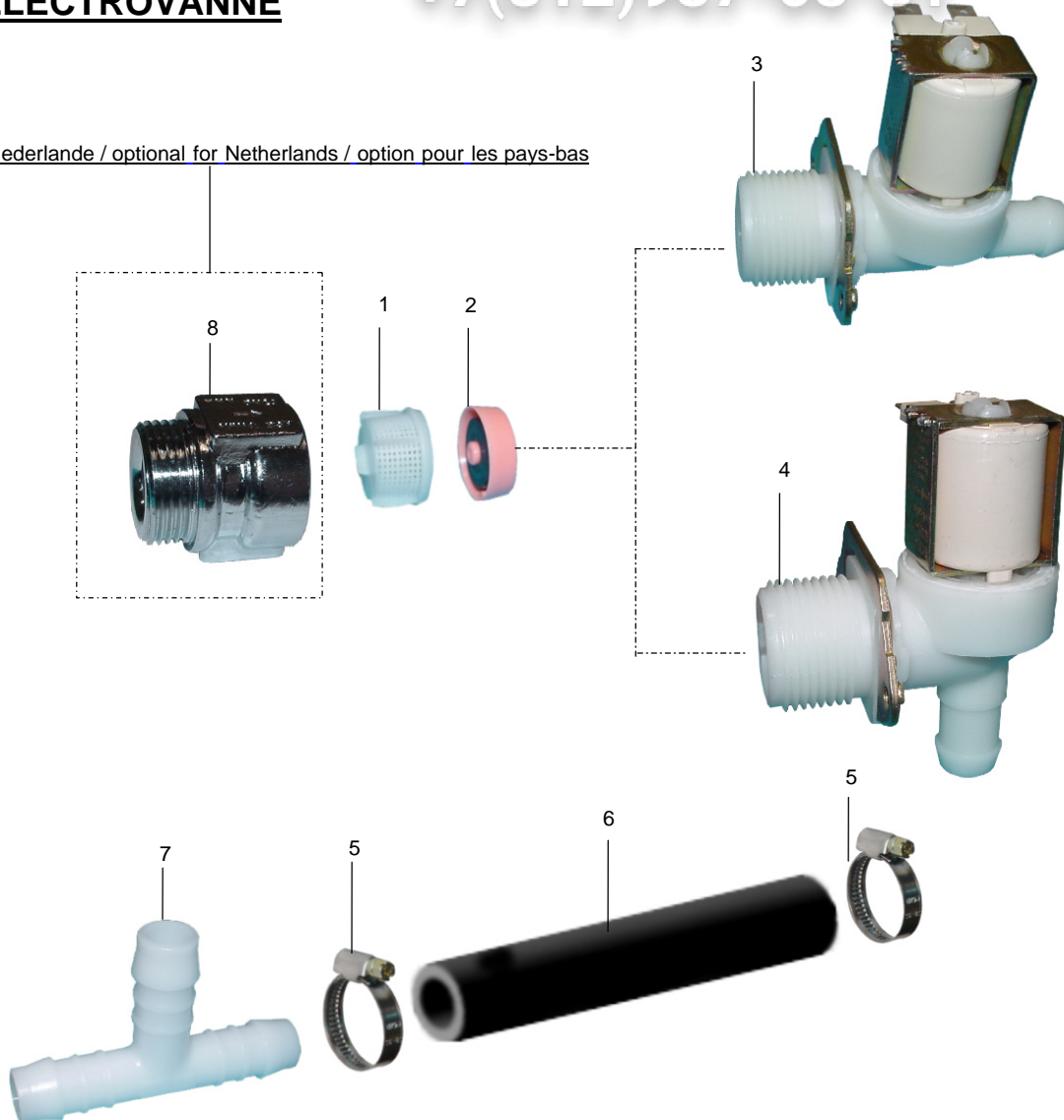

POS	IDENT. NR. IDENT. NO.	BEZEICHNUNG	DESIGNATION	DESIGNATION
1	0113098	MAGNETVENTILFILTERSIEB	FILTER SIEVE F. SOLENOID VALVE	TAMIS-FILTRE P. ELECTROVANNE
2	9506227	MENGENREGLER 17 L/ MIN.	QUANTITY REGULATOR 17 L/MIN	REGULATEUR DE QUANTITE 17 L/MIN
3	* 9505869	MAGNETVENTIL NW 10 GERADE AUSFÜHRUNG ECOSTAR 530 F / 545 D / FV 130 B	SOLENOID VALVE NW 10 LINEAR EXECUTION ECOSTAR 530 F / 545 D / FV 130 B	ELECTROVANNE NW 10 EXÉCUTION LINÉAIRE ECOSTAR 530 F / 545 D / FV 130 B
4	* 9541819	MAGNETVENTIL NW 10 ECKAUSFÜHRUNG	SOLENOID VALVE NW 10 ANGLED EXECUTION	ELECTROVANNE NW 10 EXECUTION EN ANGLE
5	* 0233043	SCHLAUCHKLEMME 12 - 22	HOSE CLAMP 12 - 22	PINCE/TUYAU SOUPLE 12 - 22
6	* 9608600	SCHLAUCH 1/2"	HOSE 1/2"	TUYAU FLEXIBLE 1/2"
7	0621035	T-STÜCK TS 13	T-PIECE TS 13	PIECE DE T TS 13
		OPTIONAL FÜR NIEDERLANDE	OPTIONAL FOR NETHERLANDS	OPTION POUR LES PAYS-BAS
7	9500454	RÜCKSCHLAGVENTIL 3/4"A X 3/4"l	CHECK VALVE 3/4"A X 3/4"l	CLAPET ANTI-RETOUR 3/4"A X 3/4"l

5.1 RÜCKSAUGEVERHINDERER

5.1 REFLUX PREVENTOR

5.1 DISPOSITIF ANTI-RETOUR +7(812)987-08-81

POS	IDENT. NR. IDENT. NO.	BEZEICHNUNG	DESIGNATION	DESIGNATION
1	8002731	RÜCKSAUGEVERHINDERER 1/2" KPL. (OHNE EW)	REFLUX PREVENTOR 1/2" COMPL. (WITHOUT EW)	DISPOSITIF ANTI-RETOUR 1/2" COMPL. (SANS EW)
2	8002732	RÜCKSAUGEVERHINDERER 1/2" KPL. (MIT EW)	REFLUX PREVENTOR 1/2" COMPL. (WITH EW)	DISPOSITIF ANTI-RETOUR 1/2" COMPL. (AVEC EW)
3	* 0620334	RÜCKSAUGEVERHINDERER K 333	REFLUX PREVENTOR K 333	DISPOSITIF ANTI-RETOUR K 333
4	0340027	UNTERLEGSCHIBE DIN 522 - 5,8 X 11 X 1	WASHER DIN 522 - 5,8 X 11 X 1	RONDELLE DIN 522 - 5,8 X 11 X 1
5	0337001	SECHSKANTMUTTER SELBST- SICHERND DIN 985 - M 5	HEXAGON NUT SELFFIXING DIN 985 - M 5	ECROU A SIX PANS INDESSERRABLE DIN 985 - M 5
6	0640012	SCHLAUCH GRAU 1/2"	HOSE GREY 1/2"	TUYAU FLEXIBLE GRIS 1/2"
7	0233070	1-OHR-KLEMME	1-EAR CLAMP	BORNE A UNE OREILLE
8	* 0620342	SCHLAUCHANSCHLUSS EINFACH K 340	HOSE CONNECTION SIMPLE K 340	CONNEXION DE TUYAU SIMPLE K 340
9	* 0620343	SCHLAUCHANSCHLUSS DOPPELT K 341 (MIT EW)	HOSE CONNECTION DOUBLE K 340 (WITH EW)	CONNEXION DE TUYAU DOUBLE K 340 (AVEC EW)
10	* 0217433	GUMMIDICHTUNG 17 X 24 X 2	RUBBER PACKING 17 X 24 X 2	JOINT EN CAOUTCHOUC 17 X 24 X 2
11	0360211	SECHSKANTMUTTER R 3/8" X 5	HEXAGON NUT R 3/8" X 5	ECROU A SIX PANS R 3/8" X 5

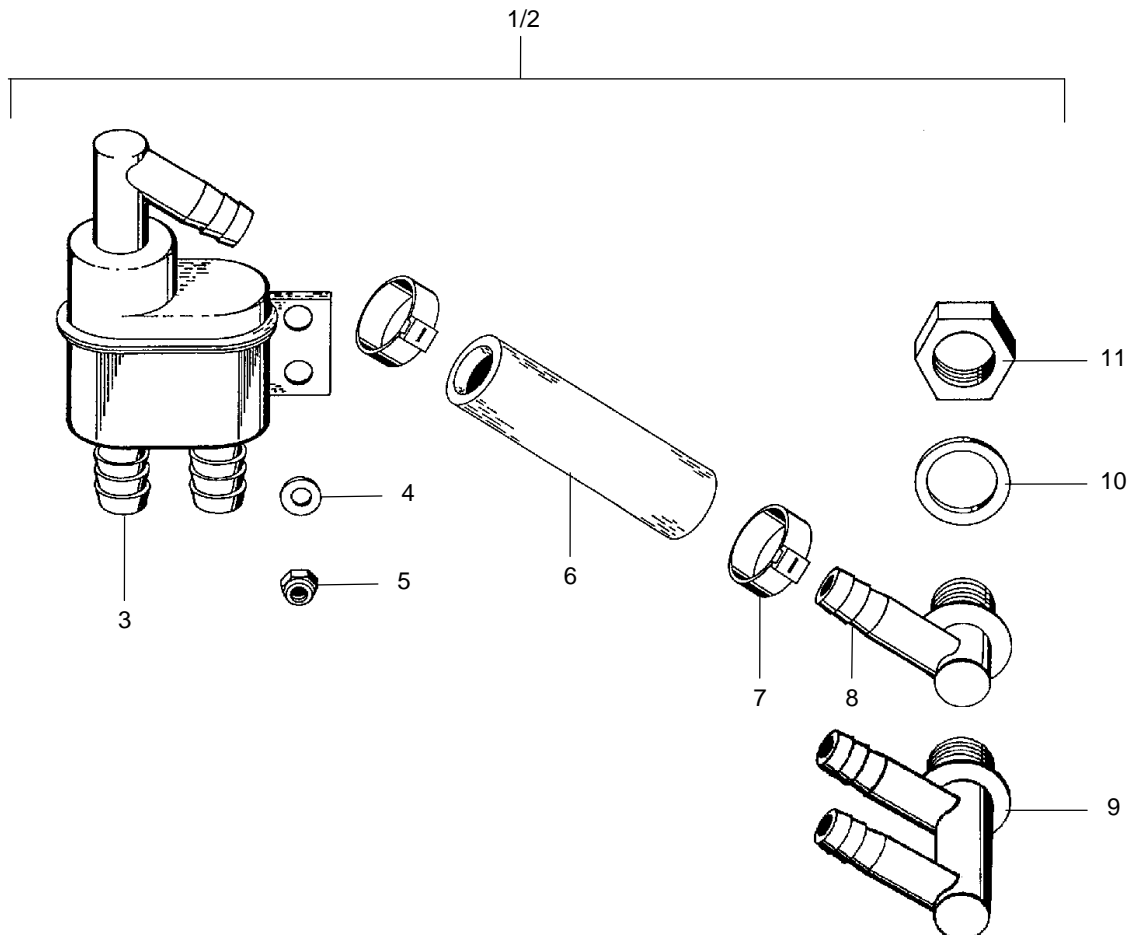

06.04 NIVEAUREGELUNG

06.04 LEVEL CONTROL

06.04 REGULATION DE NIVEAU

+7(812)987-08-81

POS	IDENT. NR. IDENT. NO.	BEZEICHNUNG	DESIGNATION	DESIGNATION
1	* 0130027	NIVEAUSCHALTER 90/25	LEVEL SWITCH 90/25	INTERRUPTEUR DE NIVEAU 90/25
2	* 9500044	DRAHTSCHLAUCHKLEMME SILBER 7,8-8,3 MM	HOSE WIRE CLAMP SILVER 7,8-8,3 MM	COLLIER DE SERRAGE ARGENT 7,8-8,3 MM
3	* 0260006	SCHLAUCH KLARSICHT 5 X 1,5	HOSE TRANSPARENT 5 X 1,5	TUYAU TRANSPARENT 5 X 1,5
4	0431028	KNICKSICHERUNGSFEDER	SAFETY SPRING	RESSORT DE SECURITE
5	* 9500045	DRAHTSCHLAUCHKLEMME GELB 8,8-9,3 MM	HOSE WIRE CLAMP YELLOW 8,8-9,3 MM	COLLIER DE SERRAGE JAUNE 8,8-9,3 MM
6	* 0233082	1-OHR-KLEMME 19,5 RER	1-EAR CLAMP 19,5 RER	BORNE A UNE OREILLE 19,5 RER
7	* 0650001	GUMMISTUTZEN	RUBBER SOCKET	MANCHON EN CAOUTCHOUC
8	* 0620244	LUFTFALLE K 244	AIR TRAP K 244	CHAMBRE DE COMPRESS. K 244

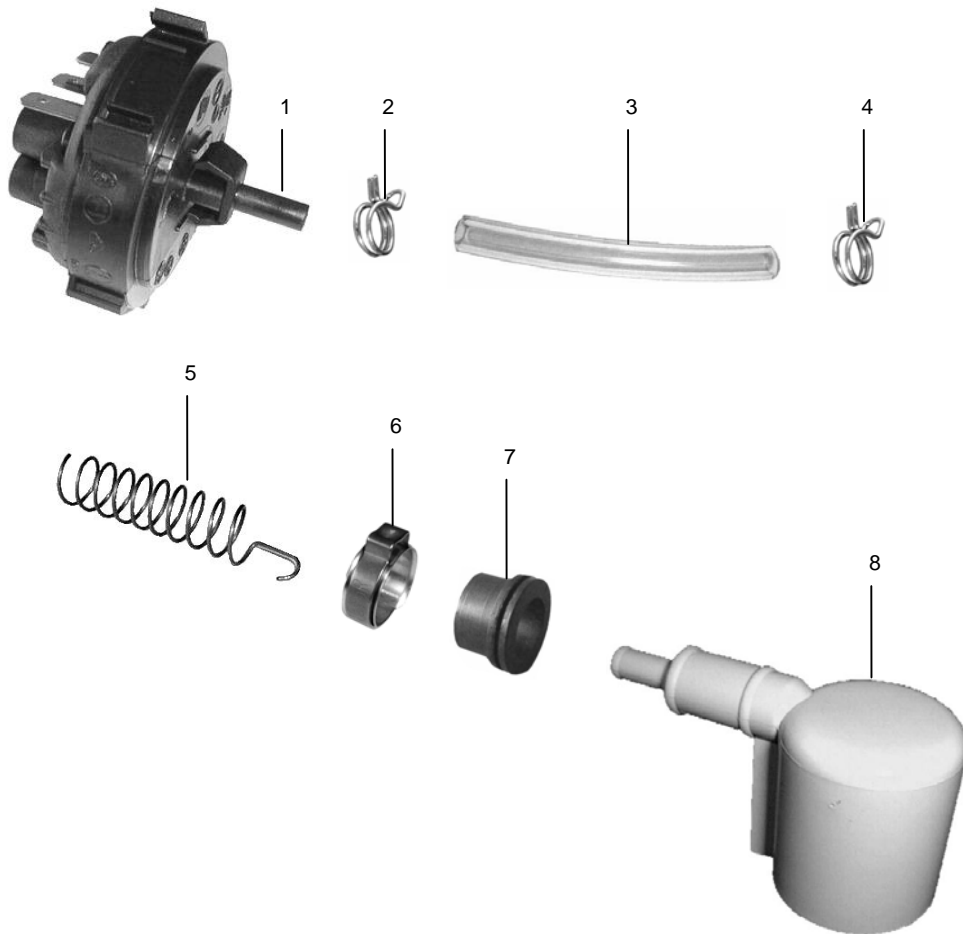

8.9 EINBAUBOILER

8.9 INCORPORATED BOILER

8.9 SURCHAUFFEUR INCORPORE

Зип Общепит

vsezip.ru



DV40N
01.06.98/FUS

+7(812)987-08-81

IDENT. NR. IDENT. NO.	BEZEICHNUNG	DESIGNATION	DESIGNATION
8400259	EINBAUBOILER KPL., 3 KW	INCORPORATED BOILER COMPL., 3 KW	SURCHAUFFEUR INCORPORE COMPL., 3 KW
8400260	EINBAUBOILER KPL., 6 KW	INCORPORATED BOILER COMPL., 6 KW	SURCHAUFFEUR INCORPORE COMPL., 6 KW
8400261	EINBAUBOILER KPL., 7,5 KW	INCORPORATED BOILER COMPL., 7,5 KW	SURCHAUFFEUR INCORPORE COMPL., 7,5 KW
8400229	EINBAUBOILER KPL., 9 KW	INCORPORATED BOILER COMPL., 9 KW	SURCHAUFFEUR INCORPORE COMPL., 9 KW
0302048	SECHSKANTSCHRAUBE DIN 933 - M 5 X 8	HEXAGON SCREW DIN 933 - M 5 X 8	VIS A SIX PANS DIN 933 - M 5 X 8
0342010	ZAHNSCHEIBE DIN 6797 - J 5,3	TOOTH LOCK WASHER DIN 6797 - J 5,3	DISQUE A FENTES DIN 6797 - J 5,3
0101183	SPANNBRÜCKE	GRIPPING YOKE	PONT DE TENSION
0308009	ZYLINDERSCHRAUBE DIN 84 - M4 X 6	PAN HEAD SCREW DIN 84 - M4 X 6	VIS A TETE CYLINDRIQUE DIN 84 - M4 X 6
* 0108037	TEMPERATURREGLER	THERMO CONTROL	REGULATEUR DE TEMPERATURE
* 0108039	TEMPERATURREGLER, 2 KONTAKTE	THERMO CONTROL, 2 CONTACTS	REGULATEUR DE TEMPERATURE, 2 CONTACTS
* 0101150	TOPFFLANSCHHEIZKÖRPER 3 KW, 230/400 V	FLANGE HEATING ELEMENT 3 KW, 230/400 V	RESISTANCE A BRIDE 3 KW, 230/400 V
* 0101143	TOPFFLANSCHHEIZKÖRPER 6 KW, 230/400 V	FLANGE HEATING ELEMENT 6 KW, 230/400 V	RESISTANCE A BRIDE 6 KW, 230/400 V
* 0101167	TOPFFLANSCHHEIZKÖRPER 7,5 KW, 230/400 V	FLANGE HEATING ELEMENT 7,5 KW, 230/400 V	RESISTANCE A BRIDE 7,5 KW, 230/400 V
* 0101166	TOPFFLANSCHHEIZKÖRPER 9 KW, 230/400 V	FLANGE HEATING ELEMENT 9 KW, 230/400 V	RESISTANCE A BRIDE 9 KW, 230/400 V
* 0101176	HEIZKÖRPERDICHTUNG 6 X 45 X 58	PACKING F.HEATING ELEMENT 6 X 45 X 58	JOINT DE RESISTANCE 6 X 45 X 58
0335000	SECHSKANTMUTTER DIN 934 - M3	HEXAGON NUT DIN 934 - M3	ECROU A SIX PANS DIN 934 - M3
* 0108038	TEMPERATURBEGRENZER 105 GRAD	TEMPERATURE LIMITER 105 DEGREES	LIMITEUR DE TEMPERATURE 105 DEGRES
8400269	EINBAUBOILERGEHÄUSE, ABGEPRESST	BOILER HOUSING, TESTED UNDER PRESSURE	BOITE DE SURCHAUFFEUR VERIFIER SOUS PRESSION
* 0640012	SCHLAUCH GRAU, 1/2"	HOSE GREY, 1/2"	TUYAU FLEXIBLE GRIS, 1/2"
* 0233037	SCHLAUCHKLEMME 16 - 27	HOSE CLAMP 16 - 27	PINCE/TUYAUX SOUPLES 16-27
* 0408008	DICHTUNG 25 X 14 X 1,5	PACKING 25 X 14 X 1,5	JOINT 25 X 14 X 1,5
0360202	SCHLAUCHANSCHLUSS	HOSE CONNECTION	CONNEXION DE TUYAUX
0233070	1-OHR-KLEMME	1-EAR CLAMP	BORNE A UNE OREILLE
0620373	SCHLAUCHANSCHLUSSWINKEL K 368	HOSE CONNECTION ANGLE K 368	ANGLE DE CONNEXION DE TUYAUX K 368

Зип Общепит

vsezip.ru

+7(812)987-08-81

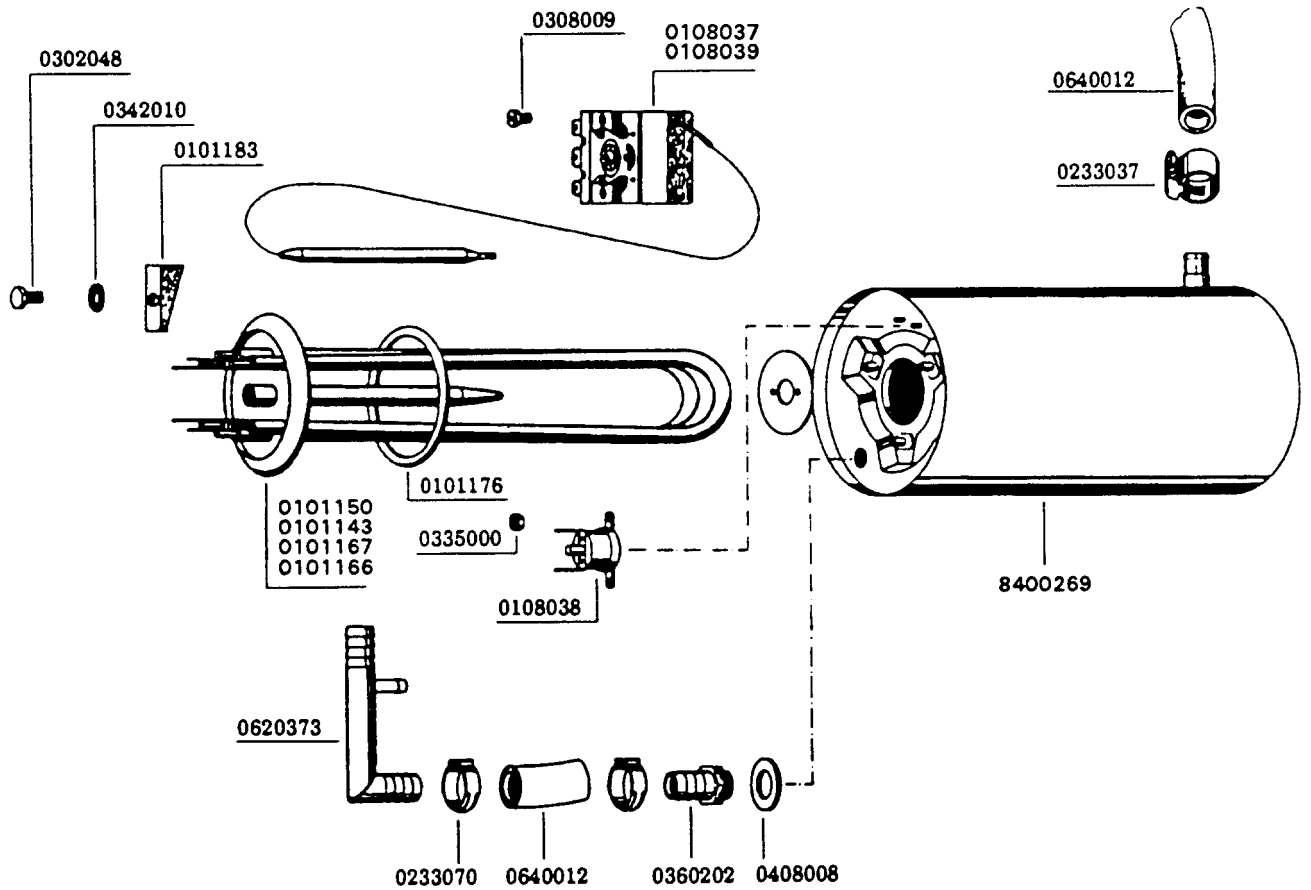

09.01 TANKHEIZUNG

09.01 TANK HEATING

09.01 CHAUFFAGE DE BAC

Зип Общепит

vsezip.ru

+7(812)987-08-81



DV40N
01.12.2000/FH

POS	IDENT. NR. IDENT. NO.	BEZEICHNUNG	DESIGNATION	DESIGNATION
1	* 0101152	HEIZKÖRPER 2 KW, 230 V	HEATING ELEMENT 2 KW, 230 V	RESISTANCE 2 KW, 230 V
2	* 0101175	HEIZKÖRPERDICHTUNG	HEATING ELEMENT PACKING	JOINT DE RESISTANCE
3	* 0108040	GUMMIMANSCHETTE	RUBBER PACKING	MANCHETTE EN CAOUTCHOUC
4	* 0108047	TEMPERATURREGLER 1 KONTAKT	THERMOSTAT 1 CONTACT	REGULATEUR DE TEMPERATURE 1 CONTACT
5	* 0108043	TEMPERATURBEGRENZER	TEMPERATURE LIMITER	LIMITEUR DE TEMPERATURE
6	* 0108053	TEMPERATURFÜHLER	TEMPERATURE PROBE	SONDE DE TEMPERATURE

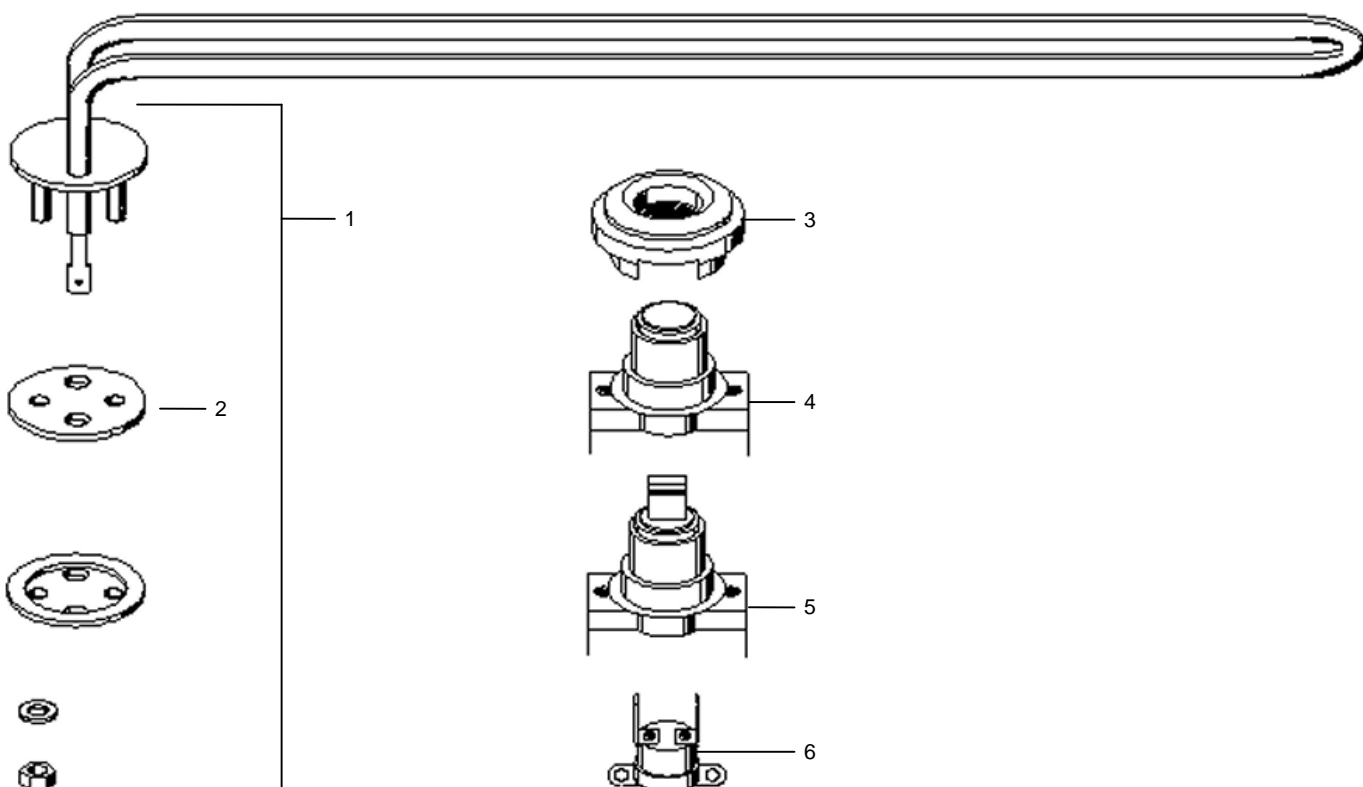

10.5 KLARSPÜLERDOSIERGERÄT

Зип Общепит

10.5 RINSE AID DOSING UNIT

vsezip.ru



DV40N
01.05.2001/FUS

10.5 DOSEUR DE PRODUIT TENSIO-ACTIF

7(812)987-08-81

POS	IDENT. NR. IDENT. NO.	BEZEICHNUNG	DESIGNATION	DESIGNATION
1	* 0260070	KLARSPÜLERDOSIERGERÄT N 6	RINSE AID DOSING UNIT N 6	DOSEUR DE PRODUIT TENSIO- ACTIF N 6
2	0260071	BEFESTIGUNGSLASCHE	FIXING LINK	COLLIER DE FIXATION
3	0260072	SCHRAUBE EJOT-PT KB 40 X 8	SCREW EJOT-PT KB 40 X 8	VIS EJOT-PT KB 40 X 8
4	* 0260049	EINSCHRAUBWINKEL M 10 X 1	INSERT ANGLE M 10 X 1	COUDE M 10 X 1
5	0233036	SCHLAUCHKLEMME 10 - 16	HOSE CLAMP 10 - 16	PINCE/TUYAUX SOUPLES 10 - 16
6	0640017	SCHLAUCH SCHWARZ 6 X 4,5	HOSE BLACK 6 X 4,5	TUYAU NOIR 6 X 4,5
7	0260052	DRUCKANSCHLUSS M 10 X 1	DELIVERY CONNECTION M 10 X 1	RACCORD DE REFOULEMENT M 10 X 1
8	* 0260051	O-RING 16 X 2	O-RING 16 X 2	BAGUE O 16 X 2
9	* 0260053	O-RING 8 X 2	O-RING 8 X 2	BAGUE O 8 X 2
10	0175006	SCHLAUCHKLEMME 9 - 10	HOSE CLAMP 9 - 10	PINCE/TUYAUX SOUPLES 9 - 10
11	V 0260007	SCHLAUCH KLARSICHT 6 X 1,5	HOSE TRANSPARENT 6 X 1,5	TUYAU TRANSPARENT 6 X 1,5
12	* 0113098	MAGNETVENTILFILTERSIEB	FILTER FOR SOLENOID VALVE	TAMIS-FILTRE D'ELECTROVANNE
13	8003830	KLARSPÜLERBEHÄLTER K 376	RINSE AID CONTAINER K 376	CONTENEUR DE PRODUIT TENSIO-ACTIF K 376
14	0233078	1-OHR-KLEMME 10,0 RER	1-EAR CLAMP 10,0 RER	BORNE A UNE OREILLE 10,0 RER
15	* 0260090	KORBFILTER	BASKET FILTER	PANIER FILTRE

Dos10_5a

Зип Общепит

vsezip.ru

+7(812)987-08-81

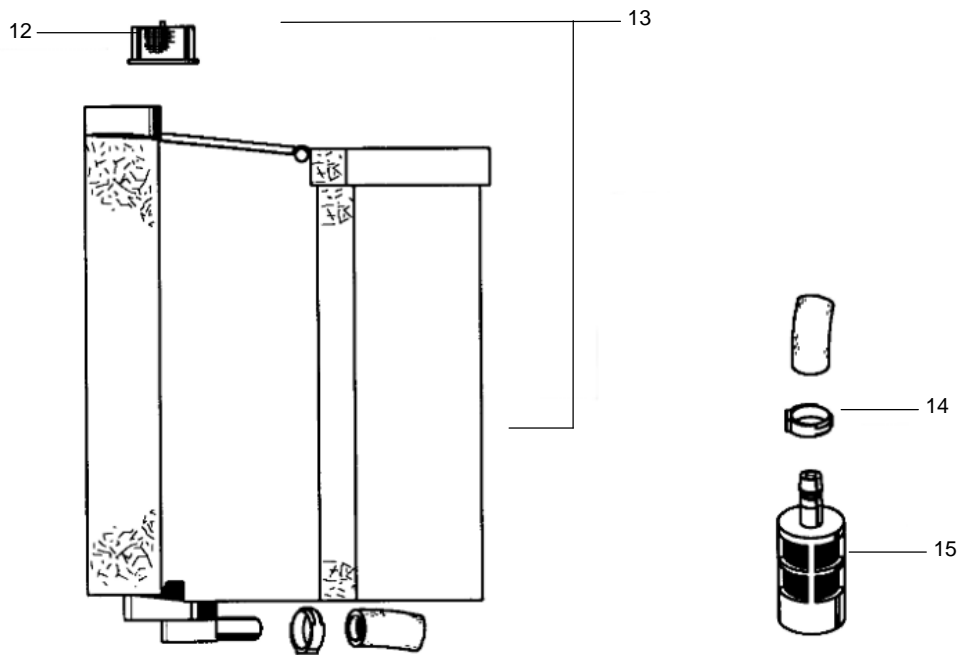
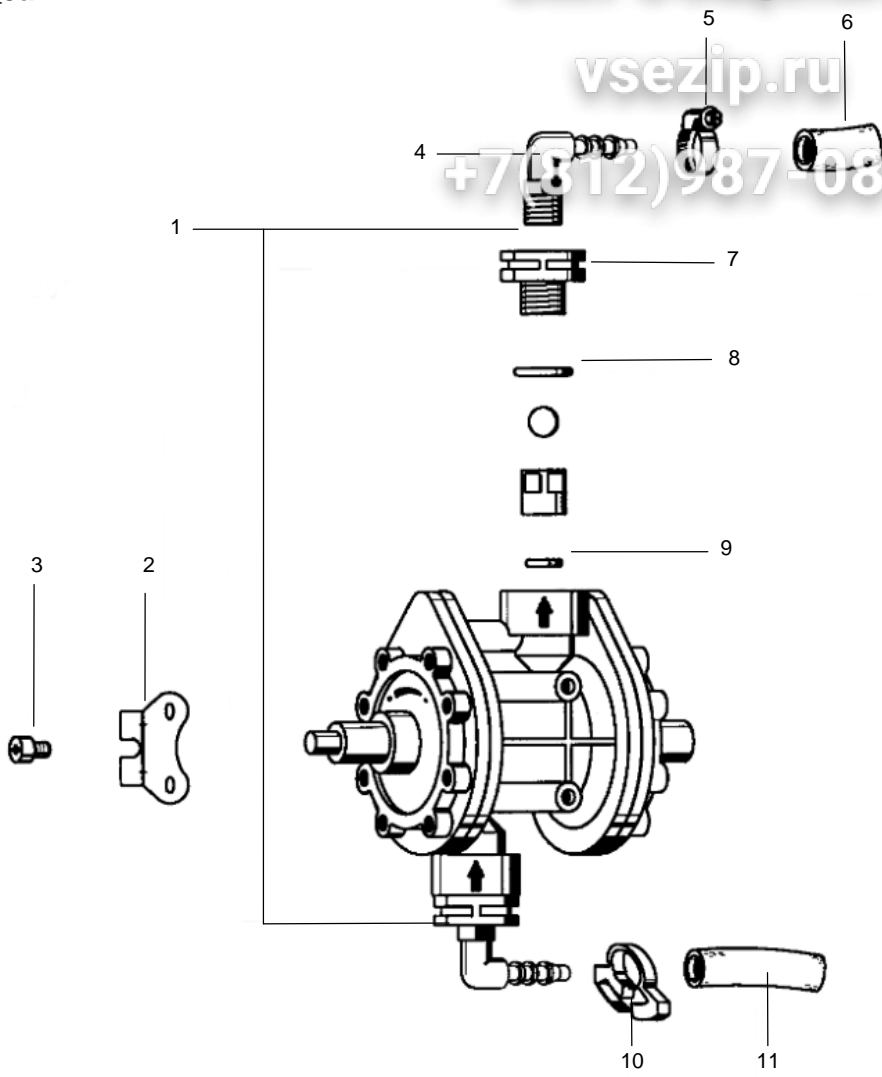

11.21 ELEKTRONIKSTEUERUNG

3ип Общепит

11.21 ELECTRONIC CONTROL

vsezip.ru

11.21 COMMANDE DE ELECTRONIQUE

+7(812)987-08-81



DV40Na
17/06/02/BP

POS	IDENT. NR. IDENT. NO.	BEZEICHNUNG	DESIGNATION	DESIGNATION
1	* 0467221	FOLIENSTASTATUR SPÜL 3	SENSOR TOUCH PANEL SPUEL 3	CLAVIER SENSITIF SPUEL 3
2	0124129	PLATINENHALTERUNG	HOLDER FOR CONTROL BOARD	SUPPORT POUR PLATINE A COMMANDE
3	0308003	ZYLINDERSCHRAUBE DIN 84 - M 3 X 10	PAN HEAD SCREW DIN 84 - M 3 X 10	VIS A TETE CYLINDRIQUE DIN 84 - M 3 X 10
4	0175550	ABSTANDSHALTER	SPREADER	ECARTEUR
5	* 0124187	STEUERPLATINE SPÜL 3 (MIT LP)	CONTROL BOARD SPUEL 3 (WITH DRAIN PUMP)	PLATINE A COMMANDE SPUEL 3 (AVEC POMPE DE VIDANGE)
6	* 0122106	HEBEL	LEVER	LEVIER
7	* 0122105	MICROSCHALTER	MICROSWITCH	MICRORUPTEUR
8	* 0122070	MAGNETSCHALTER	MAGNET SWITCH	INTERRUPTEUR MAGNETIQUE
9	* 0124225	RECHNER SPÜL 3, P 24/5	CHIP SPUEL 3, P 24/5	MICROPROCESSEUR SPUEL 3, P 24/5
	* 0124231	RECHNER SPÜL 3, P 30/5	CHIP SPUEL 3, P 30/5	MICROPROCESSEUR SPUEL 3, P 30/5
	* 0124233	RECHNER SPÜL 3, P 32/5	CHIP SPUEL 3, P 32/5	MICROPROCESSEUR SPUEL 3, P 32/5
	* 9500255	RECHNER SPÜL 3, P 54/5	CHIP SPUEL 3, P 54/5	MICROPROCESSEUR SPUEL 3, P 54/5
10	* 0180502	FLACHBANDKABEL M. STECKER 10 POL. 0,8 M	RIBBON CABLE WITH PLUG 10 POL. 0,8 M	CABLE PLAT AVEC FICHE 10 POL. 0,8 M
11	* 0124186	DIODENPLATINE SAP 3	DIODE CIRCUIT BOARD SAP 3	PLATINE A DIODES SAP 3

Зип Оффепит

vsezip.ru

+7(812)987-08-81

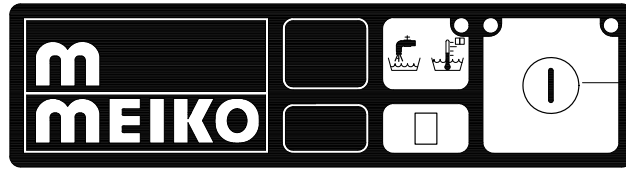

11

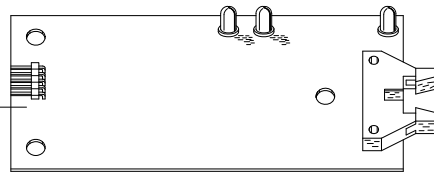

2

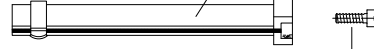

3



4



10

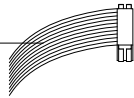

9

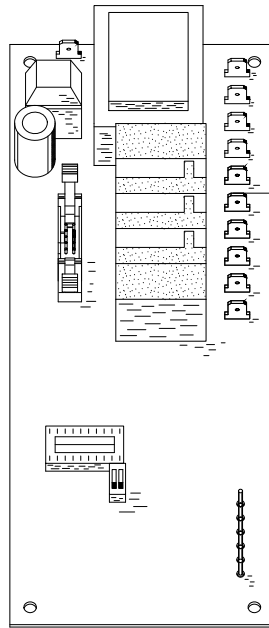

5

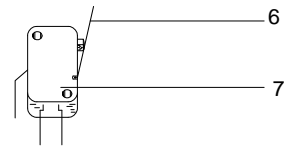

6

7

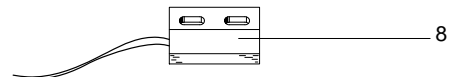

8

12.7 ELEKTROTEILE

12.7 ELECTRICAL PARTS

12.7 PIECES ELECTRIQUES

Зип Общепит

vsezip.ru

+7(812)987-08-81



DV40N
17/06/02

POS	IDENT. NR. IDENT. NO.	BEZEICHNUNG	DESIGNATION	DESIGNATION
1	0153288	ENDHALTER	END HOLDER	SUPPORT FINAL
2	0153268	ENDPLATTE	END PLATE	PLAQUE D'EXTREMITÉ
3	0153270	KLEMME M 10/10, GRAU	TERMINAL M 10/10 N, GREY	BORNE M 10/10, GRIS
	0153266	KLEMME M 6/8 N, BLAU	TERMINAL M 6/8 N, BLUE	BORNE M 6/8 N, BLEU
4	0153267	KLEMME M 6/8 P, GELB/GRÜN	TERMINAL M 6/8 P YELLOW/GREEN	BORNE M 6/8 P, JAUNE/VERT
5	* 0145013	FEINSICHERUNG 4 A MITTELTRÄGE 5 X 20	FINE-WIRE FUSE 4 A TIME LAGGED 5 X 20	FUSIBLE P. FAIBLE INTENSITE 4A A ACTION RETARDEE 5 X 20
	* 0145000	FEINSICHERUNG 10 A MITTELTRÄGE 5 X 20	FINE-WIRE FUSE 10 A TIME LAGGED 5 X 20	FUSIBLE P. FAIBLE INTENSITE 10A A ACTION RETARDEE 5 X 20
6	0153118	SICHERUNGSKLEMME WSI 6	SAFETY CLAMP WSI 6	BORNE DE SECURITE WSI 6
7	* 0135209	SCHÜTZ B6-30-01 230 V 40/60 HZ	CONTACTOR B6-30-01 230 V 40/60 HZ	CONTACTEUR B6-30-01 230 V 40/60 CYCLES
8	* 0135202	SCHÜTZ B12-30-01 230 V 40/60 HZ	CONTACTOR B12-30-01 230 V 40/60 HZ	CONTACTEUR B12-30-01 230 V 40/60 CYCLES
9	0153289	ENDPLATTE FÜR DOPPELKLEMME	END PLATE FOR DOUBLE TERMINAL	PLAQUE D'EXTREMITÉ POUR BORNE DOUBLE
10	0153292	KLEMME M 4/6 D2 DOPPELT GRAU	TERMINAL M 4/6 D2 DOUBLE, GREY	BORNE M 4/6 D2 DOUBLE, GRIS
	0153294	KLEMME M 4/6 D1N DOPPELT BLAU, MIT BRÜCKE	TERMINAL M 4/6 D1N DOUBLE, BLUE, WITH BRIDGE	BORNE M 4/6 D1N DOUBLE, BLEU, AVEC PONT
11	0153278	KLEMME M 4/6 P GN/GE GELB/GRÜN	TERMINAL M 4/6P GN/GE YELLOW/GREEN	BORNE M 4/6P GN/GE JAUNE/VERT
	0530114	FREQUENZUMRICHTER	FREQUENCY CONVERTER	CONVERTISSEUR DE FREQUENCE

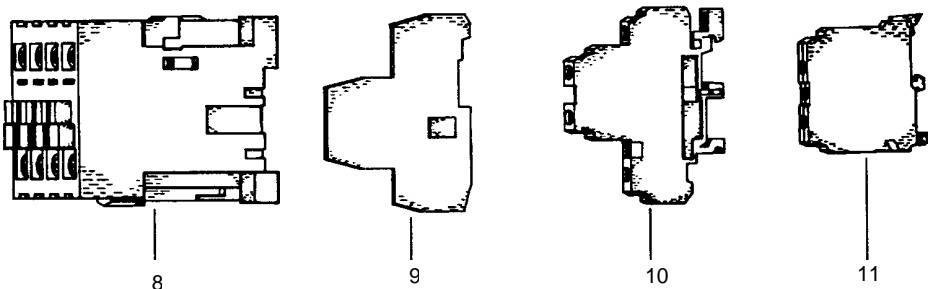
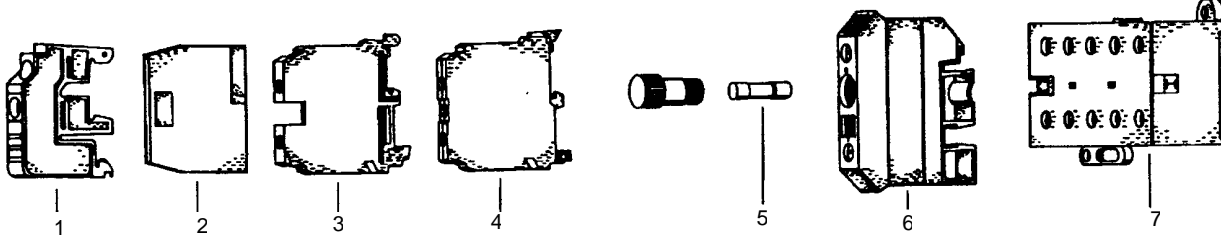

13.13 BAUGRUPPEN / EINZELTEILE**13.13 COMPONENT BLOCKS / PARTS****13.13 BLOCS / PIÈCES DETACHES**

Вип Общепит

vsezip.ru

DV40N
01.05.2001/FUS

+7(812)987-08-81

POS	IDENT. NR. IDENT. NO.	BEZEICHNUNG	DESIGNATION	DESIGNATION
	8004127	HAUBE KPL.	HOOD COMPL.	CAPOT COMPL.
	0463052	HAUBENFÜHRUNG RECHTS	HOOD ROD RIGHT HAND SIDE	BARRE DE CAPOT DROITE
	0463053	HAUBENFÜHRUNG LINKS	HOOD ROD LEFT HAND SIDE	BARRE DE CAPOT GAUCHE
	8004149	KORBTRÄGER KPL.	BASKET GUIDE RAIL COMPL.	SUPPORT DE PANIERS COMPL.
	8004406	TANKSIEB LINKS	TANK SIEVE LEFT HAND SIDE	TAMIS FILTRE GAUCHE
	0251102	TANKSIEB RECHTS	TANK SIEVE RIGHT HAND SIDE	TAMIS FILTRE DROITE
	8004467	SCHLIEßBLECH LINKS	STRIKE PLATE	TOLE DE FERMETURE
	8004141	SEITENVERKLEIDUNG	SIDE CLADDING	REVETEMENT LATERAL
	8004142	FRONTVERKLEIDUNG	FRONT CLADDING	REVETEMENT FRONTAL
	8004137	FEDERKASTENABDECKUNG	SPRING HOUSING COVER	RECOUVREMENT DE LA BOITE DES RESSORTS
	8004156	RÜCKWAND KPL.	REAR CLADDING COMPL.	REVETEMENT ARRIERE COMPL.
	0620455	ABSTANDHALTER FÜR VERKLEIDUNGEN	SPACER FOR CLADDING	E CARTEUR POUR REVETEMENT
	0621003	TISCHSTOLLEN K 220/221	TABLE LEGS K 220/221	PIEDS DE TABLE K 220/221
	0495440	UNIVERSALKORB VKV 50/1	UNIVERSAL BASKET VKV 50/1	PANIER UNIVERSEL VKV 50/1
	0495445	KLEINTEILEKORB VKV 50/2	BASKET FOR SMALL PIECES VKV 50/2	PANIER A PETITES PIECES VKV 50/2
	9647554	PANZERSCHLAUCH 1/2" X 2000	REINFORCED HOSE 1/2" X 2000	TUYEAU RENFORCÉ 1/2" X 2000
	9500011	PANZERSCHLAUCH 1/2" X 2000 WRC ZULASSUNG	REINFORCED HOSE 1/2" X 2000 WRC-APPROVED	TUYEAU RENFORCE 1/2" X 2000 CERTIFIE WRC

14.03 HAUBENGESTÄNGE

14.03 HOOD ROD

14.03 BARRE DE CAPOT

Зип Общепит

vsezip.ru



+7(812)987-08-81

POS	IDENT. NR. IDENT. NO.	BEZEICHNUNG	DESIGNATION	DESIGNATION
1	8004144	FEDERAUFHÄNGUNG OBEN	UPPER SPRING SUSPENDER	SUSPENDEUR DE RESSORT SUP.
2	V 0620445	GLEITLAGER FEDERAUF- HÄNGUNG K 399	SLIDING BUSHING FOR SPRING SUSPENSION K 399	PALIER-GLISSEUR POUR SUSP. DE RESSORT SUP. K 399
3	* 8001613	ZUGFEDER 372 X 46,5 X 6,5	TENSION SPRING 372 X 46,5 X 6,5	RESSORT DE TRACTION 372 X 46,5 X 6,5
4	* 8004425	SPANNSCHRAUBE M 8 760 LANG	TENSION SCREW M 8 760 LONG	VIS DE TENSION M 8 760 LONG
5	8004147	SPANNMUTTER M 8	TENSION NUT M 8	ECROU TENDEUR M 8
6	8004146	HAUBENGESTÄNGE DV 40/80/120 T, DV 40 N	HOOD ROD DV 40/80/120 T, DV 40 N	BARRE DE CAPOT DV 40/80/120 T, DV 40 N
7	V 0620449	LAGERUNG FÜR HAUBEN- GESTÄNGE	HOOD ROD BUSHING	COUSSINET POUR BARRE DE CAPOT
8	0337005	SECHSKANTMUTTER SELBST- SICHERND, DIN 985 - M 8	HEXAGON NUT SELFLOCKING DIN 985 - M 8	ECROU A SIX PANS, INDESSER- RABLE, DIN 985 - M 8
9	0340006	U-SCHIEBE 8,4 X 18 X 2	WASHER 8,4 X 18 X 2	RONDELLE 8,4 X 18 X 2
10	* 0620451	HAUBENROLLE K 409	HOOD ROLLER K 409	GALET DE CAPOT K 409
11	8000230	ROLLENBOLZEN SW 17 X 51 - M 8	ROLLER BOLT SW 17 X 51 - M 8	BOULON A ROULEAUX SW 17 X 51 - M 8
12	8004480	DECKEL FÜR HAUBENROLLE	HOOD ROLLER COVER	COUVERDE P. GALET DE CAPOT

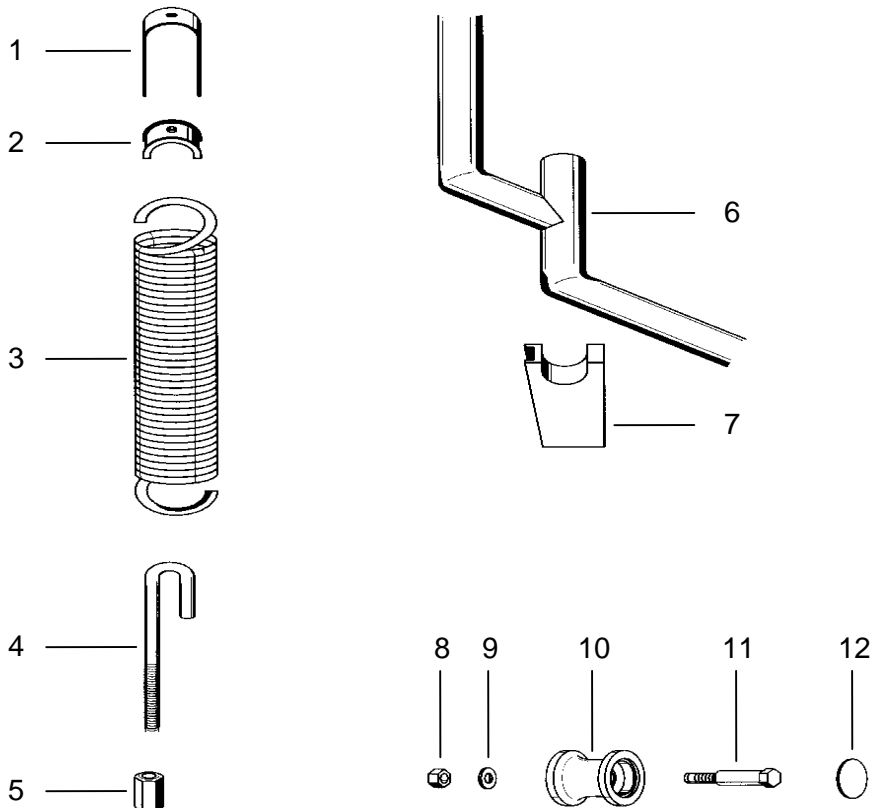

Das Programm auf einen Blick

1

**Spülautomaten mit stationärem
Waschverfahren**
Geschirr- und Gläserspülautomaten;
Topf- und Behälterspülautomaten;
Salat- und Gemüsewaschautomaten

2

Spülautomaten mit Durchlaufsystem
Geschirrspülautomaten mit Bandtransport-,
Korbtransport- oder Umlaufsystem

3

Spezialspülanlagen
Vollautomatische Spülanlagen für Geschirr,
Tablets und Besteck; Flight-Catering-
Anlagen; Industriespülautomaten; Trolley-,
Behälter- und Transportwagenspülanlagen

4

Förderanlagen
Tablett- und Geschirrtransportbänder,
Geschirrsortier- und Stapleinrichtungen

5

Speisereste-Behandlungsanlagen
Maschinen und Anlagen zur Aufbereitung
von Speiseresten für eine umweltgerechte
Entsorgung

6

Großkücheneinrichtungen
Geräte und Mobiliar für Relais- und Stations-
küchen; Transportwagen; Tablett- und Teller-
stapler; Tische, Schränke und Regale aus
Edelstahl; diverse Organisationsmittel

7

**Sanitäreinrichtungen für Krankenhäuser
und Heime**
Reinigungs- und Desinfektionsautomaten
für Steckbecken und andere Pflegegeschirre;
Pflegekombinationen; Komplettausstattung
für Unreine Arbeitsräume

Зип Ощепит

Our product
range vsezip.ru

Notre gamme
de production

+7(812)987-08-81

Automatic dishwashing machines
with fixed washing system

**Lave-vaisselle à procéder de lavage
stationnaire**
Automates de lavage

**Belt conveyor and rack transport
machines**
for continuous throughput operations

**Lave-vaisselle automatiques à passage
continu**
Lave-vaisselle automatiques à convoyeur et
à transport de paniers

Special purpose warewashing solutions
such as semi and fully automatic systems,
designed for the catering industry in general

Lave-vaisselle spéciaux
Installations de lavage entièrement
automatiques et semi-automatiques,
lave-vaisselle industriels

Conveying systems
for vertical and horizontal transport of trays
and dishes

Installations de transport
pour le transport vertical et horizontal de
plateaux

Food waste treatment systems
Water conditioning appliances

**Installations de traitement de déchets
alimentaires**
ainsi que des installations de traitement
d'eau

Central wash-up equipment
Tables, cabinets, tray and plate stackers

Installations pour grandes cuisines
Tables, empileurs de plateaux et d'assiettes

**Sanitary appliances for healthcare
establishments**
Automatic cleaning and disinfection
appliances for bedpans and other care
utensils

**Installations sanitaires pour hôpitaux et
maisons de soins**
Automates de nettoyage et de désinfection,
combinés de soins



MEIKO Maschinenbau GmbH & Co. KG
Englerstr. 3 · 77652 Offenburg · Germany
Tel. + 49 (0)781/203-0
Fax +49 (0)781/203-1274
e-mail: info@meiko.de · www.meiko.de

