

Зип Общепит

vsezip.ru

---

+7(812)987-08-81 DESPIECE TECNICO

---

**Lavavajillas de apertura frontal  
Lave-vaisselle à ouverture frontale  
Front loading dishwasher  
Geschirrspülmaschinen mit frontbeladung  
Lavastoviglie ad apertura frontale  
Lava-louças de apertura frontal**

**Modelos:**

**LABP-300**

**LABP-300 DD**

**LABP-300B BT**

**LABP-300 DD UK**

***Septiembre 2009 September***

*Revisado Abril 2012 April Revised*

**asber** 

Зип Общепит

ysezip.ru

7(812)987-08-8

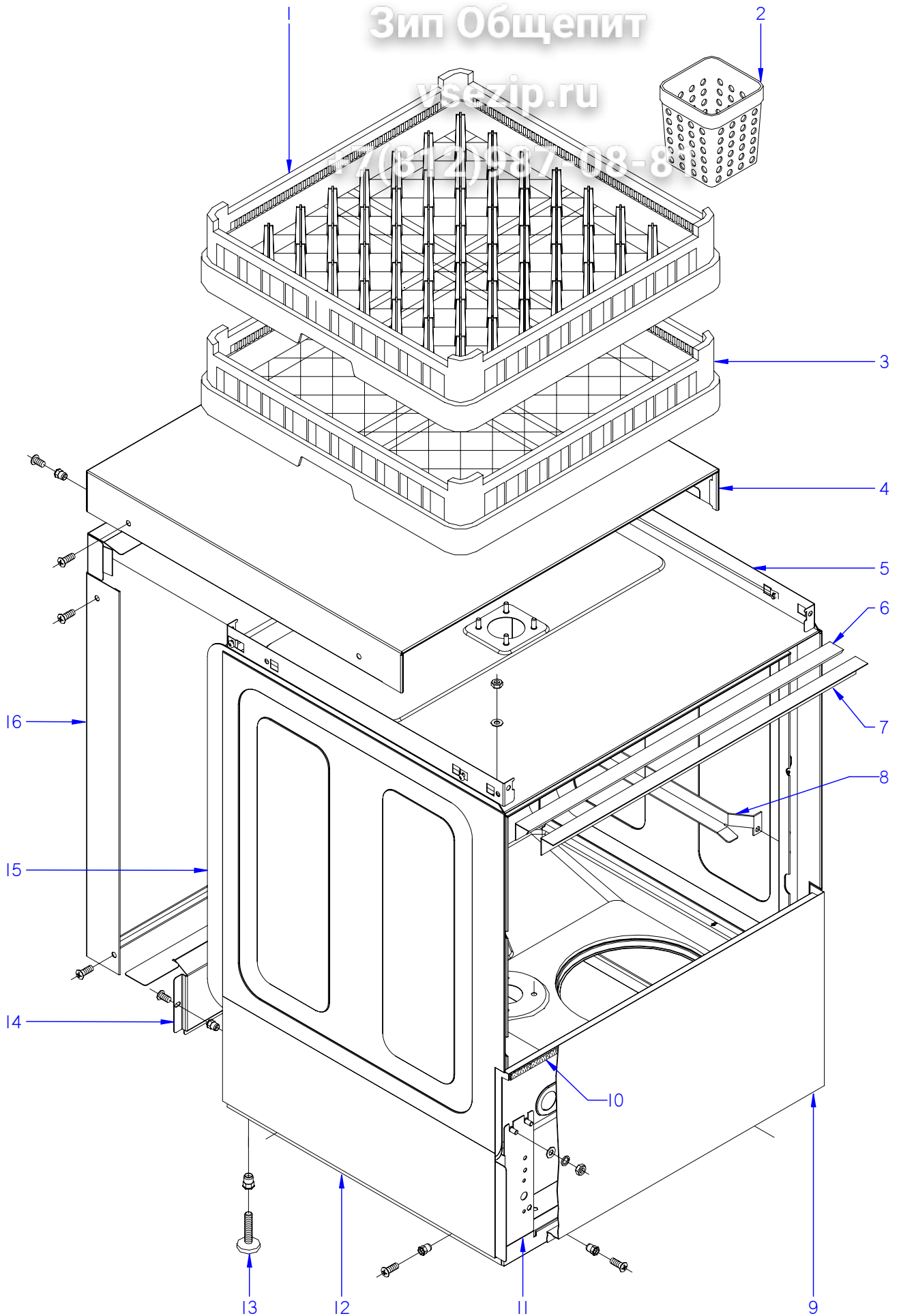

ITEM MARCADO EN COLOR = REPUESTO RECOMENDADO  
COLOURED ITEM = RECOMMENDED SPARE PART

N plano	Firma	Fecha	Aparato	MUEBLE	Lamina	
C-2610	<i>name Benfor</i>	2009-09	LAVAVAJILLAS LABP-300		1	asber 

MOD.	LAVAVAJILLAS DE APERTURA FRONTAL	ZONA	MUEBLE				
ITEM	CODIGO	DENOMINACION	TEXTO	LABP-300	LABP-300B BT	LABP-300 DD	LABP-300 DD UK
1	Z655302000	CESTILLO PLATOS CP-16-18	PLATE BASKET CP-16-18	1	1	1	1
2	Z655314000	CESTILLO CUBIERTOS	CUTLERY BASKET	1	1	1	1
3	Z655301000	CESTILLO BASE CT-10	BASE BASKET CT-10	1	1	1	1
	Z209121000	TOPE 50x50x80	BUFFER 50x50x80	2	2	2	2
4	Z202906000	TAPA T-CO.	COVER T-CO.	1	1	1	1
	Q221342000	REMACHE EXAGONAL M5	HEXAGONAL RIVET M5	2	2	2	2
	Q152004000	TORNIL, APLASTADO M5x13 A304	FLAT HEADED BOLT M5x13 A304	2	2	2	2
	Q152004000	TORNIL, APLASTADO M5x13 A304	FLAT HEADED BOLT M5x13 A304	4	4	4	4
	Q221012000	TUERCA RAPIDA M,5	RAPID NUT M,5	4	4	4	4
	3713500000	PERFIL CUBREARISTAS PLASTICO	PLASTIC EDGE COVER PROFILE	1	1	1	1
5	Z208736000	ESCUADRA AMARRE TAPA ASPES	COVER FASTENING BRACKET A	2	2	2	2
5	Z200329000	ESCUADRA AMARRE TAPA AF	COVER FASTENING BRACKET A	2	—	2	2
	Q012073000	TORNILLO EXAGONAL M12X20	WASHER A6	2	—	2	2
	Q306024000	JUNTA18X12.5X1.5	HEXAGONAL BOLT M12x20	2	2	2	2
	Q162070000	TUERCA EXAGONAL M12	HEXAGONAL NUT M12	2	2	2	2
	Q162040000	TUERCA EXAGONAL M6	HEXAGONAL NUT M6	4	4	4	4
6	Z200315000	PERFIL CAJA	BOX PROFILE	1	1	1	1
7	Z200309000	ESCUADRA SUJECCION PERFIL	FASTENING BRACKET PROFILE	1	1	1	1
8	Z200305000	GUIA CESTILLO DERECHO	RIGHT BASKET GUIDE	1	1	1	1
8	Z200347000	GUIA CESTILLO DERECHO	RIGHT BASKET GUIDE	1	1	1	1
	Q162040000	TUERCA EXAGONAL M6	HEXAGONAL NUT M6	4	4	4	4
	Q232040000	ARANDELA A6	WASHER A6	4	4	4	4
	Q306024000	JUNTA18X12.5X1.5	SEAL 18X12.5X1.5	1	1	1	1
	Q162070000	TUERCA EXAGONAL M12	HEXAGONAL NUT M12	1	1	1	1
S/Nº	Z200306000	GUIA CESTILLO IZQUIERDO	LEFT BASKET GUIDE	1	1	1	1
S/Nº	Z200348000	GUIA CESTILLO IZQUIERDO	LEFT BASKET GUIDE	1	1	1	1
9	Z202913000	PANEL FRONTAL SIN PUERTA	FRONT PANEL WITHOUT DOOR	1	—	1	1
9	Z228812000	PANEL FRONTAL B SIN PUERTA	FRONT PANEL B WITHOUT DOOR	—	1	—	—
	Q152004000	TORNIL, APLASTADO M5x13 A304	FLAT HEADED BOLT M5x13 A304	2	2	2	2
10	Z200313000	PERFIL GOMA ESPONJOSA	FOAM RUBBER PROFILE	1	1	1	1



Зип Общепит

vsezip.ru

+7(812)987-08-81

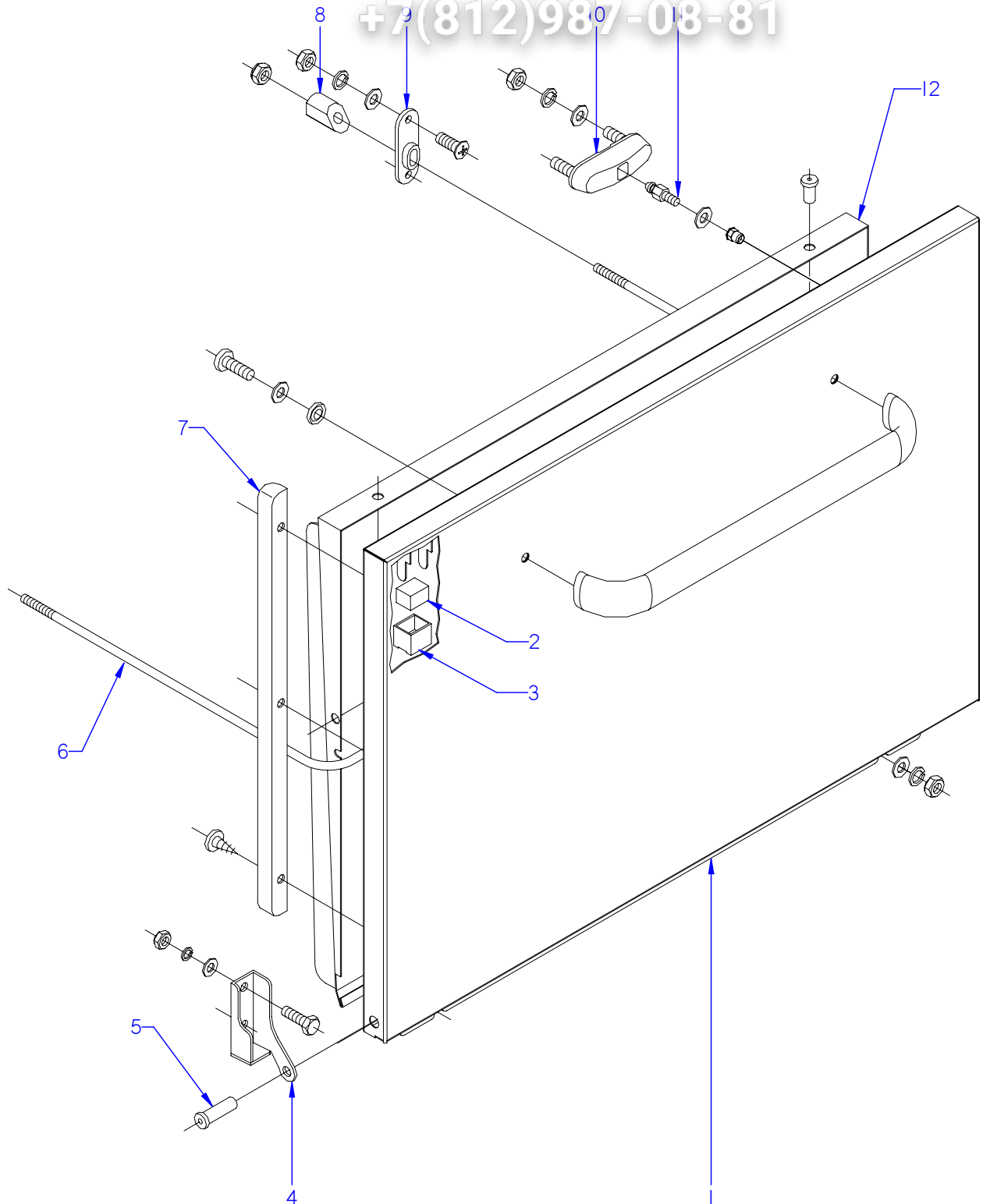

ITEM MARCADO EN COLOR = REPUESTO RECOMENDADO  
COLOURED ITEM = RECOMMENDED SPARE PART

N plano	Firma	Fecha	Aparato	PUERTA	Lamina	
C-2611	<i>[Signature]</i>	2009-09	LAVAVAJILLAS LABP-300		2	

MOD.		LAVAVAJILLAS DE APERTURA FRONTAL		ZONA	PUERTA			
ITEM	CODIGO	DENOMINACION	TEXTO	LABP-300	LABP-300B BT	LABP-300 DD	LABP-300 DD UK	
1	Z208740000	PUERTA COMPLETA	COMPLETE DOOR	1	1	1	1	
1	Z218005000	PUERTA SOLDADA	WELDED DOOR	1	1	1	1	
S/Nº	Z208619000	ASA AF NEGRA	BLACK HANDLE	1	1	1	1	
	Q032041000	TORNILLO ALOMADO M6X10	CURVED SCREW M6x10	2	2	2	2	
	Q308002000	ARANDELA DUBO A6 NYLON	WASHER DUBO A6 NYLON	2	2	2	2	
	Q232040000	ARANDELA PLANA INOX 6MM DIN12	WASHER STEELNOX 6MM DIN12	2	2	2	2	
2	Z200506000	IMAN	MAGNET	1	1	1	1	
3	Z200507000	PROTECTOR IMAN	MAGNET PROTECTOR	1	1	1	1	
4	Z400514000	BISAGRA IZQUIERDA T-C.	LEFT HINGE T-C.	1	1	1	1	
	Q012042000	TORNIL. EXAGONAL M6X15 A.304	HEXAGONAL BOLT M6X15 A.304	2	2	2	2	
	Q232040000	ARANDELA A6	WASHER A6	2	2	2	2	
	Q262040000	ARANDELA GROW. A6 A.304	WASHER GROW. A6 A.304	2	2	2	2	
	Q162040000	TUERCA EXAGONAL M6	HEXAGONAL NUT M6	1	1	1	1	
S/Nº	Z400515000	BISAGRA DERECHA T-C.	RIGHT HINGE T-C.	1	1	1	1	
	Q012042000	TORNIL. EXAGONAL M6X15 A.304	HEXAGONAL BOLT M6X15 A.304	2	2	2	2	
	Q232040000	ARANDELA A6	WASHER A6	2	2	2	2	
	Q262040000	ARANDELA GROW. A6 A.304	WASHER GROW. A6 A.304	2	2	2	2	
	Q162040000	TUERCA EXAGONAL M6	HEXAGONAL NUT M6	1	1	1	1	
5	Z400516000	EJE PUERTA	DOOR SHAFT	2	2	2	2	
6	Z200555000	VARILLA TENSOR	TENSIONING ROD	1	1	1	1	
7	Z200524000	MARCO PUERTA	DOOR FRAME	2	2	2	2	
	Q412000000	REMACHE TUBULAR 4 x 8	TUBULAR RIVET 4 x 8	6	6	6	6	
	Q012042000	TORNIL. EXAGONAL M6X15 A.304	HEXAGONAL BOLT M6X15 A.304	2	2	2	2	
8	Z200522000	TENSOR PUERTA	DOOR TENSOR	2	2	2	2	
	Q222012000	TUERCA AUTOB. M6	SELF-LOCK NUT M6	2	2	2	2	
9	Z200310000	SOPORTE TENSOR	TENSOR SUPPORT	2	2	2	2	
	Q162030000	TUERCA EXAGONAL M5	HEXAGONAL NUT M5	4	4	4	4	
	Q152004000	TORNIL, APLASTADO M5x13 A304	FLAT HEADED BOLT M5x13 A304	4	4	4	4	
	Q232030000	ARANDELA A5	WASHER A5	4	4	4	4	
	Q262030000	ARANDELA GROW. A5 A.304	WASHER GROW. A5 A.304	4	4	4	4	



Зип Общепит

vsezip.ru

+7(812)987-08-81

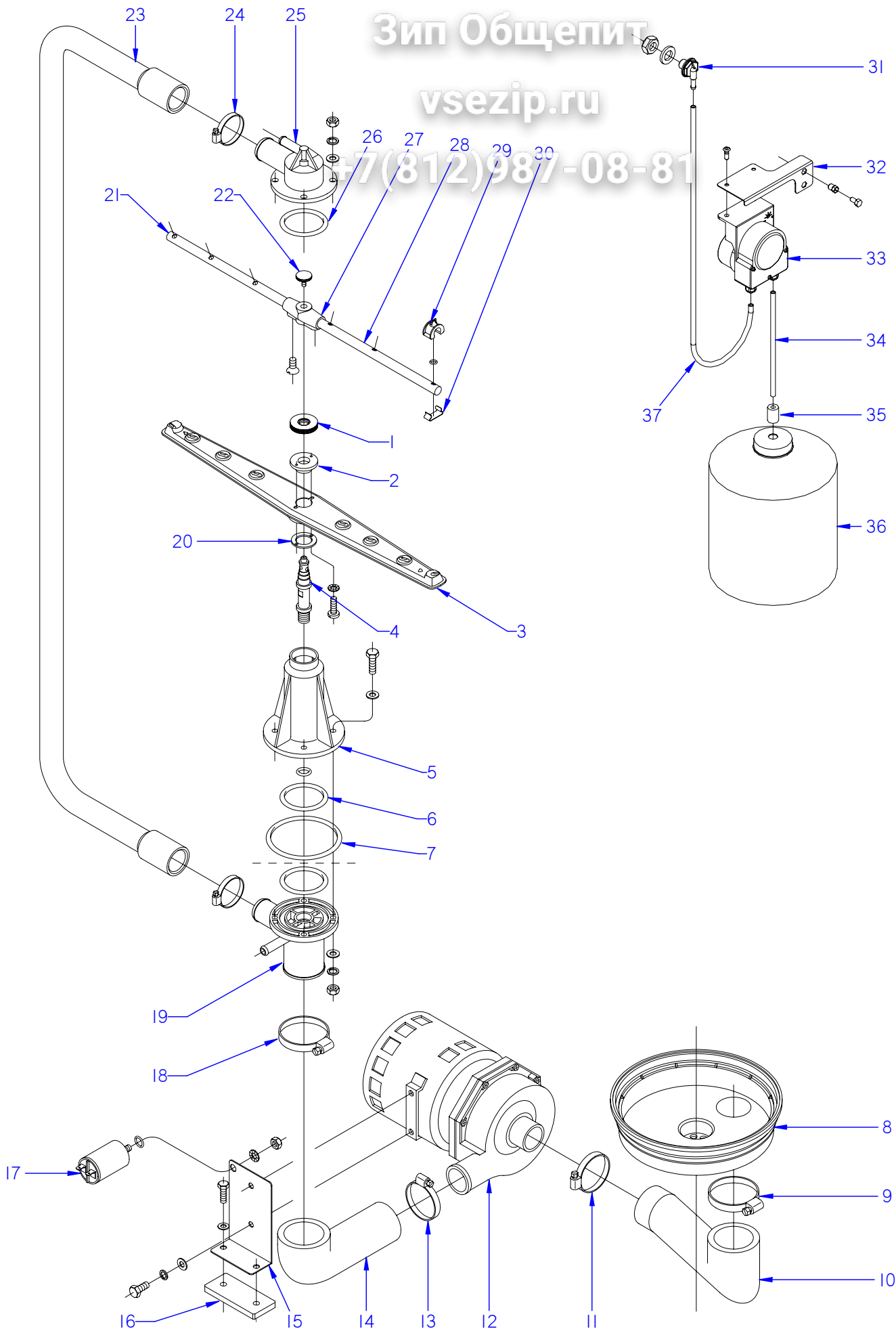

ITEM MARCADO EN COLOR = REPUESTO RECOMENDADO  
COLOURED ITEM = RECOMMENDED SPARE PART

N plano	Firma	Fecha	Aparato	CONJUNTO FUNCIONAL LAVADO	Lamina	
C-2612	<i>(Signature)</i>	2009-09	LAVAVAJILLAS LABP-300		3	



MOD.	LAVAVAJILLAS DE APERTURA FRONTAL	ZONA	CONJUNTO FUNCIONAL LAVADO				
ITEM	CODIGO	DENOMINACION	TEXTO	LABP-300	LABP-300B BT	LABP-300 DD	LABP-300 DD UK
1	Z200705000	TUERCA ESPECIAL M.14X1	SPECIAL NUT M.14X1	2	2	2	2
2	Z650704000	ENGANCHE DISTRIBUIDOR	DISTRIBUTOR HOOK	2	2	2	2
3	Z650716000	DISTRIBUIDOR MONTADO	DISTRIBUTOR MOUNTED	2	2	2	2
4	Z200704000	EJE CENTRAL	CENTRAL SHAFT	2	2	2	2
5	Z200701000	SOPORTE DISTRIBUID. INFERIOR	LOWER DISTRIBUTOR SUPPORT	1	1	1	1
	Q307050000	JUNTA TOR.13.94X19.18X2.6	O-RING 13.94X19.18X2.6	1	1	1	1
	Q012046000	TORNIL. EXAGONAL M6X40 A.304	HEXAGONAL BOLT M6X40 A.304	4	4	4	4
6	Z307052000	JUNTA TOR.50.17X60.83X5.3	O-RING 50.17X60.83X5.3	2	2	2	2
7	Q307049000	JUNTA TOR.85.09X95.75X5.3	O-RING 85.09X95.75X5.3	1	1	1	1
8	Z200906000	CUBETA	TRAY	1	1	1	1
9	Q881324000	ABRAZADERA 50-70L	CLAMP 50-70L	1	1	1	1
10	Z200904000	CODO ASPIRACION 1003018	EXTRACTOR ELBOW 1003018	1	1	1	1
11	Q881307000	ABRAZADERA 40-60	CLAMP 40-60	1	1	1	1
12	Z201011000	BOMBA DE LAVADO	WASH PUMP	1	1	1	1
12	Z203511000	BOMBA DE LAVADO 60 HZ.	WASH PUMP 60 Hz.	1	1	1	1
13	Q881307000	ABRAZADERA 40-60	CLAMP 40-60	1	1	1	1
14	Z200905000	CODO IMPULSION 1003017	IMPULSE ELBOW 1003017	1	1	1	1
15	Z201002000	SOPORTE MOTOBO.F-3-4-5-6	MOTORPUMP SUPPORT F-3-4-5-	1	1	1	1
16	Z201003000	BASE BOMBA LAVADO 1003016	WASH PUMP BASE 1003016	1	1	1	1
	Q012033000	TORNIL. EXAGONAL M5X20 A.304	HEXAGONAL BOLT M5X20 A.304	2	2	2	2
	Q232030000	ARANDELA A5	WASHER A5	2	2	2	2
17	V321300000	CONDENSADOR 10 M.F.	CONDENSER 10 M.F.	1	1	1	1
	Q307048000	JUNTA TORICA 9.12X16.18X3.53	O-RING 9.12x16.18x3.53	1	1	1	1
	Q162050000	TUERCA EXAGONAL M8x1 INOX.	HEXAGONAL NUT M8x1 INOX.	1	1	1	1
	Q261050000	ARANDELA MUELLE A8	SPRING WASHER A8	1	1	1	1
18	Q881324000	ABRAZADERA 50-70L	CLAMP 50-70L	1	1	1	1
19	Z200703000	PASAMUROS	BUSHING	1	1	1	1
	Q232040000	ARANDELA A6	WASHER A6	4	4	4	4
	Q262040000	ARANDELA GROW. A6 A.304	WASHER GROW. A6 A.304	4	4	4	4
	Q162040000	TUERCA EXAGONAL M6	HEXAGONAL NUT M6	4	4	4	4

MOD.	LAVAVAJILLAS DE APERTURA FRONTAL	ZONA	CONJUNTO FUNCIONAL LAVADO				
ITEM	CODIGO	DENOMINACION	TEXTO	LABP-300	LABP-300B BT	LABP-300 DD	LABP-300 DD UK
20	Z650711000	AMARRE ENGANCHE DISTRIBUID.	DISTRIBUTOR HOOK FASTENING	2	2	2	2
	Q152015000	TORNILLO ALOMADO M3X6	CURVED SCREW M3X6	4	4	4	4
	Q242010000	ARANDELA ABANICO A.3 A304	FAN WASHER A3 A304	4	4	4	4
21	Z208712000	RAMA DE ACLARADO IZQUIERDA	LEFT RINSE BRANCH	2	2	2	2
22	Q152016000	TORNILLO ESPECIAL M.5X0.8	SPECIAL BOLT M.5X0.8	2	2	2	2
23	Z200706000	ARBOL DE LAVADO	WASH CAM	1	1	1	1
24	Q881305000	ABRAZADERA 25-40	CLAMP 25-40	2	2	2	2
25	Z200707000	SOPORTE DISTRIBUIDOR SUPER.	UPPER DISTRIBUTION SUPPORT	1	1	1	1
	Q232040000	ARANDELA A6	WASHER A6	4	4	4	4
	Q262040000	ARANDELA GROW. A6 A.304	WASHER GROW. A6 A.304	4	4	4	4
	Q162040000	TUERCA EXAGONAL M6	HEXAGONAL NUT M6	4	4	4	4
26	Q307052000	JUNTA TOR.50.17X60.83X5.3	O-RING 50.17X60.83X5.3	1	1	1	1
27	Z201903000	SOPORTE RAMAS ACLARADO	RINSE BRANCH SUPPORT	2	2	2	2
	Q042021000	TORN. AVELLANADO M4X10 A.304	COUNTERSUNK SCREW M4X10	4	4	4	4
28	Z208713000	RAMA DE ACLARADO DERECHA	RIGHT RINSE BRANCH	2	2	2	2
29	Z201905000	TOBERA ACLARADO	RINSE NOZZLE	12	12	12	12
	Q307036000	JUNTA TORICA 5.28X8.84X1.78	O-RING 5.28X8.84X1.78	12	12	12	12
30	Z201906000	ENGANCHE TOBERA ACLARADO	RINSE NOZZLE HOOK	12	12	12	12
31	Z230902000	PASAMUROS DETERGENTE	DETERGENT WALL BUSHING	-	1	1	1
31	Z208927000	PASAMUROS DETERGENTE INOX	DETERGENT WALL BUSHING	-	1	1	1
	Q306024000	JUNTA Ø18X12.5X1.5	SEAL Ø18X12.5X1.5	-	1	1	1
	Q162070000	TUERCA EXAGONAL M12	HEXAGONAL NUT M12	-	1	1	1
32	Z208434000	SOPORTE DOSIFICADOR W	FEEDER SUPPORT W	-	1	1	1
	Q411304000	REMACHE AVIBULB Ø4,8	AVIBULB Ø4,8 RIVET	-	2	2	2
	Q012031000	TORNIL. EXAGONAL M5X10 A.304	HEXAGONAL BOLT M5X10 A.304	-	2	2	2
	Q232030000	ARANDELA A5	WASHER A5	-	2	2	2
	Q162030000	TUERCA EXAGONAL M5	HEXAGONAL NUT M5	-	2	2	2
33	Z208915000	DOSIFIC. DGTE. ABRILLANTA. G650	DOSE DETERGENT POLISHING C	-	1	-	-
33	Z208903000	DOSIFIC. DGTE REGULABLE G300	DOSE REGULAR DETERGENT G3	-	1	1	1
34	Z448614000	CONDUCTO ASPIRACIÓN	DUCT INTAKE	-	1	1	1
S/Nº	Z448616000	PEGATINA TOMA DETERGENTE	STICKER MAKING DETERGENT	-	1	1	1



Зип Общепит

vsezip.ru

+7(812)987-08-81

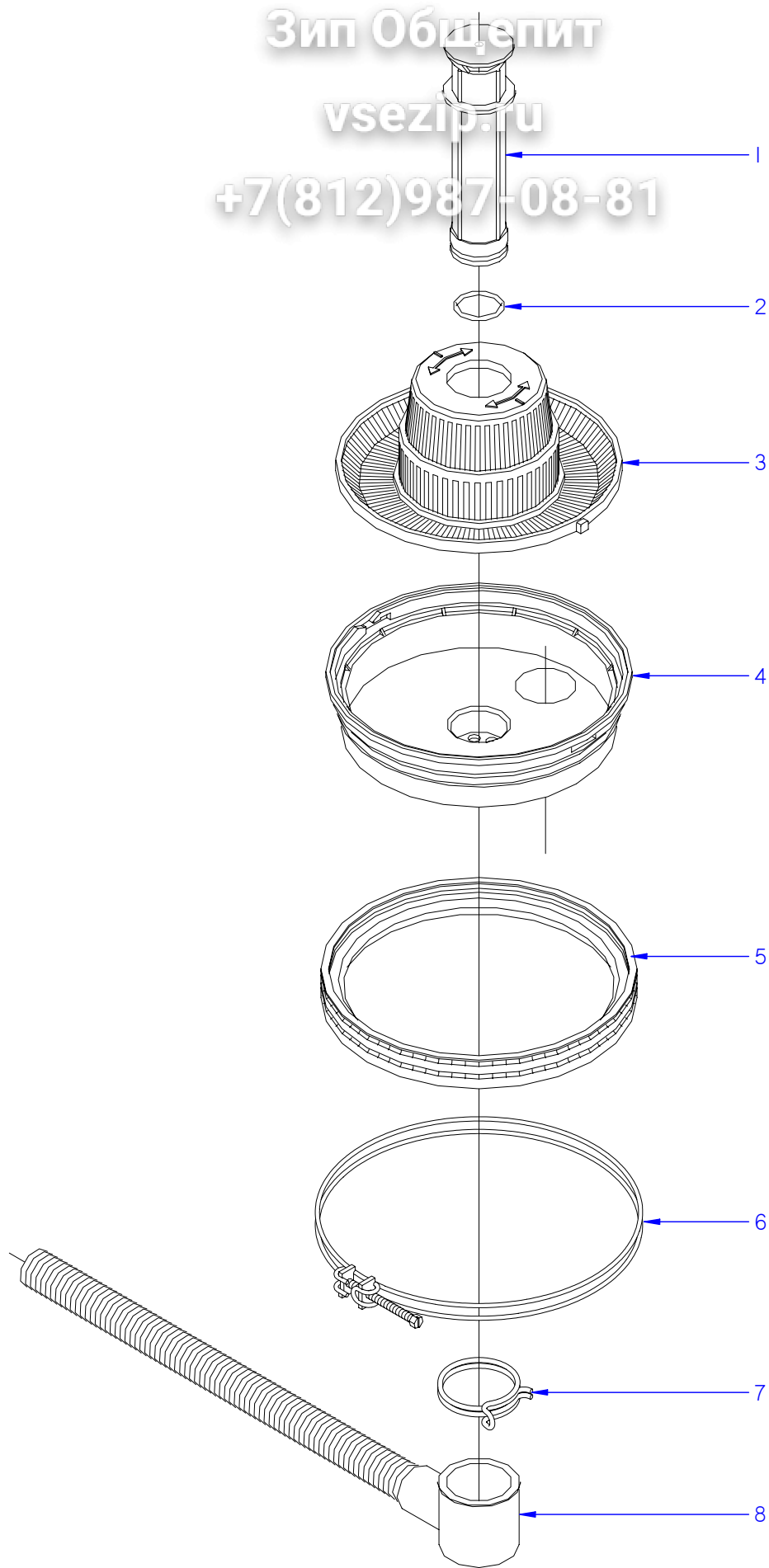

ITEM MARCADO EN COLOR = REPUESTO RECOMENDADO  
COLOURED ITEM = RECOMMENDED SPARE PART

N plano	Firma	Fecha	Aparato	CONJUNTO FUNCIONAL DESAGÜE	Lamina	<b>asber</b> 
C-2613	<i>(Signature)</i>	2009-09	LAVAVAJILLAS	LABP-300	4	

MOD.		LAVAVAJILLAS DE APERTURA FRONTAL		ZONA	CONJUNTO FUNCIONAL DESAGÜE				
ITEM	CODIGO	DENOMINACION	TEXTO	LABP-300	LABP-300 DD	LABP-300 DD UK			
1	Z200909000	ALIVIADERO	OVERFLOW	1	1	1			
2	Q307051000	JUNTA TOR.36.17X41.41X2.6	O-RING 36.17X41.41X2.6	1	1	1			
3	Z200922000	CONJUNTO FILTRO AF.	AF FILTER UNIT.	1	1	1			
4	Z200906000	CUBETA	TRAY	1	1	1			
5	Z200907000	JUNTA CUBETA	TRAY SEAL	1	1	1			
6	Z200908000	ABRAZADERA CUBETA COMPL.	COMPL. TRAY CLAMP	1	1	1			
7	Q901308000	ABRAZAD. ELAST. 56-58.8	ELAST. CLAMP 56-58.8	1	1	1			
8	Z200910000	MANGUERA DESAGUE	DRAINAGE HOSE	1	1	1			

Зип Общепит

vsezip.ru

+7(812)987-08-81

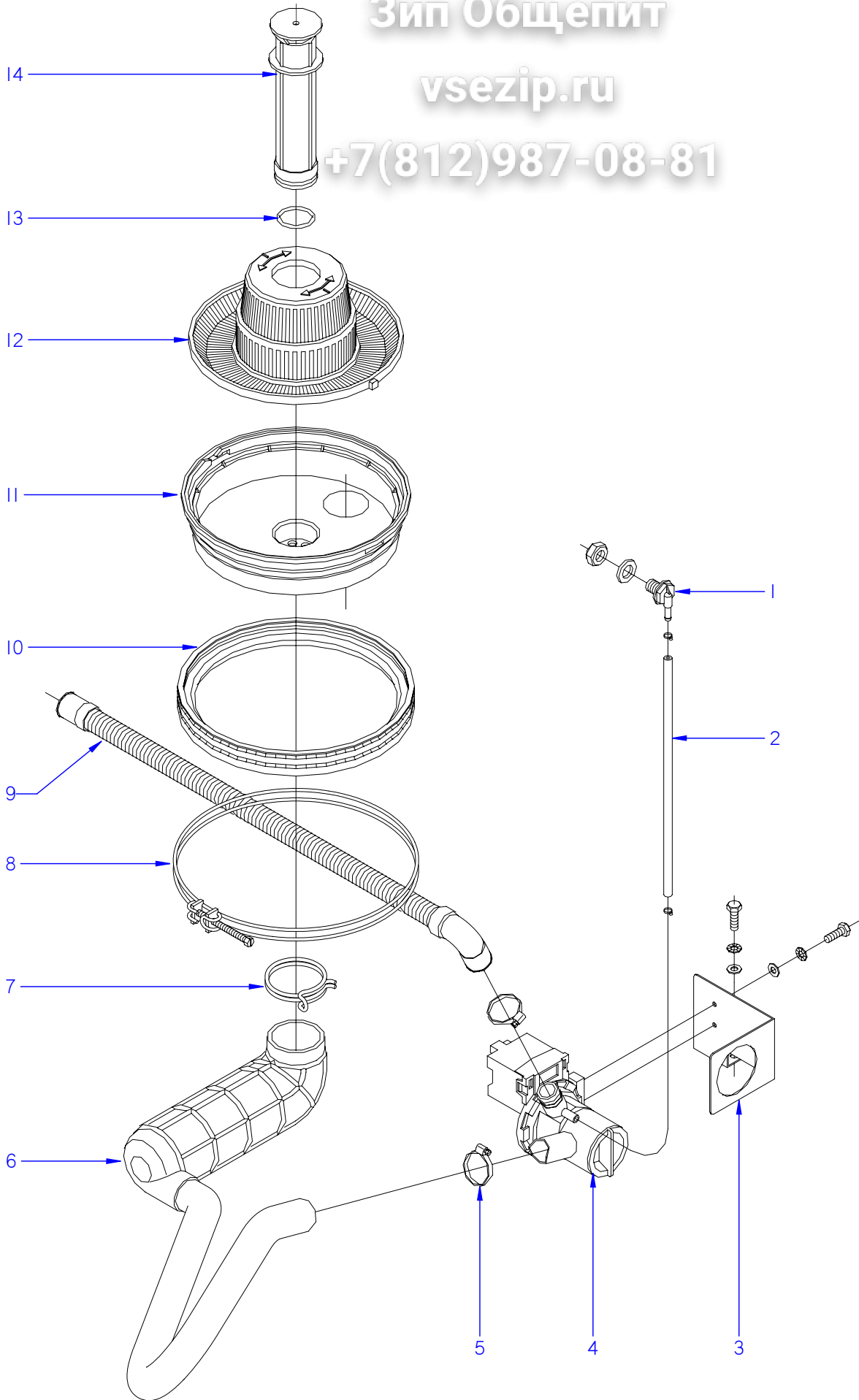

ITEM MARCADO EN COLOR = REPUESTO RECOMENDADO  
COLOURED ITEM = RECOMMENDED SPARE PART

N plano	Firma	Fecha	Aparato	CONJUNTO FUNCIONAL DESAGÜE	Lamina	
C-2613a	<i>[Signature]</i>	2009-09	LAVAVAJILLAS	LABP-300B-BT	5	asber 

**MOD.**
**LAVAVAJILLAS DE APERTURA FRONTAL**
**ZONA**
**CONJUNTO FUNCIONAL DESAGÜE**
vsezip.ru
+7(812)987-08-81

ITEM	CODIGO	DENOMINACION	TEXTO	LABP-300B BT				
1	Z230902000	PASAMUROS DETERGENTE	DETERGENT WALL BUSHING	1				
	Q306024000	JUNTA Ø18X12.5X1.5	SEAL Ø18X12.5X1.5	1				
	Q162070000	TUERCA EXAGONAL M12	HEXAGONAL NUT M12	1				
2	3702400000	TUBO GOMA NEGRO Ø 8*4	BLACK RUBBER PIPE Ø 8*4	1				
	P102154000	BRIDA ELASTICA TUBO	ELASTIC PIPE FLANGE	2				
3	Z220904000	SOPORTE BOMBA DESAGUE	DRAINAGE PUMP SUPPORT	1				
	Q012031000	TORNIL.EXAGONAL M5X10 A.304	HEX BOLT M5X10 A.304	4				
	Q242030000	ARAND.ABAN. A5 A.304	FAN WASHER A5 A.304	4				
	Q232030000	ARANDELA A5	WASHER A5	4				
4	Z220901000	BOMBA DESAGUE 30W	DRAINAGE PUMP 30W	1				
5	Q881305000	ABRAZADERA 25-40	CLAMP 25-40	2				
6	Z220902000	ACUMULADOR 1503019	ACCUMULATOR 1503019	1				
7	Q901308000	ABRAZAD. ELAST. 56-58.8	ELAST. CLAMP 56-58.8	1				
8	Z200908000	ABRAZADERA CUBETA COMPL.	COMPL. TRAY CLAMP	1				
9	Z220903000	MANGUERA DESAGUE	DRAINAGE HOSE	1				
10	Z200907000	JUNTA CUBETA	TRAY SEAL	1				
11	Z200906000	CUBETA	TRAY	1				
12	Z200922000	CONJUNTO FILTRO AF.	AF FILTER UNIT.	1				
13	Q307051000	JUNTA TOR.36.17X41.41X2.6	O-RING 36.17X41.41X2.6	1				
14	Z200909000	ALIVIADERO	OVERFLOW	1				

Зип Общепит

vsezip.ru

+7(812)987-08-81

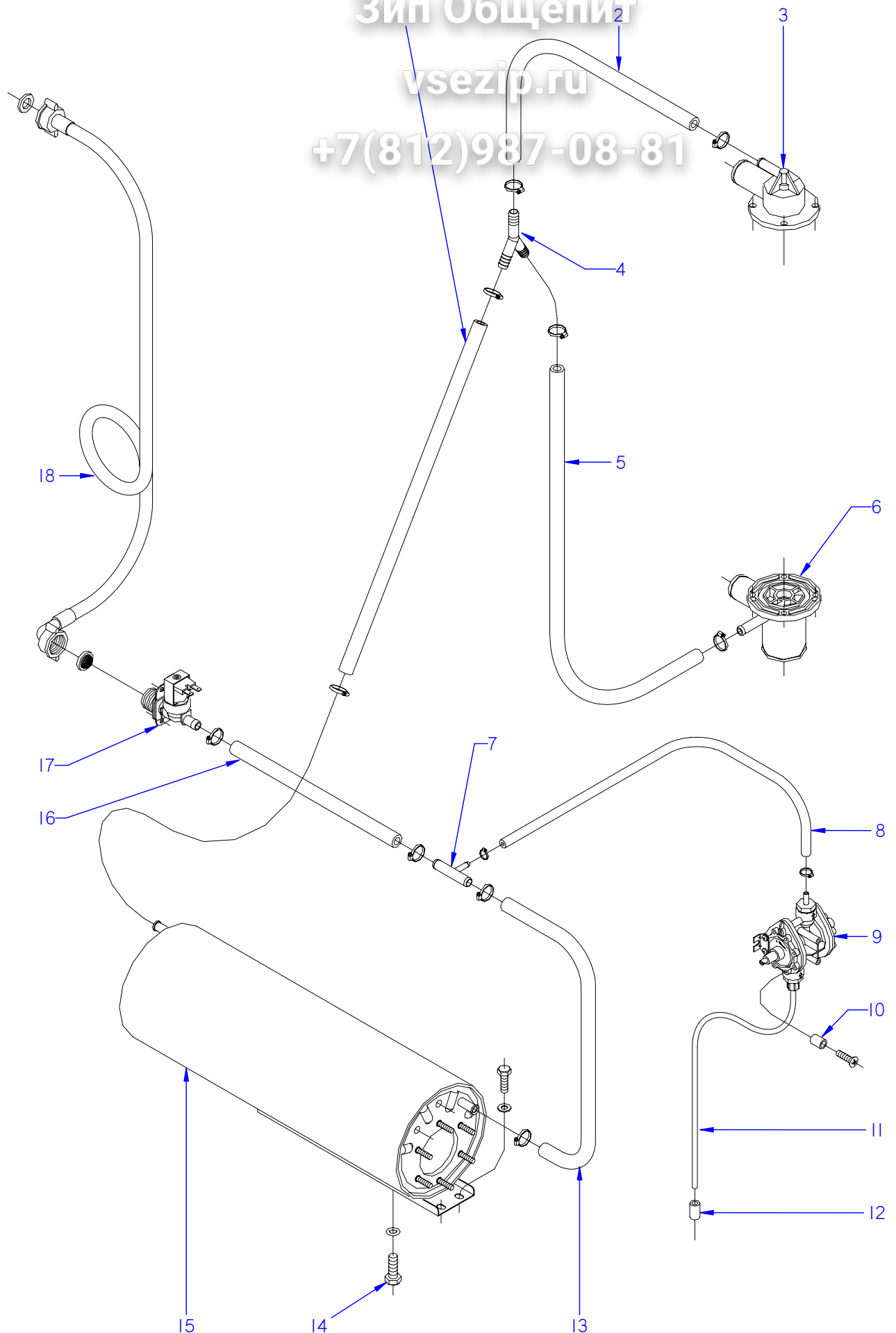

ITEM MARCADO EN COLOR = REPUESTO RECOMENDADO  
COLOURED ITEM = RECOMMENDED SPARE PART

N plano	Firma	Fecha	Aparato	CONJUNTO FUNCIONAL ACLARADO	Lamina	
C-2614	<i>name Benfor</i>	2009-09	LAVAVAJIL. LABP-300 / DD / DD UK		6	asber 



**MOD.**
**LAVAVAJILLAS DE APERTURA FRONTAL**
**ZONA**
**vsezip.ru**
**CONJUNTO FUNCIONAL ACLARADO**

ITEM	CODIGO	DENOMINACION	TEXTO	LABP-300	LABP-300 DD	LABP-300 DD UK		
1	3676900000	TUBO GOMA NEGRA Ø 17*10	BLACK RUBBER PIPE 17*10	1	1	1		
	Q881302000	ABRAZADERA 12-20	CLAMP 12-20	2	2	2		
2	3676900000	TUBO GOMA NEGRA Ø 17*10	BLACK RUBBER PIPE 17*10	1	1	1		
	Q881302000	ABRAZADERA 12-20	CLAMP 12-20	2	2	2		
3	Z200707000	SOPORTE DISTRIB. SUPERIOR	UPPER DISTRIB. SUPPORT	1	1	1		
4	Z201106000	RACORD EN Y	Y-CONNECTION	1	1	1		
5	3676900000	TUBO GOMA NEGRA Ø 17*10	BLACK RUBBER PIPE 17*10	1	1	1		
	Q881302000	ABRAZADERA 12-20	CLAMP 12-20	2	2	2		
6	Z200703000	PASAMUROS	BUSHING	1	1	1		
7	Z601157000	TOMA PRESION	PRESSURE INTAKE	1	1	1		
8	3704000000	TUBO GOMA NEGRO D 10,5*5	BLACK RUBBER PIPE Ø 10.5*5	1	1	1		
	Q881308000	ABRAZADERA 8-14L	CLAMP 8-14L	2	2	2		
9	Z211109000	DOSIFICADOR TENSOACTIVO N-6	SURFACE ACTIVE DISPENSER	1	1	1		
10	Z203007000	CASQUILLO	BUSHING	2	2	2		
	Q041324000	TORN. AVELLA. M4x25 H.ZINCADO	COUNTERSUNK NUT M4x25 H.ZI	2	2	2		
11	Z448618000	CONDUCTO ABRILL AZUL COMPL	CROCKERY POLISHER PIPE	1	1	1		
12	Z701152000	PESO FILTRO	FILTER WEIGHT	1	1	1		
13	3676900000	TUBO GOMA NEGRA Ø 17*10	BLACK RUBBER PIPE 17*10	1	1	1		
	Q881302000	ABRAZADERA 12-20	CLAMP 12-20	2	2	2		
14	Q012063000	TORNIL. EXAGONAL M10x20 A.304	HEXAGONAL BOLT M10X20 A.304	1	1	1		
	Q307048000	JUNTA TORICA Ø9.12X16.18X3.53	O-RING Ø9.12X16.18X3.53	1	1	1		
15	Z201710000	CALDERIN COMPLETO	COMPLETE DRUM	1	1	1		
	Q012031000	TORNIL. EXAGONAL M5x10 A.304	HEXAGONAL BOLT M5x10 A.304	2	2	2		
	Q232030000	ARANDELA A5	WASHER A5	2	2	2		
16	3676900000	TUBO GOMA NEGRA Ø 17*10	BLACK RUBBER PIPE 17*10	1	1	1		
	Q881302000	ABRAZADERA 12-20	CLAMP 12-20	2	2	2		
17	Z701135000	ELECTR. SIMP.220V COD.255.208	SOLENOID VALVE SIMP.220V CO	1	1	1		
	Q152024000	TORN. AVELLANADO M4x8 A.304	HEXAGONAL COUNTERSUNK M4	2	2	2		
18	Z602121000	MANGUERA ENTRADA AGUA	WATER INTAKE HOSE	1	1	1		

Зип Общепит

vsezip.ru

+7(812)987-08-81

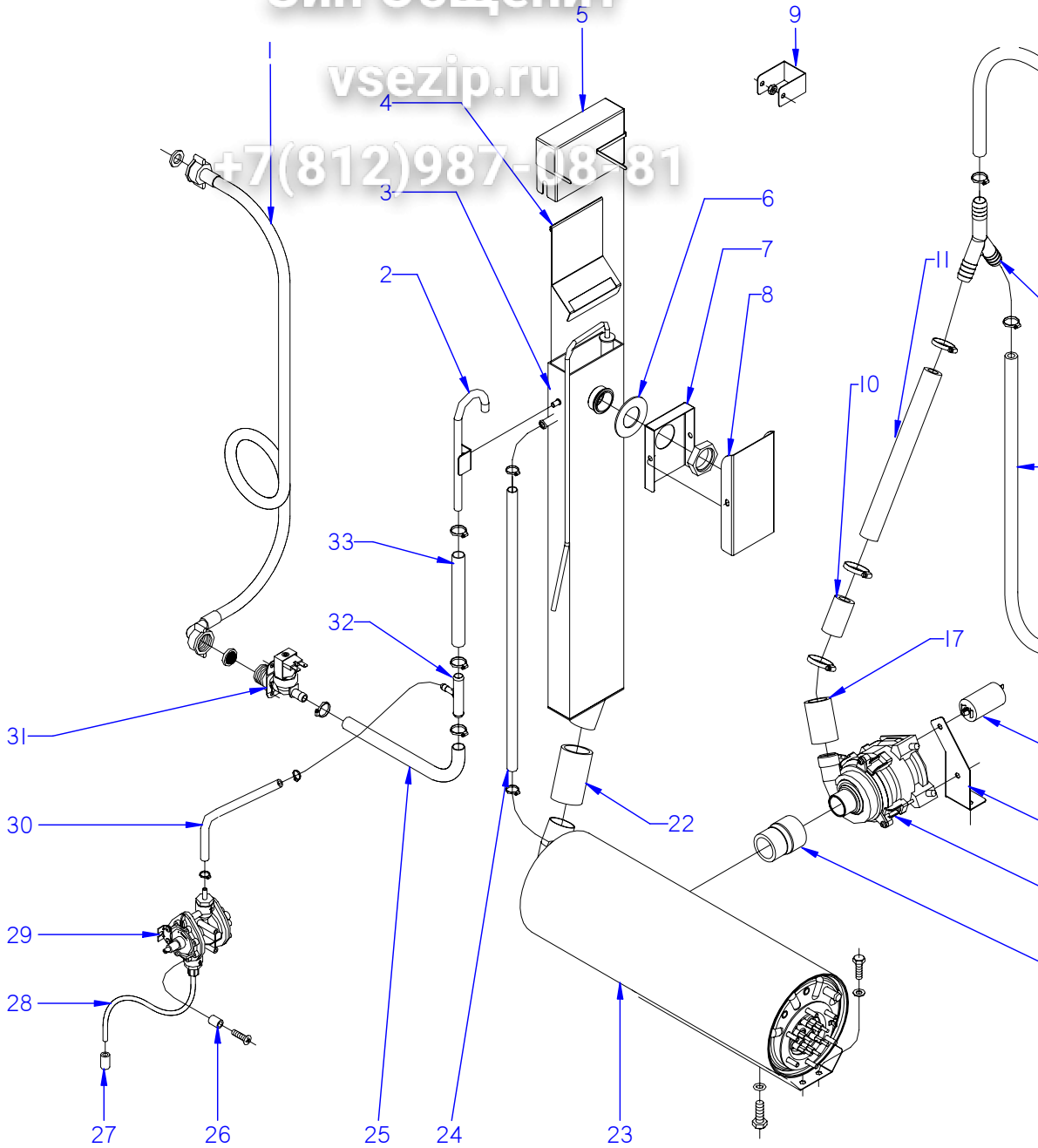

ITEM MARCADO EN COLOR = REPUESTO RECOMENDADO  
COLOURED ITEM = RECOMMENDED SPARE PART

N plano	C-2614a
Firma	<i>(Signature)</i>
Fecha	2009-09
Aparato	LAVAVAJILLAS LAVP-300B-BT
CONJUNTO FUNCIONAL ACABADO	
Lamina	7

MOD. LAVAVAJILLAS DE APERTURA FRONTAL

ZONA

CONJUNTO FUNCIONAL ACLARADO

vsezip.ru

+7(812)987-08-81

ITEM	CODIGO	DENOMINACION	TEXTO	LABP-300B BT				
1	Z602121000	MANGUERA ENTRADA AGUA	WATER INTAKE HOSE	1				
2	Z258903000	CANO COMPLETO	COMPLETE SPOUT	1				
	Q232040000	ARANDELA A6	WASHER A6	1				
	Q162040000	TUERCA EXAGONAL M6	HEXAGONAL NUT M6	1				
3	Z258906000	DEPÓSITO COMPLETO	COMPLETE TANK	1				
4	Z258953000	TAPA INTERIOR DEPOSITO	TANK INNER COVER	1				
5	Z258955000	CUBIERTA DEPÓSITO	TANK COVER	1				
	Q162040000	TUERCA EXAGONAL M6	HEXAGONAL NUT M6	1				
	Q232040000	ARANDELA A6	WASHER A6	1				
6	R675007000	JUNTA RETENCION VAPORES	STEAM RETAINER SEAL	1				
7	Z258938000	CUBIERTA PASAMUROS INTER.	INTER. BUSHING COVER	1				
	Q223014000	CONTRATUERCA 1 LATON	COUNTERNUT 1 BRASS	1				
8	Z258939000	CUBIERTA PASAMUROS EXTER.	EXTER. BUSHING COVER	1				
9	R722631000	FIJACION ALERON	AILERON FASTENING	1				
	Q162040000	TUERCA EXAGONAL M6	HEXAGONAL NUT M6	1				
10	Z257403000	MANGUITO IMPULSIÓN	IMPULSE HOSE	1				
11	3722600000	TUBO EPDM 28.5 X 22 REFORZ.	PIPE EPDM 28.5 X 22 REINF.	1				
12	3715300000	TUBO GOMA NEGRA Ø 14*24	BLACK RUBBER PIPE 14*24	1				
	Q881360000	ABRAZADERA 16-27	CLAMP 16-27	2				
13	Z200707000	SOPORTE DISTRIB. SUPERIOR	UPPER DISTRIB. SUPPORT	1				
14	Z201106000	RACORD EN Y	Y-CONNECTION	1				
15	3715300000	TUBO GOMA NEGRA Ø 14*24	BLACK RUBBER PIPE 14*24	1				
	Q881360000	ABRAZADERA 16-27	CLAMP 16-27	2				
16	Z200703000	PASAMUROS	BUSHING	1				
17	Z258933000	MANGUITO IMPULSIÓN	IMPULSE HOSE	1				
	Q881306000	ABRAZADERA 32-50 L	CLAMP 32-50 L	4				
18	Z258927000	CONDENSADOR 3 µF	CONDENSER 3 µF	1				

MOD. LAVAVAJILLAS DE APERTURA FRONTAL

ZONA

CONJUNTO FUNCIONAL ACLARADO

vsezip.ru

+7(812)987-08-81

ITEM	CODIGO	DENOMINACION	TEXTO	LABP-300B BT				
19	Z258929000	SOPORTE M. BOMBA ACLARADO	M-PUMP SUPPORT RINSE	1				
	Q221342000	REMACHE EXAGONAL M5	HEXAGONAL RIVET M5	4				
	Q032035000	TORNILLO ALOMADO M5x30	CURVED SCREW M5X30	2				
	Q232030000	ARANDELA A5	WASHER A5	2				
	Q012031000	TORNILLO EXAGONAL M5x10	HEXAGONAL BOLT M5x10	2				
20	Z258926000	MOTOBOMBA	MOTORPUMP	1				
21	Z258931000	MANGUITO REDUCCIÓN	REDUCTION HOSE	1				
22	Z258925000	MANGUITO CONEXIÓN	CONNECTION HOSE	1				
	Q881306000	ABRAZADERA 32-50 L	CLAMP 32-50 L	2				
23	Z258916000	CALDERIN COMPLETO BBT	COMPLETE DRUM BBT	1				
	Q012031000	TORNIL. EXAGONAL M5x10 A.304	HEXAGONAL BOLT M5x10 A.304	2				
	Q232030000	ARANDELA A5	WASHER A5	2				
24	3676900000	TUBO GOMA NEGRA Ø 17*10	BLACK RUBBER PIPE 17*10	1				
	Q881302000	ABRAZADERA 12-20	CLAMP 12-20	2				
25	3676900000	TUBO GOMA NEGRA Ø 17*10	BLACK RUBBER PIPE 17*10	1				
	Q881302000	ABRAZADERA 12-20	CLAMP 12-20	2				
26	Z203007000	CASQUILLO	BUSHING	2				
	Q041324000	TORN. AVELLA. M4x25 H.ZINCADO	COUNTERSUNK NUT M4x25 H.ZI	2				
27	Z701152000	PESO FILTRO	FILTER WEIGHT	1				
28	Z448618000	CONDUCTO ABRILLANTADOR	POLISH DUCT	1				
29	Z651123000	DOSIFICADOR TENSOACTIVO	SURFACE ACTIVE DISPENSER	1				
30	3704000000	TUBO GOMA NEGRO D 10,5*5	BLACK RUBBER PIPE Ø 10.5*5	1				
	Q881308000	ABRAZADERA 8-14L	CLAMP 8-14L	2				
31	Z701135000	ELECTR. SIMP.220V COD.255.208	SOLENOID VALVE SIMP.220V CO	1				
	Q152024000	TORN. AVELLANADO M4x8 A.304	COUNTERSUNK NUT M4x8 A.304	2				
32	Z718949000	TE TOMA PRESION	PRESSURE INTAKE T	1				
33	3676900000	TUBO GOMA NEGRA Ø 17*10	BLACK RUBBER PIPE 17*10	1				
	Q881302000	ABRAZADERA 12-20	CLAMP 12-20	2				

Зип Общепит

vsezip.ru

+7(812)982-08-81

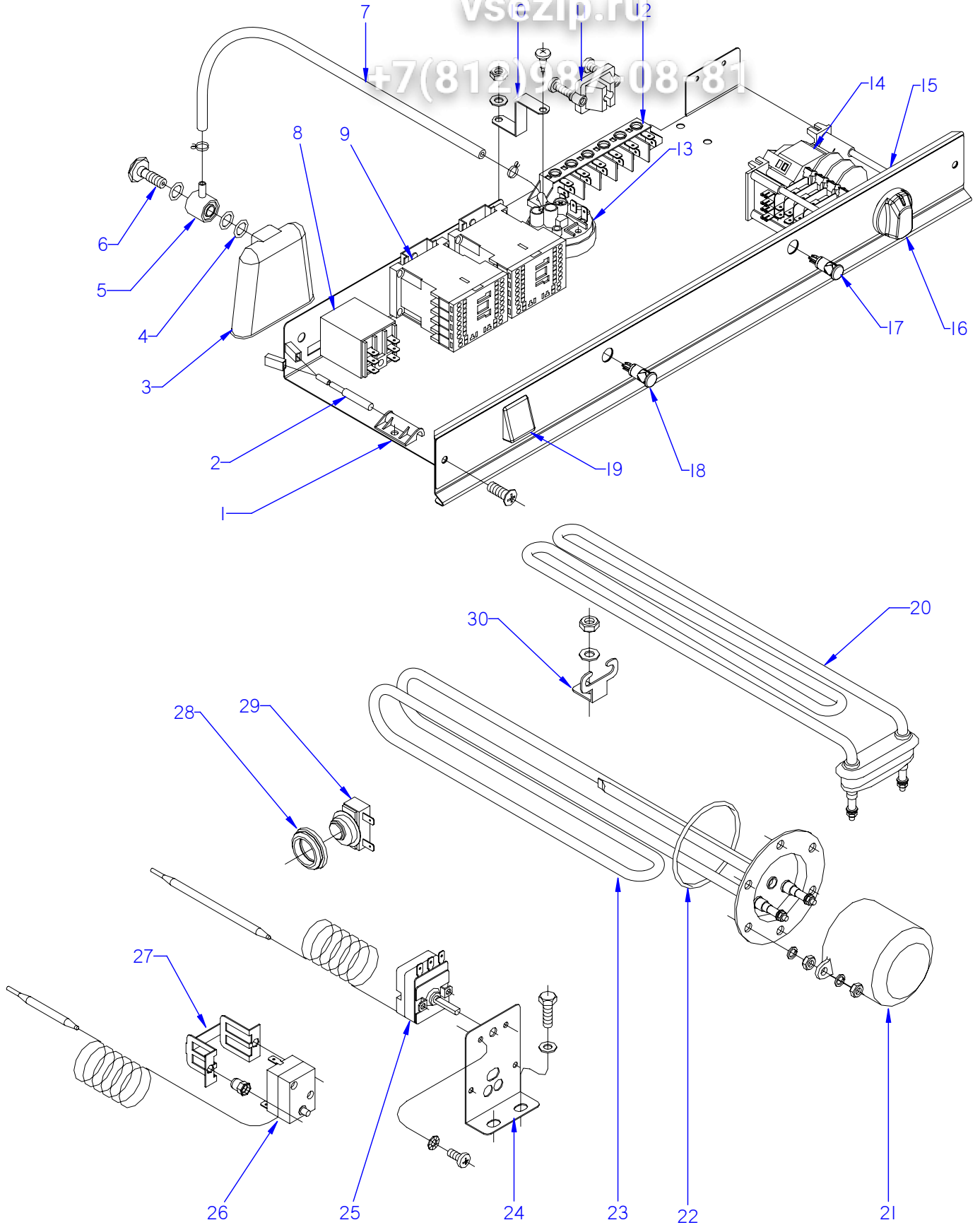

ITEM MARCADO EN COLOR = REPUESTO RECOMENDADO  
COLOURED ITEM = RECOMMENDED SPARE PART

N plano	Firma	Fecha	Aparato	CONJUNTO FUNCIONAL ELECTRICO	Lamina	
C-2615	<i>[Signature]</i>	2009-09	LAVAVAJIL. LABP-300 / DD / DD UK	8		

MOD.	LAVAVAJILLAS DE APERTURA FRONTAL	ZONA	CONJUNTO FUNCIONAL ELECTRICO
------	----------------------------------	------	------------------------------

ITEM	CODIGO	DENOMINACION	TEXTO	LABP-300	LABP-300 DD	LABP-300 DD UK		
1	Z203010000	AMARRE INTERRUPT. MAGNETICO	MAGNETIC SWITCH FASTENER	1	1	1		
	Q152004000	TORNIL, APLASTADO M5x13 A304	FLAT HEADED BOLT M5x13 A304	1	1	1		
	Q232030000	ARANDELA A5	WASHER A5	1	1	1		
	Q162030000	TUERCA EXAGONAL M5	HEXAGONAL NUT M5	1	1	1		
2	Z203009000	INTERRUPTOR MAGNETICO	MAGNETIC SWITCH	1	1	1		
3	Z203011000	CAMARA PRESOSTATO	PRESSURE SWITCH	1	1	1		
4	Q307003000	JUNTA TORICA 16.01X10.77X2.62	O-RING 16.01X10.77X2.62	3	3	3		
5	Z203012000	EMPALME PRESOSTATO	PRESSURE SWITCH CONNEX	1	1	1		
6	Z203013000	TORNILLO PRESOSTATO	PRESSURE SWITCH BOLT	1	1	1		
7	3702400000	TUBO GOMA NEGRO Ø 8*4	BLACK RUBBER PIPE Ø 8*4	1	1	1		
	P102154000	BRIDA ELASTICA TUBO	ELASTIC PIPE FLANGE	2	2	2		
8	Z203062000	RELE 230V. 16A 50-60 HZ	RELAY 230V. 16A 50-60 HZ	1	1	1		
9	Z203050000	CONTAC. SIRIUS 3R 230V.50-60	CONTACTOR SIRIUS 3R 230V50-	2	2	2		
	Z123018000	GUIA CONTACTOR L-55	CONTACTOR GUIDE L-55	2	2	2		
	Q419005000	REMACHE 4X8 ALMG 3 / ALUMINIO	RIVET 4X8 ALMG 3 / ALUMINIO	4	4	4		
10	Z602923000	SOPORTE PRESOSTATO	PRESSURE SWITCH SUPPORT	1	1	1		
	Q082032000	TORNILLO ALOMADO BZ-3,5X9,5	CURVED SCREW BZ-3.5x9.5	1	1	1		
	Q152004000	TORNILLO APLASTADO M5x13	FLAT HEAD SCREW M5X13	1	1	1		
	Q232030000	ARANDELA A5	WASHER A5	1	1	1		
	Q162030000	TUERCA EXAGONAL M5	HEXAGONAL NUT M5	1	1	1		
11	Z203020000	RETENEDOR DE CABLE	CABLE HOLDER	1	1	1		
12	R253044000	REGLETA AUXILIAR FV-122	AUXILIARY TERMINAL STRIP FV-	1	1	1		
	Q152004000	TORNILLO APLASTADO M5x13	FLAT HEAD SCREW M5X13	2	2	2		
	Q232030000	ARANDELA A5	WASHER A5	2	2	2		
	Q162030000	TUERCA EXAGONAL M5	HEXAGONAL NUT M5	2	2	2		
13	Z203023000	PRESOSTATO SIMPLE PVS	SIMPLE PVS PRESSURE SWITCH	1	1	1		
14	Z203030000	PROGRAMADOR CICLO	CYCLE PROGRAMMER	1	1	1		
	Z203007000	CASQUILLO	BUSHING	2	2	2		
	Q041324000	TORN. AVELLA. M4x25 H.ZINCADO	COUNTERSUNK NUT M4x25 H.ZI	2	2	2		

+7(812)987-08-81

ITEM	CODIGO	DENOMINACION	TEXTO	LABP-300	LABP-300 DD	LABP-300 DD UK		
15	Z208734000	FRENTE EXTRAIBLE ASPES	COMPLETE FRONT	1	1	1		
S/Nº	Z208765000	EMBELLECE. ADHESIVO LABP-300	ADHESIVE TRIM LABP-300	1	1	1		
S/Nº	Z208768000	EMBELLECE. ADHESIVO LABP-300	ADHESIVE TRIM LABP-300	1	1	1		
	Q152004000	TORNILLO APLASTADO M5x13	FLAT HEADED BOLT M5x13 A304	2	2	2		
16	Z214902000	BOTON DE MANDO	CONTROL BUTTON	1	1	1		
17	R693056000	PILOTO AMBAR 41227000A4	AMBER PILOT 41227000A4	1	1	1		
18	R693055000	PILOTO VERDE 41227000C7	GREEN PILOT 41227000C7	1	1	1		
19	Z203033000	INTERRUPTOR GENERAL	GENERAL SWITCH	1	1	1		
20	Z203601000	RESISTENCIA TANQUE	TANK RESISTOR	1	1	—		
20	R223005000	RESISTENCIA TANQUE	TANK RESISTOR	—	—	1		
21	Z651731000	CAPERUZA RESISTEN. CALDERIN	DRUM RESIST. CAP	1	1	1		
21	Z101723000	CAPERUZA RESISTEN. CALDERIN	DRUM RESIST. CAP	1	1	1		
	Q163140000	TUERCA EXAGONAL M6 LATON	HEXAGONAL NUT M6 BRASS	2	2	2		
22	Q307035000	JUNTA TORICA AN-36 282333	O-RING AN-36 282333	1	1	1		
23	Z201706000	RESISTENCIA CALDERIN	DRUM RESISTOR	1	1	—		
23	Z201708000	RESISTENC. CALDERIN AF 2200W	AF 2200W DRUM RESISTOR	—	—	1		
	Q221305000	TUERCA EX.AUTO M4 ZINCADA	HEXAGONAL NUT M4	2	2	2		
	Q163140000	TUERCA EXAGONAL M6 LATON	HEXAGONAL NUT M6	6	6	6		
	Q262040000	ARANDELA GROW. A6 A.304	WASHER GROW. A6 A.304	6	6	6		
24	Z203047000	SOPORTE TERMOSTATOS	THERMOSTAT SUPPORT	1	1	1		
	Q012031000	TORNIL. EXAGONAL M5X10 A.304	HEXAGONAL BOLT M5X10 A.304	2	2	2		
	Q232030000	ARANDELA A5	WASHER A5	2	2	2		
	Q152024000	TORNIL. AVELLANADO M4X8 A304	COUNTERSUNK BOLT M4X8 A304	2	2	2		
25	Z203014000	TERMOSTATO CALDERIN	WASH DRUM THERMOSTAT	1	1	1		
26	Z213014000	LIMITADOR TECASA P.	LIMITER TECASA P.	1	1	1		
27	Z203060000	AMARRE LIMITADOR TECASA	LIMITER FASTENING TECASA	1	1	1		
	Q221341000	REMACHE EXAGONAL M4	HEXAGONAL RIVET M4	2	2	2		
	Q152024000	TORNIL. AVELLANADO M4X8 A304	COUNTERSUNK BOLT M4X8 A304	2	2	2		
28	N503017000	SOPORTE TERMOSTATO 1001713	THERMOSTAT SUPPORT 1001713	1	1	1		
29	Z718405000	TERMOSTATO DOBLE	DOUBLE THERMOSTAT	1	1	1		

MOD. **LAVAVAJILLAS DE APERTURA FRONTAL** ZONA **CONJUNTO FUNCIONAL ELECTRICO**

vsezip.ru

+7(812)987-08-81

ITEM	CODIGO	DENOMINACION	TEXTO	LABP-300	LABP-300 DD	LABP-300 DD UK		
30	Z603602000	SOPORTE RESISTENCIA TANQUE	TANK RESISTOR SUPPORT	1	1	1		
	Q232040000	ARANDELA A6	WASHER A6	1	1	1		
	Q162040000	TUERCA EXAGONAL M6	HEXAGONAL NUT M6	1	1	1		



Зип Общежит

vsezip.ru

+7(812)987-09991

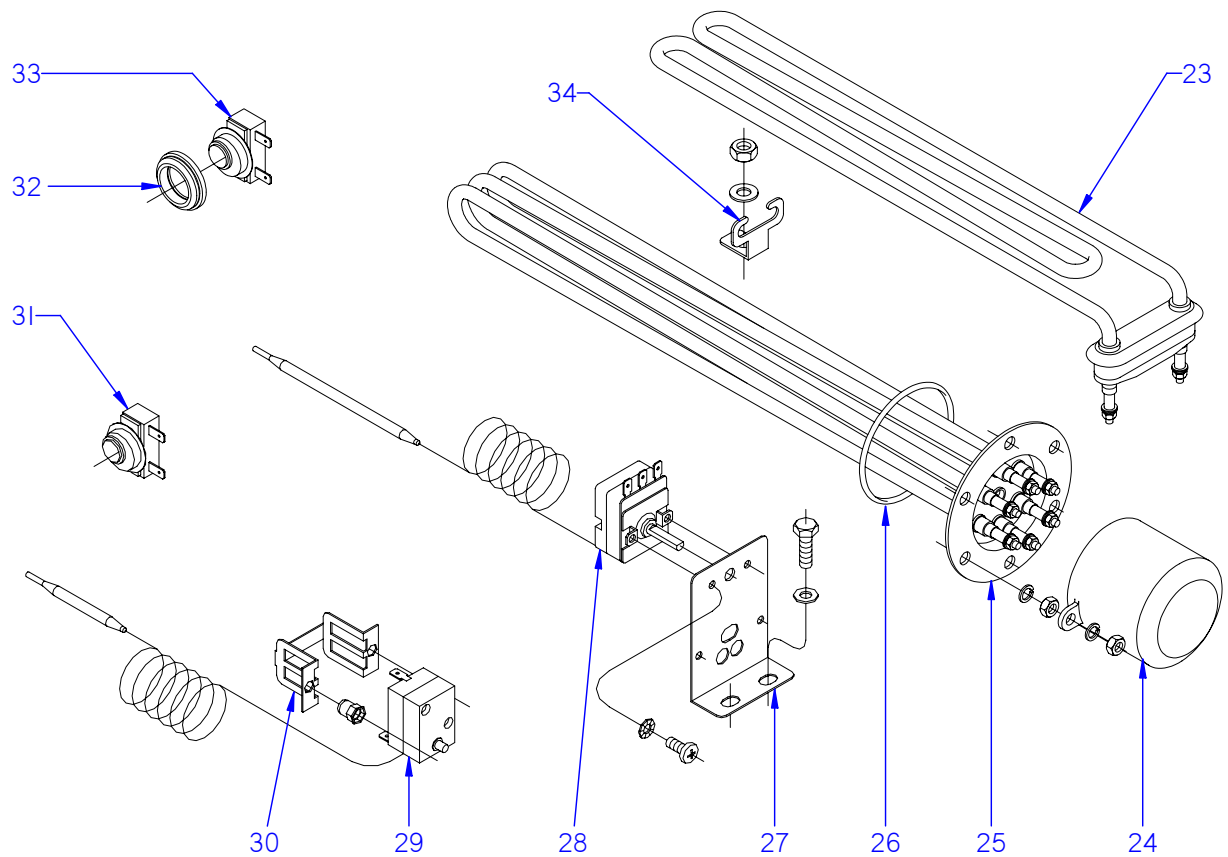
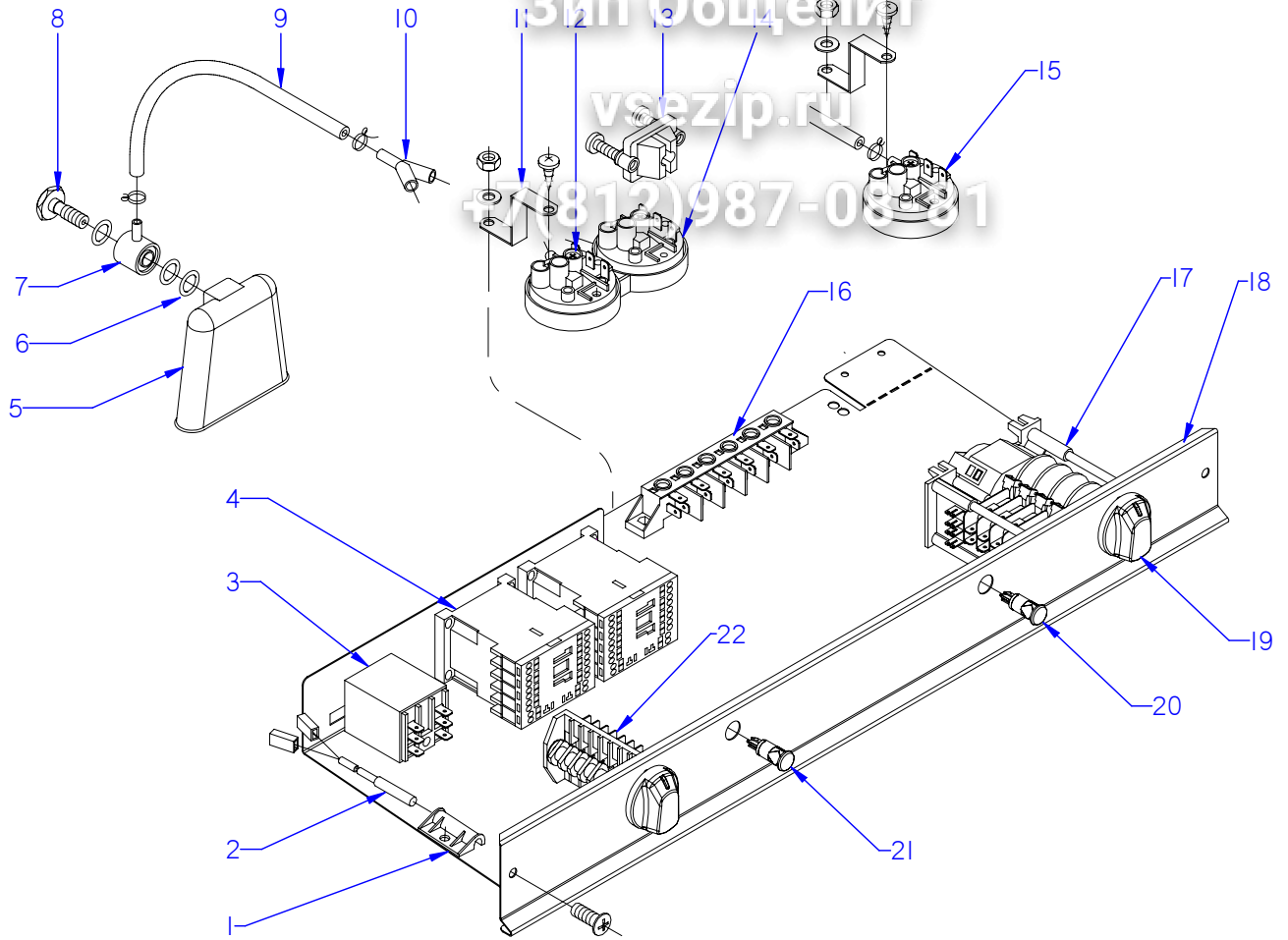

ITEM MARCADO EN COLOR = REPUESTO RECOMENDADO  
COLOURED ITEM = RECOMMENDED SPARE PART

N plano	Firma	Fecha	Aparato	CONJUNTO FUNCIONAL ELECTRICO	Lamina	
C-2615a	[Signature]	2009-09	LAVAVAJILLAS LABP-300B-BT		9	asber 

MOD. LAVAVAJILLAS DE APERTURA FRONTAL

ZONA

CONJUNTO FUNCIONAL ELECTRICO

vsezip.ru

+7(812)987-08-81

ITEM	CODIGO	DENOMINACION	TEXTO	LABP-300B BT				
1	Z203010000	AMARRE INTERRUPTOR MAGNETICO	MAGNETIC SWITCH FASTENER	1				
	Q152004000	TORNILLO APLASTADO M5x13 A304	FLAT HEADED BOLT M5x13 A304	1				
	Q232030000	ARANDELA A5	WASHER A5	1				
	Q162030000	TUERCA EXAGONAL M5	HEXAGONAL NUT M5	1				
2	Z203009000	INTERRUPTOR MAGNETICO	MAGNETIC SWITCH	1				
3	Z203062000	RELE 230V. 16A 50-60 HZ	RELAY 230V. 16A 50-60 HZ	1				
4	Z203050000	CONTACTOR SIRIUS 3R 230V.50-60	CONTACTOR SIRIUS 3R 230V50-	2				
	Z123018000	GUIA CONTACTOR L-55	CONTACTOR GUIDE L-55	1				
	Q419005000	REMACHE 4X8 ALMG 3 / ALUMINIO	RIVET 4X8 ALMG 3 / ALUMINIO	2				
5	Z203011000	CAMARA PRESOSTATO	PRESSURE SWITCH	1				
6	Q307003000	JUNTA TORICA 16.01X10.77X2.62	O-RING 16.01X10.77X2.62	3				
7	Z203012000	EMPALME PRESOSTATO	PRESSURE SWITCH CONNEX	1				
8	Z203013000	TORNILLO PRESOSTATO	PRESSURE SWITCH BOLT	1				
9	3702400000	TUBO GOMA NEGRO Ø 8*4	BLACK RUBBER PIPE Ø 8*4	1				
	P102154000	BRIDA ELASTICA TUBO	ELASTIC PIPE FLANGE	2				
10	Z103077000	RACORD EN Y	Y-CONNECTION	1				
11	Z602923000	SOPORTE PRESOSTATO	PRESSURE SWITCH SUPPORT	2				
	Q082032000	TORNILLO ALOMADO BZ-3,5X9,5	CURVED SCREW BZ-3.5x9.5	2				
	Q152004000	TORNILLO APLASTADO M5x13	FLAT HEAD SCREW M5X13	2				
	Q232030000	ARANDELA A5	WASHER A5	2				
	Q162030000	TUERCA EXAGONAL M5	HEXAGONAL NUT M5	2				
12	Z203023000	PRESOSTATO SIMPLE PVS	SIMPLE PVS PRESSURE SWITCH	1				
13	Z203020000	RETENEDOR DE CABLE	CABLE HOLDER	1				
14	Z223005000	PRESOSTATO SIMPLE P.V.S.	SIMPLE P.V.S. PRESSURE SWITC	1				
15	Z213059000	TRIPLE PRESOSTATO 40-120-150	TRIPLE PRESSURE SWITCH 40-1	1				
16	R253044000	REGLETA AUXILIAR FV-122	AUXILIARY TERMINAL STRIP FV-	1				
	Q152004000	TORNILLO APLASTADO M5x13	FLAT HEAD SCREW M5X13	2				
	Q232030000	ARANDELA A5	WASHER A5	2				
	Q162030000	TUERCA EXAGONAL M5	HEXAGONAL NUT M5	2				
17	Z203030000	PROGRAMADOR CICLO	CYCLE PROGRAMMER	1				
	Z203007000	CASQUILLO	BUSHING	2				

**MOD.**
**LAVAVAJILLAS DE APERTURA FRONTAL**
**ZONA**
**vsezip.ru**
**CONJUNTO FUNCIONAL ELECTRICO**

ITEM	CODIGO	DENOMINACION	TEXTO	LABP-300B BT				
18	Z208734000	FRENTE EXTRAIBLE ASPES	REMOVABLE FRONT ASPES	1				
	Z208767000	ADHESIVO ASPES LABP-300 B BT	TRIM ADHESIVE LABP-300 B BT	1				
	Z208769000	ADHESIVO ASPES LABP-300 B BT	TRIM ADHESIVE LABP-300 B BT	1				
19	Z214902000	BOTON DE MANDO	CONTROL BUTTON	2				
20	R693056000	PILOTO AMBAR 41227000A4	AMBER PILOT 41227000A4	1				
21	R693055000	PILOTO VERDE 41227000C7	GREEN PILOT 41227000C7	1				
22	Z223001000	CONMUTADOR DE FUNCIONES	FUNCTIONS SWITCH	1				
S/Nº	Z202920000	SOPORTE CONMUTADOR 2	THERMOSTAT SUPPORT	1				
23	R223005000	RESISTENCIA TANQUE	TANK RESISTOR	1				
24	Z651731000	CAPERUZA RESISTEN. CALDERIN	DRUM RESIST. CAP	1				
24	Z101723000	CAPERUZA RESISTEN. CALDERIN	DRUM RESIST. CAP	1				
	Q163140000	TUERCA EXAGONAL M6 LATON	HEXAGONAL NUT M6 LATON	2				
25	Z201708000	RESISTENCIA CALDERIN AF 2200W	DRUM RESISTOR AF 2200W	1				
	Q221305000	TUERCA EX.AUTO M4 ZINCADA	EX.AUTO NUT M4 ZINC-COATED	2				
	Q163140000	TUERCA EXAGONAL M6 LATON	HEXAGONAL NUT M6 BRASS	6				
	Q262040000	ARANDELA GROW. A6 A.304	WASHER GROW. A6 A.304	6				
26	Q307035000	JUNTA TORICA AN-36 282333	O-RING 9.12x16.18x3.53	1				
27	Z203047000	SOPORTE TERMOSTATOS	THERMOSTAT SUPPORT	1				
	Q012031000	TORNIL. EXAGONAL M5X10 A.304	HEXAGONAL BOLT M5X10 A.304	2				
	Q232030000	ARANDELA A5	WASHER A5	2				
	Q152024000	TORNIL. AVELLANADO M4X8 A304	COUNTERSUNK BOLT M4X8 A304	2				
28	Z203014000	TERMOSTATO CALDERIN	WASH DRUM THERMOSTAT	1				
29	Z213014000	LIMITADOR TECASA P.	LIMITER TECASA P.	1				
30	Z203060000	AMARRE LIMITADOR TECASA	LIMITER FASTENING TECASA	1				
31	Z718405000	TERMOSTATO DOBLE	DOUBLE THERMOSTAT	2				
32	N503017000	SOPORTE TERMOSTATO 1001713	THERMOSTAT SUPPORT 1001713	1				
33	Z718405000	TERMOSTATO DOBLE	DOUBLE THERMOSTAT	2				
34	Z603602000	SOPORTE RESISTENCIA TANQUE	TANK RESISTOR SUPPORT	1				
	Q232040000	ARANDELA A6	WASHER A6	1				
	Q162040000	TUERCA EXAGONAL M6	HEXAGONAL NUT M6	1				

# Зип Общество

vsezip.ru

+7(812)987-08-81

MOD.		LAVAVAJILLAS DE APERTURA FRONTAL		ZONA	VARIOS			
ITEM	CODIGO	DENOMINACION	TEXTO	LABP-300	LABP-300B BT	LABP-300 DD	LABP-300 DD UK	
	Z206131000	FOLLETO DE INSTRUCCIONES	INSTRUCTION LEAFLET	1	1	1	1	
	Z206136000	FOLLETO DE INSTRUCCIONES	INSTRUCTION LEAFLET	1	1	1	1	
	Z203077000	ESQUEMA TEORICO FI-30	THEORETICAL DIAGRAM FI-30	1	1	1	1	
	Z203082000	ESQUEMA TEORICO FI-30 B BT	THEORET. DIAGRAM FI-30 B BT	1	1	1	1	
	Z203078000	PLANO DE MONTAJE FI-30	ASSEMBLY PLAN FI-30	1	1	1	1	
	Z203083000	ESQUEMA DE MONTAJE FI-30 B BT	ASSEMBLY PLAN FI-30 B BT	1	1	1	1	
	Z243051000	LEYENDA LAVJLL APERTURA FRON	LEGEND FRONT LOADING DISH.	1	1	1	1	
	Z603041000	CABLE DE ALIMENTACION	POWER WIRING	1	1	1	1	
	Z203094000	CABLE DE ALIMENTACION	POWER WIRING	1	1	1	1	
	Z468901000	CABLE DE ALIMENTACION UK	POWER WIRING UK	1	1	1	1	
	Z258970000	CABLEADO FI30BBT	WIRING FI 30 B BT	1	1	1	1	
	Z203074000	INSTALACION ELECTRICA FI-30	ELECTRIC INSTALLATION FI-30	1	1	1	1	

vsezip.ru

+7(812)987-08-8

MOD.		LAVAVASOS	ZONA	CAMBIOS A REALIZAR PARA LA VERSION ADATEC					
ITEM	CODIGO	DENOMINACION	TEXTO	LABP-300B - BT	AQUATEC RAPI				
		<b>PIEZAS A ELIMINAR</b>	<b>DELETE PARTS</b>						
S/Nº	Z208769000	ADHESIVO ASBER LABP-300B -BT	ADHESIVE ASBER LABP-300B -BT	1	-				
	Z206136000	FOLLETO DE INSTRUCCIONES	INSTRUCTION LEAFLET	1	-				
		<b>PIEZAS A INTRODUCIR</b>	<b>PARTS TO ENTER</b>						
S/Nº	Z204404000	ADHESIVO AQUATEC RAPIDE	ADHESIVE AQUATEC RAPIDE	-	1				
	Z444405000	FOLLETO INSTRUCCIONES	INSTRUCTION LEAFLET.	-	1				

FI-30, Fv34C, Gx14C, Lp300C, Rp14C, A320, Fi-30T, KM-30, CLV-30, BYM-500, EMP-500, DE

Зип Общедит

sezip.ru

+7(812)987-08-81

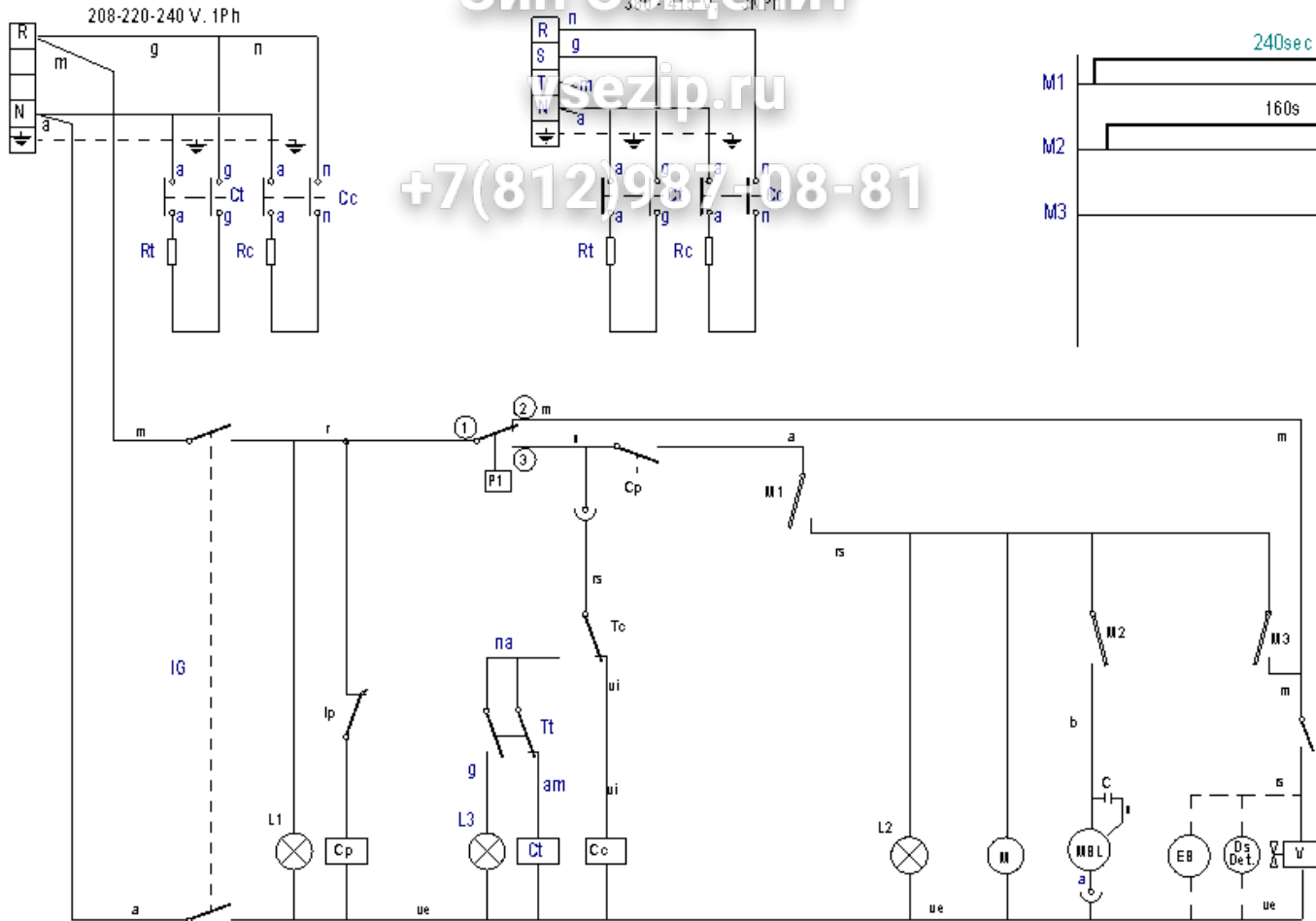

Esquema Teorico FI-30		
Nº	Pieza	
Nº	Modificación	
①	D&M-600 te its bas arto	
②	MOVIL FPIT mode lo a sar to	
③	ASC-30 ASCASO mode lo a sar to	
Firma		Fecha
Dibujado M. Mallo		07-10-2005
Proyectado M. Mallo		07-10-2005
Comprobado <i>gubell</i>		07-10-2005
Escala		
Para hacer el cableado es necesario que		

# FI 30 B BT - LABP-30

Зип.Общепит

vsezip.ru

+7(812)987-08-81

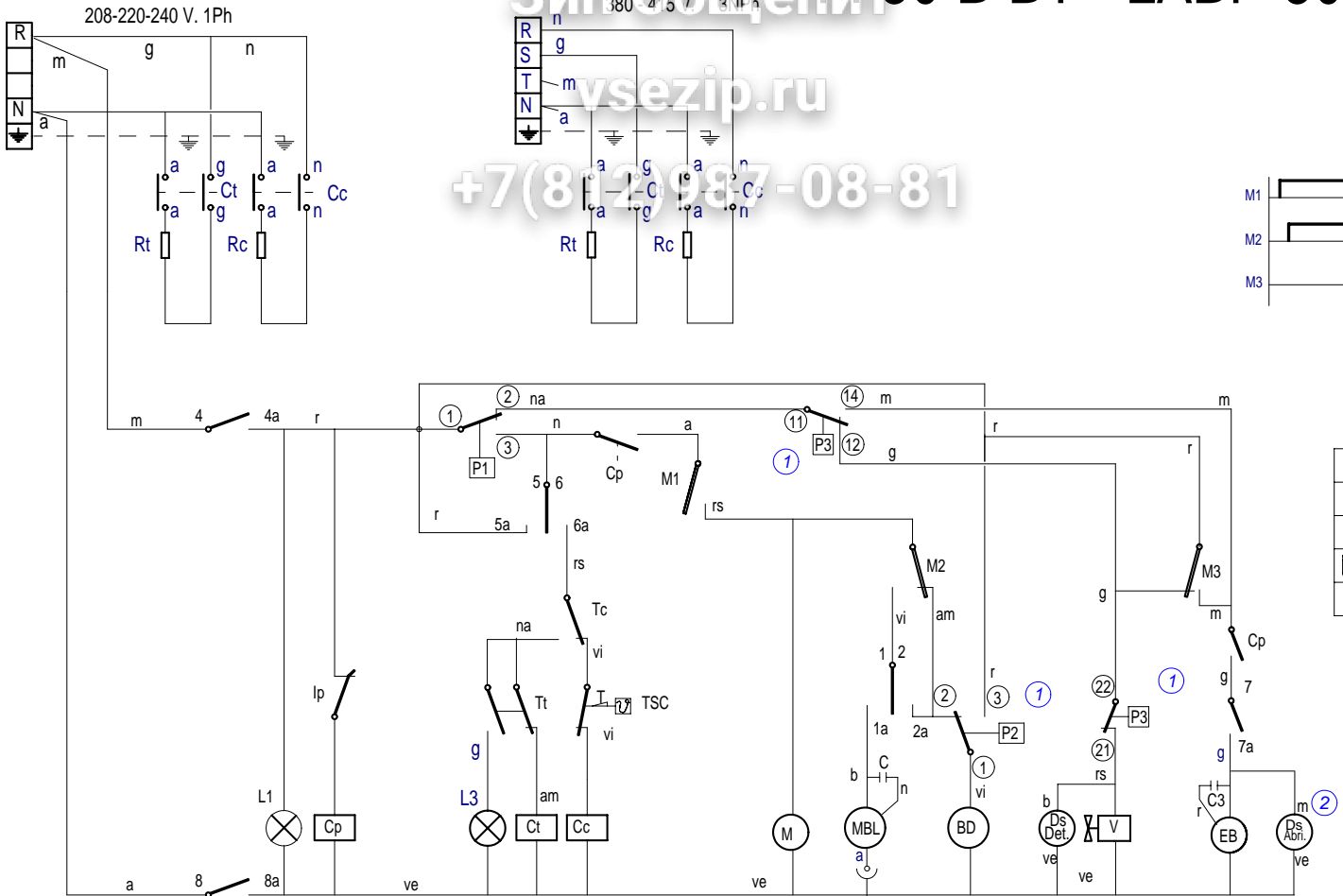

Esquema Teorico FI 30 B BT

Nº	Pieza	
Nº	Modificacion	
1	Se sustituyen P3, P4 y P5 por el triple pres	
2	Introducir bomba peristaltica para abrillanta	
Firma		Fecha
Dibujado		M.Maillo 18-01-2007
Proyectado		M.Maillo 18-01-2007
Comprobado		18-01-2007
Escala		
<p style="text-align: right;">L</p> <p style="text-align: right;">Plano hau ez daiteke erabili ez berizita gure</p>		





Зип Общепит  
vsezip.ru  
+7(812)937-0831

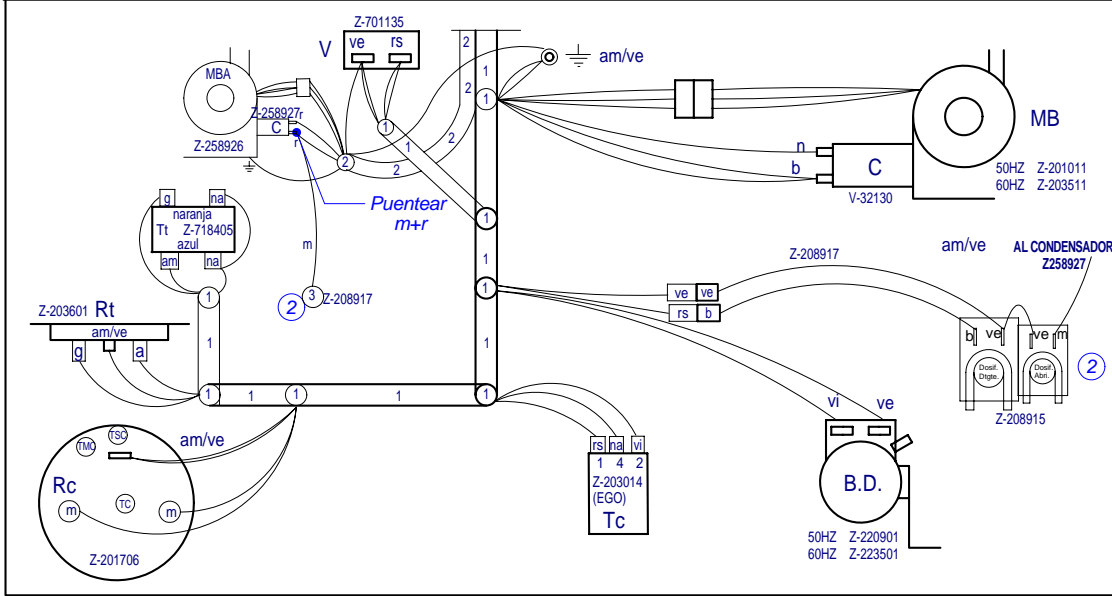
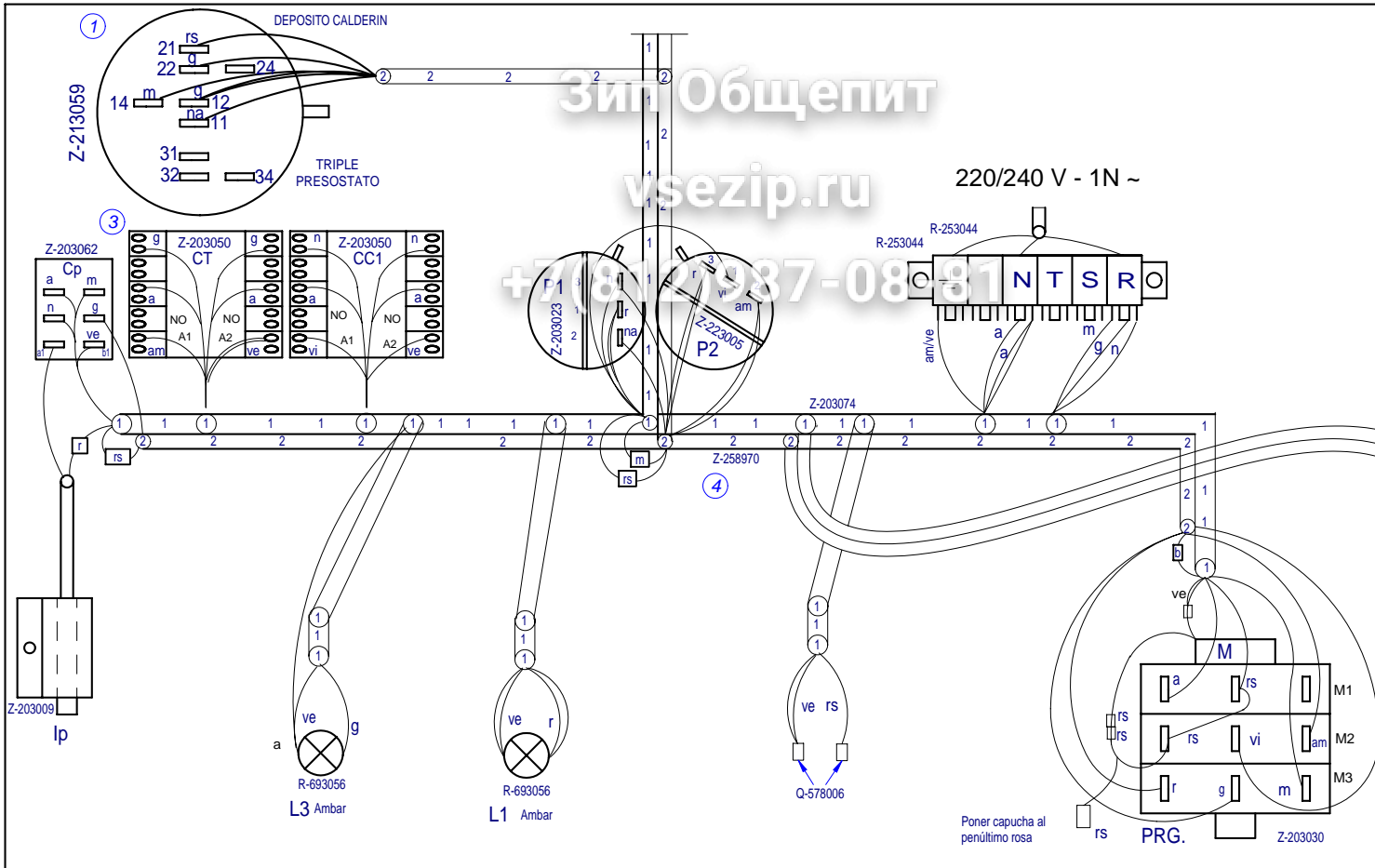

Plano Montaje FI 30 B BT		
Nº	Pieza	
Nº	Modificacion	
1	Presostato hiruokitza sartu	
2	Introducir bomba peristaltica doble y cableado	
3	Ci-ren erreferentzia aldatuta, Z203050 kendu da eta Z2	
4	ACTUALIZACION	
	Firma	Fecha
Dibujado	M.Maillo	19-01-2007
Proyectado	M.Maillo	19-01-2007
Comprobado		19-01-2007
Escala		
		O
		Plano hau ez daiteke erabili ez berritza gure

# LEYENDA APERTURA FRONTAL

	ESPAÑOL	FRANÇAIS	ENGLISH	DEUTSCH
BD	Bomba desagüe	Pompe de vidage	Drain pump	Abflußpumpe
C 1/2/3	Condensador	Condensateur	Condenser	Kondensator
CMB	Contactora bomba lavado	Contacteur pompe lavage	Wash pump contactor	Kontaktschütz Waschpumpe
Cc 1/2	Contactora calentamiento calderin	Contacteur chauff. surchauffeur	Boiler heating contactor	Kontaktschütz Boilerheizung
Ct	Contactora calentamiento tanque	Contacteur chauffage cuve	Tank heating contactor	Kontaktschütz Heizung Tank
CP	Rele puerta	Relais porte	Door relay	Türrelais
Ds.Det.	Dosificador detergente	Dosueur de detergent	Detergent doser	Dosierer Spülmittel
E.B	Electrobomba de presion	Electropompe de pression	Electric pressure pump	Elektro-Drucksteigerungspumpe
IG	Interruptor general	Interrupteur general	Main switch	Hauptschalter
IP	Micro puerta	Micro porte	Door microswitch	Mikroschalter Tür
L1	Piloto de encendido	Voyant fonctionnement	Operation light	Betriebsanzeigelampe
L2	Piloto marcha	Voyant demarrage	Start light	Startanzeigelampe
L3	Piloto maquina preparada	Voyant machine prêt	Light machine ready	Betriebsbereitschaftsanzeige
MBL	Bomba lavado	Pompe lavage	Wash pump	Waschpumpe
M	Motor programador	Moteur du programmeur	Motor programmer	Motor Programmiervorrichtung
M Av. R	Motor program. avance rapido	Moteur du progr.avance rapide	Motor program. rapid advance	Motor Programmiervorrich. so
M1	Micro programador marcha	Micro du programm. de marche	Micro programmer on	Motor Programmiervorrich. Be
M2	Micro programador lavado	Micro du programm. de lavage	Micro programmer wash	Motor Programmiervorrich. W
M3	Micro programador aclarado	Micro du programm. de rinçage	Micro programmer on	Motor Programmiervorrich. Sp
M4	Micro programador Termo-stop	Micro du programm. Thermo-stop	Micro programmer Thermo-stop	Motor Programmiervorrich. Th
M5	Micro programador avance	Micro du programm. avance	Micro programmer advance	Motor Programmiervorrich. V
P, P1, P5	Presostato	Pressostat	Pressure switch	Druckwächter
P2, P3, P4	Presostato limitador	Pressostat de sécurité	Hi-limit pressure switch	Begrenzer Druckwächter
RC	Resistencia calderin	Resistance surchauffeur	Boiler heating element	Heizwiderstand Boiler
RT	Resistencia tanque	Resistance cuve	Tank heater	Heizwiderstand Tank
Tt	Termostato tanque	Thermostat de cuve	Tank thermostat	Thermostat Tank
TC	Termostato calderin	Thermostat surchauffeur	Boiler thermostat	Thermostat kessel
TSC	Limitador calderin	Limiteur surchauffeur	Boiler Hi-limit	Begrenzer Boiler
TSTP	Termostato termo-stop	Thermostat Thermo-stop	Thermo-stop Thermostat	Thermostat Thermo-stop
V	Electrovalvula llenado y aclarado	Electrovan. remplissage rinçage	Fill and rinse valve	Elektroventil Füllen und Spülen
<b>COLOR</b>	<b>COLORES</b>	<b>COULEURS</b>	<b>COLOUR</b>	<b>FARBEN</b>
a =	Azul	Bleu	Blue	Blau
am =	Amarillo	Jaune	Yellow	Gelb
am/ve =	Amarillo/verde	Jaune / vert	Yellow / green	Gelb/grün
b =	Blanco	Blanc	White	Weiß
g =	Gris	Gris	Grey	Grau
m =	Marrón	Marron	Brown	Braun
n =	Negro	Noir	Black	Schwarz
na =	Naranja	Orange	Orange	Orange
r =	Rojo	Rouge	Red	Rot
rs =	Rosa	Rose	Pink	Rosa
ve =	Verde	Vert	Green	Grün
vi =	Violeta	Violet	Purple	Violett