

**ATTENZIONE:** PER TENSIONI SPECIALI, SPECIFICARE SEMPRE IL MODELLO DI FORNO ED IL NUMERO DI MATRICOLA  
**ATTENTION:** FOR SPECIAL VOLTAGES, PLEASE ALWAYS SPECIFY THE OVEN MODEL AND THE SERIAL NUMBER

**ATTENTION:** POUR TENSIONS SPÉCIALES, MERCI DE SPÉCIFIER TOUJOURS LE MODÈLE DU FOUR ET LE NUMÉRO DE SÉRIE  
**ACHTUNG:** BEI SONDRERSPANNUNGEN, BITTE IMMER OFEN-MODELL UND SERIENNUMMER GEBEN.

ed. 0412

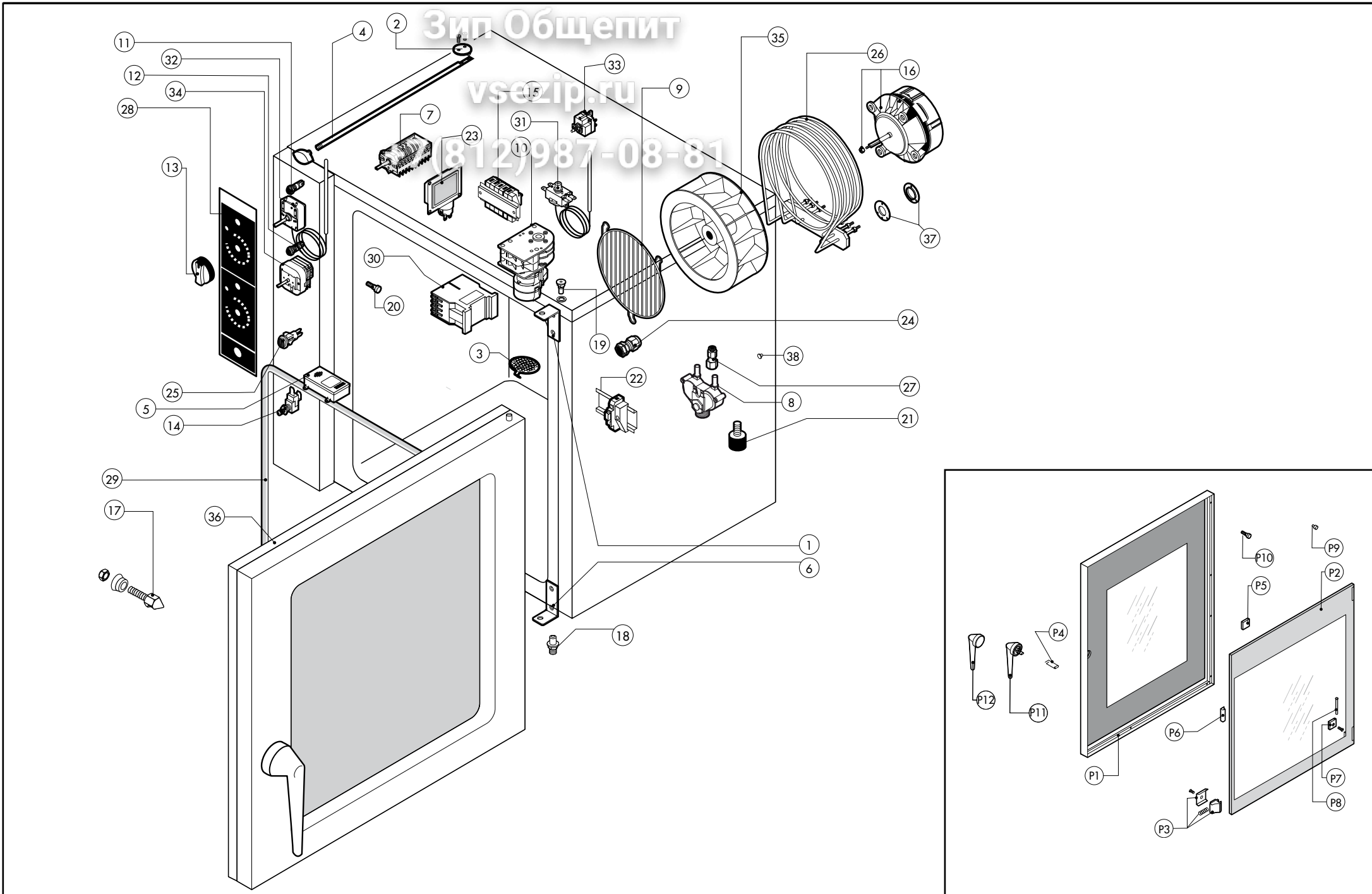

**TAV. A**

**REV 071 M**

POS.	COD.	Pz.	DESCRIZIONE	DESCRIPTION	BESCHREIBUNG	DESCRIPCIÓN
1	R17201110	1	ASS.CERNIERA SUPPORTA REC-REV-REP 2011	UPPER HINGE	CHARNIERE SUPERIEUR	BISAGRA SUPERIOR
2	R18200600	1	ASS.FARFALLA M_042/051 REV M	CHAMBER VENT PLATE	ENTFEUCHTUNGSSCHIEBER	DISCO RESPIRADERO
3	R18200710	1	ASS.FILTRO SCARICO M_042/051	DRAIN FILTER	FILTRE ENCEINTE	ABFLUSSFILTER
4	R58003560	1	ASTA SFIATO REV 051/071/101 M	CHAMBER VENT ROD	BARRE COMMANDE EVENT	SCHIEBERACHSE
5	R65330050	1	BUZZER TEMPOR.3" 230V C/SCAT.	BUZZER 3"	SONNERIE 3"	SUMMER MIT ZEITGLEID
6	R17403910	1	CERNIERA INF. PORTA REGOL.REC-REV-REP	LOWER HINGE	CHARNIERE INFERIEUR	UNTERES SCHARNIER
7	R65080020	1	COMMUTATORE 5 POS.-SERIE 71A COD.88.0900	MAIN SELECTOR SWITCH	COMMUTEUR	SCHALTER
8	R65110210	1	E.V. 2 VIE 220V 50HZ X J.G.CON ATTACC	SOLENOID VALVE 220V 50HZ	ELECTROVANNE 220V 50HZ	MAGNETVENTIL 220V 50HZ
9	R75300150	2	GRIGLIA VENTILATORE D.170	FAN GUARD GRID D.170	GRILLE VENTILATEUR D.170	VENTILATORSCHUTZGITTER D.170
10	R65090190	1	INVERSORE CICLICO 8'	REVERSING SWITCH	INVERSEUR	POLWENDER
11	R65270300	2	LUCE SPIA GIALLA ALPHATECH SL 656 TZB	ORANGE INDICATING LIGHT	LAMPE TEMOIN ORANGE	ORANGENE KONTROLLAMPE
12	R65270320	1	LUCE SPIA VERDE ALPHATECH SL 656 TZA	GREEN INDICATING LIGHT	LAMPE TEMOIN VERT	GRUENE KONTROLLAMPE
13	R69030130	3	MANOPOLA BLU/BLU D.42	KNOB KIT	POIGNEE COMMANDE	DREHKNOPF
14	R65260540	1	MICRO PORTA	DOOR SWITCH	MICRO PORTE	TUERSCHALTER
15	R65220091	1	MORSETTIERA LX2E (TIPO 2) NEW	TERMINAL BOARD	BORNIER	KLEMMLEISTE
16	R65041010	2	MOTORE 1F.200W 2VEL(C/COND.)C06110	MOTOR	MOTEUR	MOTOR
17	R69010260	1	NASELLO 1 STEP 6303-020022	DOOR LATCH 1 STEP	GACHE DE PORTE POUR OUVERTURE SIMPLE	SCHLIESSNASE 1 STUFE
18	R58002520	1	PERNO INF.CERNIERA REG. V/061-102	LOWER HINGE PIN	CHEVILLE CHARNIERE INFERIEURE	UNTERES SIE SCHARNIERSTIFT
19	R58002150	1	PERNO SUP.CERNIERA REG. M/106-220	UPPER HINGE PIN	CHEVILLE CHARNIERE SUPERIEURE	OBERES SCHARNIERSTIFT
20	R58001850	8	PERNO SUPP. PARATIE M5 MIXTER	RACK HOLDER	BOLZEN AUFLAGESCHIENEN	SUPPORT GLISSIERE
21	R69070220	4	PIEDINO INOX+NYLON D.40 H TOT.60 FIL.M10	FOOT	VERIN	ZYLINDRISCHER FUSS
22	R65210020	2	PORTAFUSIBILE BARRA DIN 5x20	FUSE CARRIER	PORTE-FUSIBLE	SICHERUNGSHALTER
23	R65270510	2	PORTALAMPADA STAGNO ALPHATECH 77.705.U10	WATERPROOF LIGHT SOCKET	DOUILLE ETANCHEE	DICHTE LAMPEHALTERUNG
24	R65240200	1	PRESSACAVO V-TEC 21 NERO	FAIRLEAD	PRESSE CABLE	ZUGENTLASTUNG
25	R65260520	1	PULSANTE COMANDO UMIDIFICATORE TIPO SPL60	HUMIDIFIER PUSH BUTTON	TOUCHE HUMIDIFICATEUR	BESCHWADUNGSDRUCKTASTE
26	R65011530	2	RESIST.6000W230V CAM. ALPHA	HEATING ELEMENT	RESISTANCE	HEIZKOERPER
27	R62090788	2	RIDUZIONE INTER.DRITTA ø10-ø6 PM201006E	REDUCTION	REDUCTION	VERRINGERUNG
28		1	TASTIERA	PLATE	PLAQUE	BEDIENUNGSFOLIE
29	R70044400	1	TELAIO GUARNIZIONE PORTA REV 071	FRONT GASKET	JOINT FACADE	DICHTUNG DER FRONTSEITE
30	R65140380	2	TELERUTTORE 3RT1016-1AP02	CONTACTOR	CONTACTEUR	SCHUETZ
31	R65070460	1	TERMOST.SICUR.BIP.360°C NEGAT.	THERMOSTAT	THERMOSTAT	THERMOSTAT
32	R65070400	1	TERMOSTATO 50/300°C KT 170 CLA	THERMOSTAT 50/300°C	THERMOSTAT 50/300°C	THERMOSTAT 50/300°C
33	R65070165	1	TERMOSTATO 65°C	THERMOSTAT 65°C	THERMOSTAT 65°C	THERMOSTAT 65°C
34	R65090090	1	TIMER ELETTR.120' C/POS.MAN.MS65 6935A	TIMER	MINUTERIE	ZEITSCHALTUHR
35	R75400410	2	VENTOLA D.180X77/12 50HZ P.D.	FAN	TURBINE	LUEFTERRAD
36	R17102710	1	PORTA COMPLETA REV-RGV071 LX-AT	DOOR ASSEMBLY	PORTE COMPLETE	TUER KOMPLETT
37	R58005500	2	FLANGIA GUARNIZIONE MOTORE	MOTOR GASKET BRASS FLANGE	BRIDE JOINT MOTEUR	FLANSCH F. MOTORDICHTUNG
38	R65110500	2	REGOL. PORT. MARR. ATCH. 10L/h	10 LT/H WATER FLOW REDUCER	REGULATUER DE DEBIT 10 LT.	DURCHFLOSSMONDERER 10L/STD.

