

Зип Общепит

vsezip.ru

+7(812)987-08-81

# WAREWASHER

ELECTRONICAL SWITCHES  
DOUBLE BODY VERSION

TYPE: 109E

Accessories  
BOOSTER PUMP  
DETERGENT DISPENSER

---

## Spare Parts Manual

---



**INFORMAZIONI GENERALI**

Questo catalogo serve per richiedere con esattezza le parti di ricambio

Nelle ordinazioni indicare:

1) il numero dei codici dei particolari seguito dalla descrizione e la quantità desiderata;

2) Il codice alfa-numerico presente nella seconda colonna della tabella ;

**I disegni delle parti di ricambio sono solo indicativi e non rappresentano il pezzo in oggetto.**

**I dati contenuti in questo catalogo sono indicativi e possono essere soggetti a modifiche senza impegno di preavviso.**

**ALLGEMEINE INFORMATIONEN**

Dieser Ersatzteilkatalog dient zur genauen Angabe der Teile bei Ersatzteilbestellungen.

Bei Ersatzbestellung ist folgendes anzugeben:

1) Die Bestellnummer der Ersatzteile mit der entsprechenden Beschreibung genaue Menge;

2) Der alpha-numerischer Code auf der zweiten Reihe in dein Schuld;

**Die Zeichnungen der Ersatzteile sind nur als Hinweise gedacht und stellen nicht das betroffene Teil dar.**

**Bei den im Katalog angeführten Daten handelt es sich um Anhaltsdaten, die jederzeit, ohne Vorankündigung, geändert werden können.**

**GENERAL INFORMATION**

The present spare parts order exactly the right spare parts

When ordering specify:

1) the part's code number followed by its description and quantity needed;

2) The alpha-numeric code is in the second column in the chart;

**Spare parts drawings are general and do not represent the part.**

**The contents of this catalogue are general and can undergo changes without prior notice.**

**INFORMACIONES GENERALES**

El presente catálogo sirve para pedir con exactitud las partes de repuesto

En los pedidos se debe indicar:

1) el número de código de la parte y a continuación la descripción cantidad deseada;

2) El código alfanumerico presente en la segnada columna de la tabla;

**Los diseños de las partes de recambio son solo indicativos y no representan la pieza en cuestión.**

**Los datos contenidos en el presente catálogo son indicativos y pueden modificarse sin aviso previo.**

**INFORMATIONS GENERALES**

Ce catalogue permet de commander correctement les pièces détachées

Les commandes doivent être passées en indiquant:

1) le numero de code des pièces détachées suivi de leur description quantité désirée;

2) le code alphanumérique dans la deuxième colonne du tableau;

**Les plans des pièces détachées sont fournis seulement à titre indicatif et ne représentent pas la pièce concernée.**

**Les données de ce catalogue sont citées seulement à titre indicatif et peuvent être l'objet de modifications sans avis préalable.**

**ESEMPIO  
EXAMPLE  
EXEMPLE  
BEISPIEL**

Rif.	Codici
MODULE:Particolari	
10505	540903
10510	540908
10515	15065/A
10520	540086
10525	540028



**Note**

Tutte le informazioni riportate si intendono aggiornate alla data di stampa. Il Produttore si riserva il diritto di apportare qualsiasi modifica richiesta dallo sviluppo evolutivo dei suddetti prodotti.

Per la sicurezza, la garanzia, l'affidabilità ed il valore della lavastoviglie usa solo ricambi originali. **Per alcuni codici, sono richieste quantità minime d'ordine.**



**Attenzione**

Questo libretto è parte integrante della lavastoviglie e, in caso di passaggio di proprietà, deve essere consegnato al nuovo acquirente.



**Remarque**

Toutes les informations contenues dans ce manuel s'entendent mises à jour à la date d'impression. En raison du développement constant de ses produits, usine se réserve le droit d'apporter à tout instant les modifications qu'elle jugera utiles.

Pour la sécurité, la garantie, la fiabilité et la valeur de votre lavevaisselles n'utilisez que des pièces de rechange d'origine. **Pour quelque référence on demande un minimum de pièces par commande**



**Attention**

Ce manuel doit être considéré comme partie intégrante de la lavevaisselles, en cas de transfert de propriété, doit toujours être remis au nouveau propriétaire.



**Note**

The information contained herein is valid at the time of going to print. The Company reserves the right to make any changes required by the future development of the above-mentioned products.

For your safety, as well as to preserve the warranty reliability and worth of your dishwashers, use original spare parts only. **For some codes a minimum quantity for order is required.**



**Warning**

This manual forms an integral part of the dishwashers and - if a transfer of title occurs - must always be handed over to the new owner.



**Hinweis**

Die Der Hersteller behält sich das Recht vor, jegliche, durch eine Weiterentwicklung der genannten Produkte bedingte Änderungen vornehmen zu können.

Verwenden Sie für Ihre Sicherheit, die Garantie, die Zuverlässigkeit und den Wert Ihrer machine originale Ersatzteile. **Für bestimmte Code nummer werden mindesten bestellungen verlangt.**



**Achtung**

Diese Betriebsanleitung ist Bestandteile des machine und muss bei seinem Weiterverkauf dem neuen Besitzer ausgehändigt werden.



+7(812)987-08-81



**Code** DW 999XXYYYY **CL/Part**

**Model DESCRIPTION**

**S/N** DW A 1015770 Type .....

400V 3N 50HZ 8A  
3500W 500W

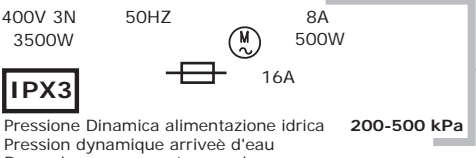
 16A

**IPX3**

Pressione Dinamica alimentazione idrica 200-500 kPa  
Pression dynamique arrivée d'eau  
Dynamic pressure water supply  
Dynamischer Druck asserreinlauf

Pressione dinamica vapore saturo  
Pression dynamique vapore satueèè  
Dymanischer Druck gesattigter Dampf  
Pression Dinamica Vapor Saturado

**TECHICAL SPECIFICATION**



**MADE IN ITALY**

Temperatura massima acqua in ingresso 60°C  
Temperature max eau a l'entre  
Maximale Temperatur Wasseranschlü  
Maximum Water temperature in-feeding

Model 

S/N 



Spare parts

---

**Зип Общепит**

**vsezip.ru**

**+7(812)987-08-81**

vsezip.ru

+7(812)987-08-81

## 1. Spare parts

General body parts.....	9
General parts heat recovery .....	11
Lockup system .....	13
Control panel and switches.....	15
Electronic control HACCP .....	17
Electric control components.....	19
Solenoid valve group .....	21
Rinse with steady temperature.....	23
Rinse aid dispenser group.....	25
Wash pump .....	27
Dosing detergent group.....	29
Pressure switch group with air trap ...	31
Wash and rinse group .....	33
Motorgear components .....	35
Basket rotating system .....	37
Accessory.....	39

vsezip.ru

+7(812)987-08-81

## 1.1 Voltage codes

Volt	Voltage code
A	3/N/PE~380-400V 50-60Hz
D	3/PE~200-210V 50-60Hz
F	2/PE~220-240V 50-60Hz
G	3/N/PE~415V 50-60Hz
H	3/PE~220-230V 50-60Hz
K	3/PE~380-400V 50-60Hz
L	3/PE~415V 50-60Hz
M	3/PE~440V 60Hz
P	1/N/PE~220-230V 50-60Hz
R	2/PE~220-240V 50-60Hz
U	1/N/PE~240V 50-60Hz
V	3/PE~240V 50-60Hz
W	1/N/PE~100-110V 50-60Hz

## 1.2 Product codes

Product code	Full name
Model codes	
e	ELECTRONICAL SWITCHES
dc	DOUBLE BODY VERSION
Type codes	
109E	109E
Accessory codes	
bp	BOOSTER PUMP
dd	DETERGENT DISPENCER

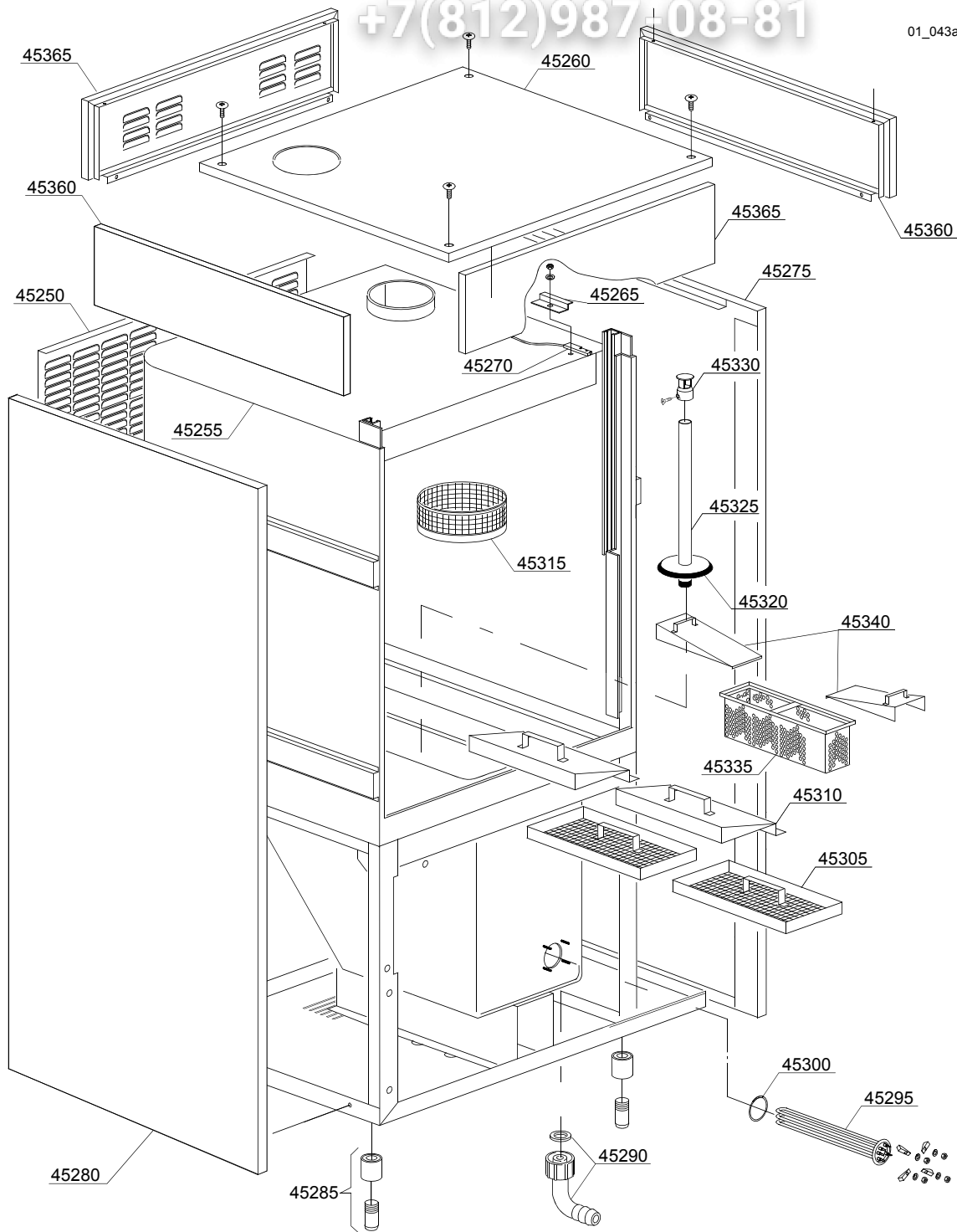



ID	P-code	SN from	SN to	Mod.	Acces.	Volt	Description
<b>Module:General body parts</b>							
45250	96503		-	e,dc			Back panel
45255	96500		-	e,dc			Body with complete door
45260	96517		-	e,dc			Tank
45265	3009112		-	e,dc			Support microswitch
45270	3003112		-	e,dc			Door microswitch
45275	96501		-	e,dc			Right lower panel
45280	96502		-	e,dc			Left lower panel
45285	15116		-	e,dc			Foot
45285	80116/M		-	e,dc			"Marina" foot
45290	15613		-	e,dc			Elbow 1/4"
45295	30001011		-	e,dc		A,H,K,L,P,R,U,V	Heating element 9000/9800W 230 / 240V 3
45300	13015		-	e,dc			O-ring 6225 OR 160 NBR
45305	96506		-	e,dc			Surface filter
45310	96507		-	e,dc			Slide for filter
45315	96119		-	e,dc			Filter for fireplace
45320	11600002		-	e,dc			Packing to flange
45325	96124		-	e,dc			Overflow pipe tube
45330	11600019		-	e,dc			End overflow pipe tube
45335	96508		-	e,dc			Inox rack collections granules
45340	96509		-	e,dc			Slide collections granules
45360	96516		-	e,dc			Side dx/sx
45365	96518		-	e,dc			Front/back fastening panel

e=ELECTRONICAL SWITCHES, dc=DOUBLE BODY VERSION, uw=LOWER AND UPPER VERSION

109E=109E

bp=BOOSTER PUMP, dd=DETERGENT DISPENSER

A=3/N/PE~380-400V 50-60Hz, D=3/PE~200-210V 50-60Hz, F=2/PE~220-240V 50-60Hz, G=3/N/PE~415V 50-60Hz, H=3/PE~220-230V 50-60Hz, K=3/PE~380-400V 50-60Hz, L=3/PE~415V 50-60Hz, M=3/PE~440V 60Hz, P=1/N/PE~220-230V 50-60Hz, R=2/PE~220-240V 50-60Hz, U=1/N/PE~240V 50-60Hz, V=3/PE~240V 50-60Hz, W=1/N/PE~100-110V 50-60Hz

vsezip.ru

+7(812)987-08-81

01\_043be

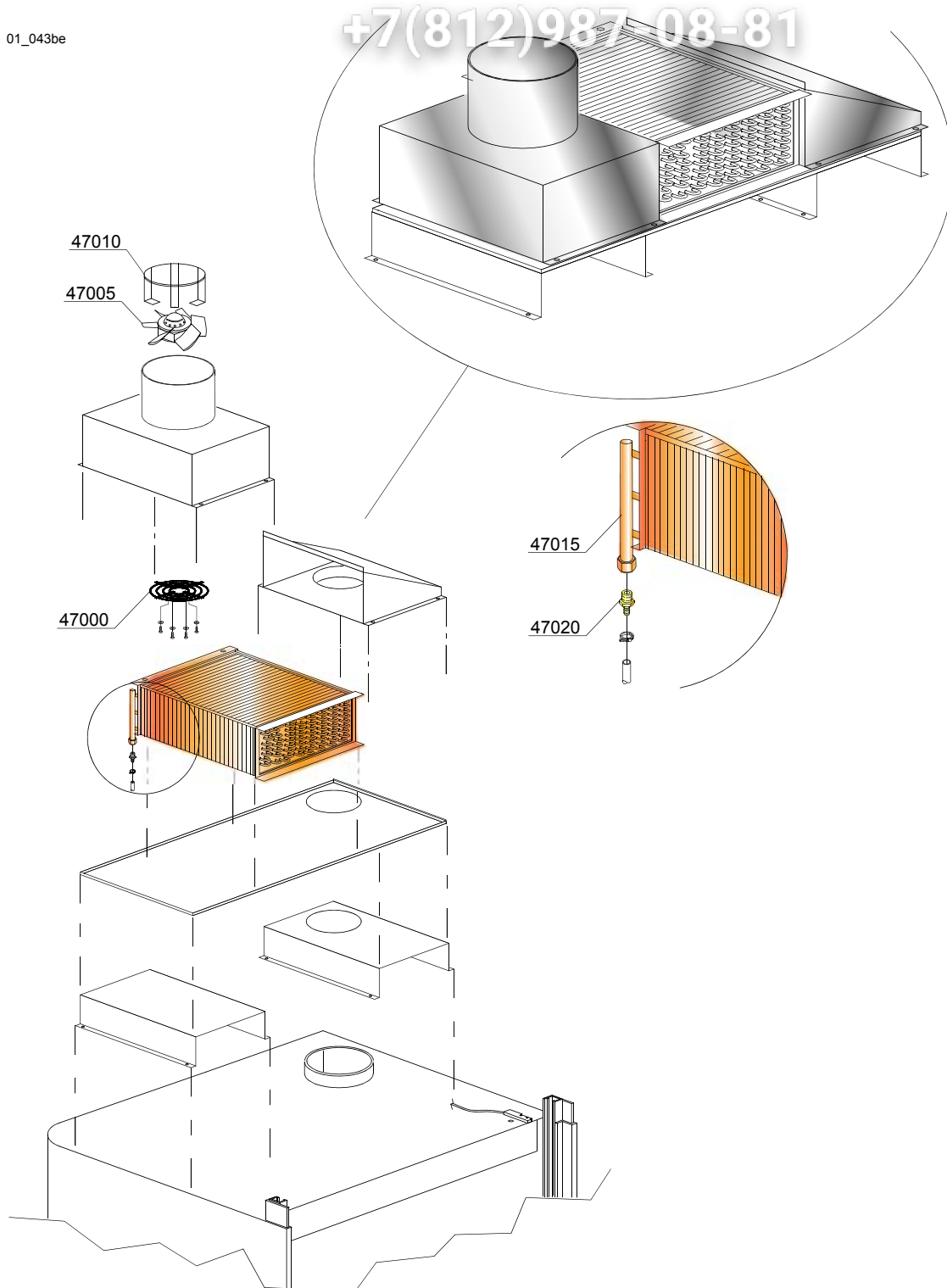

vsezip.ru

ID	P-code	SN from	SN to	Mod.	Acces	Volt	Description
<b>Module: General parts heat recovery</b>							
47000	96121		-	e,dc			Grill+fan support
47005	96120		-	e,dc			Fan 230 / 240 V 50-60- Hz
47005	96120/A		-	e,dc			Fan 440 V 60 Hz
47010	96014		-	e,dc			Motor fan support
47015	96519		-	e,dc			Heating recovery battery
47020	12023		-	e,dc			Hose holder

e=ELECTRONICAL SWITCHES, dc=DOUBLE BODY VERSION, uw=LOWER AND UPPER VERSION

109E=109E

bp=BOOSTER PUMP, dd=DETERGENT DISPENSER

A=3/N/PE~380-400V 50-60Hz, D=3/PE~200-210V 50-60Hz, F=2/PE~220-240V 50-60Hz, G=3/N/PE~415V 50-60Hz, H=3/PE~220-230V 50-60Hz, K=3/PE~380-400V 50-60Hz, L=3/PE~415V 50-60Hz, M=3/PE~440V 60Hz, P=1/N/PE~220-230V 50-60Hz, R=2/PE~220-240V 50-60Hz, U=1/N/PE~240V 50-60Hz, V=3/PE~240V 50-60Hz, W=1/N/PE~100-110V 50-60Hz

vsezip.ru

+7(812)987-08-81

02\_131\_e

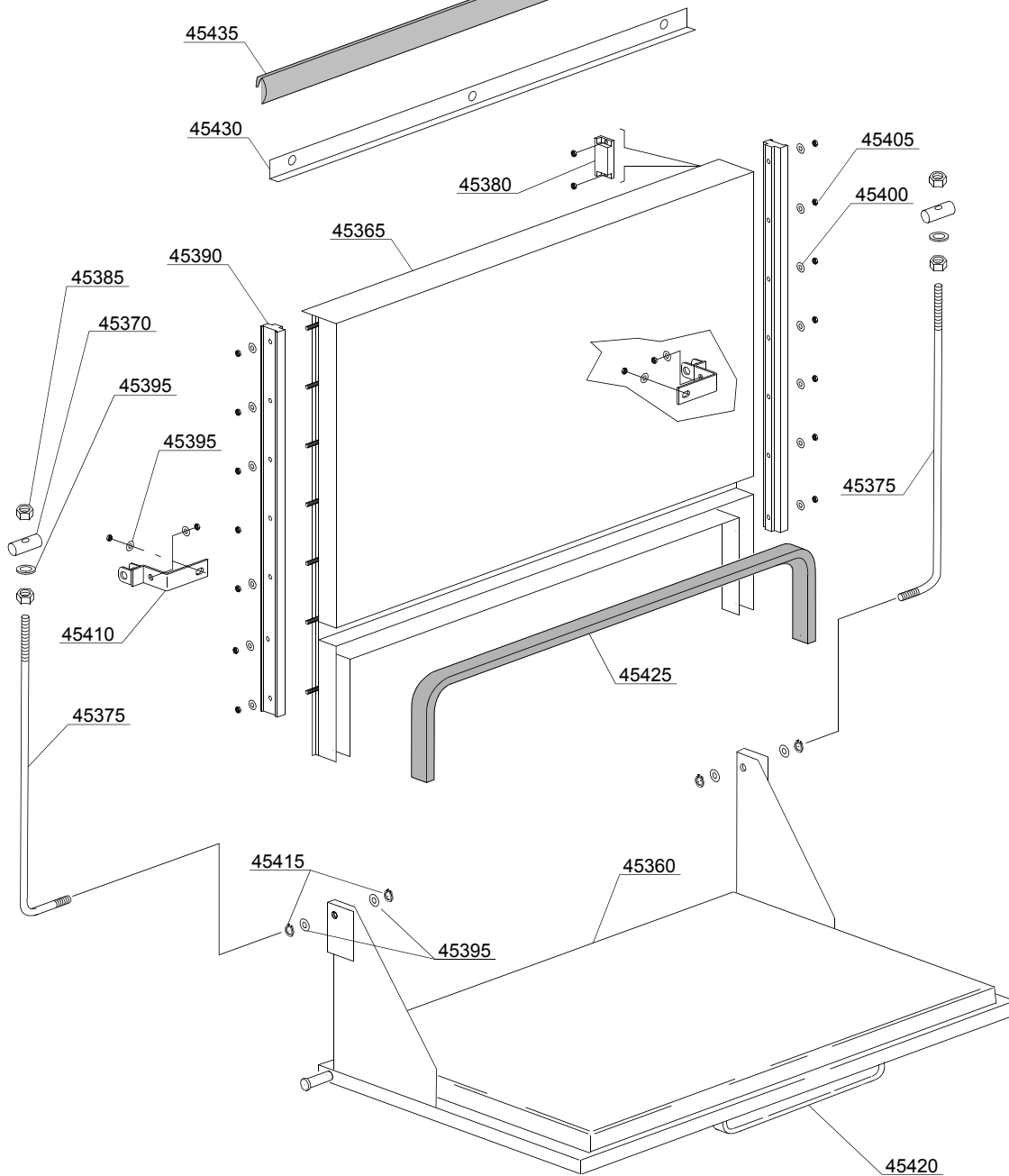

vsezip.ru

ID	P-code	SN from	SN to	Mod	Acces	Volt	Description
<b>Module: Lockup system</b>							
45360	96500/A		-	e,dc			Lower door
45365	96500/B		-	e,dc			Upper door
45370	22219		-	e,dc			Door rod pin
45375	96640		-	e,dc			Door rod
45380	80232		-	e,dc			Reed magnet
45385	11721		-	e,dc			Nut (minnum 10 pieces)
45390	96629		-	e,dc			Slide for door
45395	11177		-	e,dc			Ø6x12 Plain washer (minimum 10 pieces)
45400	11176		-	e,dc			Ø 5 Plain washer (minimum 20 pieces)
45405	11169		-	e,dc			M5 inox-nut (minnum 10 pieces)
45410	90916		-	e,dc			Door movement support
45415	11815		-	e,dc			Ø8 stainless steel snap ring (minimum 5 pieces)
45420	80750		-	e,dc			Stainless steel handle
45425	96134		-	e,dc			Door gasket ( mt 1,9 )
45430	96015		-	e,dc			Support profile packing
45435	96132		-	e,dc			Door gasket ( mt 1,15 )

e=ELECTRONICAL SWITCHES, dc=DOUBLE BODY VERSION, uw=LOWER AND UPPER VERSION

109E=109E

bp=BOOSTER PUMP, dd=DETERGENT DISPENCER

A=3/N/PE~380-400V 50-60Hz, D=3/PE~200-210V 50-60Hz, F=2/PE~220-240V 50-60Hz, G=3/N/PE~415V 50-60Hz, H=3/PE~220-230V 50-60Hz, K=3/PE~380-400V 50-60Hz, L=3/PE~415V 50-60Hz, M=3/PE~440V 60Hz, P=1/N/PE~220-230V 50-60Hz, R=2/PE~220-240V 50-60Hz, U=1/N/PE~240V 50-60Hz, V=3/PE~240V 50-60Hz, W=1/N/PE~100-110V 50-60Hz

vsezip.ru

+7(812)987-08-81

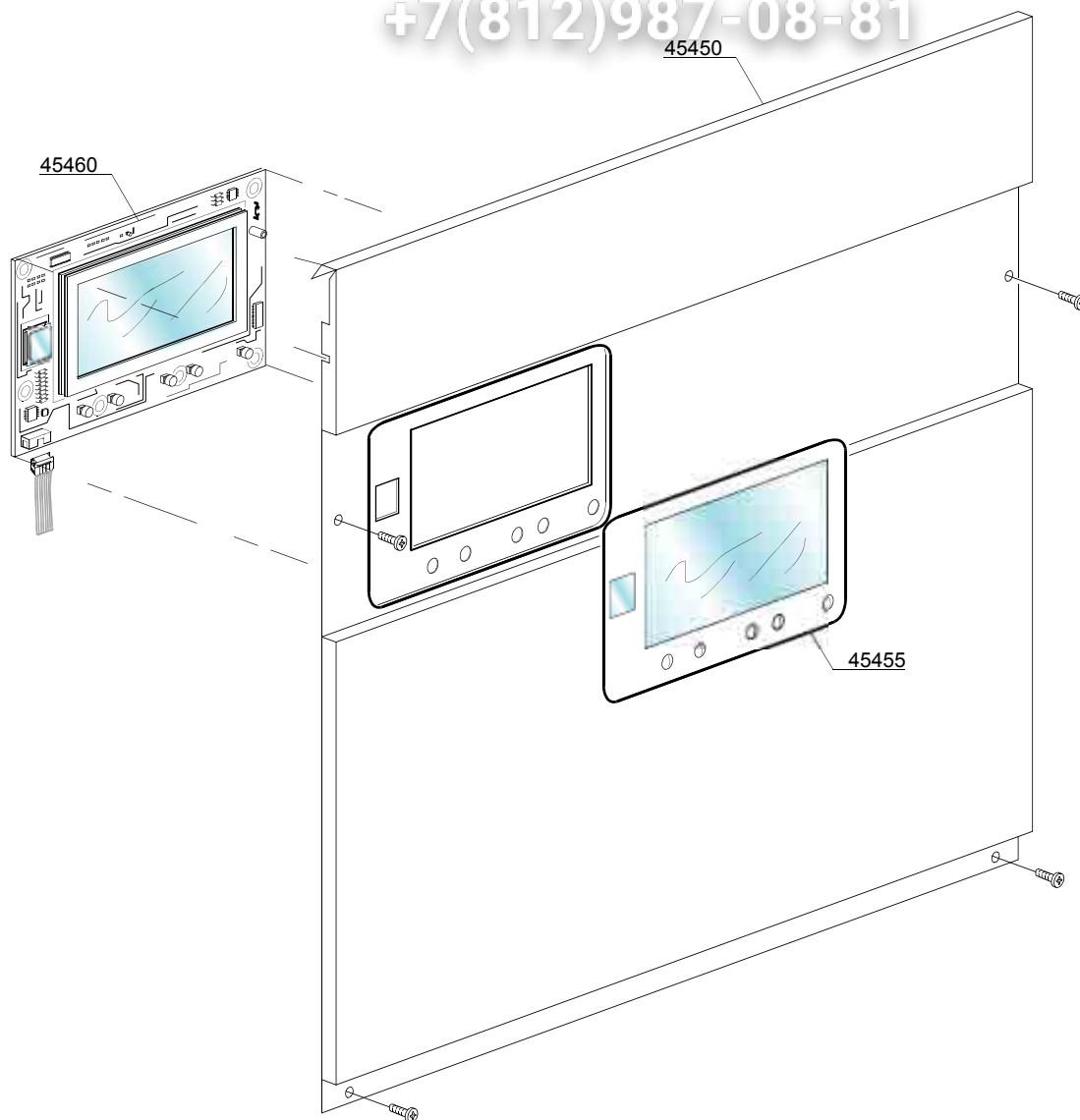

03\_064be

vsezip.ru

ID	P-code	SN from	SN to	Mod.	Acces	Volt	Description
<b>Module:Control panel and switches</b>							
45450	96505		-	e			Control panel
45455	96704		-	e			Silkscreen processed grill membrane push button-driver GR/09 (D)
45455	96706		-	e			Neutral silkscreen processed grill membrane push button-driver GR/09 (N)
45455	96705		-	e			Silkscreen processed grill membrane push button-driver GR/09 (K)
45455	96708		-	e			Silkscreen processed grill membrane push button-driver GR/09 (F)
45460	50650		-	e			Compleat push button-driver

e=ELECTRONICAL SWITCHES, dc=DOUBLE BODY VERSION, uw=LOWER AND UPPER VERSION

109E=109E

bp=BOOSTER PUMP, dd=DETERGENT DISPENCER

A=3/N/PE~380-400V 50-60Hz, D=3/PE~200-210V 50-60Hz, F=2/PE~220-240V 50-60Hz, G=3/N/PE~415V 50-60Hz, H=3/PE~220-230V 50-60Hz, K=3/PE~380-400V 50-60Hz, L=3/PE~415V 50-60Hz, M=3/PE~440V 60Hz, P=1/N/PE~220-230V 50-60Hz, R=2/PE~220-240V 50-60Hz, U=1/N/PE~240V 50-60Hz, V=3/PE~240V 50-60Hz, W=1/N/PE~100-110V 50-60Hz

vsezip.ru

+7(812)987-08-81

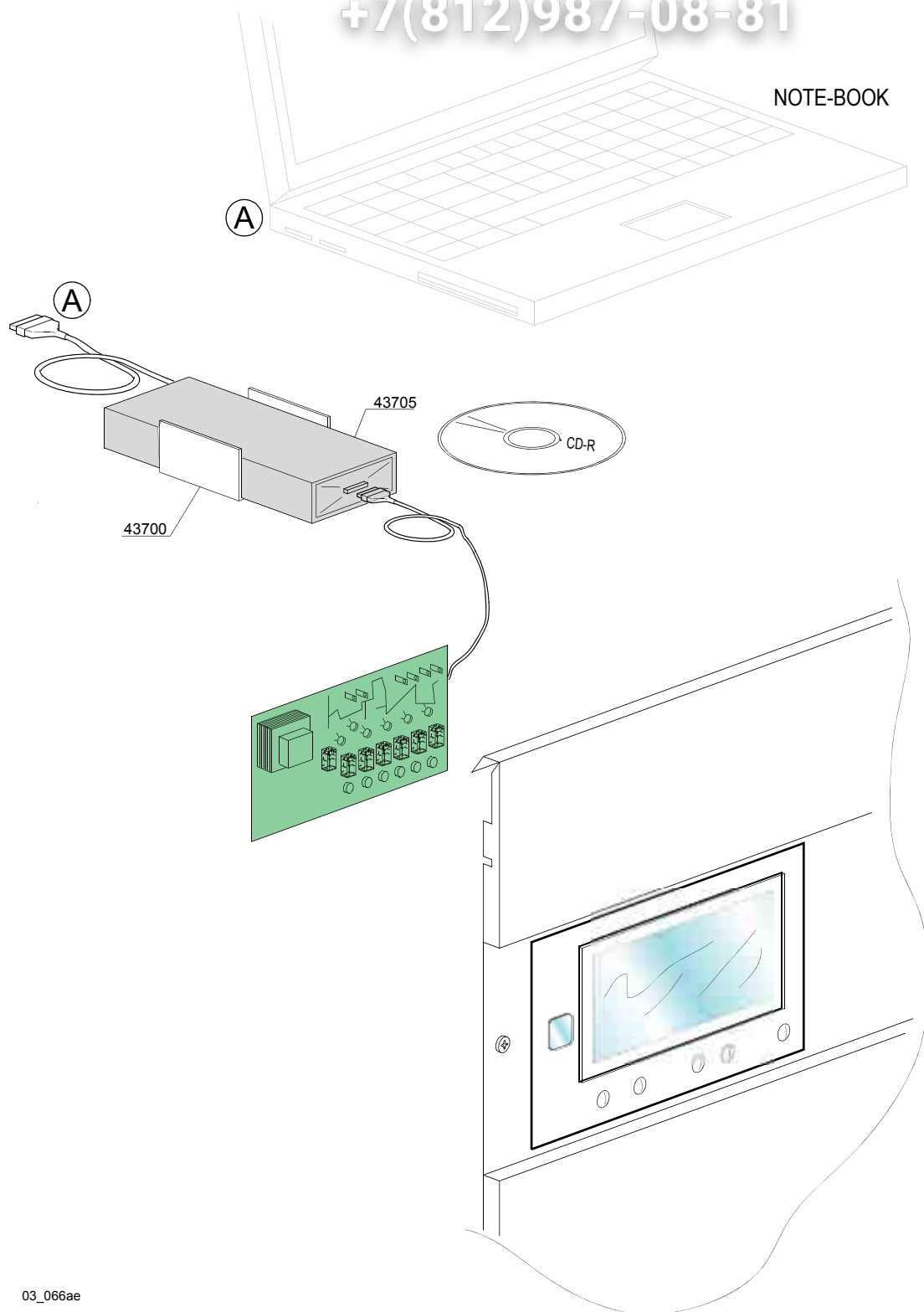

03\_066ae



vsezip.ru

ID	P-code	SN from	SN to	Mod.	Acces.	Volt	Description
<b>Module:Electronic control HACCP</b>							
43700	3060200		-	e			Support DATA-LOGGER
43705	99910217		-	e			Kit remote control HACCP

e=ELECTRONICAL SWITCHES, dc=DOUBLE BODY VERSION, uw=LOWER AND UPPER VERSION

109E=109E

bp=BOOSTER PUMP, dd=DETERGENT DISPENSER

A=3/N/PE~380-400V 50-60Hz, D=3/PE~200-210V 50-60Hz, F=2/PE~220-240V 50-60Hz, G=3/N/PE~415V 50-60Hz, H=3/PE~220-230V 50-60Hz, K=3/PE~380-400V 50-60Hz, L=3/PE~415V 50-60Hz, M=3/PE~440V 60Hz, P=1/N/PE~220-230V 50-60Hz, R=2/PE~220-240V 50-60Hz, U=1/N/PE~240V 50-60Hz, V=3/PE~240V 50-60Hz, W=1/N/PE~100-110V 50-60Hz

vsezip.ru

+7(812)987-08-81

04\_041\_e

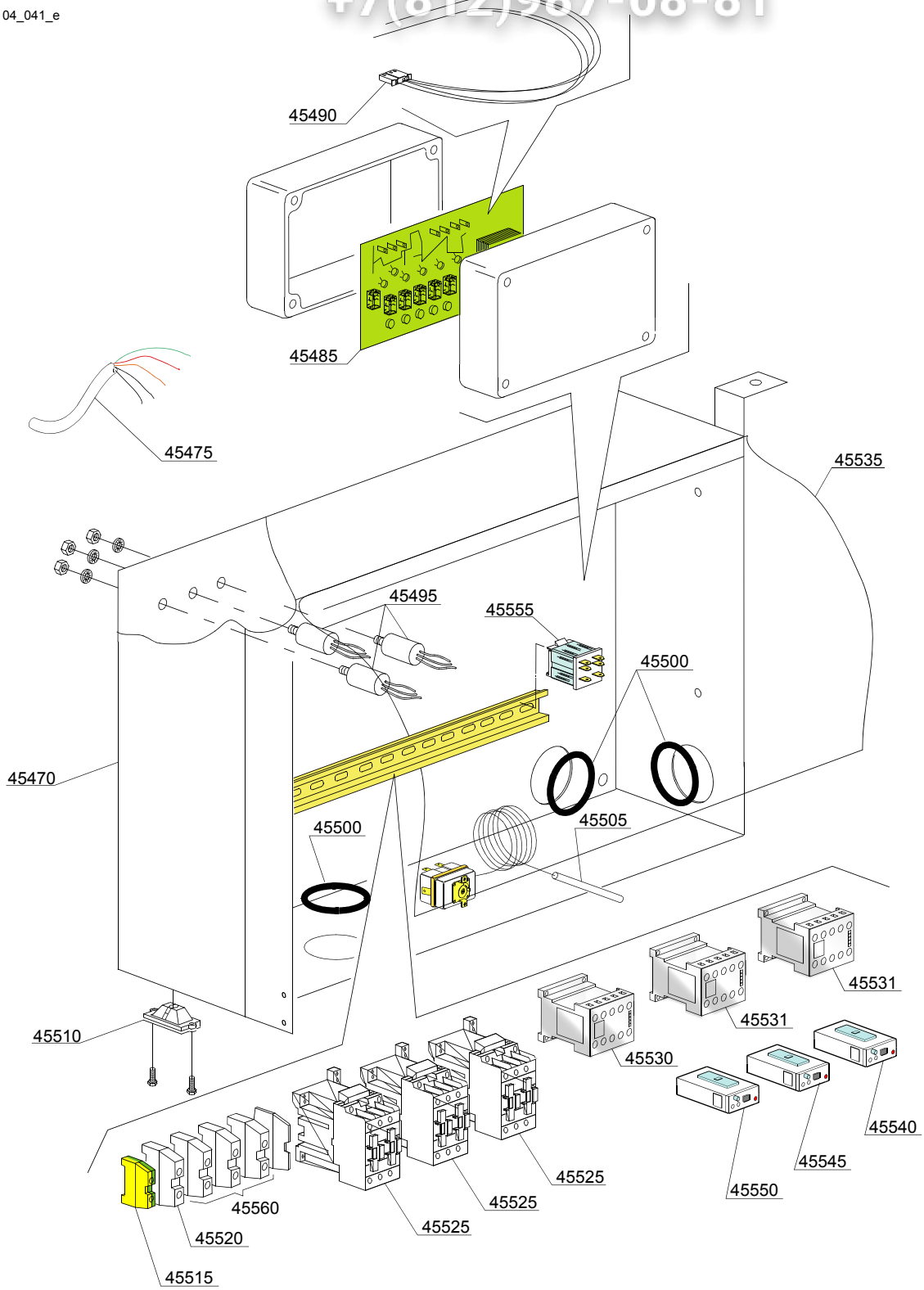

vsezip.ru

ID	P-code	SN from	SN to	Mod	Acces	Volt	Description
<b>Module: Electric control components</b>							
45470	91001		-	e			Electrical control panell
45475	80200		-	e		A,G	Power supply cable 5x4x3400
45475	75359		-	e		A,G	Power supply cable anti-flame 4x6x3400
45485	96710		-	e			Main board
45490	50562		-	e			DIHR ECO-2 Sensor
45495	15149		-	e		A,H,K,P	Filter F3 (0,33 mF)
45500	13324		-	e			Lead through rubber Ø46x50
45505	2000430		-	e			90/110 1500 PVC Safety Thermostat
45510	15065/A		-	e		A,H,K,P	Cable press with lives
45515	10300401		-	e			6/8mm <sup>2</sup> yellow/green terminal
45520	3006155		-	e			16mm <sup>2</sup> Neutral blue terminal
45525	10300050		-	e			Contactora 25A/12A 4NA 230V
45530	10300391		-	e			Contactora 230 V 3NA1NC 50-60Hz
45531	15086		-	e			Contactora 230 V
45535	11600039		-	e			Transparent protection for members electrical workes
45540	96203		-	e			0,2 - 0,24A temperature relay - RF9
45545	96202		-	e			0,9 - 1,5A temperature relay - RF9
45550	88113		-	e			6-10A temperature relay - RF9
45555	16037		-	e			16A bipolar relay 230V 50/60Hz
45560	3006082		-	e			16mm <sup>2</sup> SL-16 terminal

e=ELECTRONICAL SWITCHES, dc=DOUBLE BODY VERSION, uw=LOWER AND UPPER VERSION  
109E=109E

bp=BOOSTER PUMP, dd=DETERGENT DISPENCER

A=3/N/PE~380-400V 50-60Hz, D=3/PE~200-210V 50-60Hz, F=2/PE~220-240V 50-60Hz, G=3/N/PE~415V 50-60Hz,  
H=3/PE~220-230V 50-60Hz, K=3/PE~380-400V 50-60Hz, L=3/PE~415V 50-60Hz, M=3/PE~440V 60Hz, P=1/N/PE~220-  
230V 50-60Hz, R=2/PE~220-240V 50-60Hz, U=1/N/PE~240V 50-60Hz, V=3/PE~240V 50-60Hz, W=1/N/PE~100-110V  
50-60Hz

vsezip.ru

+7(812)987-08-81

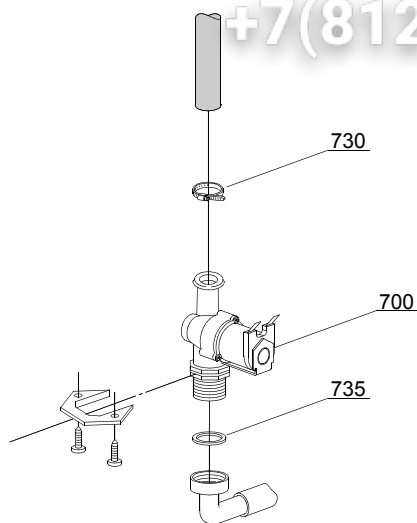

05\_002\_€

vsezip.ru

ID	P-code	SN from	SN to	Mod.	Acces.	Volt	Description
<b>Module:Solenoid valve group</b>							
700	10703		-	e,dc			Single solenoid valve - 230Vac
730	11807		-	e,dc			12/22 clamp (minimum 3 pieces)
735	13307		-	e,dc			3/4 gasket

e=ELECTRONICAL SWITCHES, dc=DOUBLE BODY VERSION, uw=LOWER AND UPPER VERSION

109E=109E

bp=BOOSTER PUMP, dd=DETERGENT DISPENCER

A=3/N/PE~380-400V 50-60Hz, D=3/PE~200-210V 50-60Hz, F=2/PE~220-240V 50-60Hz, G=3/N/PE~415V 50-60Hz, H=3/PE~220-230V 50-60Hz, K=3/PE~380-400V 50-60Hz, L=3/PE~415V 50-60Hz, M=3/PE~440V 60Hz, P=1/N/PE~220-230V 50-60Hz, R=2/PE~220-240V 50-60Hz, U=1/N/PE~240V 50-60Hz, V=3/PE~240V 50-60Hz, W=1/N/PE~100-110V 50-60Hz

06\_009ae

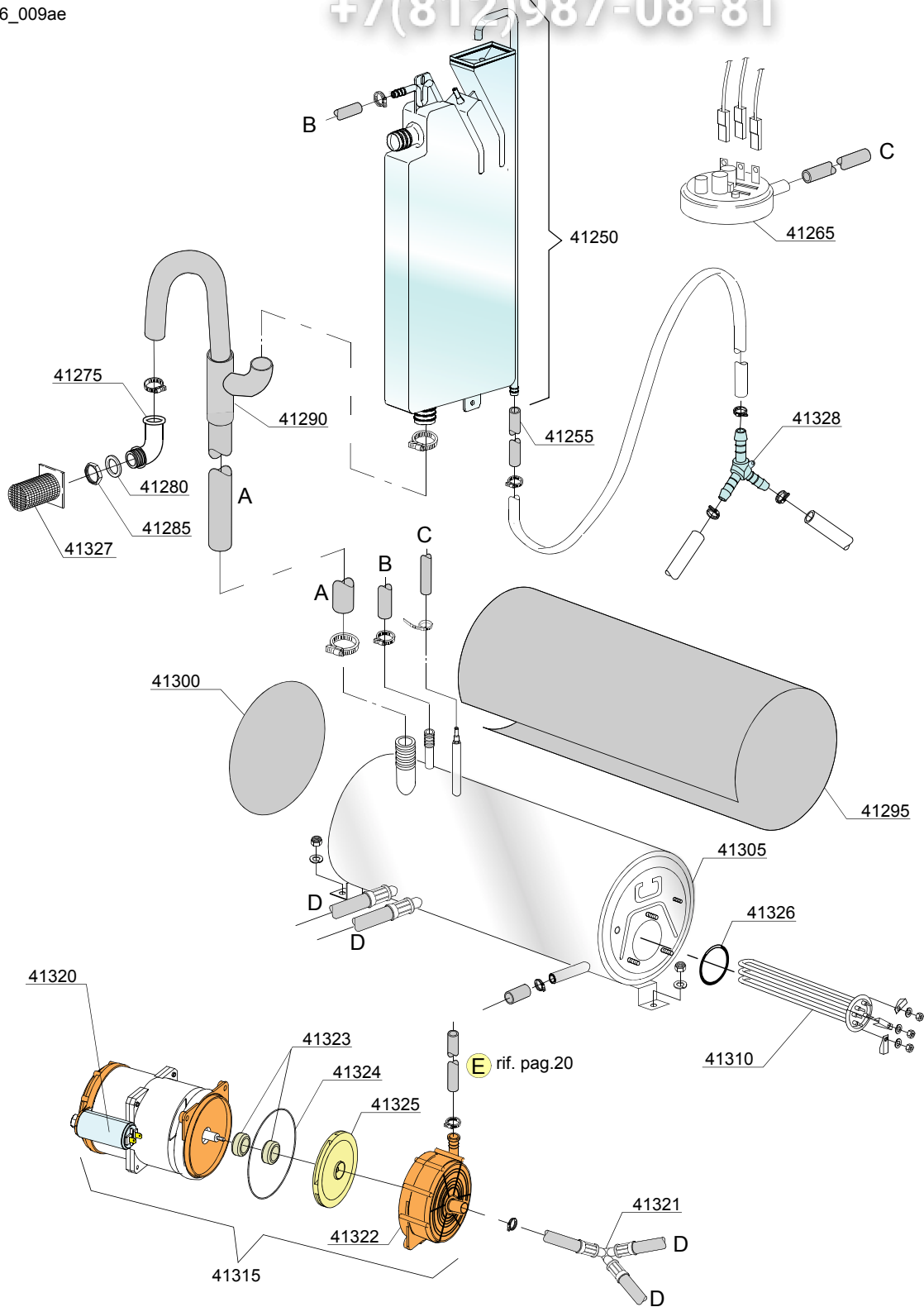

vsezip.ru

ID	P-code	SN from	SN to	Mod.	Acces	Volt	Description
<b>Module: Rinse with steady temperature</b>							
41250	15720		-	e,dc			Break tank assembly
41255	2907352		-	e,dc			PVC WRAS rubber hose
41265	10706/A		-	e,dc			47-27 pressure switch
41275	10701		-	e,dc			Drain elbow
41280	13305		-	e,dc			44x32x3 O-ring (minimum 5 pieces)
41285	11701/A		-	e,dc			Stainless steel nut
41290	91112		-	e,dc			Muff of emergency
41295	91116		-	e,dc			Insulation boiler 600x680
41300	91115		-	e,dc			Ø190x3 end piece
41305	91104		-	e,dc			Atmospheric Boiler AISI-316
41310	30001011		-	e,dc			Element 9,0 kW 230/240 VaC 3
41315	15100/DO		-	e,dc			Rinsing pump / booster pump 220/240V
41320	10702		-	e,dc			5 uF condenser
41321	91111		-	e,dc			Ø12 mm plastic 3 ways connection
41322	15100/V		-	e,dc			Scroll
41323	15100/S		-	e,dc			Rotating seals
41324	15100/T		-	e,dc			OR O-ring
41325	15100/U		-	e,dc			Pump rotor
41326	13015		-	e,dc			O-ring 6225 OR 160 NBR
41327	10914		-	e,dc			Filter nox
41328	540091		-	e,dc			Ø12 mm plastic 3 ways connection

e=ELECTRONICAL SWITCHES, dc=DOUBLE BODY VERSION, uw=LOWER AND UPPER VERSION  
109E=109E

bp=BOOSTER PUMP, dd=DETERGENT DISPENCER

A=3/N/PE~380-400V 50-60Hz, D=3/PE~200-210V 50-60Hz, F=2/PE~220-240V 50-60Hz, G=3/N/PE~415V 50-60Hz,  
H=3/PE~220-230V 50-60Hz, K=3/PE~380-400V 50-60Hz, L=3/PE~415V 50-60Hz, M=3/PE~440V 60Hz, P=1/N/PE~220-  
230V 50-60Hz, R=2/PE~220-240V 50-60Hz, U=1/N/PE~240V 50-60Hz, V=3/PE~240V 50-60Hz, W=1/N/PE~100-110V  
50-60Hz





ID	P-code	SN from	SN to	Mod.	Acces	Volt	Description
<b>Module: Rinse aid dispenser group</b>							
45155	10705/M		-	e,dc			Spring
45160	10705/N		-	e,dc			Disc to membrane
45165	10750/O		-	e,dc			Membrane
45175	12506		-	e,dc			Rubber-holder Ø 10mm
45180	10705/G		-	e,dc			Pipe fitting
45185	10705/C		-	e,dc			OR-gasket
45190	10705/D		-	e,dc			Silicone valve
45195	10705/C		-	e,dc			OR-gasket
45200	10705/T		-	e,dc			Sphere made of Teflon
45205	10705/R		-	e,dc			Brass pipe fitting
45210	10705/E		-	e,dc			OR-gasket Guide valve
45215	12525		-	e,dc			Ballast
45220	15058		-	e,dc			Small filter (minimum 3 pieces)
45225	10799/G		-	e,dc			GERMAC rinse aid dispenser
45232	11807		-	e,dc			Clamp 12-22 (minimum 3 pieces)
45233	540105		-	e,dc			Ø12-10-12 mm plastic 3 ways connection

e=ELECTRONICAL SWITCHES, dc=DOUBLE BODY VERSION, uw=LOWER AND UPPER VERSION

109E=109E

bp=BOOSTER PUMP, dd=DETERGENT DISPENSER

A=3/N/PE~380-400V 50-60Hz, D=3/PE~200-210V 50-60Hz, F=2/PE~220-240V 50-60Hz, G=3/N/PE~415V 50-60Hz, H=3/PE~220-230V 50-60Hz, K=3/PE~380-400V 50-60Hz, L=3/PE~415V 50-60Hz, M=3/PE~440V 60Hz, P=1/N/PE~220-230V 50-60Hz, R=2/PE~220-240V 50-60Hz, U=1/N/PE~240V 50-60Hz, V=3/PE~240V 50-60Hz, W=1/N/PE~100-110V 50-60Hz



ID	P-code	SN from	SN to	Mod.	Acces.	Volt	Description
<b>Module: Wash pump</b>							
45700	96013		-	uw			Group valves support
45705	96111		-	uw			Aspiration collector
45710	2902491		-	uw			60/80 clamp AISI-430 ( minimum 2 pieces )
45715	96107		-	uw			Stainless steel pipe 1"1/2
45720	96131		-	uw			York pipe Ø 60x100
45735	96108		-	uw			"UNIVERSAL" 2 ways stainless steel valve
45740	96110		-	uw			Valve connection clamp
45745	96112		-	uw			Anti-vibration M-F Ø 50 H=30
45750	96109		-	uw			2 points servo control assist + relay 50Hz
45750	96109/A		-	uw			2 points servo control assist + relay 60Hz
45755	96113		-	uw			Pump 3-kW 230/240 V 50Hz
45755	96113/A		-	uw			Pump 3-kW 230/400 V 60Hz
45755	96133/A		-	uw			Pump 3-kW 440 V 60Hz
45760	96106		-	uw			Stainless steel pipe 1"1/2
45770	96130		-	uw			York pipe Ø 50x100
45775	96114		-	uw			Stainless steel supply pipe
45780	11824		-	uw			50/70 clamp AISI-430 (minimum 2 pieces)

e=ELECTRONICAL SWITCHES, dc=DOUBLE BODY VERSION, uw=LOWER AND UPPER VERSION

109E=109E

bp=BOOSTER PUMP, dd=DETERGENT DISPENSER

A=3/N/PE~380-400V 50-60Hz, D=3/PE~200-210V 50-60Hz, F=2/PE~220-240V 50-60Hz, G=3/N/PE~415V 50-60Hz, H=3/PE~220-230V 50-60Hz, K=3/PE~380-400V 50-60Hz, L=3/PE~415V 50-60Hz, M=3/PE~440V 60Hz, P=1/N/PE~220-230V 50-60Hz, R=2/PE~220-240V 50-60Hz, U=1/N/PE~240V 50-60Hz, V=3/PE~240V 50-60Hz, W=1/N/PE~100-110V 50-60Hz

vsezip.ru

+7(812)987-08-81

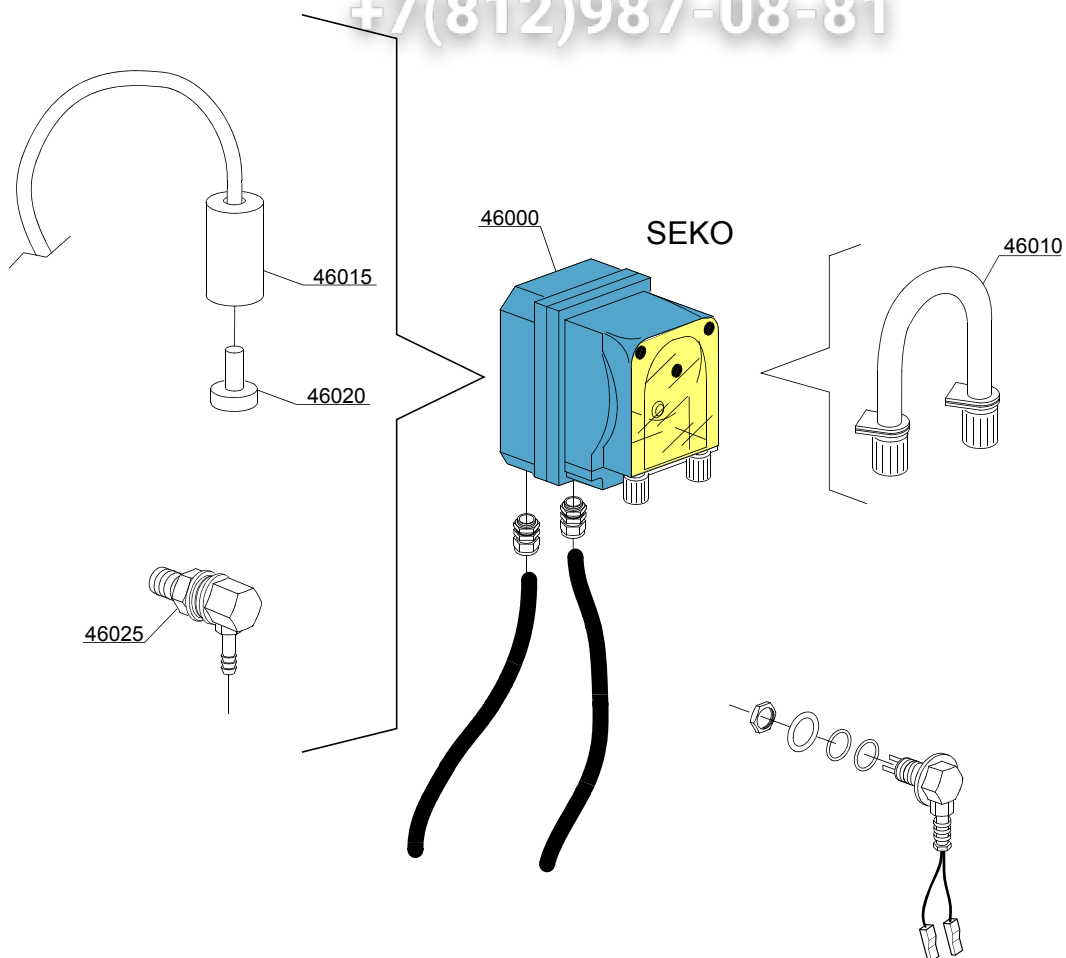

14\_004ae

vsezip.ru

ID	P-code	SN from	SN to	Mod.	Acces.	Volt	Description
<b>Module:Dosing detergent group</b>							
46000	15985/S		-		dd		Seko detergent pump
46010	15185		-		dd		Ø 10 Seko thermoplastic pipe
46015	12525		-		dd		Counter-weight
46020	15058		-		dd		Suction filter (minimum 3 pieces)
46025	15123		-		dd		Steel injector

e=ELECTRONICAL SWITCHES, dc=DOUBLE BODY VERSION, uw=LOWER AND UPPER VERSION

109E=109E

bp=BOOSTER PUMP, dd=DETERGENT DISPENSER

A=3/N/PE~380-400V 50-60Hz, D=3/PE~200-210V 50-60Hz, F=2/PE~220-240V 50-60Hz, G=3/N/PE~415V 50-60Hz, H=3/PE~220-230V 50-60Hz, K=3/PE~380-400V 50-60Hz, L=3/PE~415V 50-60Hz, M=3/PE~440V 60Hz, P=1/N/PE~220-230V 50-60Hz, R=2/PE~220-240V 50-60Hz, U=1/N/PE~240V 50-60Hz, V=3/PE~240V 50-60Hz, W=1/N/PE~100-110V 50-60Hz

vsezip.ru

+7(812)987-08-81

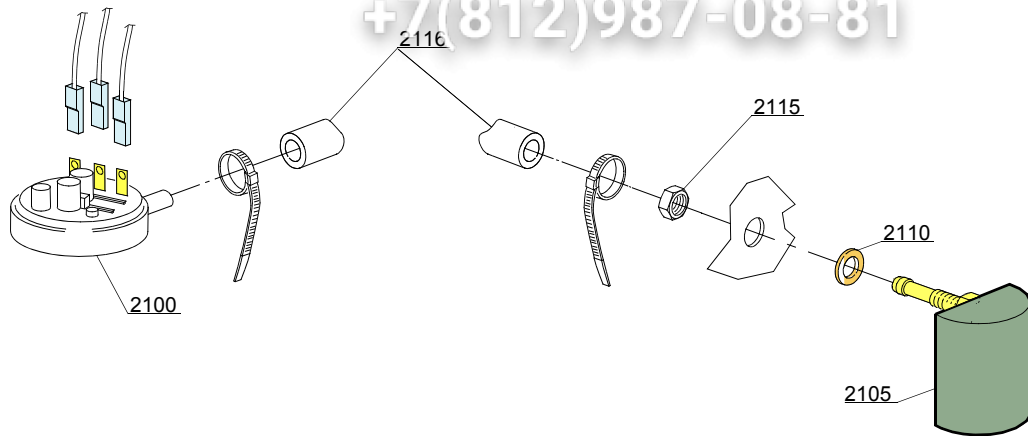

16\_001\_e

vsezip.ru

ID	P-code	SN from	SN to	Mod	Acces.	Volt	Description
<b>Module: Pressure switch group with air trap</b>							
2100	88110		-	dc			Pressure switch
2105	135911		-	dc			Air trap
2110	13301		-	dc			Gasket 14x8x1,5 (minimum 10 pieces)
2115	11702		-	dc			Nut M8 (minimum 10 pieces)
2116	14508		-	dc			Pressure tube EPDM 4,5x9

e=ELECTRONICAL SWITCHES, dc=DOUBLE BODY VERSION, uw=LOWER AND UPPER VERSION

109E=109E

bp=BOOSTER PUMP, dd=DETERGENT DISPENSER

A=3/N/PE~380-400V 50-60Hz, D=3/PE~200-210V 50-60Hz, F=2/PE~220-240V 50-60Hz, G=3/N/PE~415V 50-60Hz, H=3/PE~220-230V 50-60Hz, K=3/PE~380-400V 50-60Hz, L=3/PE~415V 50-60Hz, M=3/PE~440V 60Hz, P=1/N/PE~220-230V 50-60Hz, R=2/PE~220-240V 50-60Hz, U=1/N/PE~240V 50-60Hz, V=3/PE~240V 50-60Hz, W=1/N/PE~100-110V 50-60Hz

vsezip.ru

+7(812)987-08-81

17\_138\_e

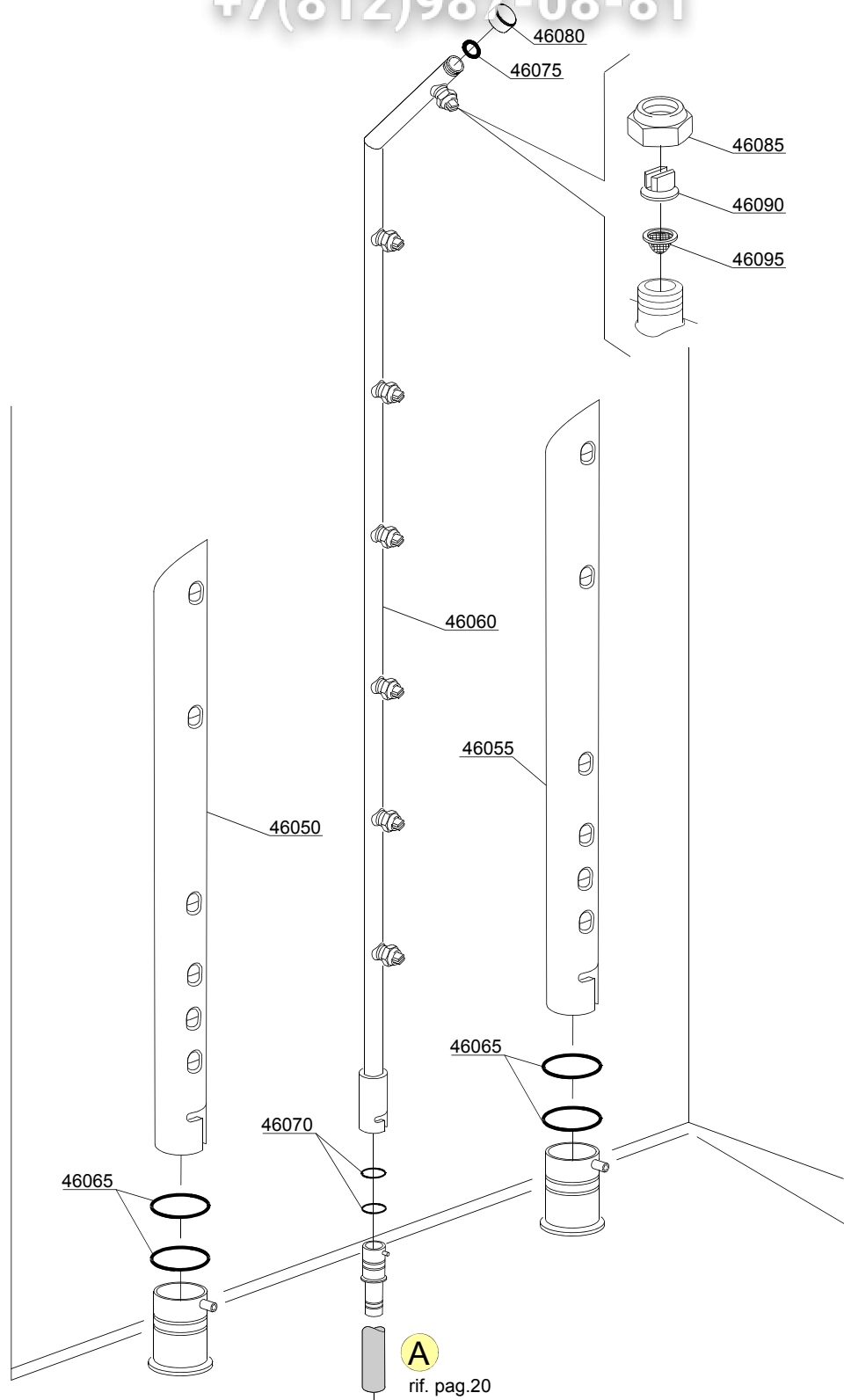



ID	P-code	SN from	SN to	Mod.	Acces	Volt	Description
<b>Module: Wash and rinse group</b>							
46050	96616		-	uw			Wash arm Type "A"
46055	96617		-	uw			Wash arm Type "B"
46060	96618		-	uw			Rinse arm
46065	96115		-	uw			OR gasket 3206 NBR 70
46070	13025		-	uw			OR gasket 2081
46075	2002051		-	uw			OR gasket EPDM Ø17x1,5
46080	2002054		-	uw			Inox plug M18x1 ( Ø 26x9 )
46085	2200116		-	uw			Stainless steel nut 3/8 F
46090	2200115		-	uw			Stainless steel rinse nozzle I-C1
46095	2200117		-	uw			Stainless steel rinse inox filtre

e=ELECTRONICAL SWITCHES, dc=DOUBLE BODY VERSION, uw=LOWER AND UPPER VERSION

109E=109E

bp=BOOSTER PUMP, dd=DETERGENT DISPENSER

A=3/N/PE~380-400V 50-60Hz, D=3/PE~200-210V 50-60Hz, F=2/PE~220-240V 50-60Hz, G=3/N/PE~415V 50-60Hz, H=3/PE~220-230V 50-60Hz, K=3/PE~380-400V 50-60Hz, L=3/PE~415V 50-60Hz, M=3/PE~440V 60Hz, P=1/N/PE~220-230V 50-60Hz, R=2/PE~220-240V 50-60Hz, U=1/N/PE~240V 50-60Hz, V=3/PE~240V 50-60Hz, W=1/N/PE~100-110V 50-60Hz

vsezip.ru

+7(812)987-08-81

23\_004\_e

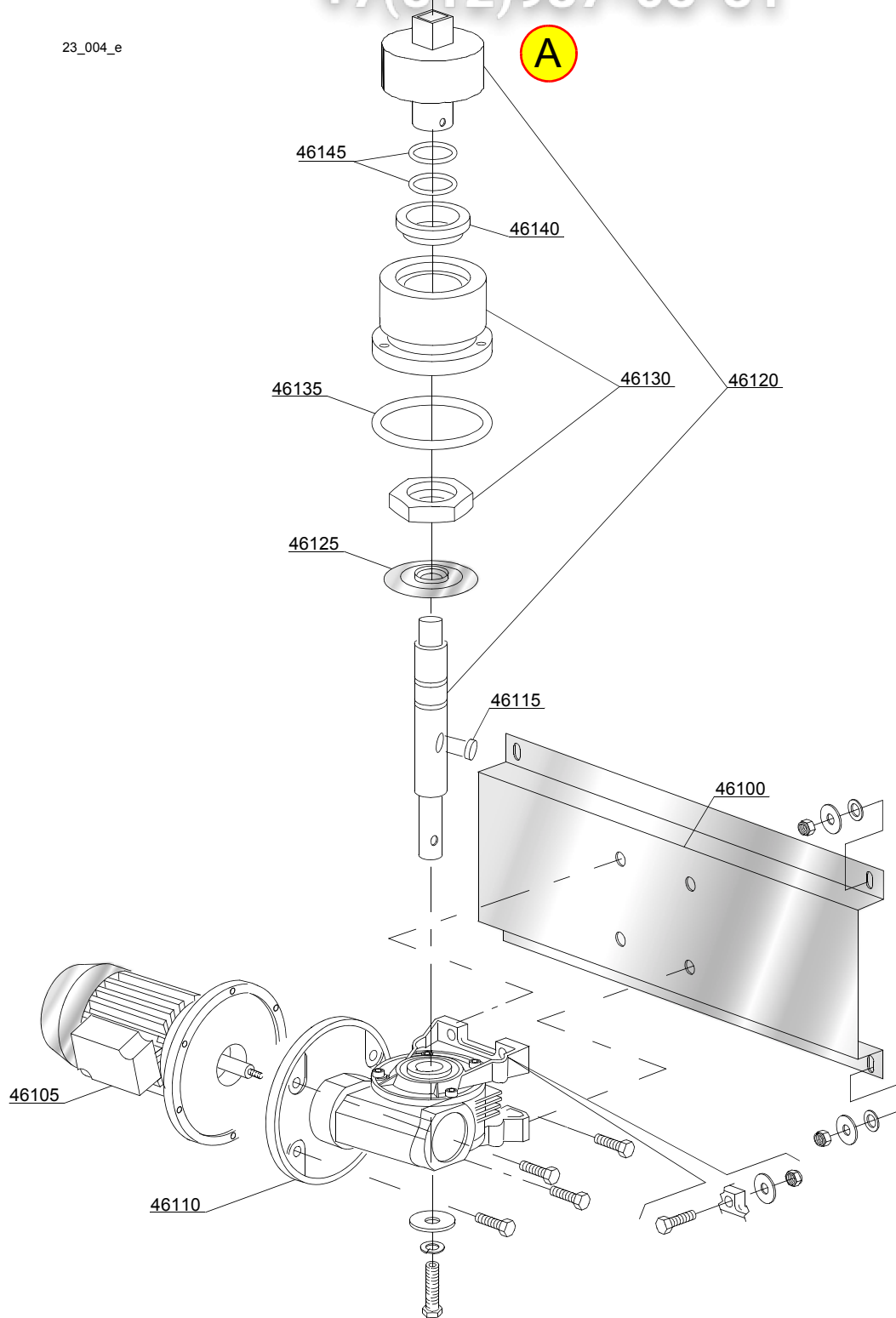

ID	P-code	SN from	SN to	Mod.	Acces.	Volt	Description
<b>Module: Motorgear components</b>							
46100	96010		-	uw			Motorgear support
46105	96128		-	uw			Conveyor motor - 12P 230 / 240 V 50 Hz 80W
46105	96128/A		-	uw			Conveyor motor - 12P 440 V 60 Hz 80W
46110	3000211		-	uw			Gear left 1:80
46115	2001046		-	uw			Inox key 8x7x30
46120	96122		-	uw			Crank shaft
46125	3004161		-	uw			Protection disk
46130	3004132		-	uw			Coupling part serie
46135	13015		-	uw			O-ring 6225 NBR-160
46140	13024		-	uw			Oil splash guard DEM 40 TC 30x42x7 with spring
46145	13023		-	uw			O-ring 131 ( 4093 )

e=ELECTRONICAL SWITCHES, dc=DOUBLE BODY VERSION, uw=LOWER AND UPPER VERSION

109E=109E

bp=BOOSTER PUMP, dd=DETERGENT DISPENCER

A=3/N/PE~380-400V 50-60Hz, D=3/PE~200-210V 50-60Hz, F=2/PE~220-240V 50-60Hz, G=3/N/PE~415V 50-60Hz, H=3/PE~220-230V 50-60Hz, K=3/PE~380-400V 50-60Hz, L=3/PE~415V 50-60Hz, M=3/PE~440V 60Hz, P=1/N/PE~220-230V 50-60Hz, R=2/PE~220-240V 50-60Hz, U=1/N/PE~240V 50-60Hz, V=3/PE~240V 50-60Hz, W=1/N/PE~100-110V 50-60Hz

23\_004ae

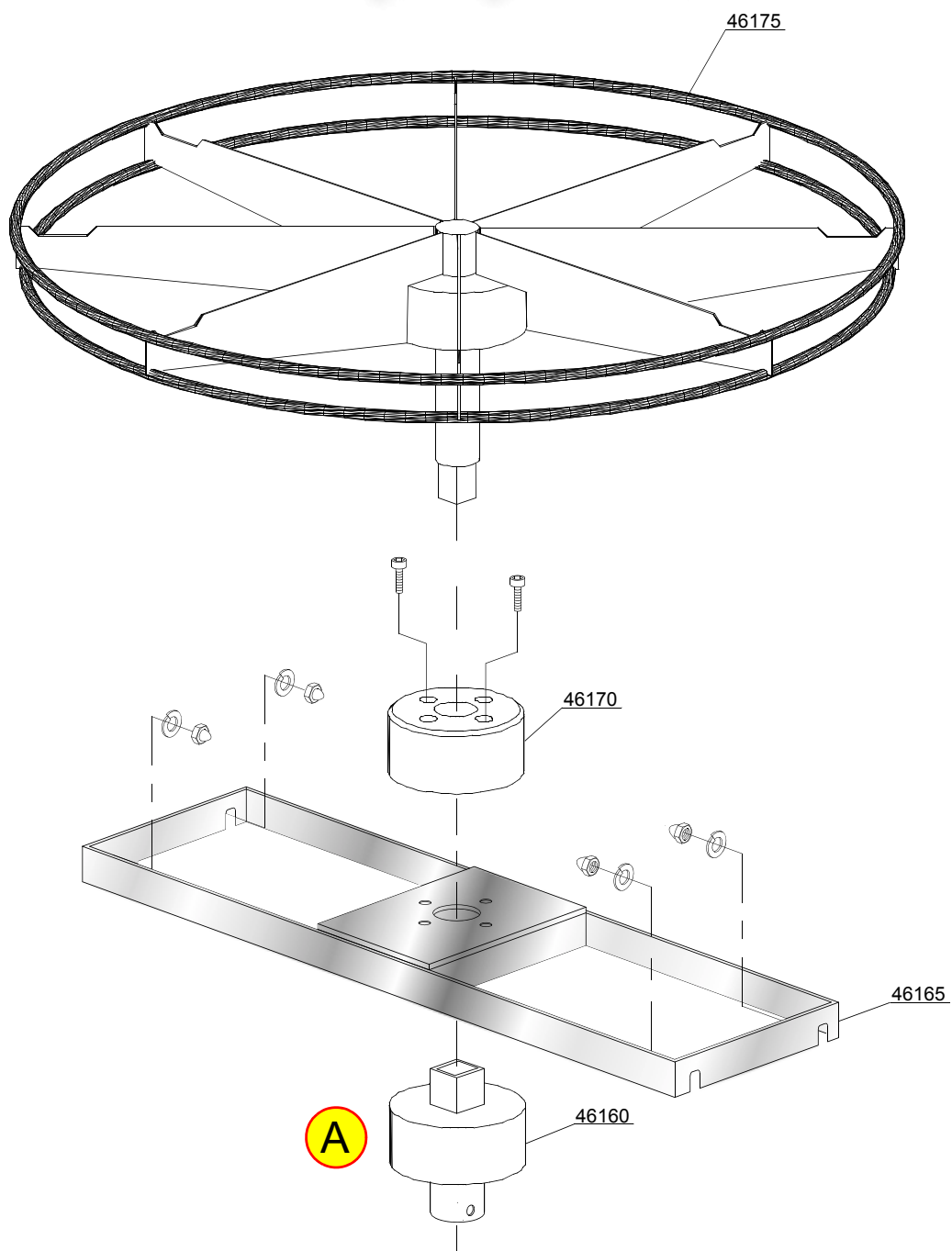

vsezip.ru

ID	P-code	SN from	SN to	Mod	Acces.	Volt	Description
<b>Module: Basket rotating system</b>							
46160	96122		-	uw			Basket axis
46165	96511		-	uw			Basket support chassis
46170	96123		-	uw			Coupling part serie
46175	96012		-	uw			Basket support

e=ELECTRONICAL SWITCHES, dc=DOUBLE BODY VERSION, uw=LOWER AND UPPER VERSION

109E=109E

bp=BOOSTER PUMP, dd=DETERGENT DISPENCER

A=3/N/PE~380-400V 50-60Hz, D=3/PE~200-210V 50-60Hz, F=2/PE~220-240V 50-60Hz, G=3/N/PE~415V 50-60Hz, H=3/PE~220-230V 50-60Hz, K=3/PE~380-400V 50-60Hz, L=3/PE~415V 50-60Hz, M=3/PE~440V 60Hz, P=1/N/PE~220-230V 50-60Hz, R=2/PE~220-240V 50-60Hz, U=1/N/PE~240V 50-60Hz, V=3/PE~240V 50-60Hz, W=1/N/PE~100-110V 50-60Hz

vsezip.ru

+7(812)987-08-81

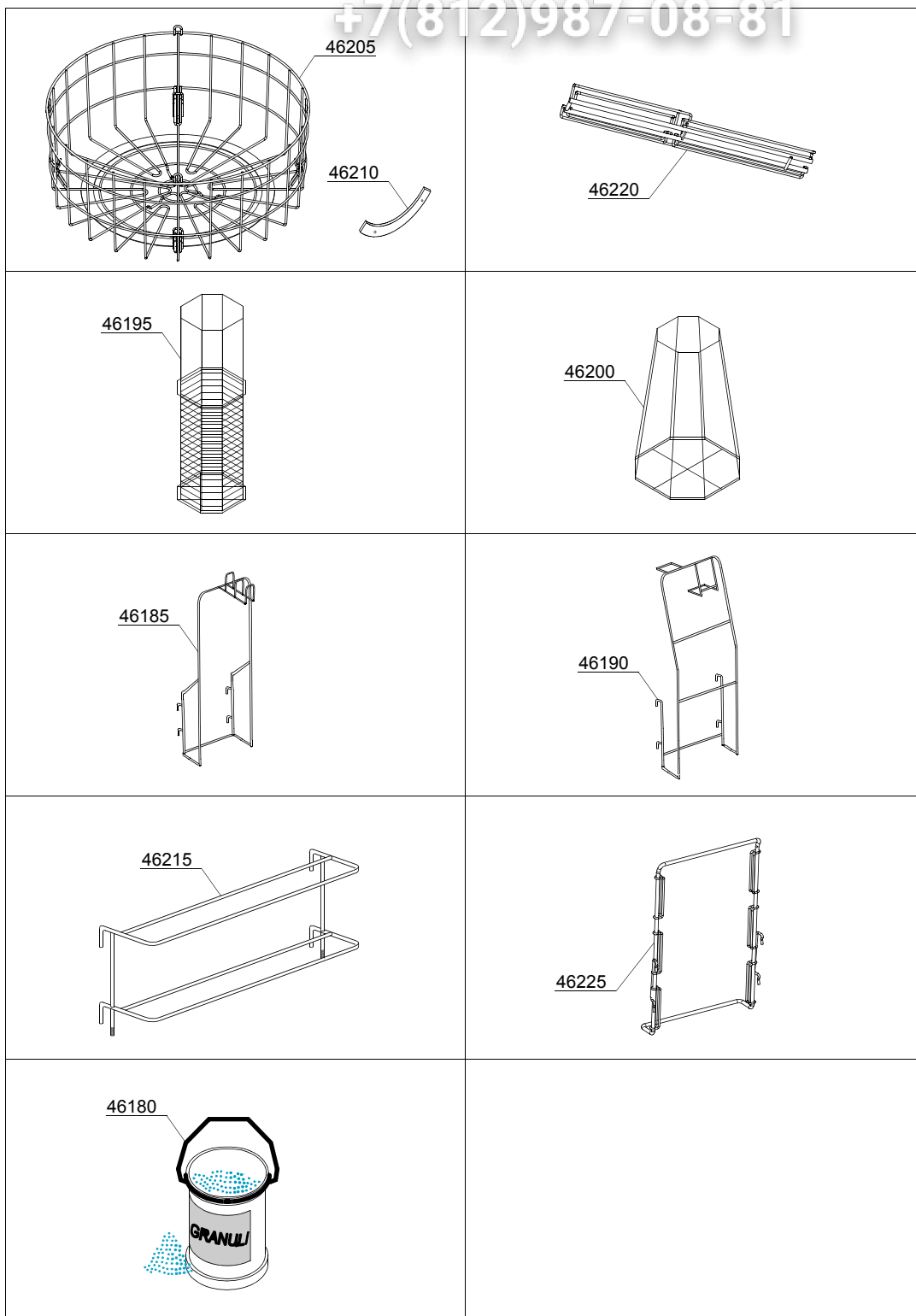

00\_005\_e

ID	P-code	SN from	SN to	Mod.	Acces	Volt	Description
<b>Module: Accessory</b>							
46180	96100		-	uw			Granules bucket ( 10 kg version )
46185	96105		-	uw			Holder for big pots
46190	96104		-	uw			Holder for small pots and frying pans
46195	96103		-	uw			Spatulas basket
46200	96102		-	uw			Spatulas basket support and pots holder
46205	96601		-	uw			Basket Ø 850mm H=350mm
46210	96125		-	uw			Basket skate ( 1/6 )
46215	96603			uw			800x400x400 Trays stand
46220	96602			uw			Support column
46225	96604			uw			Pan support 1/1 - 2/3 - 1/2 - 1/3

e=ELECTRONICAL SWITCHES, dc=DOUBLE BODY VERSION, uw=LOWER AND UPPER VERSION

109E=109E

bp=BOOSTER PUMP, dd=DETERGENT DISPENSER

A=3/N/PE~380-400V 50-60Hz, D=3/PE~200-210V 50-60Hz, F=2/PE~220-240V 50-60Hz, G=3/N/PE~415V 50-60Hz, H=3/PE~220-230V 50-60Hz, K=3/PE~380-400V 50-60Hz, L=3/PE~415V 50-60Hz, M=3/PE~440V 60Hz, P=1/N/PE~220-230V 50-60Hz, R=2/PE~220-240V 50-60Hz, U=1/N/PE~240V 50-60Hz, V=3/PE~240V 50-60Hz, W=1/N/PE~100-110V 50-60Hz