

Зип Общепит

vsezip.ru

+7(812)987-08-81

HOOD TYPE MACHINE

INSULATED HOOD
ELECTRONICAL CONTROL

TYPE: 110E

Accessories

BREAK TANK

BOOSTER PUMP

DVGW

WATER SOFTNER

DETERGENT DISPENSER

DRAIN PUMP

Spare parts manual

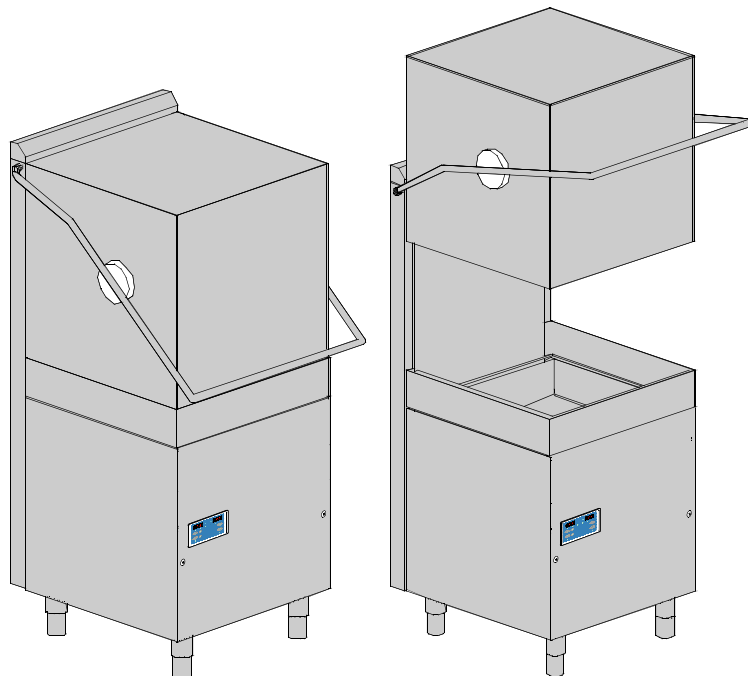

INFORMAZIONI GENERALI

Questo catalogo serve per richiedere con esattezza le parti di ricambio

Nelle ordinazioni indicare:

1) il numero dei codici dei particolari seguito dalla descrizione e la quantità desiderata;

2) Il codice alfa-numerico presente nella seconda colonna della tabella ;

I disegni delle parti di ricambio sono solo indicativi e non rappresentano il pezzo in oggetto.

I dati contenuti in questo catalogo sono indicativi e possono essere soggetti a modifiche senza impegno di preavviso.

ALLGEMEINE INFORMATIONEN

Dieser Ersatzteilkatalog dient zur genauen Angabe der Teile bei Ersatzteilbestellungen.

Bei Ersatzbestellung ist folgendes anzugeben:

1) Die Bestellnummer der Ersatzteile mit der entsprechenden Beschreibung genaue Menge;

2) Der alpha-numerischer Code auf der zweiten Reihe in dein Schuld;

Die Zeichnungen der Ersatzteile sind nur als Hinweise gedacht und stellen nicht das betroffene Teil dar.

Bei den im Katalog angeführten Daten handelt es sich um Anhaltsdaten, die jederzeit, ohne Vorankündigung, geändert werden können.

GENERAL INFORMATION

The present spare parts order exactly the right spare parts

When ordering specify:

1) the part's code number followed by its description and quantity needed;

2) The alpha-numeric code is in the second column in the chart;

Spare parts drawings are general and do not represent the part.

The contents of this catalogue are general and can undergo changes without prior notice.

INFORMACIONES GENERALES

El presente catálogo sirve para pedir con exactitud las partes de repuesto

En los pedidos se debe indicar:

1) el número de código de la parte y a continuación la descripción cantidad deseada;

2) El código alfanumerico presente en la segnada columna de la tabla;

Los diseños de las partes de recambio son solo indicativos y no representan la pieza en cuestión.

Los datos contenidos en el presente catálogo son indicativos y pueden modificarse sin aviso previo.

INFORMATIONS GENERALES

Ce catalogue permet de commander correctement les pièces détachées

Les commandes doivent être passées en indiquant:

1) le numero de code des pièces détachées suivi de leur description quantité désirée;

2) le code alphanumérique dans la deuxième colonne du tableau;

Les plans des pièces détachées sont fournis seulement à titre indicatif et ne représentent pas la pièce concernée.

Les données de ce catalogue sont citées seulement à titre indicatif et peuvent être l'objet de modifications sans avis préalable.

**ESEMPIO
EXAMPLE
EXEMPLE
BEISPIEL**

Rif.	Codici
MODULE:Particolari	
10505	540903
10510	540908
10515	15065/A
10520	540086
10525	540028



Note

Tutte le informazioni riportate si intendono aggiornate alla data di stampa. Il Produttore si riserva il diritto di apportare qualsiasi modifica richiesta dallo sviluppo evolutivo dei suddetti prodotti.

Per la sicurezza, la garanzia, l'affidabilità ed il valore della lavastoviglie usa solo ricambi originali. **Per alcuni codici, sono richieste quantità minime d'ordine.**



Attenzione

Questo libretto è parte integrante della lavastoviglie e, in caso di passaggio di proprietà, deve essere consegnato al nuovo acquirente.



Remarque

Toutes les informations contenues dans ce manuel s'entendent mises à jour à la date d'impression. En raison du développement constant de ses produits, usine se réserve le droit d'apporter à tout instant les modifications qu'elle jugera utiles.

Pour la sécurité, la garantie, la fiabilité et la valeur de votre lavevaisselles n'utilisez que des pièces de rechange d'origine. **Pour quelque référence on demande un minimum de pièces par commande**



Attention

Ce manuel doit être considéré comme partie intégrante de la lavevaisselles, en cas de transfert de propriété, doit toujours être remis au nouveau propriétaire.



Note

The information contained herein is valid at the time of going to print. The Company reserves the right to make any changes required by the future development of the above-mentioned products.

For your safety, as well as to preserve the warranty reliability and worth of your dishwashers, use original spare parts only. **For some codes a minimum quantity for order is required.**



Warning

This manual forms an integral part of the dishwashers and - if a transfer of title occurs - must always be handed over to the new owner.



Hinweis

Die Der Hersteller behält sich das Recht vor, jegliche, durch eine Weiterentwicklung der genannten Produkte bedingte Änderungen vornehmen zu können.

Verwenden Sie für Ihre Sicherheit, die Garantie, die Zuverlässigkeit und den Wert Ihrer machine originale Ersatzteile. **Für bestimmte Code nummer werden mindesten bestellungen verlangt.**



Achtung

Diese Betriebsanleitung ist Bestandteil des machine und muss bei seinem Weiterverkauf dem neuen Besitzer ausgehändigt werden.

vsezip.ru
+7(812)987-08-81

Code DW 999XXYYYY **CL/Part**

Model DESCRIPTION

S/N DW A 1015770 Type

400V 3N 50HZ 8A
3500W 500W

16A

IPX3

Pressione Dinamica alimentazione idrica 200-500 kPa
Pression dynamique arrivée d'eau
Dynamic pressure water supply
Dynamischer Druck asserreinlauf

Pressione dinamica vapore saturo
Pression dynamique vapore satueèè
Dymanischer Druck gesattigter Dampf
Pression Dinamica Vapor Saturado

TECHICAL SPECIFICATION

MADE IN ITALY

Temperatura massima acqua in ingresso 60°C
Temperature max eau a l'entre
Maximale Temperatur Wasseranschlü
Maximum Water temperature in-feeding

Model

S/N



Spare parts

Зип Общепит

vsezip.ru

+7(812)987-08-81

vsezip.ru

+7(812)987-08-81

1. Spare parts

General body parts.....	9
Closing panelig.....	11
Hood insulation.....	13
Control panel and switches.....	15
Electronic control HACCP	17
Electric control components	19
Solenoid valve group	21
Solenoid valve group	23
Break Tank	25
Booster pump.....	27
DVGW	29
Water softner group.....	31
Rinse aid dispenser group.....	33
Rinse aid dispenser group.....	35
Boiler group	37
3 ways connection	39

Wash pump group..... 41

Wash pump group..... 43

Dosing detergent group..... 45

Drain pump group..... 47

Pressure switch group with air trap ... 49

Turret group with rotating arms 51

Turret group with rotating arms 53

Turret group with rotating arms 57

1.1 Voltage codes

Volt	Voltage code
A	3/N/PE~380-400V 50-60Hz
D	3/PE~200-210V 50-60Hz
F	2/PE~220-240V 50-60Hz
G	3/N/PE~415V 50-60Hz
H	3/PE~220-230V 50-60Hz
K	3/PE~380-400V 50-60Hz
L	3/PE~415V 50-60Hz
M	3/PE~440V 60Hz
P	1/N/PE~220-230V 50-60Hz
R	2/PE~220-240V 50-60Hz
U	1/N/PE~240V 50-60Hz
V	3/PE~240V 50-60Hz
W	1/N/PE~100-110V 50-60Hz

1.2 Product codes

Product code	Full name
Model codes	
i	INSULATED HOOD
e	ELECTRONICAL CONTROL
Type codes	
110E	110E
Accessory codes	
bt	BREAK TANK
bp	BOOSTER PUMP
dvgw	DVGW
ws	WATER SOFTNER
dd	DETERGENT DISPENSER
dp	DRAIN PUMP

ID	P-code	SN from	SN to	Mod.	Acces.	Volt	Description
Module:General body parts							
42490	11600055		-				Right/left slide bearing
42495	11600001		-				Rack frame
42500	11600621		-				Left guide rail support
42505	13324		-				Cable screw cap
42510	15065/A		-				Cable-fastener with screw
42515	15116		-				Foot
42520	500606		-				Right side scrap tray
42525	150047		-				2,7/2,94KW 230/240V heating element
42530	76000		-				Frame assembly
42535	11600018		-				Basket support holder pin M6
42540	11600907		-				Strainer plate
42545	11600620		-				Right guide rail support
42555	70305		-				Hood switch
42560	11600630		-				Back panel
42565	10600923		-				Guide rail
42570	500615		-				Ferrule with filter
42575	500616		-				Suction filter
42580	13021		-				DEM 40 O-ring
42585	500619		-				Overflow pipe
42590	80208		-				95x75x3 O-ring
42595	76007		-				Sleeper holder-filter
42596	500600		-				Interior filter with rack
42597	500607		-				Ferrule with filter
42598	10700		-				Spring
42599	11600059		-				Support for the security system assembly
42600	76252		-				Security system cord
42601	11600058		-				Passage ring for the security cord

i=INSULATED HOOD, e=ELECTRONICAL CONTROL

110E=110E

bt=BREAK TANK, bp=BOOSTER PUMP, dvgw=DVGW, ws=WATER SOFTNER, dd=DETERGENT DISPENSER, dp=DRAIN PUMP

A=3/N/PE~380-400V 50-60Hz, D=3/PE~200-210V 50-60Hz, F=2/PE~220-240V 50-60Hz, G=3/N/PE~415V 50-60Hz, H=3/PE~220-230V 50-60Hz, K=3/PE~380-400V 50-60Hz, L=3/PE~415V 50-60Hz, M=3/PE~440V 60Hz, P=1/N/PE~220-230V 50-60Hz, R=2/PE~220-240V 50-60Hz, U=1/N/PE~240V 50-60Hz, V=3/PE~240V 50-60Hz, W=1/N/PE~100-110V 50-60Hz

vsezip.ru

+7(812)987-08-81

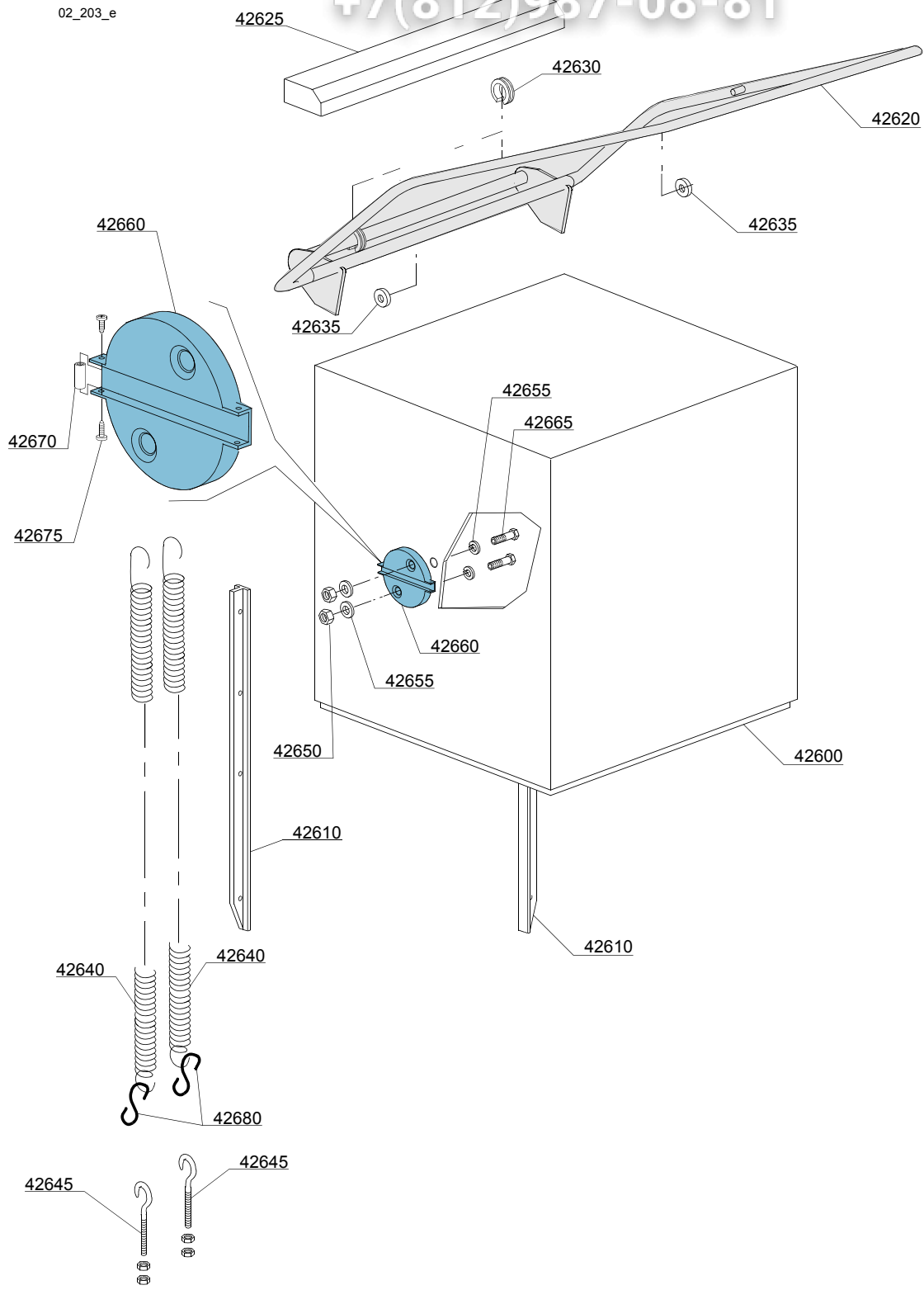

vsezip.ru

ID	P-code	SN from	SN to	Mod.	Acces.	Volt	Description
Module: Closing panelig							
42600	76001		-				Hood, complete
42610	76080		-				Guide
42620	76075		-				Handle
42625	11600913		-				Spoiler
42630	70306		-				Spring hook joint
42635	89919		-				Bearing
42640	75303		-				Hood spring
42645	10800210		-				Hook screw
42650	11718		-				M8 stainless steel self-locking nut
42655	13301		-				Gasket 14x8x1,5
42660	11600036		-				Bearing holder (grey)
42665	11216		-				Inox screw M8x20 TE
42670	76251		-				Spacer
42675	11121		-				M4x10 TCB Inox screw
42680	76253		-				"S"Hook D6x65

i=INSULATED HOOD, e=ELECTRONICAL CONTROL

110E=110E

bt=BREAK TANK, bp=BOOSTER PUMP, dvgw=DVGW, ws=WATER SOFTNER, dd=DETERGENT DISPENSER, dp=DRAIN PUMP

A=3/N/PE~380-400V 50-60Hz, D=3/PE~200-210V 50-60Hz, F=2/PE~220-240V 50-60Hz, G=3/N/PE~415V 50-60Hz, H=3/PE~220-230V 50-60Hz, K=3/PE~380-400V 50-60Hz, L=3/PE~415V 50-60Hz, M=3/PE~440V 60Hz, P=1/N/PE~220-230V 50-60Hz, R=2/PE~220-240V 50-60Hz, U=1/N/PE~240V 50-60Hz, V=3/PE~240V 50-60Hz, W=1/N/PE~100-110V 50-60Hz

vsezip.ru

+7(812)987-08-81

02_202_e

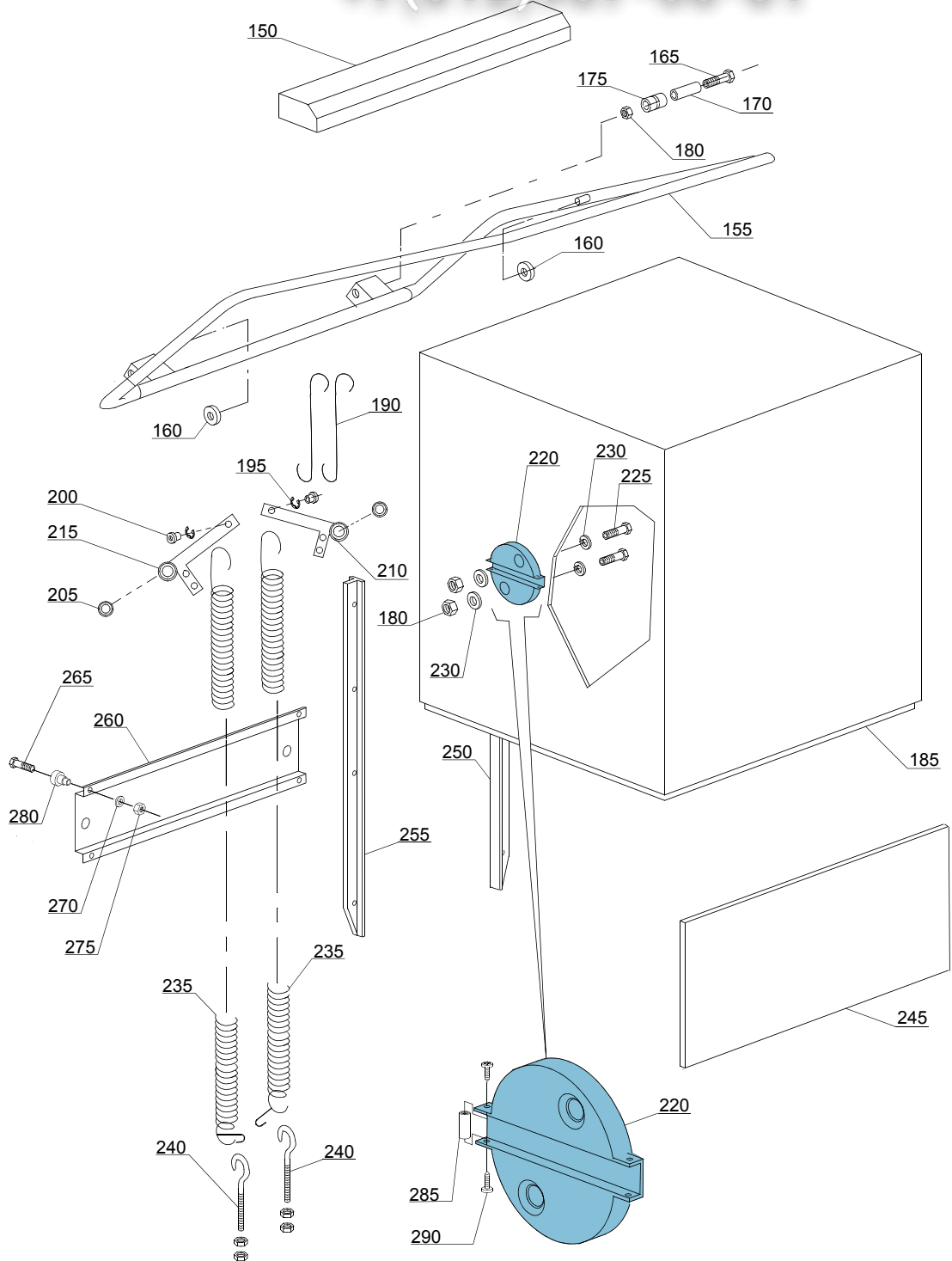

ID	P-code	SN from	SN to	Mod.	Acces.	Volt	Description
Module:Hood insulation							
150	11600913		-				Guide
155	11600910		-				Handle
160	89919		-				Bearing
165	11214		-				Screw
170	11600015		-				Filter
175	11600014		-				Roller
180	11718		-				M8 stainless steel self-locking nut
185	11600902		-				Hood, complete
190	11600013		-				Hook
195	11823		-				Ø10 stainless steel snap ring
200	11600038		-				Spring bush
205	10800010		-				Bearing
210	11600026		-				Elbow, right
215	11600027		-				Elbow, left
220	11600030		-				Bearing holder
225	11110		-				Screw
230	13301		-				Gasket
235	70302		-				Hood spring
240	10800210		-				Hook screw
250	11600028		-				Guide, right
255	11600029		-				Guide, left
260	11600624		-				Leavers bearing for hood
265	11134		-				M10x35 TE Stainless steel screw
270	11192		-				M10 Stainless steel spring washer
275	11719		-				M10 inox nut
280	10800115		-				Lifting rod pin
285	76251		-				Spacer
290	11121		-				M4x10 TCB Inox screw

i=INSULATED HOOD, e=ELECTRONICAL CONTROL

110E=110E

bt=BREAK TANK, bp=BOOSTER PUMP, dvgw=DVGW, ws=WATER SOFTNER, dd=DETERGENT DISPENSER, dp=DRAIN PUMP

A=3/N/PE~380-400V 50-60Hz, D=3/PE~200-210V 50-60Hz, F=2/PE~220-240V 50-60Hz, G=3/N/PE~415V 50-60Hz, H=3/PE~220-230V 50-60Hz, K=3/PE~380-400V 50-60Hz, L=3/PE~415V 50-60Hz, M=3/PE~440V 60Hz, P=1/N/PE~220-230V 50-60Hz, R=2/PE~220-240V 50-60Hz, U=1/N/PE~240V 50-60Hz, V=3/PE~240V 50-60Hz, W=1/N/PE~100-110V 50-60Hz

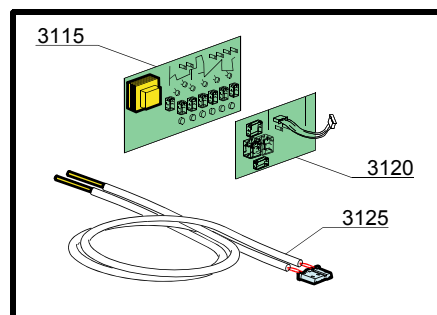
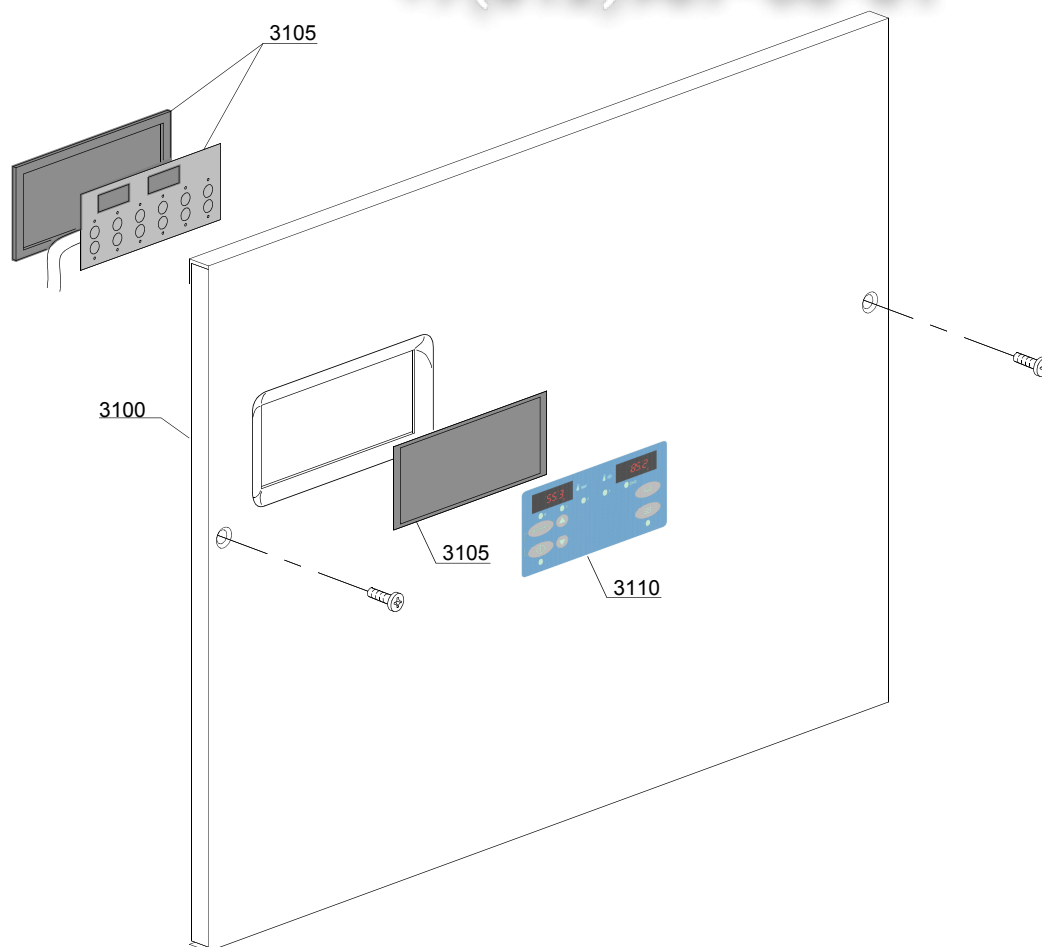

ID	P-code	SN from	SN to	Mod.	Acces.	Volt	Description
Module:Control panel and switches							
3100	11600959		-				Control panel
3105	50570		-				Compleat membrane push button-driver
3110	50599		-		dp,ws		Silkscreen processed grill membrane push button-driver dp+ws [F]
3110	50575		-		dp,ws		Neutral silkscreen processed grill membrane push button-driver dp+ws [N]
3110	50578		-		dp,ws		Silkscreen processed grill membrane push button-driver dp+ws [K]
3115	50569		-				Electronic card without chip
3120	50559		-		dp		Circuit board Exp-Ps
3120	50568		-		ws		Circuit board Exp-Dep
3125	50562		-				Sensor

i=INSULATED HOOD, e=ELECTRONICAL CONTROL

110E=110E

bt=BREAK TANK, bp=BOOSTER PUMP, dvgw=DVGW, ws=WATER SOFTNER, dd=DETERGENT DISPENSER, dp=DRAIN PUMP

A=3/N/PE~380-400V 50-60Hz, D=3/PE~200-210V 50-60Hz, F=2/PE~220-240V 50-60Hz, G=3/N/PE~415V 50-60Hz, H=3/PE~220-230V 50-60Hz, K=3/PE~380-400V 50-60Hz, L=3/PE~415V 50-60Hz, M=3/PE~440V 60Hz, P=1/N/PE~220-230V 50-60Hz, R=2/PE~220-240V 50-60Hz, U=1/N/PE~240V 50-60Hz, V=3/PE~240V 50-60Hz, W=1/N/PE~100-110V 50-60Hz

vsezip.ru

+7(812)987-08-81

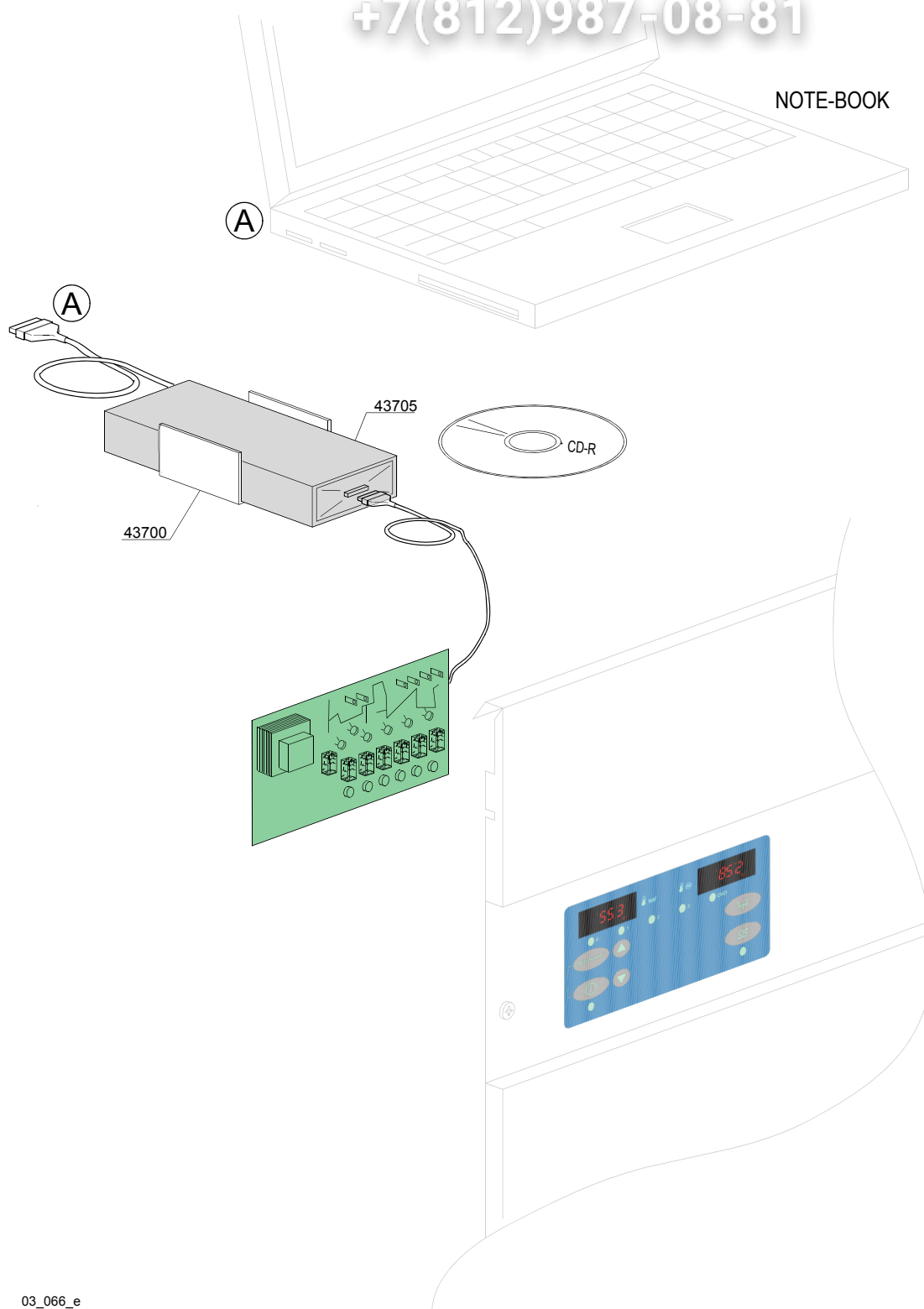

03_066_e

vsezip.ru

ID	P-code	SN from	SN to	Mod.	Acces.	Volt	Description
Module:Electronic control HACCP							
43700	3060200		-	e			Support DATA-LOGGER
43705	99910217		-	e			Kit remote control HACCP

i=INSULATED HOOD, e=ELECTRONICAL CONTROL

110E=110E

bt=BREAK TANK, bp=BOOSTER PUMP, dvgw=DVGW, ws=WATER SOFTNER, dd=DETERGENT DISPENSER, dp=DRAIN PUMP

A=3/N/PE~380-400V 50-60Hz, D=3/PE~200-210V 50-60Hz, F=2/PE~220-240V 50-60Hz, G=3/N/PE~415V 50-60Hz, H=3/PE~220-230V 50-60Hz, K=3/PE~380-400V 50-60Hz, L=3/PE~415V 50-60Hz, M=3/PE~440V 60Hz, P=1/N/PE~220-230V 50-60Hz, R=2/PE~220-240V 50-60Hz, U=1/N/PE~240V 50-60Hz, V=3/PE~240V 50-60Hz, W=1/N/PE~100-110V 50-60Hz

vsezip.ru

+7(812)987-08-81

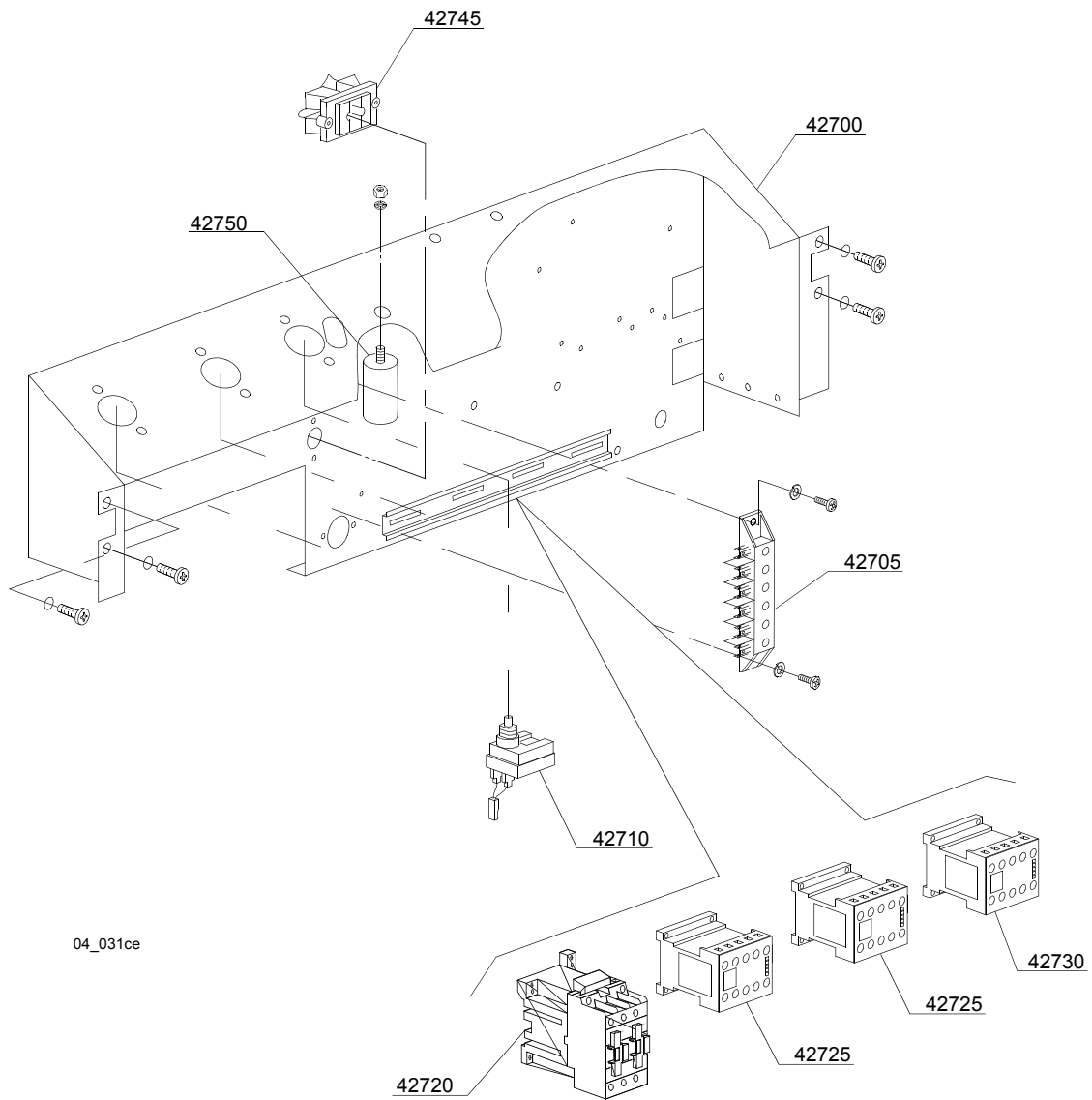
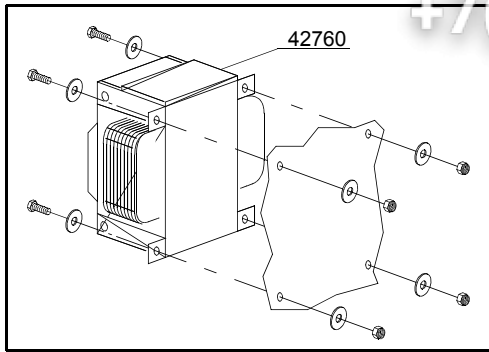

ID	P-code	SN from	SN to	Mod	Acces.	Volt	Description
Module: Electric control components							
42700	76002		-				Electric component panel
42705	500551		-				6 poles terminal board
42710	2000430		-				Safety thermostat
42720	10300050		-				25A/12A contactor - 230V 50/60HZ
42720	10300052		-				36A/20A contactor - 230V 50/60HZ
42720	10300054		-				25A/16A contactor - 230V 50/60HZ
42725	15086		-				Contactor 230V 50/60Hz 4C
42725	15086/B		-				Contactor 240V 50Hz
42730	10300391		-				3NA/1NC contactor 230V 50/60HZ
42730	10300392		-				3NA/1NC contactor - 240Vac 50Hz
42745	15065/A		-				Cable-fastener with screw
42750	15149		-				Low noise filter
42760	15381		-				0-230 160/230/400/415/440 VA Transformer

i=INSULATED HOOD, e=ELECTRONICAL CONTROL

110E=110E

bt=BREAK TANK, bp=BOOSTER PUMP, dvgw=DVGW, ws=WATER SOFTNER, dd=DETERGENT DISPENSER, dp=DRAIN PUMP

A=3/N/PE~380-400V 50-60Hz, D=3/PE~200-210V 50-60Hz, F=2/PE~220-240V 50-60Hz, G=3/N/PE~415V 50-60Hz, H=3/PE~220-230V 50-60Hz, K=3/PE~380-400V 50-60Hz, L=3/PE~415V 50-60Hz, M=3/PE~440V 60Hz, P=1/N/PE~220-230V 50-60Hz, R=2/PE~220-240V 50-60Hz, U=1/N/PE~240V 50-60Hz, V=3/PE~240V 50-60Hz, W=1/N/PE~100-110V 50-60Hz

vsezip.ru

+7(812)987-08-81

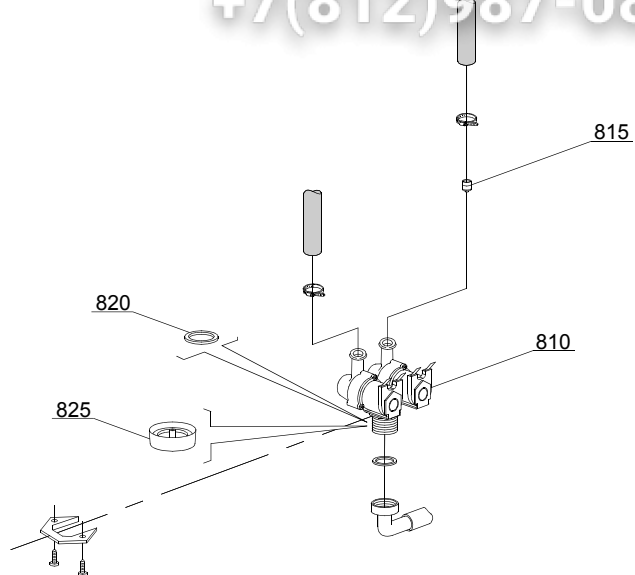

05_003_e

vsezip.ru

ID	P-code	SN from	SN to	Mod.	Acces.	Volt	Description
Module:Solenoid valve group							
810	15098		-	i	ws		Double solenoid valve - Ø10
815	15115		-	i	ws		Green pression solenoid valve
820	N.C.		-	i	ws		Pression reducing valve

i=INSULATED HOOD, e=ELECTRONICAL CONTROL

110E=110E

bt=BREAK TANK, bp=BOOSTER PUMP, dvgw=DVGW, ws=WATER SOFTNER, dd=DETERGENT DISPENSER, dp=DRAIN PUMP

A=3/N/PE~380-400V 50-60Hz, D=3/PE~200-210V 50-60Hz, F=2/PE~220-240V 50-60Hz, G=3/N/PE~415V 50-60Hz, H=3/PE~220-230V 50-60Hz, K=3/PE~380-400V 50-60Hz, L=3/PE~415V 50-60Hz, M=3/PE~440V 60Hz, P=1/N/PE~220-230V 50-60Hz, R=2/PE~220-240V 50-60Hz, U=1/N/PE~240V 50-60Hz, V=3/PE~240V 50-60Hz, W=1/N/PE~100-110V 50-60Hz

vsezip.ru

+7(812)987-08-81

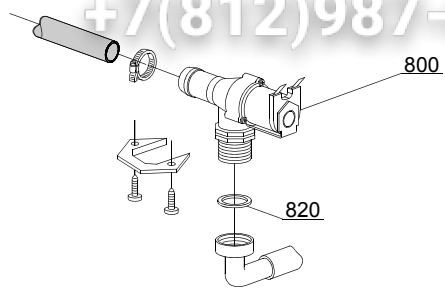

05_005_e

ID	P-code	SN from	SN to	Mod	Acces.	Volt	Description
Module:Solenoid valve group							
800	30001000		-	i			Solenoid valve
820	N.C.		-	i			Pression reducing valve

i=INSULATED HOOD, e=ELECTRONICAL CONTROL

110E=110E

bt=BREAK TANK, bp=BOOSTER PUMP, dvgw=DVGW, ws=WATER SOFTNER, dd=DETERGENT DISPENSER, dp=DRAIN PUMP

A=3/N/PE~380-400V 50-60Hz, D=3/PE~200-210V 50-60Hz, F=2/PE~220-240V 50-60Hz, G=3/N/PE~415V 50-60Hz, H=3/PE~220-230V 50-60Hz, K=3/PE~380-400V 50-60Hz, L=3/PE~415V 50-60Hz, M=3/PE~440V 60Hz, P=1/N/PE~220-230V 50-60Hz, R=2/PE~220-240V 50-60Hz, U=1/N/PE~240V 50-60Hz, V=3/PE~240V 50-60Hz, W=1/N/PE~100-110V 50-60Hz

vsezip.ru

+7(812)987-08-81

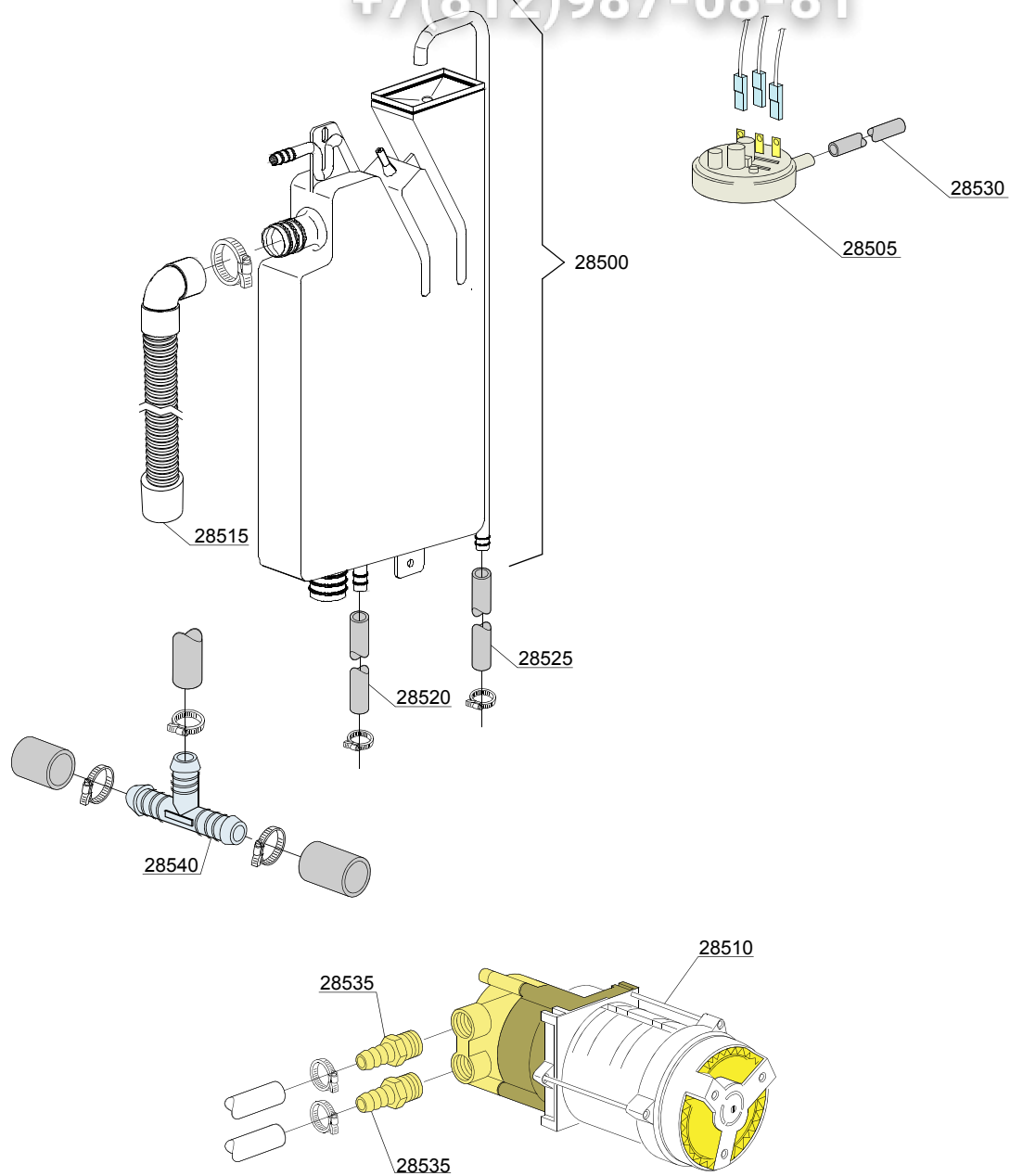

06_004pe

ID	P-code	SN from	SN to	Mod	Acces.	Volt	Description
Module:Break Tank							
28505	10706/A		-	e,i	bt		47-27 pressure switch
28510	15100/D		-	e,i	bt		Booster pump 220/240V - body pumps in brass
28515	15722		-	e,i	bt		BT middle pipe L=920
28520	2907350		-	e,i	bt		12x20 EPDM rubber hose
28525	2907352		-	e,i	bt		PVC WRAS rubber hose
28530	14508		-	e,i	bt		4,5x9 EPDM rubber hose (minimum 2 mt)
28535	10221311		-	e,i	bt		Rubber holder Ø 12 3/8G
28540	540098			e,i	bt		3 ways D25

i=INSULATED HOOD, e=ELECTRONICAL CONTROL

110E=110E

bt=BREAK TANK, bp=BOOSTER PUMP, dvgw=DVGW, ws=WATER SOFTNER, dd=DETERGENT DISPENSER, dp=DRAIN PUMP

A=3/N/PE~380-400V 50-60Hz, D=3/PE~200-210V 50-60Hz, F=2/PE~220-240V 50-60Hz, G=3/N/PE~415V 50-60Hz, H=3/PE~220-230V 50-60Hz, K=3/PE~380-400V 50-60Hz, L=3/PE~415V 50-60Hz, M=3/PE~440V 60Hz, P=1/N/PE~220-230V 50-60Hz, R=2/PE~220-240V 50-60Hz, U=1/N/PE~240V 50-60Hz, V=3/PE~240V 50-60Hz, W=1/N/PE~100-110V 50-60Hz

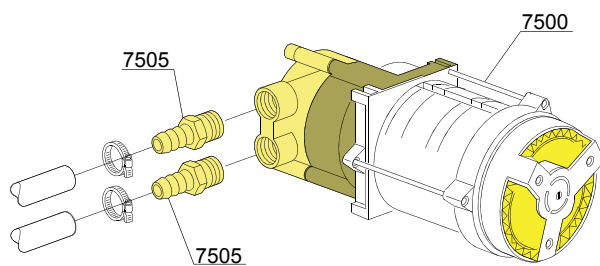

VERSIONE STANDARD / VERSIONE POMPA AUM. PRESSIONE
STANDARD VERSION / BOOSTER PUMP VERSION
VERSION STANDARD / VERSION POMPE AUGMENT. PRESSION

vsezip.ru

ID	P-code	SN from	SN to	Mod.	Acces.	Volt	Description
Module:Booster pump							
7500	15100/D		-	e,i,i	bp		Booster pump 220/240V - body pumps in brass
7505	10221311		-	e,i,i	bp		Rubber holder Ø 12 3/8G

i=INSULATED HOOD, e=ELECTRONICAL CONTROL

110E=110E

bt=BREAK TANK, bp=BOOSTER PUMP, dvgw=DVGW, ws=WATER SOFTNER, dd=DETERGENT DISPENSER, dp=DRAIN PUMP

A=3/N/PE~380-400V 50-60Hz, D=3/PE~200-210V 50-60Hz, F=2/PE~220-240V 50-60Hz, G=3/N/PE~415V 50-60Hz, H=3/PE~220-230V 50-60Hz, K=3/PE~380-400V 50-60Hz, L=3/PE~415V 50-60Hz, M=3/PE~440V 60Hz, P=1/N/PE~220-230V 50-60Hz, R=2/PE~220-240V 50-60Hz, U=1/N/PE~240V 50-60Hz, V=3/PE~240V 50-60Hz, W=1/N/PE~100-110V 50-60Hz

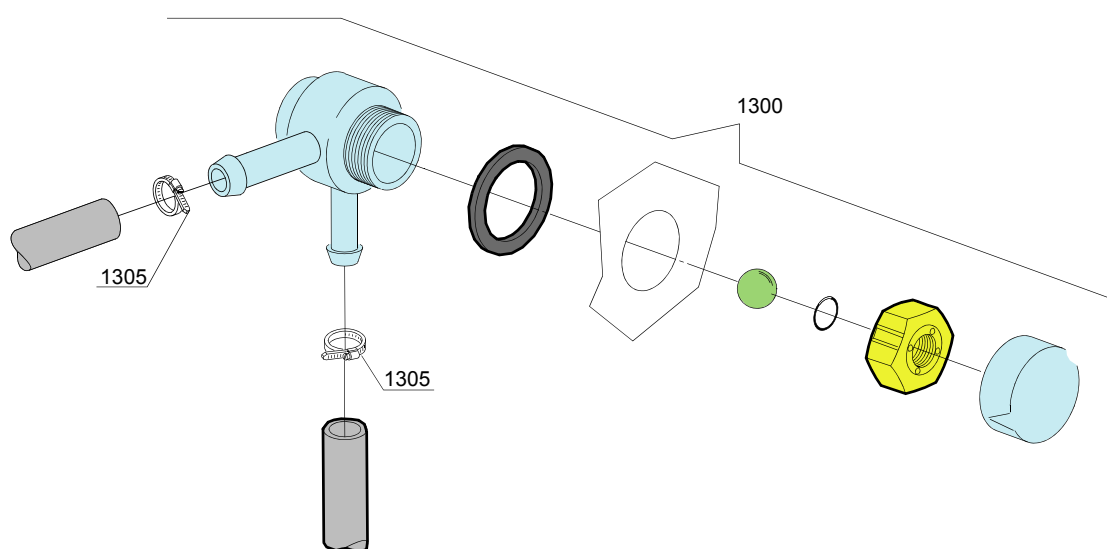

vsezip.ru

ID	P-code	SN from	SN to	Mod	Acces.	Volt	Description
Module: DVGW							
1300	9814351		-		dvgw		DVGW assembly
1305	11807		-		dvgw		Clamp 12/22

i=INSULATED HOOD, e=ELECTRONICAL CONTROL

110E=110E

bt=BREAK TANK, bp=BOOSTER PUMP, dvgw=DVGW, ws=WATER SOFTNER, dd=DETERGENT DISPENSER, dp=DRAIN PUMP

A=3/N/PE~380-400V 50-60Hz, D=3/PE~200-210V 50-60Hz, F=2/PE~220-240V 50-60Hz, G=3/N/PE~415V 50-60Hz, H=3/PE~220-230V 50-60Hz, K=3/PE~380-400V 50-60Hz, L=3/PE~415V 50-60Hz, M=3/PE~440V 60Hz, P=1/N/PE~220-230V 50-60Hz, R=2/PE~220-240V 50-60Hz, U=1/N/PE~240V 50-60Hz, V=3/PE~240V 50-60Hz, W=1/N/PE~100-110V 50-60Hz

09_001_e

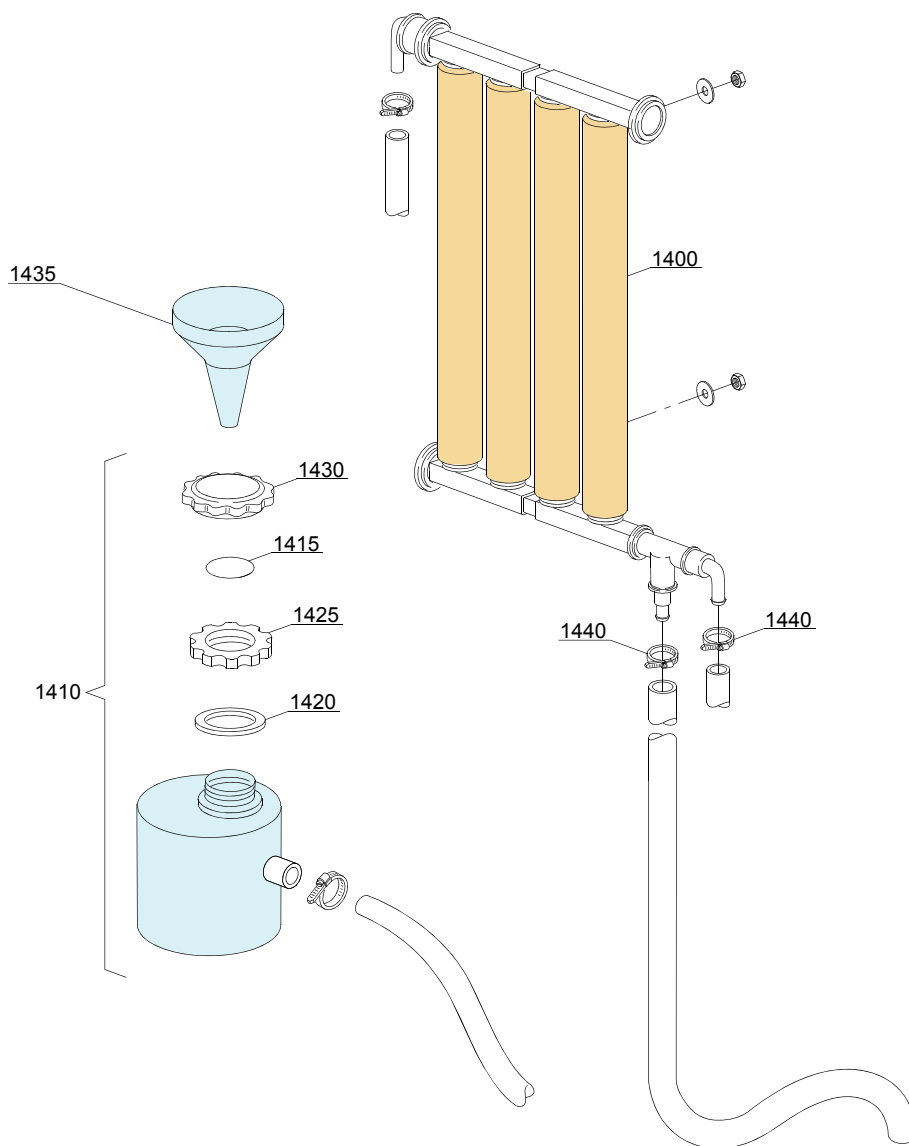

vsezip.ru

ID	P-code	SN from	SN to	Mod	Acces.	Volt	Description
Module: Water softner group							
1400	16066		-		ws		4 elements water softner
1405	16070		-		ws		Nonreturn valve
1410	16065		-		ws		Salt container
1415	16067/A		-		ws		OR O-ring
1420	16067/B		-		ws		O-ring
1425	16067/C		-		ws		Ring nut
1430	16067/D		-		ws		Plug
1435	16082		-		ws		Funnel

i=INSULATED HOOD, e=ELECTRONICAL CONTROL

110E=110E

bt=BREAK TANK, bp=BOOSTER PUMP, dvgw=DVGW, ws=WATER SOFTNER, dd=DETERGENT DISPENSER, dp=DRAIN PUMP

A=3/N/PE~380-400V 50-60Hz, D=3/PE~200-210V 50-60Hz, F=2/PE~220-240V 50-60Hz, G=3/N/PE~415V 50-60Hz, H=3/PE~220-230V 50-60Hz, K=3/PE~380-400V 50-60Hz, L=3/PE~415V 50-60Hz, M=3/PE~440V 60Hz, P=1/N/PE~220-230V 50-60Hz, R=2/PE~220-240V 50-60Hz, U=1/N/PE~240V 50-60Hz, V=3/PE~240V 50-60Hz, W=1/N/PE~100-110V 50-60Hz

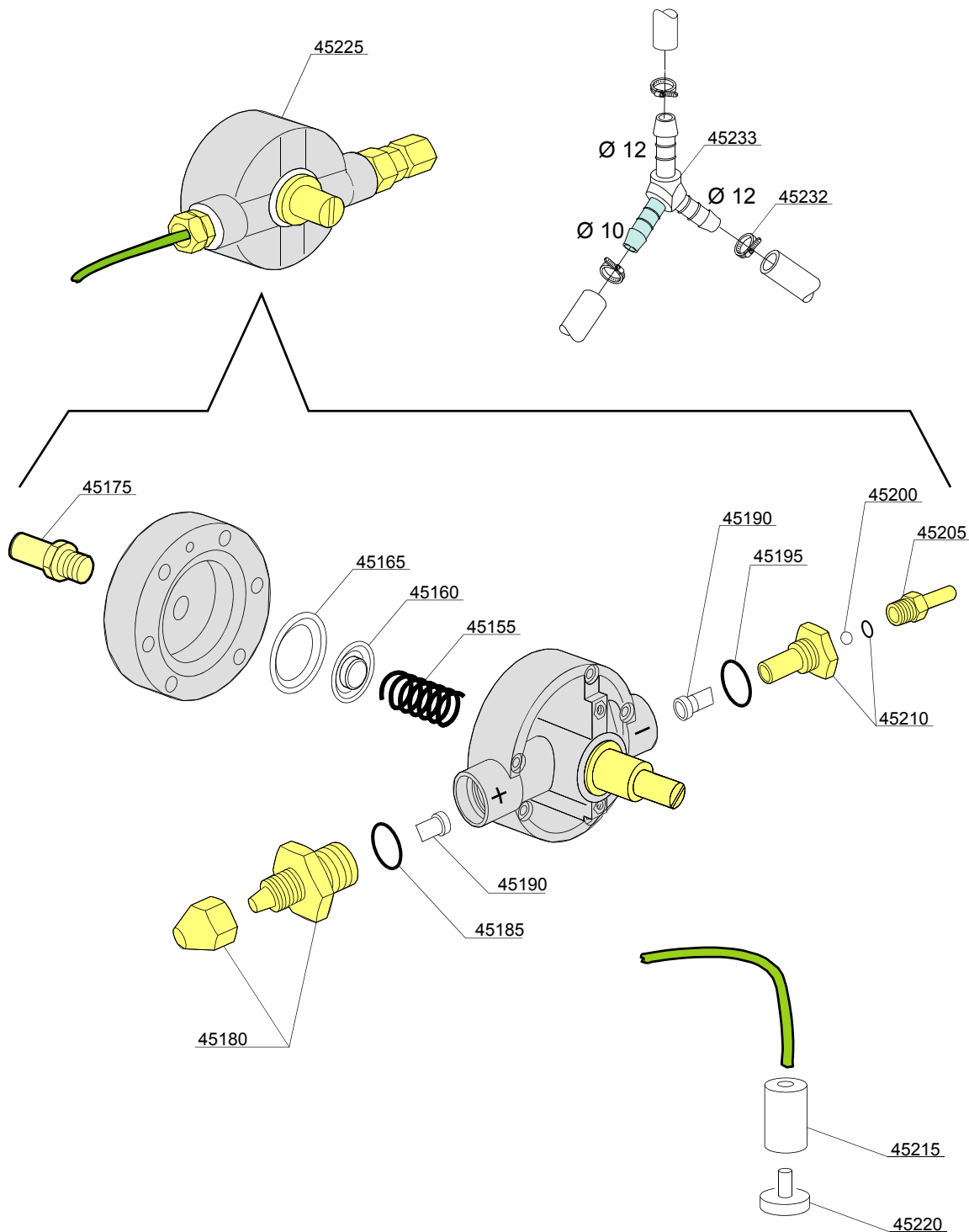

ID	P-code	SN from	SN to	Mod.	Acces.	Volt	Description
Module: Rinse aid dispenser group							
45155	10705/M		-	e			Spring
45160	10705/N		-	e			Disc to membrane
45165	10705/O		-	e			Membrane
45175	12506		-	e			Rubber-holder Ø 10mm
45180	10705/G		-	e			Pipe fitting
45185	10705/C		-	e			OR-gasket
45190	10705/D		-	e			Silicone valve
45195	10705/C		-	e			OR-gasket
45200	10705/T		-	e			Sphere made of Teflon
45205	10705/R		-	e			Brass pipe fitting
45210	10705/E		-	e			OR-gasket Guide valve
45215	12525		-	e			Ballast
45220	15058		-	e			Small filter (minimum 3 pieces)
45225	10799/G		-	e			GERMAC rinse aid dispenser
45232	11807		-	e			Clamp 12/22 (min. 3 pz)
45233	540105		-	e			Plastic 3 ways connection Ø 12-10-12

i=INSULATED HOOD, e=ELECTRONICAL CONTROL

110E=110E

bt=BREAK TANK, bp=BOOSTER PUMP, dvgw=DVGW, ws=WATER SOFTNER, dd=DETERGENT DISPENSER, dp=DRAIN PUMP

A=3/N/PE~380-400V 50-60Hz, D=3/PE~200-210V 50-60Hz, F=2/PE~220-240V 50-60Hz, G=3/N/PE~415V 50-60Hz, H=3/PE~220-230V 50-60Hz, K=3/PE~380-400V 50-60Hz, L=3/PE~415V 50-60Hz, M=3/PE~440V 60Hz, P=1/N/PE~220-230V 50-60Hz, R=2/PE~220-240V 50-60Hz, U=1/N/PE~240V 50-60Hz, V=3/PE~240V 50-60Hz, W=1/N/PE~100-110V 50-60Hz

vsezip.ru

+7(812)987-08-81

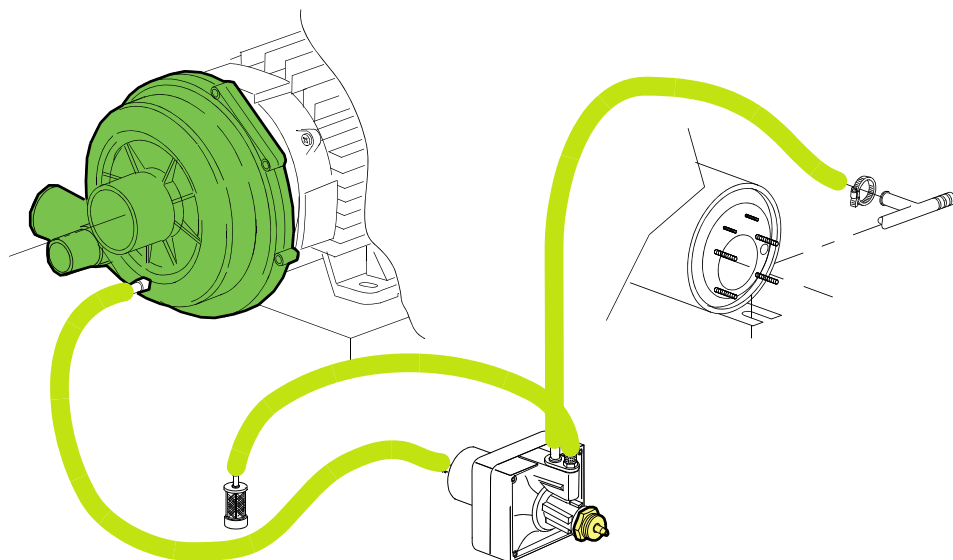
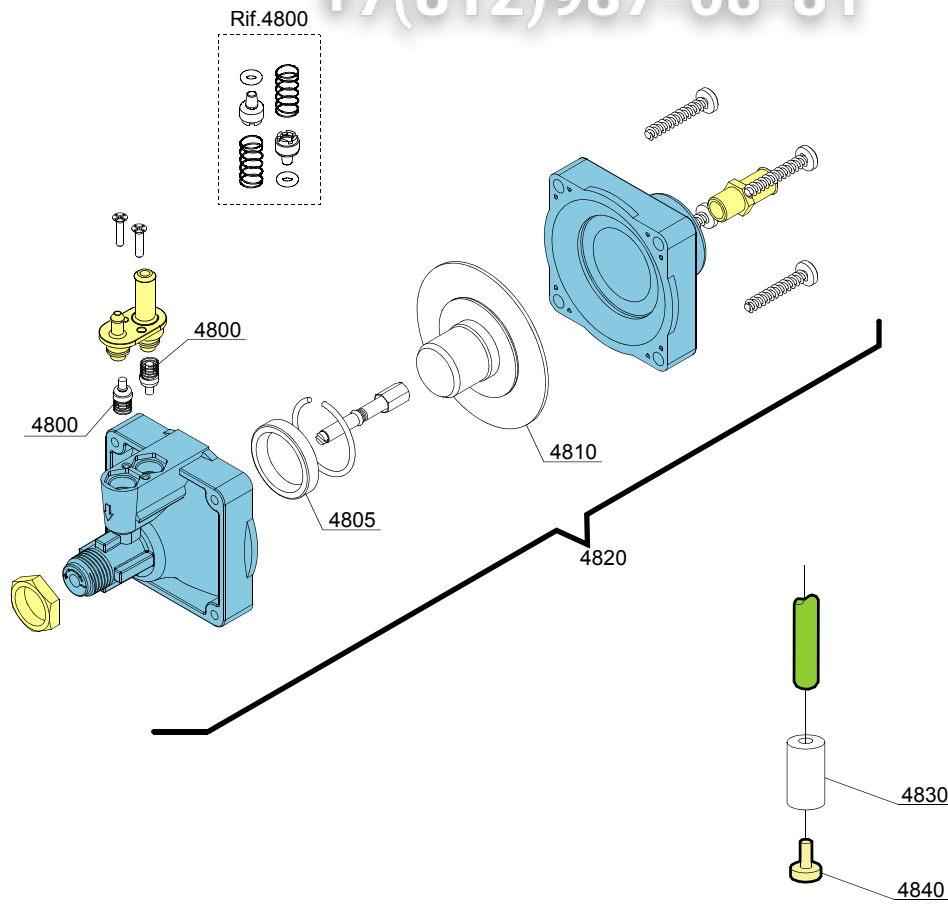

10_004ae

ID	P-code	SN from	SN to	Mod	Acces.	Volt	Description
Module: Rinse aid dispenser group							
4800	10805		-	i			Tecnopro non return valve
4805	10806		-	i			Ø22 O-ring
4810	10807		-	i			Membrane
4820	10799		-	i			Rinse aid dispenser
4830	12525		-	i			Counter-weight
4840	15058		-	i			Small filter

i=INSULATED HOOD, e=ELECTRONICAL CONTROL

110E=110E

bt=BREAK TANK, bp=BOOSTER PUMP, dvgw=DVGW, ws=WATER SOFTNER, dd=DETERGENT DISPENSER, dp=DRAIN PUMP

A=3/N/PE~380-400V 50-60Hz, D=3/PE~200-210V 50-60Hz, F=2/PE~220-240V 50-60Hz, G=3/N/PE~415V 50-60Hz, H=3/PE~220-230V 50-60Hz, K=3/PE~380-400V 50-60Hz, L=3/PE~415V 50-60Hz, M=3/PE~440V 60Hz, P=1/N/PE~220-230V 50-60Hz, R=2/PE~220-240V 50-60Hz, U=1/N/PE~240V 50-60Hz, V=3/PE~240V 50-60Hz, W=1/N/PE~100-110V 50-60Hz

vsezip.ru

+7(812)987-08-81

11_004_e

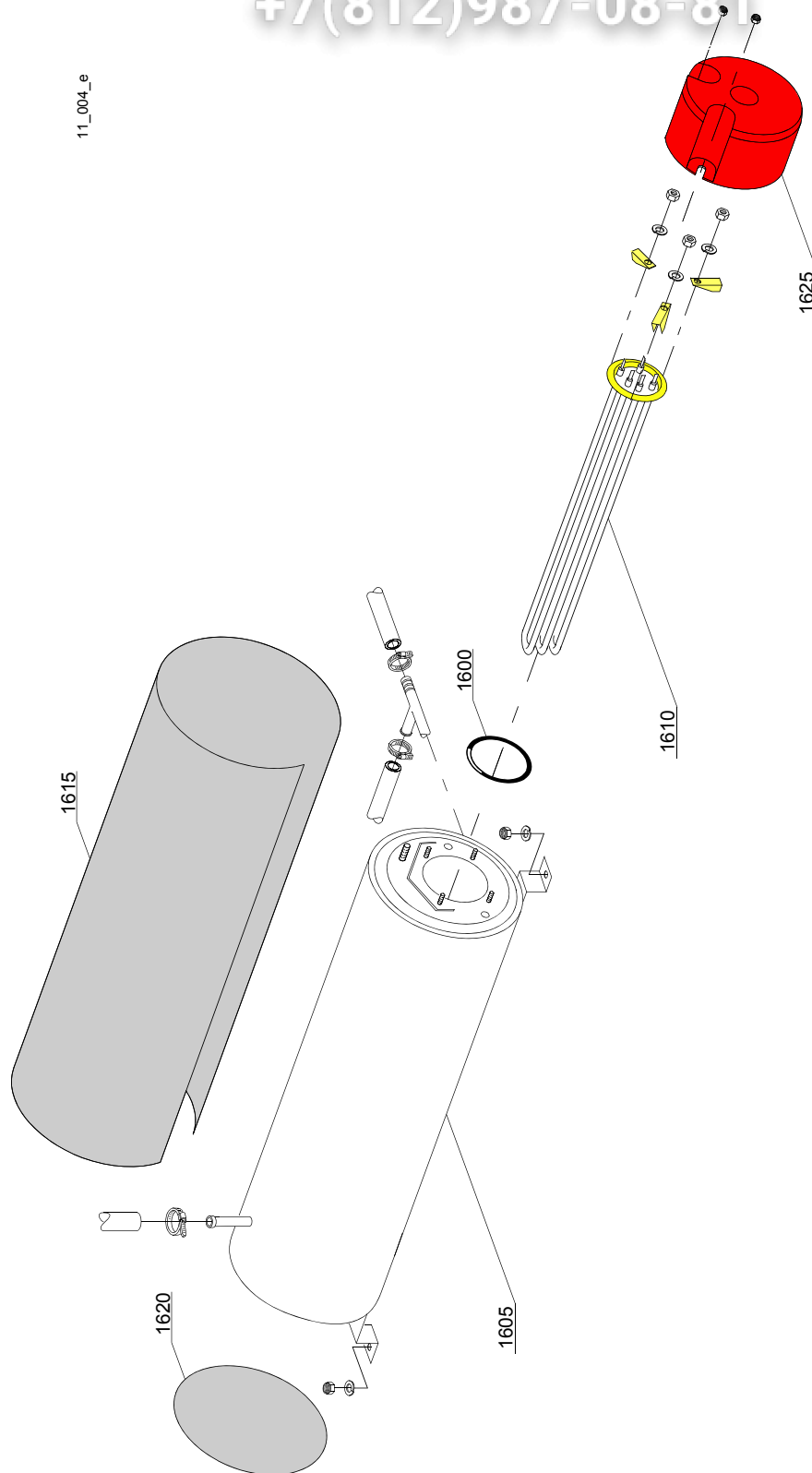

ID	P-code	SN from	SN to	Mod.	Acces.	Volt	Description
Module:Boiler group							
1600	13015		-				O-ring
1605	22002		-				Boiler
1605	75927		-				AISI 316 boiler
1610	30001010		-				6/6,53KW 230/240/3 heating element
1610	30001011		-				Element 9kW
1610	30001011/A		-				12/13,07KW 230/240V 3 heating element
1615	30002030		-				Insulation boiler
1620	75205		-				Ø160 end piece
1625	75311		-				Heating element cover

i=INSULATED HOOD, e=ELECTRONICAL CONTROL

110E=110E

bt=BREAK TANK, bp=BOOSTER PUMP, dvgw=DVGW, ws=WATER SOFTNER, dd=DETERGENT DISPENSER, dp=DRAIN PUMP

A=3/N/PE~380-400V 50-60Hz, D=3/PE~200-210V 50-60Hz, F=2/PE~220-240V 50-60Hz, G=3/N/PE~415V 50-60Hz, H=3/PE~220-230V 50-60Hz, K=3/PE~380-400V 50-60Hz, L=3/PE~415V 50-60Hz, M=3/PE~440V 60Hz, P=1/N/PE~220-230V 50-60Hz, R=2/PE~220-240V 50-60Hz, U=1/N/PE~240V 50-60Hz, V=3/PE~240V 50-60Hz, W=1/N/PE~100-110V 50-60Hz

vsezip.ru

+7(812)987-08-81

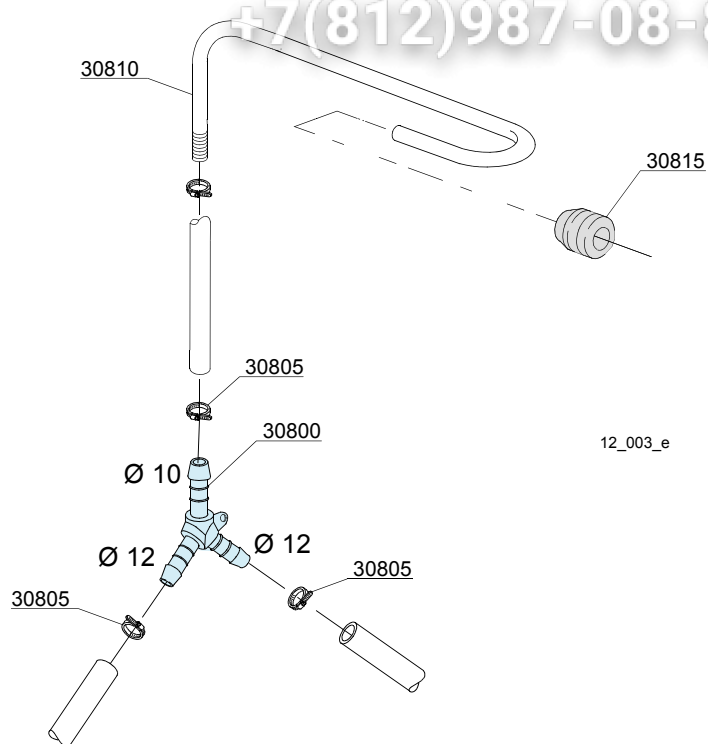

vsezip.ru

ID	P-code	SN from	SN to	Mod	Acces.	Volt	Description
Module:3 ways connection							
30800	540104		-	i			Ø10-12-12 mm plastic 3 ways connection
30805	11807		-	i			Clamp
30810	76082		-	i			Rinse pipe
30815	13304		-	i			Pipe

i=INSULATED HOOD, e=ELECTRONICAL CONTROL

110E=110E

bt=BREAK TANK, bp=BOOSTER PUMP, dvgw=DVGW, ws=WATER SOFTNER, dd=DETERGENT DISPENSER, dp=DRAIN PUMP

A=3/N/PE~380-400V 50-60Hz, D=3/PE~200-210V 50-60Hz, F=2/PE~220-240V 50-60Hz, G=3/N/PE~415V 50-60Hz, H=3/PE~220-230V 50-60Hz, K=3/PE~380-400V 50-60Hz, L=3/PE~415V 50-60Hz, M=3/PE~440V 60Hz, P=1/N/PE~220-230V 50-60Hz, R=2/PE~220-240V 50-60Hz, U=1/N/PE~240V 50-60Hz, V=3/PE~240V 50-60Hz, W=1/N/PE~100-110V 50-60Hz

vsezip.ru

+7(812)987-08-81

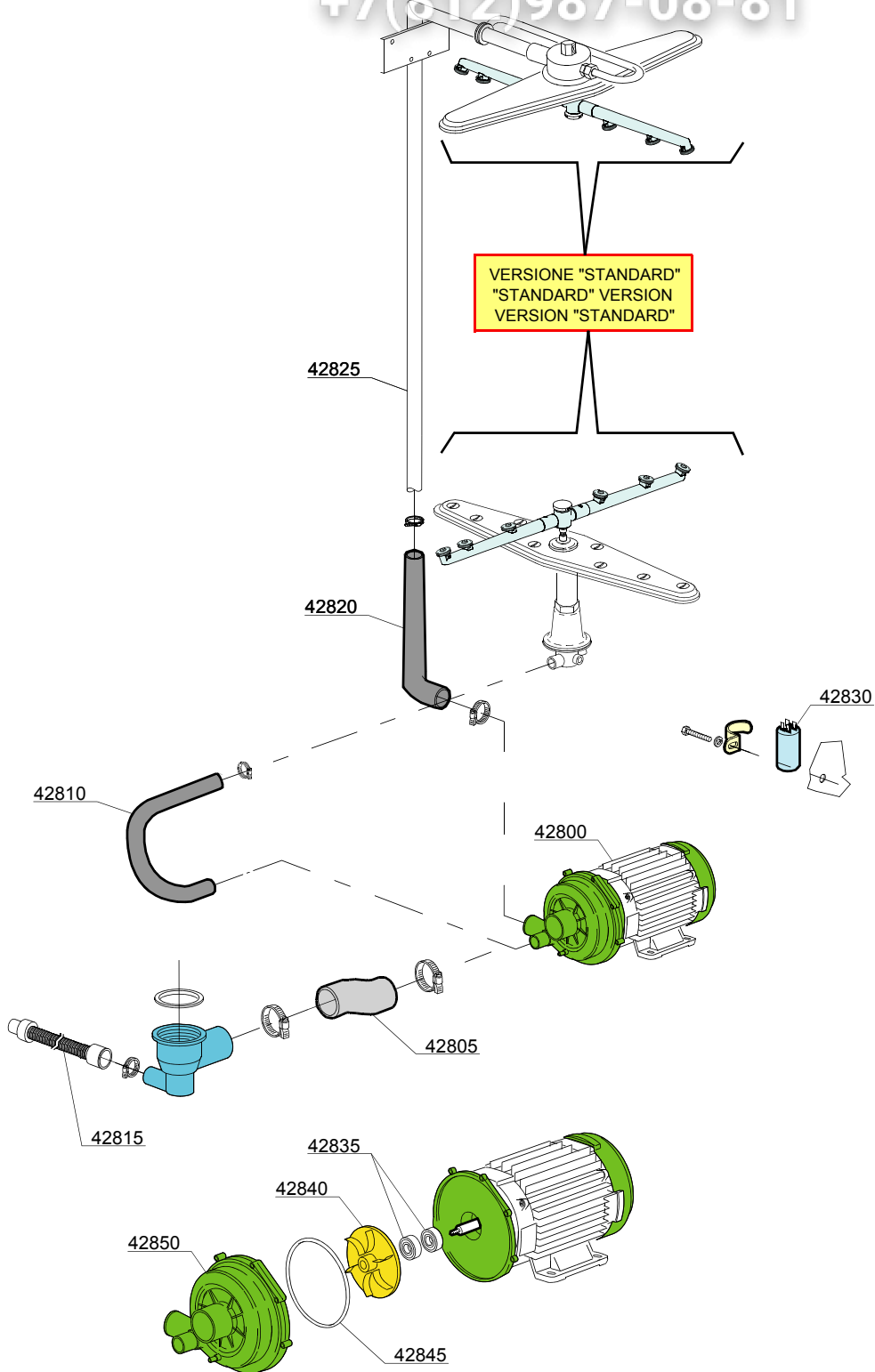

13_124ce

vsezip.ru

ID	P-code	SN from	SN to	Mod.	Acces.	Volt	Description
Module: Wash pump group							
42800	22009		-			A	pump 1,5Hp/1,1kW 50Hz
42800	22041		-				pump 1,5Hp/1,1kW - 380/3Vac 50Hz
42805	25032		-				Suction pipe coupling
42810	15033/A		-				Lower delivery wash pipe
42815	10727		-				Drain pipe
42820	76078		-				Top delivery pipe
42825	11600103		-				Wash ramp
42830	15081/A		-				Condenser 16 uF
42835	15080/E		-				Rotating seals
42840	22009/A		-				Pump rotor
42845	15080/A		-				O-ring
42850	15078		-				Scroll

i=INSULATED HOOD, e=ELECTRONICAL CONTROL

110E=110E

bt=BREAK TANK, bp=BOOSTER PUMP, dvgw=DVGW, ws=WATER SOFTNER, dd=DETERGENT DISPENSER, dp=DRAIN PUMP

A=3/N/PE~380-400V 50-60Hz, D=3/PE~200-210V 50-60Hz, F=2/PE~220-240V 50-60Hz, G=3/N/PE~415V 50-60Hz, H=3/PE~220-230V 50-60Hz, K=3/PE~380-400V 50-60Hz, L=3/PE~415V 50-60Hz, M=3/PE~440V 60Hz, P=1/N/PE~220-230V 50-60Hz, R=2/PE~220-240V 50-60Hz, U=1/N/PE~240V 50-60Hz, V=3/PE~240V 50-60Hz, W=1/N/PE~100-110V 50-60Hz

vsezip.ru

+7(812)987-08-81

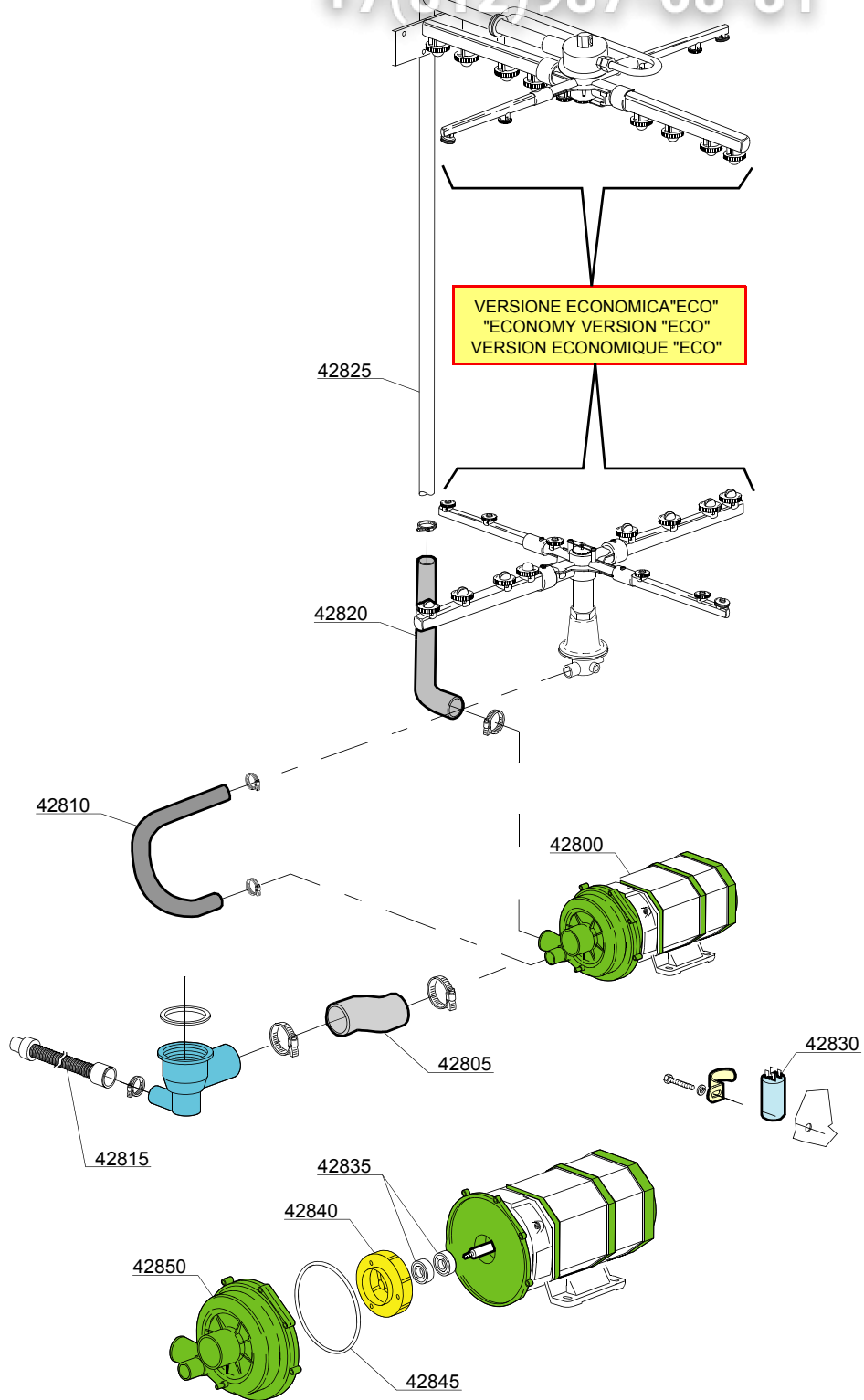

13_124ae

vsezip.ru

ID	P-code	SN from	SN to	Mod.	Acces.	Volt	Description
Module: Wash pump group							
42800	15913		-				wash pump 1,2Hp/0,9kW 50Hz
42805	25032		-				Suction pipe coupling
42810	15033/A		-				Lower delivery wash pipe
42815	10727		-				Drain pipe
42820	76078		-				Top delivery pipe
42825	11600103		-				Wash ramp
42830	15081/A		-				Condenser 16 uF
42835	15080/E		-				Rotating seals
42840	15079/C		-				Closed Ø 110 Pump rotor
42845	15080/A		-				O-ring
42850	15078		-				Scroll

i=INSULATED HOOD, e=ELECTRONICAL CONTROL

110E=110E

bt=BREAK TANK, bp=BOOSTER PUMP, dvgw=DVGW, ws=WATER SOFTNER, dd=DETERGENT DISPENSER, dp=DRAIN PUMP

A=3/N/PE~380-400V 50-60Hz, D=3/PE~200-210V 50-60Hz, F=2/PE~220-240V 50-60Hz, G=3/N/PE~415V 50-60Hz, H=3/PE~220-230V 50-60Hz, K=3/PE~380-400V 50-60Hz, L=3/PE~415V 50-60Hz, M=3/PE~440V 60Hz, P=1/N/PE~220-230V 50-60Hz, R=2/PE~220-240V 50-60Hz, U=1/N/PE~240V 50-60Hz, V=3/PE~240V 50-60Hz, W=1/N/PE~100-110V 50-60Hz

vsezip.ru

+7(812)987-08-81

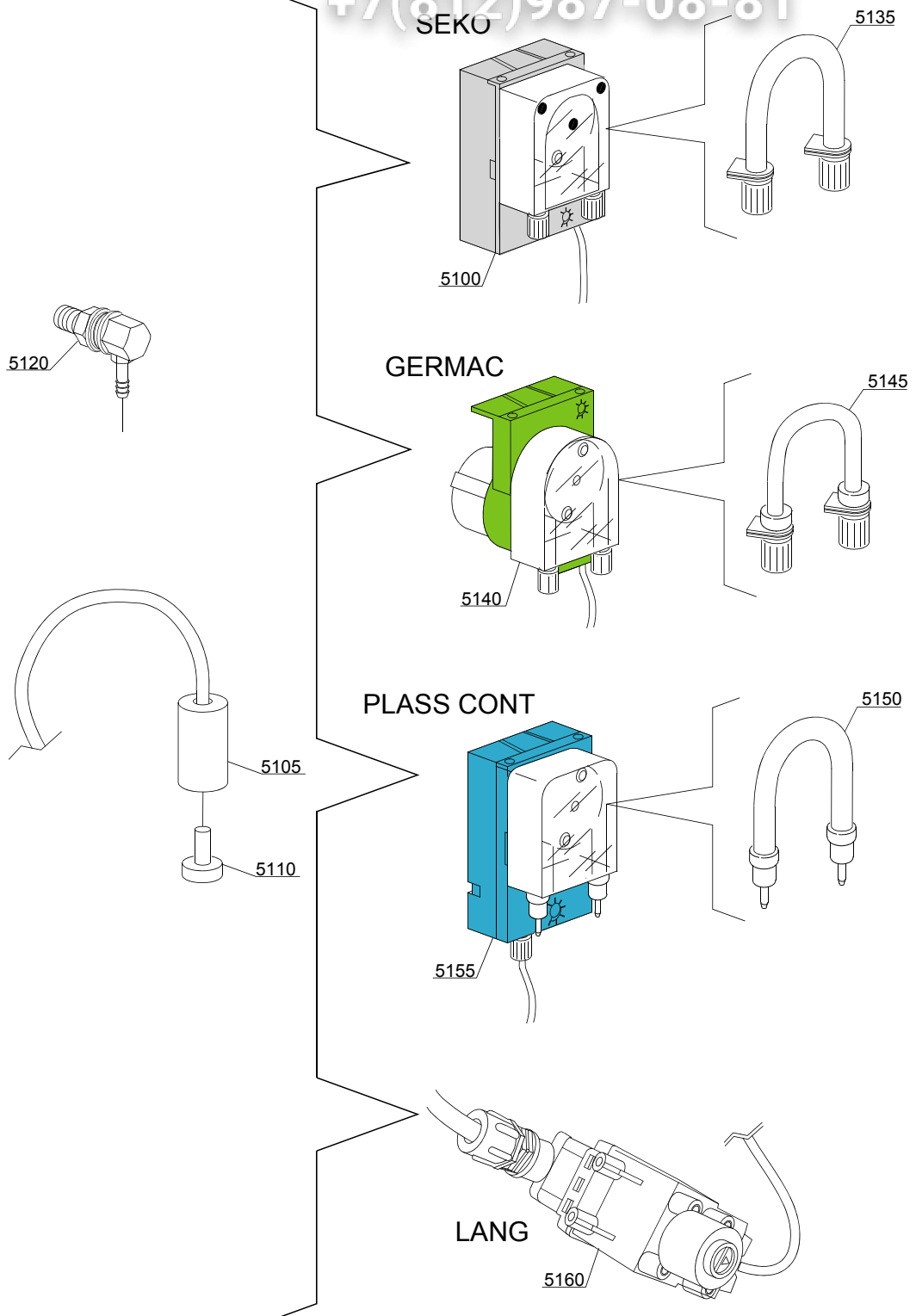

14_004_e

ID	P-code	SN from	SN to	Mod.	Acces.	Volt	Description
Module:Dosing detergent group							
5100	15985		-	i	dd		Seko detergent pump
5105	12525		-	i	dd		Counter-weight
5110	15058		-	i	dd		Small filter
5120	15123		-	i	dd		Complet Steel injector
5125	15159		-	i	dd		OR O-ring
5130	10200205		-	i	dd		M12x1 stainless steel nut
5135	15185		-	i	dd		Seko thermoplastic pipe Ø 10
5140	15985		-	i	dd		Germac detergent pump
5145	15108/E		-	i	dd		Germac thermoplastic pipe Ø 8
5150	15985/A		-	i	dd		Ø 10 PLAS CONT thermoplastic pipe
5155	15985		-	i	dd		PLAS CONT detergent pump
5160	15108/L		-	i	dd		LANG detergent pump

i=INSULATED HOOD, e=ELECTRONICAL CONTROL

110E=110E

bt=BREAK TANK, bp=BOOSTER PUMP, dvgw=DVGW, ws=WATER SOFTNER, dd=DETERGENT DISPENSER, dp=DRAIN PUMP

A=3/N/PE~380-400V 50-60Hz, D=3/PE~200-210V 50-60Hz, F=2/PE~220-240V 50-60Hz, G=3/N/PE~415V 50-60Hz, H=3/PE~220-230V 50-60Hz, K=3/PE~380-400V 50-60Hz, L=3/PE~415V 50-60Hz, M=3/PE~440V 60Hz, P=1/N/PE~220-230V 50-60Hz, R=2/PE~220-240V 50-60Hz, U=1/N/PE~240V 50-60Hz, V=3/PE~240V 50-60Hz, W=1/N/PE~100-110V 50-60Hz

15_003pe

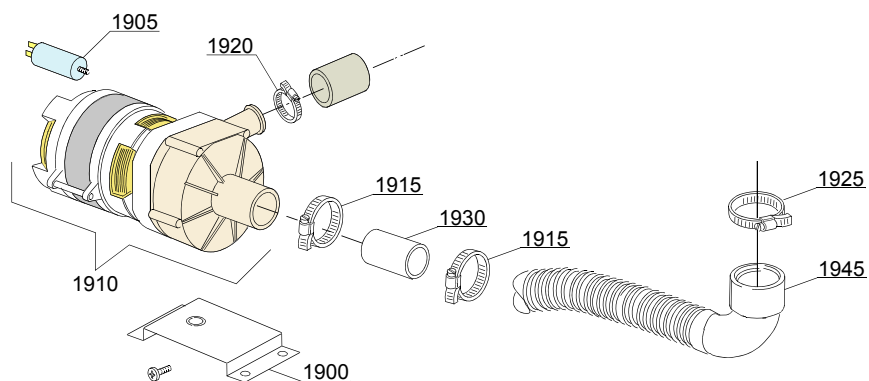

vsezip.ru

ID	P-code	SN from	SN to	Mod.	Acces.	Volt	Description
Module: Drain pump group							
1900	440122		-		dp		Pump support
1905	10702		-		dp		5 uF condenser
1910	10501/A		-		dp		Drain pump (extra equipment)
1910	10501/D		-		dp		Drain pump 80W 220V 60Hz
1915	11806		-		dp		25/40 clamp
1920	11836		-		dp		20/32 clamp
1950	18044		-		dp		Ø 28 Top pipe

i=INSULATED HOOD, e=ELECTRONICAL CONTROL

110E=110E

bt=BREAK TANK, bp=BOOSTER PUMP, dvgw=DVGW, ws=WATER SOFTNER, dd=DETERGENT DISPENSER, dp=DRAIN PUMP

A=3/N/PE~380-400V 50-60Hz, D=3/PE~200-210V 50-60Hz, F=2/PE~220-240V 50-60Hz, G=3/N/PE~415V 50-60Hz, H=3/PE~220-230V 50-60Hz, K=3/PE~380-400V 50-60Hz, L=3/PE~415V 50-60Hz, M=3/PE~440V 60Hz, P=1/N/PE~220-230V 50-60Hz, R=2/PE~220-240V 50-60Hz, U=1/N/PE~240V 50-60Hz, V=3/PE~240V 50-60Hz, W=1/N/PE~100-110V 50-60Hz

vsezip.ru

+7(812)987-08-81

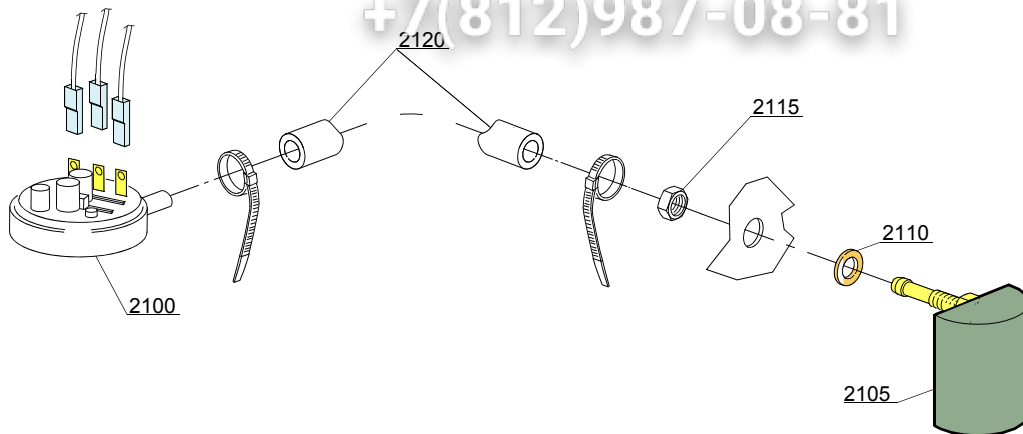

16_001_e

ID	P-code	SN from	SN to	Mod	Acces.	Volt	Description
Module: Pressure switch group with air trap							
2100	10706/A		-				Pressure switch 47-27
2100	75950		-				Pressure switch PR
2105	135911/B		-				Air trap
2110	13301		-	i			Gasket
2115	11702		-	i			Nut

i=INSULATED HOOD, e=ELECTRONICAL CONTROL

110E=110E

bt=BREAK TANK, bp=BOOSTER PUMP, dvgw=DVGW, ws=WATER SOFTNER, dd=DETERGENT DISPENSER, dp=DRAIN PUMP

A=3/N/PE~380-400V 50-60Hz, D=3/PE~200-210V 50-60Hz, F=2/PE~220-240V 50-60Hz, G=3/N/PE~415V 50-60Hz, H=3/PE~220-230V 50-60Hz, K=3/PE~380-400V 50-60Hz, L=3/PE~415V 50-60Hz, M=3/PE~440V 60Hz, P=1/N/PE~220-230V 50-60Hz, R=2/PE~220-240V 50-60Hz, U=1/N/PE~240V 50-60Hz, V=3/PE~240V 50-60Hz, W=1/N/PE~100-110V 50-60Hz

vsezip.ru

+7(812)987-08-81

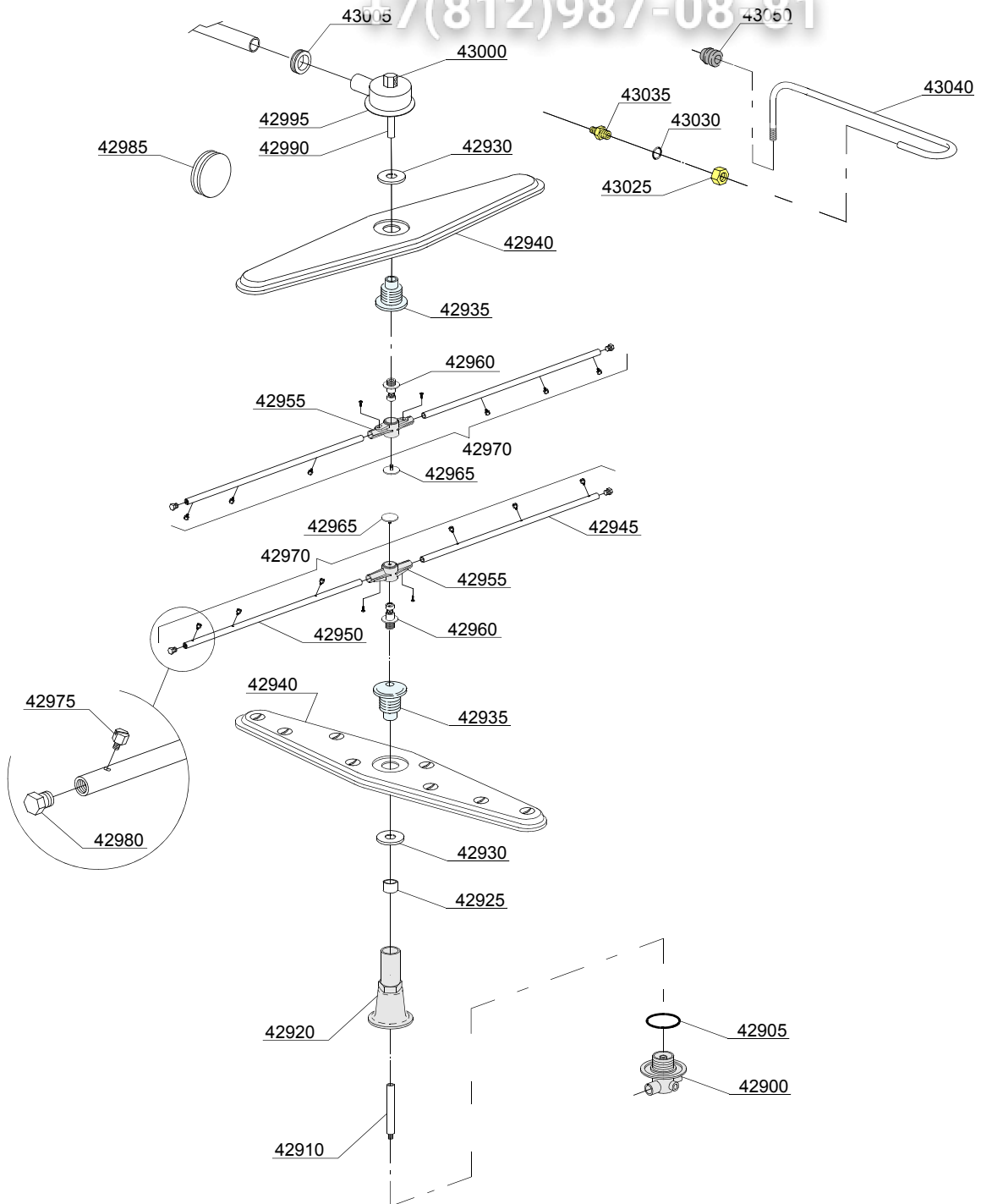

17_129_e

ID	P-code	SN from	SN to	Mod.	Acces.	Volt	Description
Module: Turret group with rotating arms							
42900	500612		-				Top/lower turret
42905	13015		-				6225 OR 160 NBR O-ring
42910	76079		-				Rinse axle
42920	76077		-				Lower pipe coupling
42925	75321		-				Spacer for hub
42930	75317		-				Nut for wash arm bearing
42935	75320		-				Wash arm bearing
42940	75915		-				Stainless steel wash rotor
42945	10657		-				Right rinse arm - stainless steel nozzle
42950	10658		-				Left rinse arm - stainless steel nozzle
42955	10650		-				Rinse arm
42960	10651		-				Rinse axle
42965	10652		-				Rinse arm screw
42970	75918		-				Top/lower rinse arm complete
42975	560018		-				Stainless steel rinse nozzle
42980	560017		-				Rinse arm plug
42985	13316/A		-				DVGW hole O-ring
42990	75322		-				Top rinse axle
42995	75067		-				Stainless steel turret
43000	75319		-				Rinse elbow
43005	76081		-				Pipe-pass O-ring 51x34x14
43025	12006/A		-				Ø10 pipe fitting 3/8x3,5 nut 19 hexagonal
43030	13003		-				OR 112 NBR O-ring
43035	12006		-				Ø10 rinse pipe fitting
43040	76082		-				Top rinse pipe
43050	13304		-				Pipe-pass O-ring

i=INSULATED HOOD, e=ELECTRONICAL CONTROL

110E=110E

bt=BREAK TANK, bp=BOOSTER PUMP, dvgw=DVGW, ws=WATER SOFTNER, dd=DETERGENT DISPENSER, dp=DRAIN PUMP

A=3/N/PE~380-400V 50-60Hz, D=3/PE~200-210V 50-60Hz, F=2/PE~220-240V 50-60Hz, G=3/N/PE~415V 50-60Hz, H=3/PE~220-230V 50-60Hz, K=3/PE~380-400V 50-60Hz, L=3/PE~415V 50-60Hz, M=3/PE~440V 60Hz, P=1/N/PE~220-230V 50-60Hz, R=2/PE~220-240V 50-60Hz, U=1/N/PE~240V 50-60Hz, V=3/PE~240V 50-60Hz, W=1/N/PE~100-110V 50-60Hz

vsezip.ru

+7(812)987-08-81

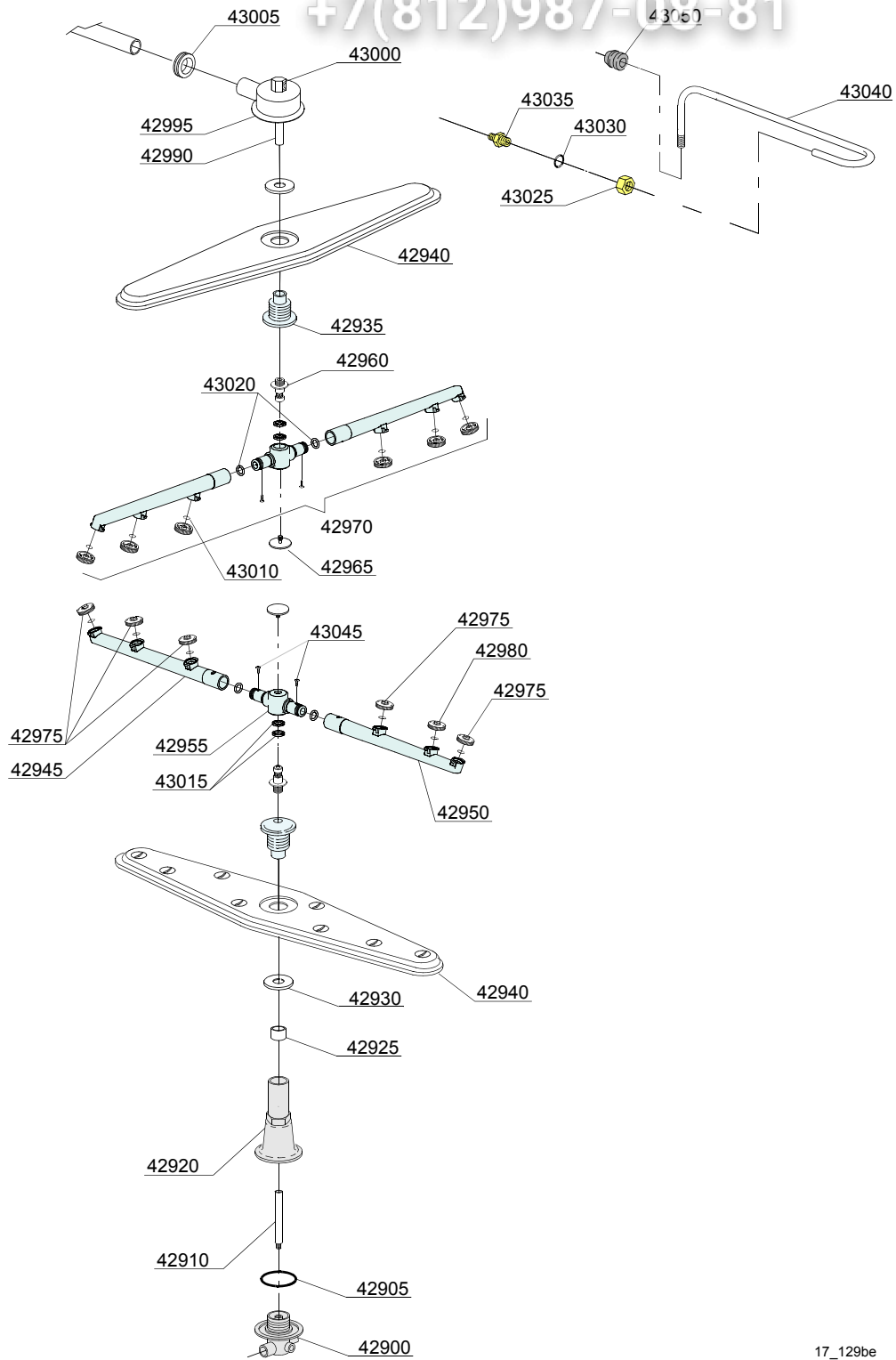

17_129be

ID	P-code	SN from	SN to	Mod.	Acces.	Volt	Description
Module:Turret group with rotating arms							
42900	500612		-				Top/lower turret
42905	13015		-				6225 OR 160 NBR O-ring
42910	76079		-				Rinse axle
42920	76077		-				Lower pipe coupling
42925	75321		-				Spacer for hub
42930	75317		-				Nut for wash arm bearing
42935	75320		-				Wash arm bearing
42940	75915		-				Stainless steel wash rotor
42945	75920/D		-				Right rinse arm - stainless steel nozzle
42950	75920/S		-				Left rinse arm - stainless steel nozzle
42955	75920/A		-				Rinse arm
42960	10651		-				Rinse axle
42965	10652		-				Rinse arm screw
42970	75920		-				Top/lower rinse arm complete
42975	10371		-				Open rinse nozzle
42980	10372		-				Closed rinse nozzle
42990	75322		-				Top rinse axle
42995	75067		-				Stainless steel turret
43000	75319		-				Rinse elbow
43005	76081		-				Pipe-pass O-ring 51x34x14
43010	13002		-				OR R6 NBR O-ring (minimum 10 pieces)
43015	75920/B		-				O ring for hub (rinse arm)
43020	13002		-				OR R6 NBR O-ring (minimum 10 pieces)
43025	12006/A		-				Ø10 pipe fitting 3/8x3,5 nut 19 hexagonal
43030	13003		-				OR 112 NBR O-ring
43035	12006		-				Ø10 rinse pipe fitting
43040	76082		-				Top rinse pipe
43045	11004		-				4x10 TCB Ø8 spax toothed screw

i=INSULATED HOOD, e=ELECTRONICAL CONTROL

110E=110E

bt=BREAK TANK, bp=BOOSTER PUMP, dvgw=DVGW, ws=WATER SOFTNER, dd=DETERGENT DISPENSER, dp=DRAIN PUMP

A=3/N/PE~380-400V 50-60Hz, D=3/PE~200-210V 50-60Hz, F=2/PE~220-240V 50-60Hz, G=3/N/PE~415V 50-60Hz, H=3/PE~220-230V 50-60Hz, K=3/PE~380-400V 50-60Hz, L=3/PE~415V 50-60Hz, M=3/PE~440V 60Hz, P=1/N/PE~220-230V 50-60Hz, R=2/PE~220-240V 50-60Hz, U=1/N/PE~240V 50-60Hz, V=3/PE~240V 50-60Hz, W=1/N/PE~100-110V 50-60Hz

vsezip.ru

+7(812)987-08-81

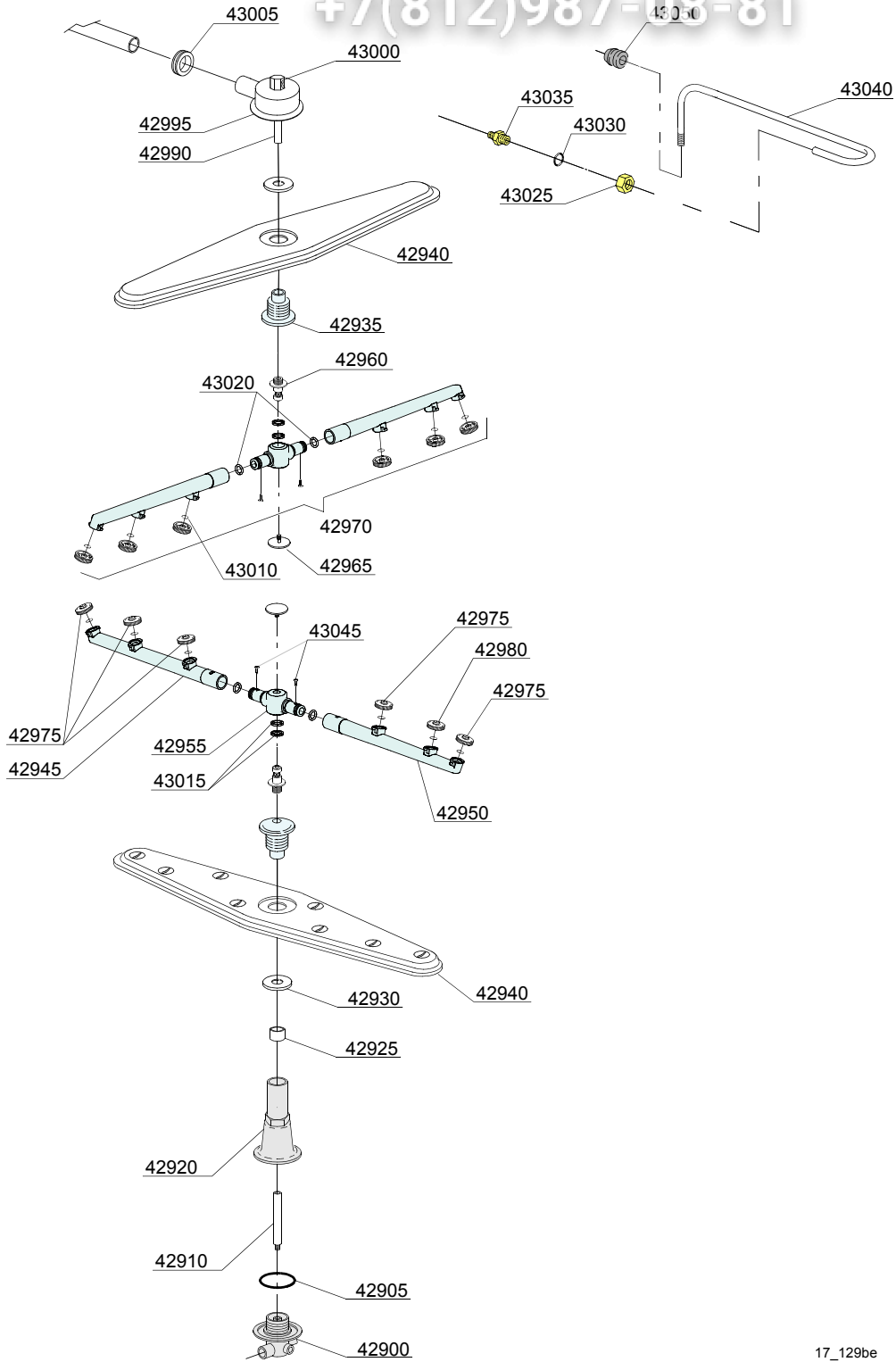

17_129be

vsezip.ru

ID	P-code	SN from	SN to	Mod.	Acces	Volt	Description
Module:Turret group with rotating arms							
43050	13304		-				Pipe-pass O-ring

i=INSULATED HOOD, e=ELECTRONICAL CONTROL

110E=110E

bt=BREAK TANK, bp=BOOSTER PUMP, dvgw=DVGW, ws=WATER SOFTNER, dd=DETERGENT DISPENSER, dp=DRAIN PUMP

A=3/N/PE~380-400V 50-60Hz, D=3/PE~200-210V 50-60Hz, F=2/PE~220-240V 50-60Hz, G=3/N/PE~415V 50-60Hz, H=3/PE~220-230V 50-60Hz, K=3/PE~380-400V 50-60Hz, L=3/PE~415V 50-60Hz, M=3/PE~440V 60Hz, P=1/N/PE~220-230V 50-60Hz, R=2/PE~220-240V 50-60Hz, U=1/N/PE~240V 50-60Hz, V=3/PE~240V 50-60Hz, W=1/N/PE~100-110V 50-60Hz

ID	P-code	SN from	SN to	Mod	Acces.	Volt	Description
Module:Turret group with rotating arms							
47250	500612		-	e			Top/lower turret
47255	13015		-	e			6225 OR 160 NBR O-ring
47260	76084		-	e			Inferior rinse axle
47265	15300		-	e			Ø10x51 lower/top rinse axle
47266	76085		-	e			Top rinse axle
47270	76077		-	e			Lower pipe coupling
47275	76083		-	e			Stainless steel turret
47280	75319		-	e			Rinse elbow
47285	13304		-	e			Pipe-pass O-ring
47290	12006		-	e			Ø10 rinse pipe fitting
47295	13003		-	e			OR 112 NBR O-ring
47300	12006/A		-	e			Ø10 pipe fitting 3/8x3,5 nut 19 hexagonal
47305	76082		-	e			Top rinse pipe
47310	13316/A		-	e			DVGW hole O-ring
47315	13319		-	e			Sliding washer (minimum 4 pieces)
47320	11101/I		-	e			Stainless steel group fixing screw
47325	10260		-	e			Blocking ring nut rotor plaque (minimum 10 pieces)
47330	11004		-	e			4x10 TCB Ø8 spax toothed screw
47335	50755		-	e			Under / upper turret wash rotor
47340	11004		-	e			4x10 TCB Ø8 spax toothed screw
47345	500751		-	e			Right rinse arm
47350	500752		-	e			Left rinse arm
47355	500753		-	e			Right wash pipe
47360	500754		-	e			Left wash pipe
47365	13002		-	e			OR R6 NBR O-ring (minimum 10 pieces)
47370	13025		-	e			OR 2081 O-ring (minimum 10 pieces)
47375	13009		-	e			OR 2050 NBR O-ring (minimum 10 pieces)
47380	10369		-	e			Opened wash nozzle (minimum 2 pieces)

i=INSULATED HOOD, e=ELECTRONICAL CONTROL

110E=110E

bt=BREAK TANK, bp=BOOSTER PUMP, dvgw=DVGW, ws=WATER SOFTNER, dd=DETERGENT DISPENSER, dp=DRAIN PUMP

A=3/N/PE~380-400V 50-60Hz, D=3/PE~200-210V 50-60Hz, F=2/PE~220-240V 50-60Hz, G=3/N/PE~415V 50-60Hz, H=3/PE~220-230V 50-60Hz, K=3/PE~380-400V 50-60Hz, L=3/PE~415V 50-60Hz, M=3/PE~440V 60Hz, P=1/N/PE~220-230V 50-60Hz, R=2/PE~220-240V 50-60Hz, U=1/N/PE~240V 50-60Hz, V=3/PE~240V 50-60Hz, W=1/N/PE~100-110V 50-60Hz

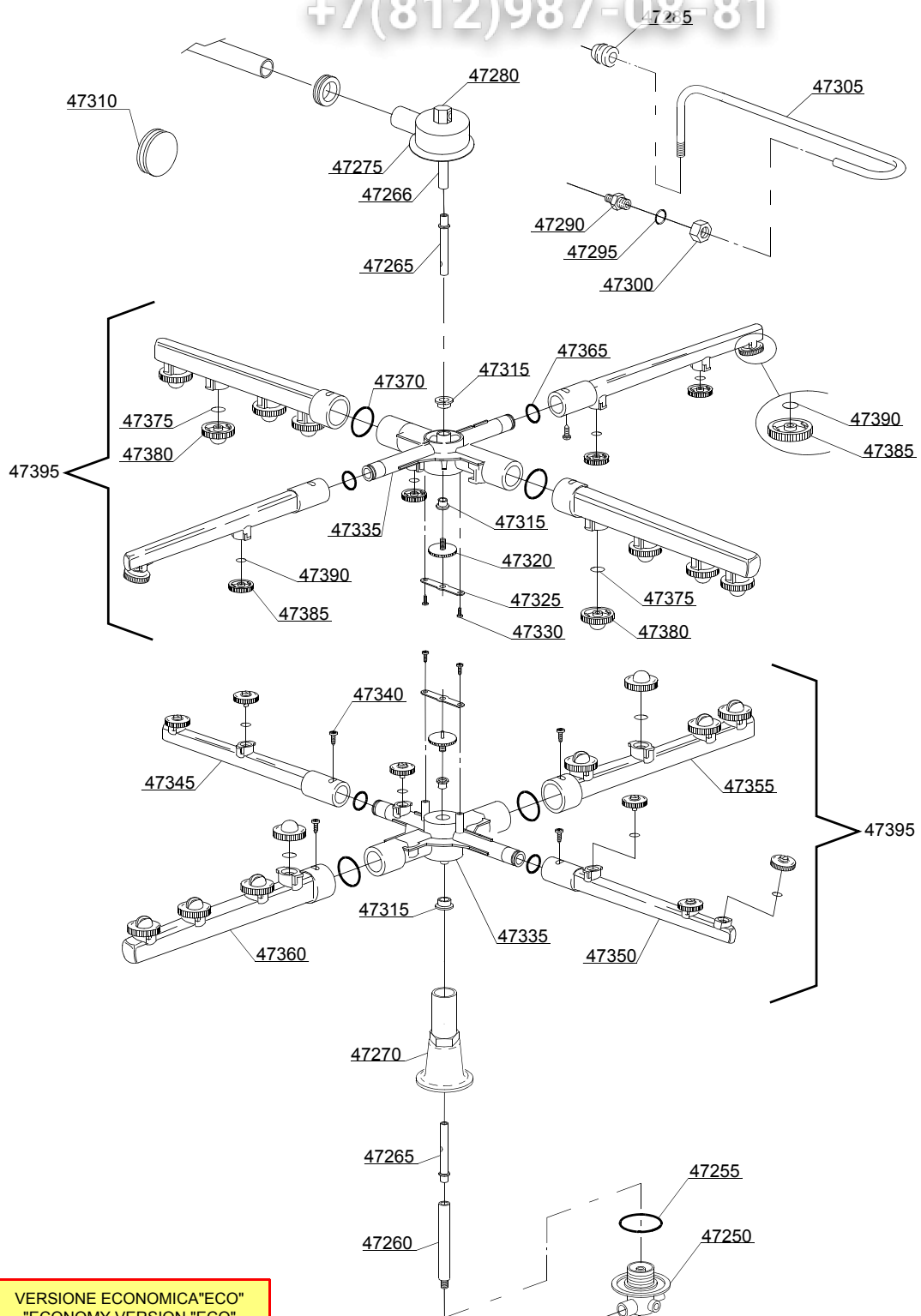

VERSIONE ECONOMICA "ECO"
 "ECONOMY VERSION "ECO"
 VERSION ECONOMIQUE "ECO"

vsezip.ru

ID	P-code	SN from	SN to	Mod.	Acces.	Volt	Description
Module:Turret group with rotating arms							
47385	10371		-	e			Rinse nozzle
47390	13002		-	e			OR R6 NBR O-ring (minimum 10 pieces)
47395	500750		-	e			Grey wash/rinse lower/upper distributor

i=INSULATED HOOD, e=ELECTRONICAL CONTROL

110E=110E

bt=BREAK TANK, bp=BOOSTER PUMP, dvgw=DVGW, ws=WATER SOFTNER, dd=DETERGENT DISPENSER, dp=DRAIN PUMP

A=3/N/PE~380-400V 50-60Hz, D=3/PE~200-210V 50-60Hz, F=2/PE~220-240V 50-60Hz, G=3/N/PE~415V 50-60Hz, H=3/PE~220-230V 50-60Hz, K=3/PE~380-400V 50-60Hz, L=3/PE~415V 50-60Hz, M=3/PE~440V 60Hz, P=1/N/PE~220-230V 50-60Hz, R=2/PE~220-240V 50-60Hz, U=1/N/PE~240V 50-60Hz, V=3/PE~240V 50-60Hz, W=1/N/PE~100-110V 50-60Hz