

Вит Общепит  
+7(812)987-08-81

**LAVABICCHIERI  
GLASS WASHERS  
LAVE VERRES**

**42  
alt**

**- 48 - 55 - 60 - 42E - 48E**

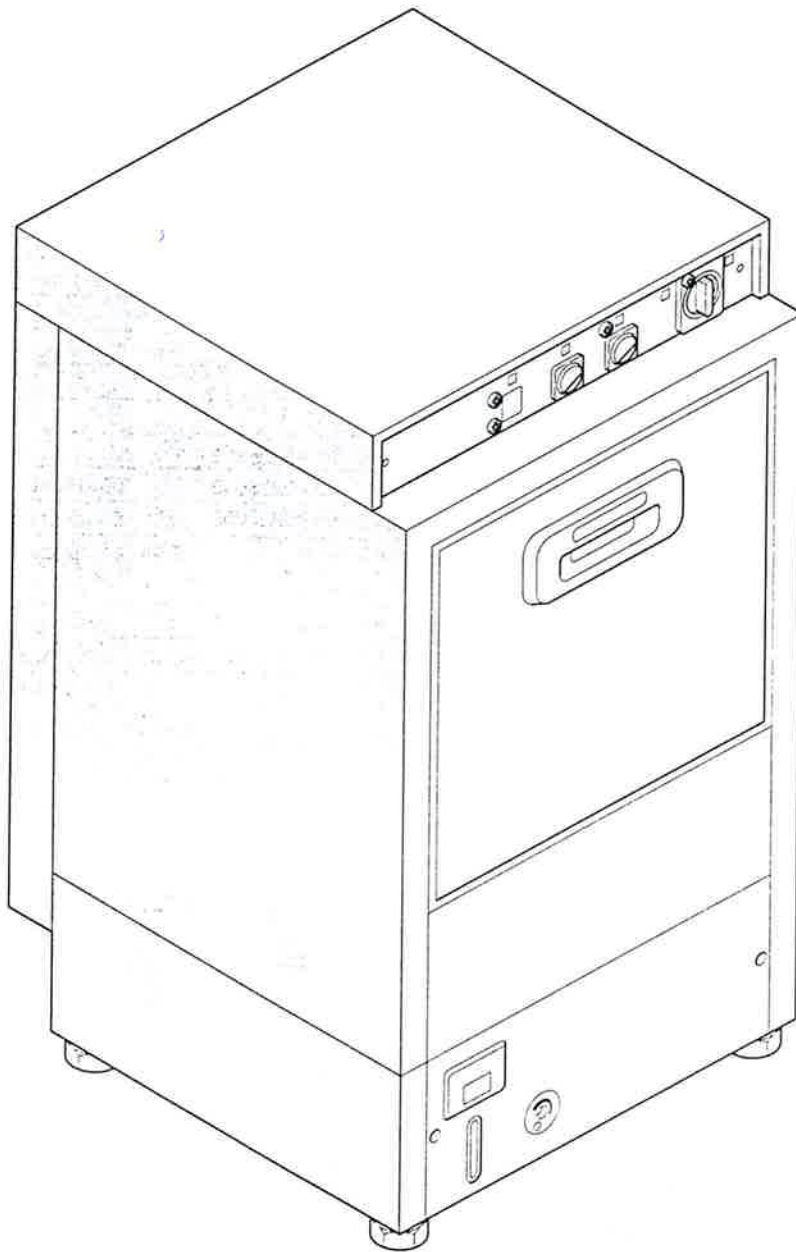

10/95



NUOVA **elframo** S.R.L.

24127 BERGAMO (ITALIA) - VIA VERGA, 24  
TELEFONO 035/4548111 - TELEFAX 035/4548150



RUSSIA  
**elcamo** S.R.L.

3ip. Общепит  
**LAVABICCHIERI**  
**42-48-55-60-42E-48E**  
vsezip.ru

**TAV. 1**

+7(812)987-08-81

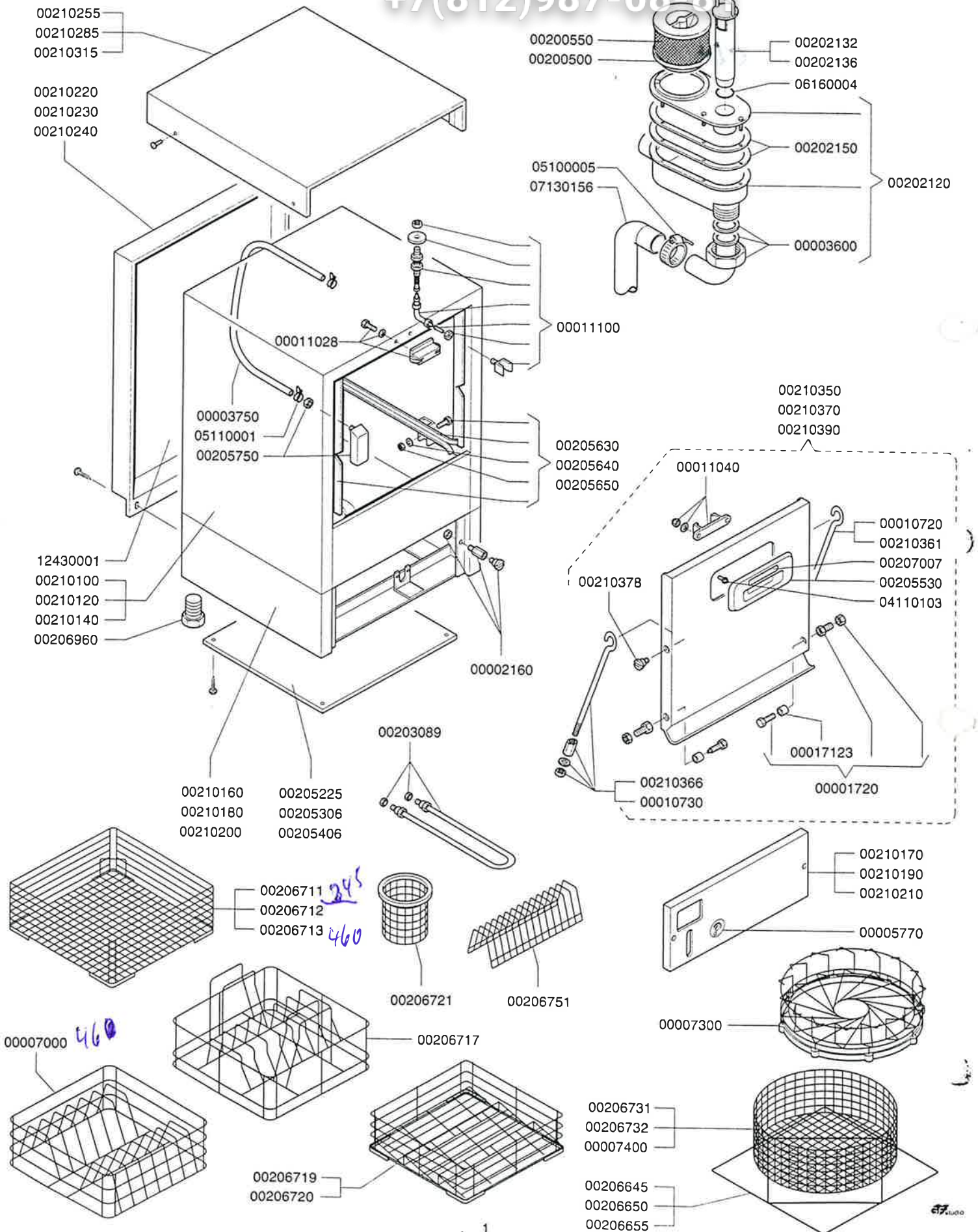

**DISTINTA PER RICAMBIO** (Per l'ordinazione riferire sempre il tipo/modello e l'anno di fabbricazione)  
**SPARE PARTS LIST** (When ordering pls always indicate type/model and production year)  
**LISTE PIÈCES DÉTACHÉES** (En cas de commande indiquer le modèle et l'année de fabrication)

TAV.

1

COD.	DENOMINAZIONE	DENOMINATION	DÉNOMINATION
00001720	Gruppo cerniere e bussola	Complete door hinge pin	Groupe charnière et douille
00002160	Distanziatore pannello	Panel fixing screw	Boulon panneau
00003600	Raccordo angolo	Waste connector elbow	Raccord angle
00003750	Tubetto pressostato	Pressure stat tube	Tube pressostat
00005770	Targhetta brillantante - 00005750	Rincaid adjustment hole logo	Panneau rincage - 00005750
00007000	Cestello quadro 60 16 posti - X098E006	16 position plate model 60	Panier carré 60 16 pl. -X098E006
00007300	Cestello tondo 60 15 posti - X097B005	15 position round plate rack for model 55	Panier rond 60 15 pl. - X097B005
00007400	Cestello tondo 55 - X097B005	Round glass/cup rack for model 55	Panier rond 55 - X097B005
00010720	Tirante portella dx 48 - 48E - 55 - 60	Right hand door stay for model 48/48E/55/60	Entretoise porte droite - 48 - 48E - 55 - 60
00010730	Tirante portella sx 48 - 48E - 55 - 60	Left hand door stay for model 48/48E/55/60	Entretoise porte gauche 48 - 48E - 55 - 60
00011028	Blocchetto di chiusura posteriore	Sprung door catch	Bloc de fermeture posterieur
00011040	Blocchetto di chiusura anteriore	Clasp door catch	Bloc de fermeture anterieure
00011100	Gruppo microporta	Door micro switch assembly	Groupe microporte
00017123	Anello di spallamento	Door hinge pin sleeve	Anneau
00200500	Filtro 42E - 48E	Wash pump filter for model 42E/48E	Filtre 42E - 48E
00200550	Filtro 42 - 48 - 55 - 60	Wash pump filter for model 42/48/55/60	Filtre 42 - 48 - 55 - 60
00202120	Gruppo vaschetta - tappo	Wash / drain sump assembly	Groupe cuve
00202132	Tappo troppopieno	Drain plug for gravity drain	Bonde
00202136	Tappo troppopieno per pompa scarico	Drain plug for drain pump	Bonde pour pompe vidange
00202150	Guarnizione vaschetta	Wash/drain sump gasket	Joint fond cuve
00203089	Resistenza vasca 2700W 230V	Wash tank element 2700W 230V	Resistance cuve 2700W 230V
00205225	Fondo 42 - 42E	Base plate for model 42/42E	Fond 42 - 42E
00205306	Fondo 48 - 48E	Base plate for model 48/48E	Fond 48 - 48E
00205406	Fondo 55 - 60	Base plate for model 55/60	Fond 55 - 60
00205530	Maniglia	Door handle	Man
00205630	Coppia guide cestello 42 - 42E	Basket runner for model 42 - 42E	Couple guide panier 42 - 42E
00205640	Coppia guide cestello 48 - 48E	Basket runner for model 48 - 48E	Couple guide panier 48 - 48E
00205650	Coppia guide cestello 55 - 60	Basket runner for model 55 - 60	Couple guide panier 55 - 60
00205750	Campana pressostato	Air receiving box	Cloche pressostat
00206645	Telaio portacestello tondo 42	Drip tray for 42 basket	Chassis porte panier rond 42
00206650	Telaio portacestello tondo 48	Drip tray for 48 basket	Chassis porte panier rond 48
00206655	Telaio portacestello tondo 55 - 60	Drip tray for 55/60 basket	Chassis porte panier rond 55 - 60
00206711	Cestello quadro 42 - 002067000	Glass/cup rack for model SQ42	Panier carré 42 - 002067000
00206712	Cestello quadro 48 - 002067000	Glass/cup rack for model SQ48	Panier carré 48 - 002067000
00206713	Cestello quadro 55 - 60 - 002067000	Glass/cup rack for model SQ48	Panier carré 55 - 60 - 002067000
00206717	Cestello quadro 48 12 posti - 002067000	12 position plate rack for model SQ48	Panier carré 48 12 pl. - 002067000
00206719	Cestello 48 bicchieri inclinati - 00206700	Inclined glass/cup rack for model SQ48	Panier 48 verre incliné - 00206700
00206720	Cestello 55-60 bicchieri inclinati - 00206700	Inclined glass/cup rack for model SQ55/60	Panier 55 - 60 verre incliné - 00206700
00206721	Portaposate	Cutlery rack	Godet
00206731	Cestello tondo 42 - 00206730	Round glass/cup rack for model 42	Panier rond 42 - 00206730
00206732	Cestello tondo 48 - 00206730	Round glass/cup rack for model 48	Panier rond 48 - 00206730
00206751	Porta piattini 00206751	Saucer insert rack	Porte soucoupe
00206960	Piedino	Machine foot	Pied
00207007	Targa maniglia - 00207000	Door handle logo	Bandeau panneau - 00207000
00210100	Cassone 42 - 42E	Machine case for model 42/42E	Caisson 42 - 42E
00210120	Cassone 48 - 48E	Machine case for model 48/48E	Caisson 48 - 48E
00210140	Cassone 55 - 60	Machine case for model 55/60	Caisson 55 - 60
00210160	Fascia telaio 42 - 42E	Side panel for model 42/42E	Bandeau chassis 42 - 42E
00210170	Pannello 42 - 42E	Facia panel for model 42/42E	Panneau 42 - 42E
00210180	Fascia telaio 48 - 48E	Facia panel for model 48/48E	Bandeau chassis 48 - 48E
00210190	Pannello 48 - 48E	Side panel for model 48/48E	Panneau 48 - 48E
00210200	Fascia telaio 55 - 60	Facia panel for model 55/60	Bandeau chassis 55 - 60
00210210	Pannello 55 - 60	Side panel for model 55/60	Panneau 55 - 60
00210220	Schienale 42 - 42E	Back panel for model 42/42E	Arrière 42 - 42E
00210230	Schienale 48 - 48E	Back panel for model 48/48E	Arrière 48 - 48E
00210240	Schienale 55 - 60	Back panel for model 55/60	Arrière 55 - 60
00210255	Coperchio quadro elettrico 42 - 42E	Top panel for model 42/42E	Couvercle tableau électrique 42 - 42E
00210285	Coperchio quadro elettrico 48 - 48E	Top panel for model 48/48E	Couvercle tableau électrique 48 - 48E





nuova **elcamo** S.R.L.

3ip Общепит  
LAVABICCHIERI  
42-48-55-60-42E-48E  
vsezip.ru

TAV. 1

+7(812)987-08-81

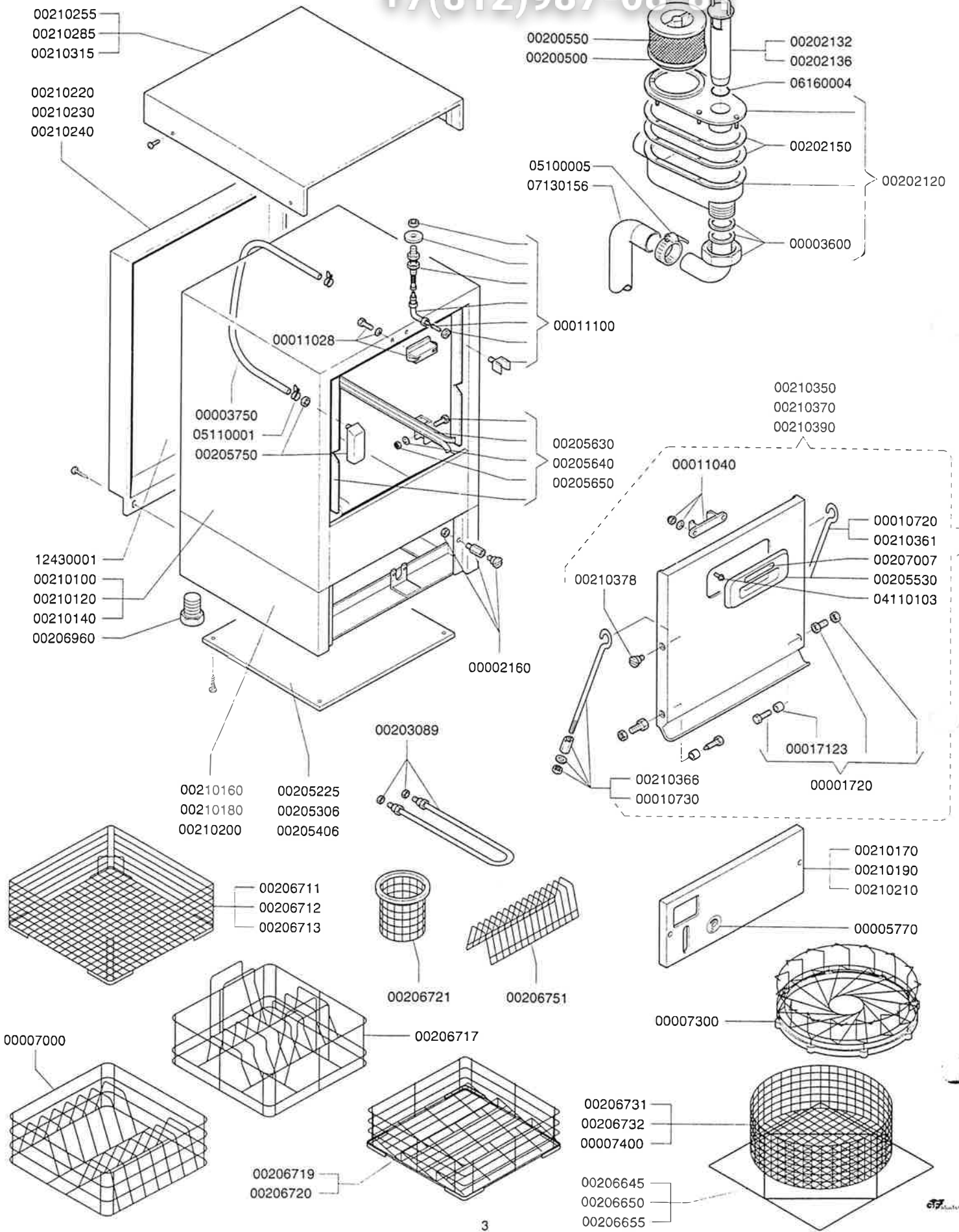





3ip Общепит  
**LAVABICCHIERI**  
**42-48-55-60-42E-48E**  
 vsezip.ru

TAV. 2

+7(812)987-08-81

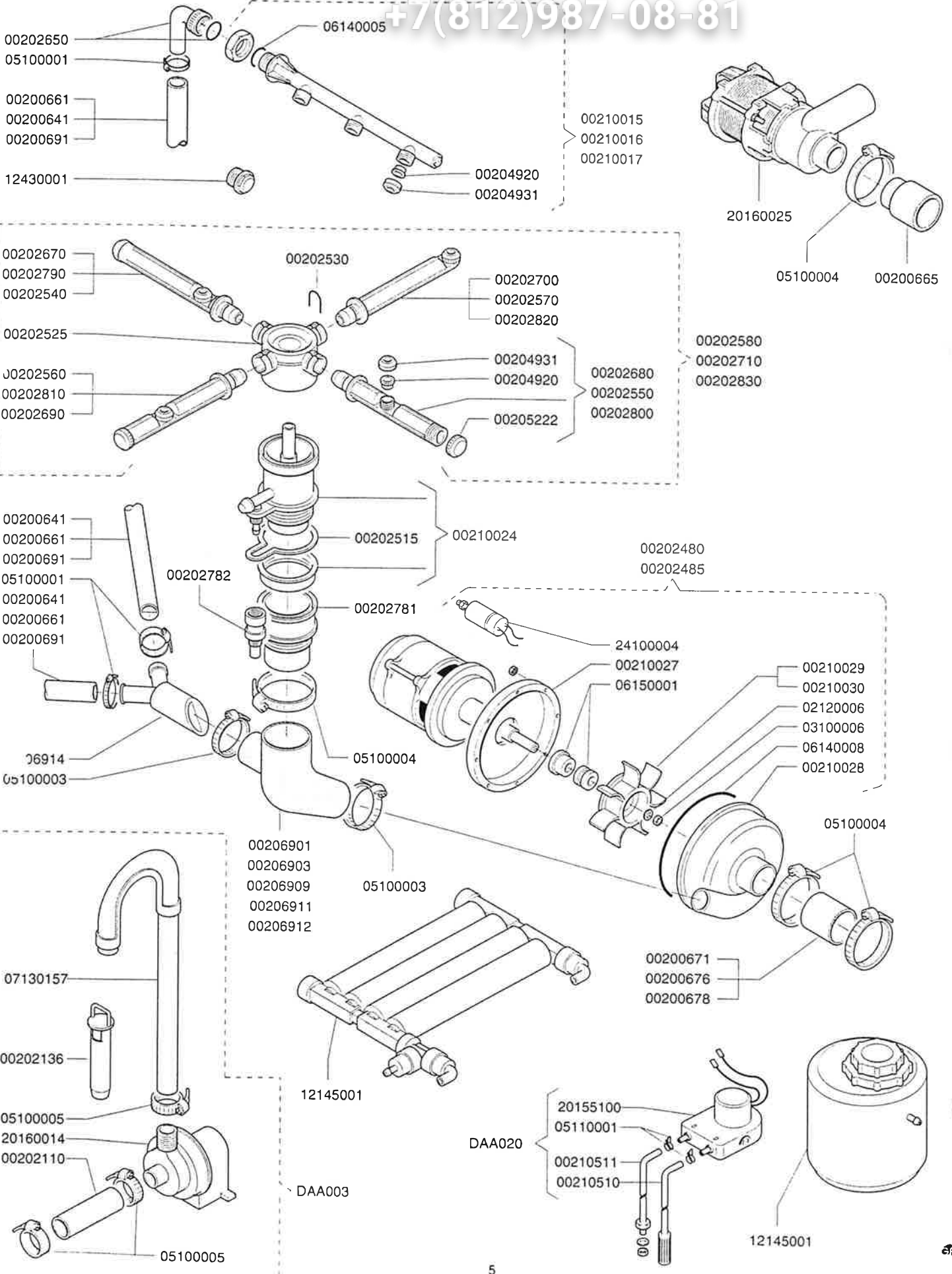

**DISTINTA PER RICAMBIO** (Per l'ordinazione riferire sempre il tipo/modello e l'anno di fabbricazione)  
**SPARE PARTS LIST** (When ordering please always indicate type/model and production year)  
**LISTE PIÈCES DÉTACHÉES** (En cas de commande indiquer le modèle et l'année de fabrication)

TAV.

**2**

COD.	DENOMINAZIONE	DENOMINATION	DÉNOMINATION
00200641	Tubo gomma LG=670	Rubber wash pipe length=670	Tube LG=670
00200661	Tubo gomma LG=540	Rubber wash pipe length=540	Tube LG=540
00200671	Tubo aspirante LG=65 - 48	Wash pump suction tube length=65 for model 48	Tube aspirant LG=65 - 48
00200676	Tubo aspirante LG=50 - 42	Wash pump suction tube length=50 for model 42	Tube aspirant LG=50 - 42
00200678	Tubo aspirante LG=100	Wash pump suction tube length=100 for model 55	Tube aspirant LG=100
00200691	Tubo gomma LG=770 - 55	Rubber wash pipe length=770	Tube LG=770 - 55
00202110	Tubo raccordo scarico LG=280	Drain pump connecting tube length=280	Tube raccord vidange LG=280
00202480	Elettropompa W300 V220-240	Wash pump complete 300W 220-240V	Pompe W300 V220-240
00202485	Elettropompa W400 V220-240	Wash pump complete 400W 220-240V	Pompe W400 V220-240
00202515	Guarnizione collettore inferiore	Lower wash fixed boss gasket	Joint collecteur inferieure
00202525	Collettore rotante lavaggio	Rotating wash boss	Collecteur rotatif lavage
00202530	Graffetta collettore lavaggio	Wash arm fixing clip	Agrafe collecteur lavage
00202540	Braccio lavaggio corto 48 - 48E	Wash arm with short jet for model 48	Bras lavage court 48 - 48E
00202550	Braccio lavaggio medio corto 48 - 48E	Wash arm with medium short jet for model 48	Bras lavage moyen court 48 - 48E
00202560	Braccio lavaggio medio lungo 48 - 48E	Wash arm with medium jet for model 48	Bras lavage moye long 48 - 48E
00202570	Braccio lavaggio lungo 48 - 48E	Wash arm with long jet for model 48	Bras lavage long 48 - 48E
00202580	Gruppo lavaggio completo 48 - 48E	Complete wash arm set including rotating boss for model 48	Groupe lavage complet 48 - 48E
00202650	Gomito	Top wash connecting elbow	Coude
00202670	Braccio lavaggio corto 42 - 42E	Wash arm with short jet for model 42	Bras lavage court 42 - 42E
00202680	Braccio lavaggio medio corto 42 - 42E	Wash arm with medium short jet for model 42	Bras lavage moyen court 42 - 42E
00202690	Braccio lavaggio medio lungo 42 - 42E	Wash arm with medium jet for model 42	Bras lavage moyen long 42 - 42E
00202700	Braccio lavaggio lungo 42 - 42E	Wash arm with long jet for model 42	Bras lavage long 42 - 42E
00202710	Gruppo lavaggio completo 42 - 42E	Complete wash arm set including rotating boss for model 42	Groupe lavage complet 42 - 42E
00202781	Prolunga lavaggio 55 - 60	Wash boss extension for model 55	Rallonge lavage 55 - 60
00202782	Prolunga risciacquo 55 - 60	Rinse boss extension for model 55	Rallonge rincage 55 - 60
00202790	Braccio lavaggio corto 55 - 60	Wash arm with short jet for model 55	Bras lavage court 55 - 60
00202800	Braccio lavaggio medio corto 55 - 60	Wash arm with medium short jet for model 55	Bras lavage moyen court 55 - 60
00202810	Braccio lavaggio medio lungo 55 - 60	Wash arm with medium jet for model 55	Bras lavage moyen long 55 - 60
00202820	Braccio lavaggio lungo 55	Wash arm with long jet for model 55	Bras lavage long 55
00202830	Gruppo lavaggio completo 55 - 60	Complete wash arm set including rotating boss for model 55	Groupe lavage complet 55 - 60
00204920	Anima ugello lavaggio	Wash jet insert	Corps jet lavage
00204931	Ugello lavaggio	Wash jet	Jet lavage
00205222	Tappo di testa	Wash arm end cap	Couvercle
00206901	Manicotto 42E	Wash pump outlet for model 42E	Manchon 42E
00206903	Manicotto 48E	Wash pump outlet for model 48E	Manchon 48E
00206909	Manicotto 55 - 60	Wash pump outlet for model 55	Manchon 55 - 60
00206911	Manicotto 42	Wash pump outlet for model 42	Manchon 42
00206912	Manicotto 48	Wash pump outlet for model 48	Manchon 48
00206914	Raccordo a tre vie	Wash three way conector	Raccord a voise
00210015	Braccio di lavaggio superiore 42	Top wash arm for model 42	Bras lavage superieure 42
00210016	Braccio di lavaggio superiore 48	Top wash arm for model 48	Bras lavage superieure 48
00210017	Braccio di lavaggio superiore 55	Top wash arm for model 55	Bras lavage superieure 55
00210024	Collettore fisso gruppo inferiore	Bottom fixed wash boss	Collecteur fixe groupe inferieure
00210027	Corpo pompa	Rear pump impellor case	Corps pompe
00210028	Coperchio pompa	Pump impellor case	Couvercle pompe
00210029	Girante HZ50	Impellor for 50HZ electrical supply	Turbine HZ50
00210030	Girante HZ60	Impellor for 60HZ electrical supply	Turbine HZ60
00210510	Tubo silicone 4x7 LG=1800	Detergent pump suction tube length=1800	Tube silicone 4x7 LG=1800
00210511	Tubo silicone 4x7 LG=1200	Detergent pump delivery tube length=1200	Tube silicone 4x7 LG=1200
02120006	Rosetta inox M6 UNI 6592	Stainless steel washer M6 UNI 6592	Rondelle M6 UNI 6592
03100006	Dado es inox M6 UNI 5588	Impellor fixing nut M6 UNI 5588	Écrou inox M6 UNI 5588
05100001	Fascetta D=15-24	Jubilee clip DIA=15-24	Collier D= 15 - 24
05100003	Fascetta D=44-56	Jubilee clip DIA=44-56	Collier D= 44 - 56
05100004	Fascetta D=50-65	Jubilee clip DIA=50-65	Collier D= 50 - 65
05110001	Fascetta D=7	Jubilee clip DIA=7	Collier D= 7
06140005	Anello OR 127=2,62x20,24	OR ring 127=2.62-20.24	Anneau OR 127= 2.62x20.24
06140008	Anello OR =1,78x119	Impellor case OR ring=1.78-119	Anneau OR= 1.78x119
06150001	Tenuta meccanica D=12	Mechanicall seal DIA=12	Joint étanchéité D=12



nuova  
**elframo**  
SRL

3ip Общепит  
**LAVABICCHIERI**  
42-48-55-60-42E-48E  
vsezip.ru

**TAV. 2**

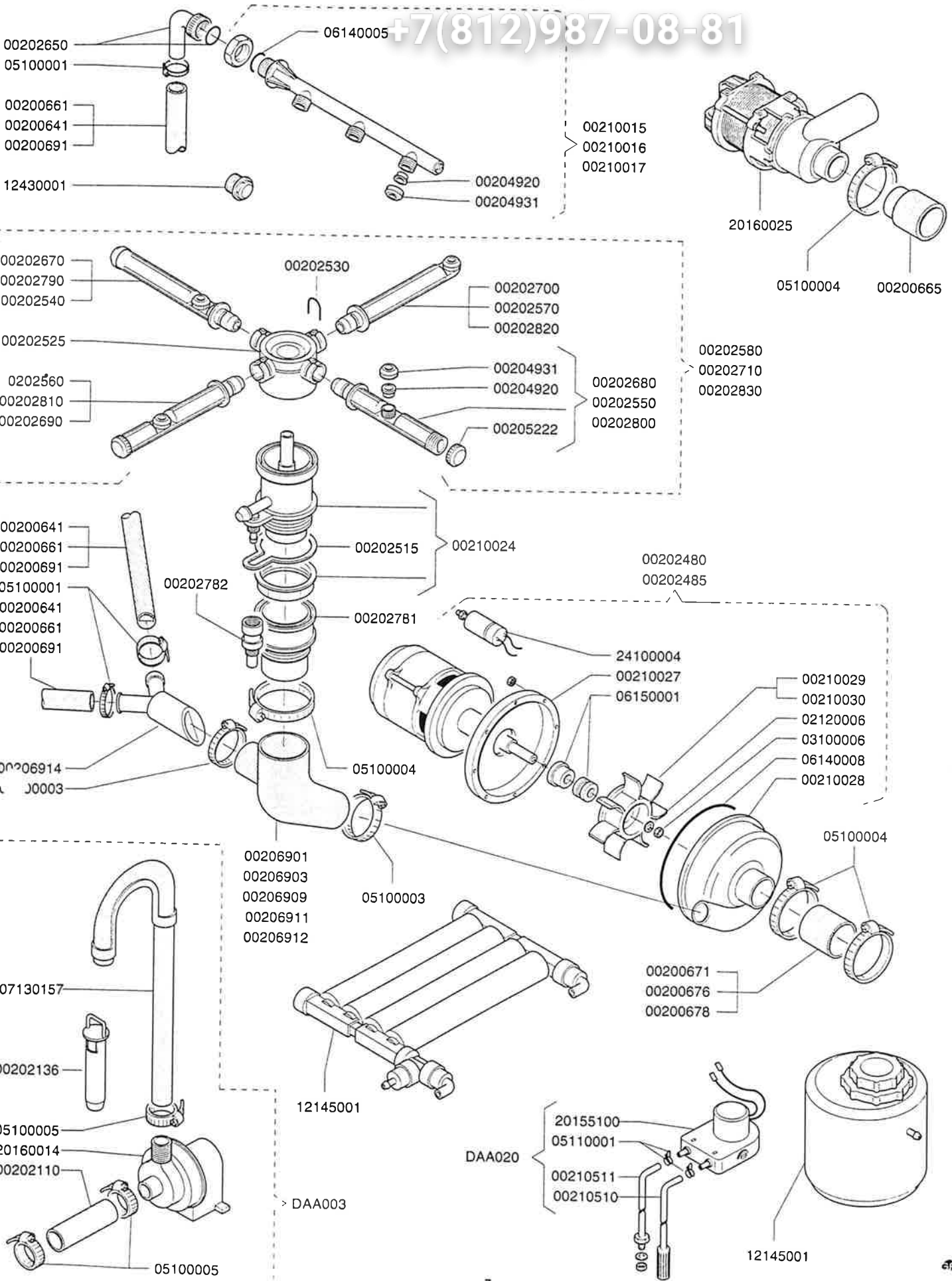







nuova  
**elctramo**  
S.p.A.

3ИЛАВБЮСІЕРТ  
42-48-55-60-42E-48E  
vsezip.ru

TAV. 3

+7(812)987-08-81

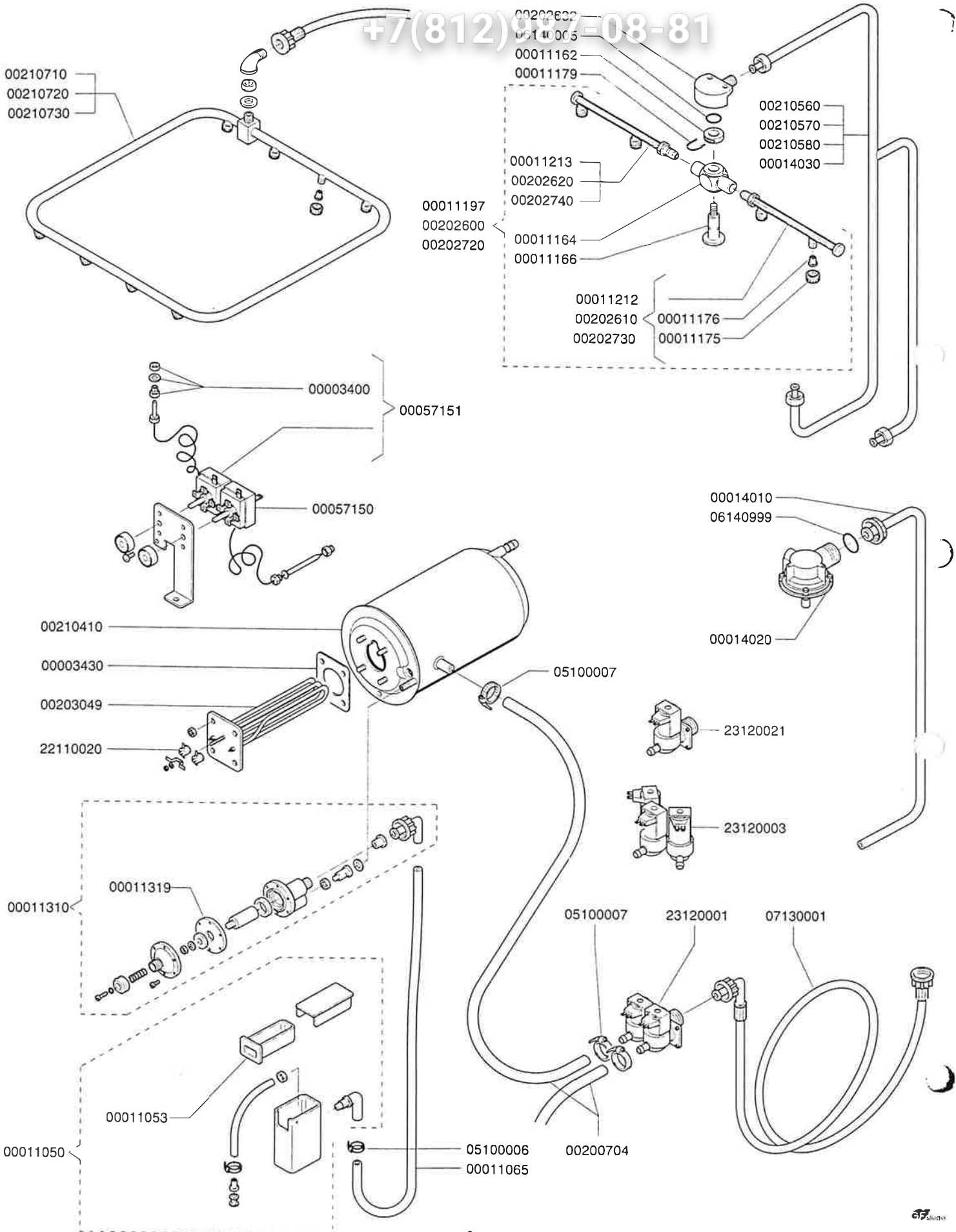

DISTINTA PER RICAMBIO (Per l'ordinazione riferire sempre il tipo/modello e l'anno di fabbricazione)  
**SPARE PARTS LIST** (When ordering pls always indicate type/model and production year)  
**LISTE PIÉCES DÉTACHÉES** (En cas de commande indiquer le modèle et l'an de fabrication)

TAV.  
**3**

COD.	DENOMINAZIONE	DENOMINATION	DÉNOMINATION
00003400	Bussola per termostato	Thermostat phial fixing gland	Douille
00003430	Guarnizione resistenza	Rinse boiler element gasket	Joint resistance
00011050	Vaschetta brillantante bassa	Rinsaid container complete	Bac
00011053	Cassetto vaschetta	Rinsaid container drawer	Tiroir
00011065	Tubo vaschetta brillantante	Rinsaid conection tube	Tube contenant rincage
00011162	Piattello	Retor. Rinse spindle washer	Eclou
00011164	Collettore rotante risciacquo	Centrall rinse boss	Collecteur rincage rotatif
00011166	Perno di bloccaggio	Centrall rinse spindle	Boulon
00011175	Ugello di risciacquo	Rinse jet	Jet rincage
00011176	Anima ugello di risciacquo	Rinse jet insert	Corps jets rincage
00011179	Graffetta piattello	Washer clip	Agrafe ecrou
00011197	Gruppo risciacquo completo 55 - 60	Complete rinse arm for model 55/60	Groupe rincage complet 55 - 60
00011212	Braccio risciacquo 1° inclinato 55 - 60	Rinse arm with inclined jet for model 55/60	Bras rincage 1° incliné 55 - 60
00011213	Braccio risciacquo 1° diritto 55 - 60	Rinse arm with straight jet for model 55/60	Bras rincage 1° direct 55 - 60
00011310	Pompetta brillantante	Complete rinsaid pump	Pompe rincage
00011319	Membrana pompa brillantante	Rinsaid pump diaphragm	Membrane produit rincage
00014010	Colonna lavaggio 60	Top wash pipe for model 60	Colonne lavage 60
00014020	Collettore superiore 1" ¼ 60	Fixed top wash boss	Collecteur superieure 1" ¼ 60
00014030	Colonna risciacquo 60	Rinse supply pipe for model 60	Colonne rincage 60
00057150	Termostato reg. 0-90°	Rinse thermostat 0-90°	Thermostat reg. 0-90°
00057151	Termostato fisso	Wash tank thermostat	Thermostat fixe
00200704	Tubo D. 12x19	Tube DIA=12/19	Tube D. 12x19
00202600	Gruppo risciacquo completo 48 - 48E	Complete rinse arm for model 48/48E	Groupe rincage complet 48 - 48E
00202610	Braccio risciacquo 1° inclinato 48 - 48E	Rinse arm with inclined jet for model 48/48E	Bras rincage 1° incliné 48 - 48E
00202620	Braccio diritto risciacquo 48 - 48E	Rinse arm with straight jet for model 48/48E	Bras rincage droit 48 - 48E
00202632	Supporto collettore rotante risciacquo	Fixed top rinse boss	Support collecteur rincage rotatif
00202720	Gruppo risciacquo completo 42 - 42E	Complete rinse arm for model 42/42E	Groupe rincage complet 42 - 42E
00202730	Braccio risciacquo 1° inclinato 42 - 42E	Rinse arm with inclined jet for model 42/42E	Bras rincage 1° incline 42 - 42E
00202740	Braccio risciacquo 1° diritto 42 - 42E	Rinse arm with straight jet for model 42/42E	Bras rincage 1° droit 42 - 42E
00203049	Resistenza boiler 3000W 230V	Rinse boiler element 3000W 230V	Resistance surchauffeur 3000W 230V
00210410	Boiler montato completo	Rinse boiler	Surchauffeur complet
00210560	Colonna risciacquo 42	Rinse pipe for model 42	Colonne rincage 42
00210570	Colonna risciacquo 48	Rinse pipe for model 48	Colonne rincage 48
00210580	Colonna risciacquo 55	Rinse pipe for model 55	Colonne rincage 55
00210711	Circuito raffreddamento 42	Top wash pipe for model 42	Circuit refroidissement 42
00210721	Circuito raffreddamento 48	Top wash pipe for model 48	Circuit refroidissement 48
00210731	Circuito raffreddamento 55	Top wash pipe for model 55	Circuit refroidissement 55
05100006	Fascetta D. 12	Jubilee clip DIA=12	Collier D.12
05100007	Fascetta D=13-20	Jubilee clip DIA=13-20	Collier D= 13 - 20
06140005	OR 127	OR ring 127	OR 127
06140999	OR 136	OR ring 136	OR 136
07130001	Tubo carico	Inlet hose	Tube remplissage
22110020	Termostato sicurezza boiler	Rinse boiler safety thermostat	Thermostat securite surchauffeur
23120001	Elettrovalvola 2 vie 220V	Inlet solenoid two outlets 220V	Electrovanne 2 voies 220V
23120003	Elettrovalvola rigenerazione 3 vie 220V	Inlet solenoid three outlets 220V	Electrovanne regeneration 3 voies 220V
23120021	Elettrovalvola 1 via c/riduttore 10lt.	Inlet solenoid one outlet	Electrovanne 1 voie c/reducteur 10lt.
00206754	Ingresso gas		



00210250

00014050

00210230

00210180

00210310

00210490

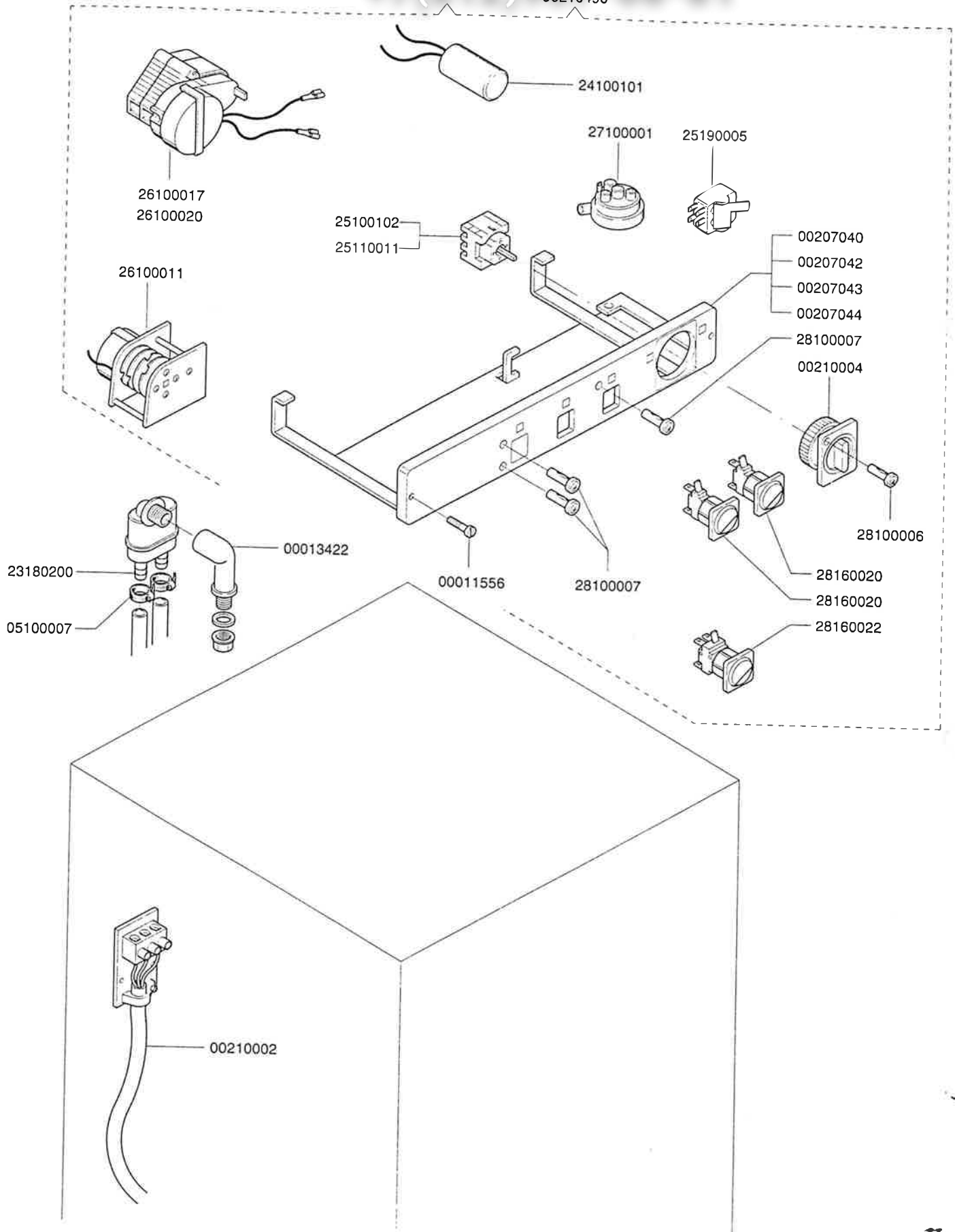





**Зип Общепит**

**vsezip.ru**

**+7(812)987-08-81**