

**Зип Общепит**

**DESPIECE TECNICO**

**vsezip.ru**

**+7(812)987-08-81**

**Lavavajillas arrastre de cinta  
Lave-vaisselle entrainement à bande  
Belt conveyor dishwasher  
Transportband Geschirrspüler  
Lavastoviglie con avanzamento a nastro**

**Modelos:**

**FI-2700**

**FI-4000**

**FI-6000**

**ECO-2700**

**ECO-4000**

**ECO-6000**

*Julio 2004 July*



**Fagor Industrial**

Зип Общежит

vsezip.ru

+7(812)987-08181

N plano  
C-1545

Firma

Fecha  
7-2004

Aparato  
LAVAVAJILLAS DE CINTA  
MODULO DE ENTRADA

Lamina  
1

Fagor Industrial S. Coop.  
Onate

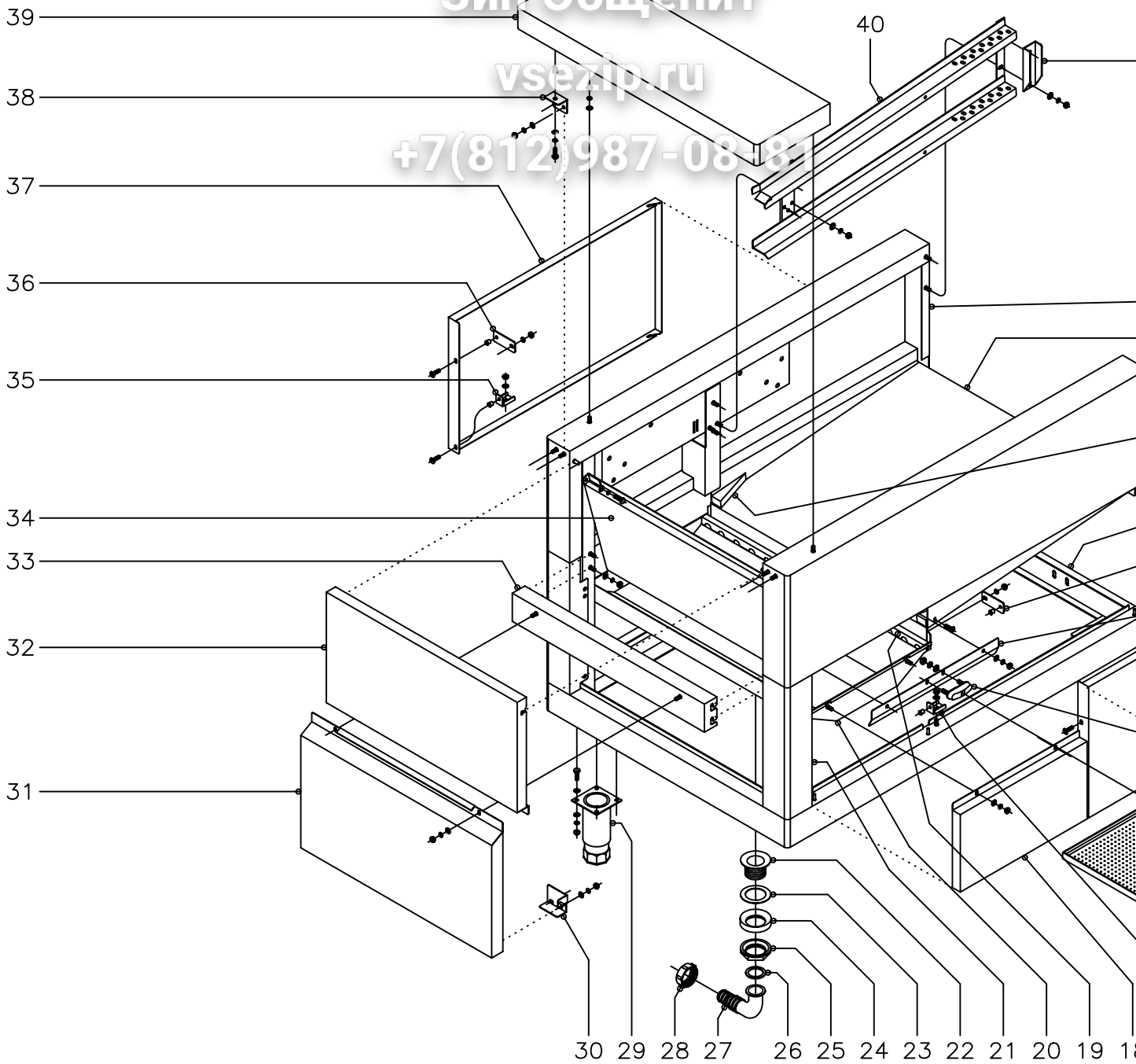

# Зип Общепит

vsezip.ru

ZONA

MODULO DE ENT

MOD.

LAVAVAJILLAS DE CINTA

+7(812)987-08-81

| ITEM | CODIGO  | DENOMINACION                 | TEXTO                        | 2700 I | 2700 D | 4000 I | 4000 D |
|------|---------|------------------------------|------------------------------|--------|--------|--------|--------|
| 1    | Z510408 | Entrada izquierda soldada    | Welded left inlet            | 1      | 1      | 1      | 1      |
| 2    | Z510419 | Fondo entrada completa       | Complete inlet back          | 1      | 1      | 1      | 1      |
| 3    | Z510415 | Entrada derecha soldada      | Welded right inlet           | 1      | 1      | 1      | 1      |
| 4    | Z510435 | Cantонера recogedor          | Pick up corner protector     | 2      | 2      | 2      | 2      |
|      | Q152004 | Tornillo aplastado M-5x13    | Screw M-5x13                 | 2      | 2      | 2      | 2      |
| 5    | Z510401 | Armazón entrada soldado      | Welded inlet framework       | 1      | 1      | 1      | 1      |
| 6    | Z512961 | Amarre superior panel        | Upper panel anchoring        | 1      | 1      | 1      | 1      |
|      | Q262040 | Arandela muelle A-6          | Spring washer A-6            | 1      | 1      | 1      | 1      |
|      | Q162040 | Tuerca hexagonal M-6         | Hexagonal nut M-6            | 1      | 1      | 1      | 1      |
|      | Q221342 | Remache hexagonal M-5        | Hexagonal rivet M-5          | 1      | 1      | 1      | 1      |
| 7    | Z512905 | Panel portamandos entrada    | Inlet control panel          | 1      | -      | 1      | -      |
| 7    | Z512906 | Panel portamandos entrada    | Inlet control panel          | -      | 1      | -      | 1      |
|      | Q152004 | Tornillo aplastado M-5x13    | Screw M-5x13                 | 2      | 2      | 2      | 2      |
| 8    | Z510472 | Protector inf. fugas entrada | Lower protector escape inlet | 2      | 2      | 2      | 2      |
|      | Q302022 | Arandela plana Ø16xØ6x1,2    | Flat washer Ø16xØ6x10.2      | 4      | 4      | 4      | 4      |
|      | Q262040 | Arandela muelle A-6          | Spring washer A-6            | 4      | 4      | 4      | 4      |
|      | Q162040 | Tuerca hexagonal M-6         | Hexagonal nut M-6            | 4      | 4      | 4      | 4      |
| 9    | Z513006 | Etiqueta circular amarillo   | Round yellow label           | 1      | 1      | 1      | 1      |
| 10   | Z513005 | Interruptor de seta rojo     | Round mushroom switch        | 1      | 1      | 1      | 1      |
| 11   | Z513004 | Pulsador rojo completo       | Complete red push button     | 1      | 1      | 1      | 1      |
| 12   | Z513003 | Pulsador verde completo      | Complete green push button   | 1      | 1      | 1      | 1      |
| 13   | Z200607 | Conjunto cierre              | Closure set                  | 2      | 2      | 2      | 2      |
|      | Q302022 | Arandela plana Ø16xØ6x1,2    | Flat washer Ø16xØ6x10.2      | 4      | 4      | 4      | 4      |
|      | Q262040 | Arandela muelle A-6          | Spring washer A-6            | 4      | 4      | 4      | 4      |
|      | Q162040 | Tuerca hexagonal M-6         | Hexagonal nut M-6            | 4      | 4      | 4      | 4      |
| 14   | Z200601 | Enganche cierre              | Closure hook                 | 2      | 2      | 2      | 2      |
|      | Q221342 | Remache hexagonal M-5        | Hexagonal rivet M-5          | 1      | 1      | 1      | 1      |
| 15   | Z448703 | Asa                          | Handle                       | 2      | 2      | 2      | 2      |
|      | Q152004 | Tornillo aplastado M-5x13    | Screw M-5x13                 | 4      | 4      | 4      | 4      |

# Зип Общепит

vsezip.ru

ZONA

MODULO DE ENTRADA

LAVAVAJILLAS DE CINTA

+7(812)987-08-81

| ITEM | CODIGO  | DENOMINACION                   | TEXTO                        | 2700 I | 2700 D | 4000 I | 4000 D |
|------|---------|--------------------------------|------------------------------|--------|--------|--------|--------|
|      | Q221342 | Remache hexagonal M-5          | Hexagonal rivet M-5          | 4      | 4      | 4      | 4      |
| 16   | Z512915 | Panel superior recogedor comp. | Complete pick up upper panel | 2      | 2      | 2      | 2      |
| 17   | Z512962 | Sujeción inferior panel        | Lower panel fastening        | 1      | 1      | 1      | 1      |
|      | Q302022 | Arandela plana Ø16xØ6x1,2      | Flat washer Ø16xØ6x10.2      | 1      | 1      | 1      | 1      |
|      | Q162040 | Tuerca hexagonal M-6           | Hexagonal nut M-6            | 1      | 1      | 1      | 1      |
|      | Q221304 | Remache redondo M-5            | Round rivet M-5              | 1      | 1      | 1      | 1      |
| 18   | Z512918 | Panel inferior recogedor       | Pick up lower panel          | 2      | 2      | 2      | 2      |
|      | Q302022 | Arandela plana Ø16xØ6x1,2      | Flat washer Ø16xØ6x10.2      | 4      | 4      | 4      | 4      |
|      | Q262040 | Arandela muelle A-6            | Spring washer A-6            | 4      | 4      | 4      | 4      |
|      | Q162040 | Tuerca hexagonal M-6           | Hexagonal nut M-6            | 4      | 4      | 4      | 4      |
| 19   | Z510434 | Guía bandeja recogedor         | Pick up tray guide           | 2      | 2      | 2      | 2      |
|      | Q152004 | Tornillo aplastado M-5x13      | Screw M-5x13                 | 2      | 2      | 2      | 2      |
| 20   | Z510431 | Fondo recogedor soldado        | Back welded pick up          | 1      | 1      | 1      | 1      |
|      | Q302022 | Arandela plana Ø16xØ6x1,2      | Flat washer Ø16xØ6x10.2      | 4      | 4      | 4      | 4      |
|      | Q262040 | Arandela muelle A-6            | Spring washer A-6            | 4      | 4      | 4      | 4      |
|      | Q162040 | Tuerca hexagonal M-6           | Hexagonal nut M-6            | 4      | 4      | 4      | 4      |
|      | Q412004 | Remache monobolt Ø4,8          | Monobolt rivet Ø40.8         | 4      | 4      | 4      | 4      |
| 21   | Z510420 | Cantonera                      | Corner protector             | 2      | 2      | 2      | 2      |
|      | Q412004 | Remache monobolt Ø4,8          | Monobolt rivet Ø40.8         | 12     | 12     | 12     | 12     |
| 22   | Z102104 | Válvula desagüe                | Drainage valve               | 1      | 1      | 1      | 1      |
| 23   | Q307009 | Arandela junta Ø70xØ48x1,5     | Joint washer Ø70xØ48x10.5    | 1      | 1      | 1      | 1      |
| 24   | Q307026 | Junta especial                 | Special joint                | 1      | 1      | 1      | 1      |
| 25   | Z702101 | Tuerca rosca 1 1/2"            | Screw thread 1 1/2"          | 1      | 1      | 1      | 1      |
| 26   | Q307027 | Arandela junta Ø45xØ35x2       | Joint washer Ø45xØ35x2       | 1      | 1      | 1      | 1      |
| 27   | Z602101 | Codo desagüe                   | Drainage elbow               | 1      | 1      | 1      | 1      |
| 28   | Z602102 | Tuerca                         | Nut                          | 1      | 1      | 1      | 1      |
| 29   | X260151 | Pata regulable                 | Adjustable leg               | 4      | 4      | 4      | 4      |
|      | Q012043 | Tornillo hexagonal M-6x20      | Hexagonal screw M-6x20       | 16     | 16     | 16     | 16     |
|      | Q302022 | Arandela plana Ø16xØ6x1,2      | Flat washer Ø16xØ6x10.2      | 32     | 32     | 32     | 32     |

# Зип Общепит

vsezip.ru

ZONA

MODULO DE ENTRADA

MOD.

LAVAVAJILLAS DE CINTA

+7(812)987-08-81

| ITEM | CODIGO  | DENOMINACION                      | TEXTO                         | 2700 I | 2700 D | 4000 I | 4000 D |
|------|---------|-----------------------------------|-------------------------------|--------|--------|--------|--------|
|      | Q262040 | Arandela muelle A-6               | Spring washer A-6             | 16     | 16     | 16     | 16     |
|      | Q162040 | Tuerca hexagonal M-6              | Hexagonal nut M-6             | 16     | 16     | 16     | 16     |
| 30   | Z512956 | Soporte giro derecho completo     | Complete right turn support   | 1      | 1      | 1      | 1      |
| s/n  | Z512958 | Soporte giro izquierdo completo   | Complete left turn support    | 1      | 1      | 1      | 1      |
|      | Q302022 | Arandela plana Ø16xØ6x1,2         | Flat washer Ø16xØ6x10.2       | 4      | 4      | 4      | 4      |
|      | Q262040 | Arandela muelle A-6               | Spring washer A-6             | 4      | 4      | 4      | 4      |
|      | Q162040 | Tuerca hexagonal M-6              | Hexagonal nut M-6             | 4      | 4      | 4      | 4      |
| 31   | Z512919 | Panel lateral inferior completo   | Complete lower side panel     | 1      | 1      | 1      | 1      |
|      | Q302022 | Arandela plana Ø16xØ6x1,2         | Flat washer Ø16xØ6x10.2       | 2      | 2      | 2      | 2      |
|      | Q262040 | Arandela muelle A-6               | Spring washer A-6             | 2      | 2      | 2      | 2      |
|      | Q162040 | Tuerca hexagonal M-6              | Hexagonal nut M-6             | 2      | 2      | 2      | 2      |
| 32   | Z512921 | Panel lateral superior            | Upper side panel              | 1      | 1      | 1      | 1      |
| 33   | Z510413 | Perfil tensor completo            | Complete profile turnbuckle   | 1      | 1      | 1      | 1      |
|      | Q302022 | Arandela plana Ø16xØ6x1,2         | Flat washer Ø16xØ6x10.2       | 4      | 4      | 4      | 4      |
|      | Q262040 | Arandela muelle A-6               | Spring washer A-6             | 4      | 4      | 4      | 4      |
|      | Q162040 | Tuerca hexagonal M-6              | Hexagonal nut M-6             | 4      | 4      | 4      | 4      |
| 34   | Z510473 | Protección superior fugas entrada | Upper protection escape inlet | 1      | 1      | 1      | 1      |
|      | Q012043 | Tornillo hexagonal M-6x20         | Hexagonal screw M-6x20        | 2      | 2      | 2      | 2      |
|      | Q302022 | Arandela plana Ø16xØ6x1,2         | Flat washer Ø16xØ6x10.2       | 2      | 2      | 2      | 2      |
|      | Q262040 | Arandela muelle A-6               | Spring washer A-6             | 2      | 2      | 2      | 2      |
| 35   | Z512962 | Sujeción inferior panel           | Lower panel fastening         | 1      | 1      | 1      | 1      |
|      | Q302022 | Arandela plana Ø16xØ6x1,2         | Flat washer Ø16xØ6x10.2       | 1      | 1      | 1      | 1      |
|      | Q162040 | Tuerca hexagonal M-6              | Hexagonal nut M-6             | 1      | 1      | 1      | 1      |
|      | Q221304 | Remache redondo M-5               | Round rivet M-5               | 1      | 1      | 1      | 1      |
| 36   | Z512961 | Amarre superior panel             | Upper panel anchoring         | 1      | 1      | 1      | 1      |
|      | Q262040 | Arandela muelle A-6               | Spring washer A-6             | 1      | 1      | 1      | 1      |
|      | Q162040 | Tuerca hexagonal M-6              | Hexagonal nut M-6             | 1      | 1      | 1      | 1      |
|      | Q221342 | Remache hexagonal M-5             | Hexagonal rivet M-5           | 1      | 1      | 1      | 1      |
| 37   | Z512911 | Panel posterior entrada izquierda | Left inlet rear panel         | 1      | -      | 1      | -      |

# Зип Общепит

vsezip.ru

ZONA

+7(812)987-08-81

|      | MOD.    | LAVAVAJILLAS DE CINTA           |                          | ZONA | MODULO DE ENTRADA |        |        |        |
|------|---------|---------------------------------|--------------------------|------|-------------------|--------|--------|--------|
| ITEM | CODIGO  | DENOMINACION                    | TEXTO                    |      | 2700 I            | 2700 D | 4000 I | 4000 D |
| s/n  | Z512909 | Panel posterior entrada derecha | Left inlet rear panel    |      | -                 | 1      | -      | 1      |
|      | Q152004 | Tornillo aplastado M-5x13       | Screw M-5x13             |      | 2                 | 2      | 2      | 2      |
| 38   | Z512963 | Soporte panel                   | Panel support            |      | 2                 | 2      | 2      | 2      |
|      | Q302022 | Arandela plana Ø16xØ6x1,2       | Flat washer Ø16xØ6x10.2  |      | 4                 | 4      | 4      | 4      |
|      | Q262040 | Arandela muelle A-6             | Spring washer A-6        |      | 4                 | 4      | 4      | 4      |
|      | Q162040 | Tuerca hexagonal M-6            | Hexagonal nut M-6        |      | 4                 | 4      | 4      | 4      |
| 39   | Z512935 | Tapa entrada                    | Inlet lid                |      | 1                 | 1      | 1      | 1      |
|      | Q221343 | Remache hexagonal M-6           | Hexagonal rivet M-6      |      | 2                 | 2      | 2      | 2      |
|      | Q302022 | Arandela plana Ø16xØ6x1,2       | Flat washer Ø16xØ6x10.2  |      | 4                 | 4      | 4      | 4      |
|      | Q262040 | Arandela muelle A-6             | Spring washer A-6        |      | 4                 | 4      | 4      | 4      |
|      | Q012043 | Tornillo hexagonal M-6x20       | Hexagonal screw M-6x20   |      | 2                 | 2      | 2      | 2      |
|      | Q162040 | Tuerca hexagonal M-6            | Hexagonal nut M-6        |      | 2                 | 2      | 2      | 2      |
| 40   | Z510421 | Guía entrada izquierda soldada  | Welded left inlet guide  |      | 1                 | 1      | 1      | 1      |
| s/n  | Z510427 | Guía entrada derecha soldada    | Welded right inlet guide |      | 1                 | 1      | 1      | 1      |
|      | Q302022 | Arandela plana Ø16xØ6x1,2       | Flat washer Ø16xØ6x10.2  |      | 8                 | 8      | 8      | 8      |
|      | Q262040 | Arandela muelle A-6             | Spring washer A-6        |      | 8                 | 8      | 8      | 8      |
|      | Q162040 | Tuerca hexagonal M-6            | Hexagonal nut M-6        |      | 8                 | 8      | 8      | 8      |
| 41   | Z510430 | Sujeción guía                   | Guide fastening          |      | 2                 | 2      | 2      | 2      |
|      | Q302022 | Arandela plana Ø16xØ6x1,2       | Flat washer Ø16xØ6x10.2  |      | 4                 | 4      | 4      | 4      |
|      | Q262040 | Arandela muelle A-6             | Spring washer A-6        |      | 4                 | 4      | 4      | 4      |
|      | Q162040 | Tuerca hexagonal M-6            | Hexagonal nut M-6        |      | 4                 | 4      | 4      | 4      |
|      |         |                                 |                          |      |                   |        |        |        |
|      |         |                                 |                          |      |                   |        |        |        |
|      |         |                                 |                          |      |                   |        |        |        |
|      |         |                                 |                          |      |                   |        |        |        |
|      |         |                                 |                          |      |                   |        |        |        |
|      |         |                                 |                          |      |                   |        |        |        |
|      |         |                                 |                          |      |                   |        |        |        |
|      |         |                                 |                          |      |                   |        |        |        |
|      |         |                                 |                          |      |                   |        |        |        |
|      |         |                                 |                          |      |                   |        |        |        |
|      |         |                                 |                          |      |                   |        |        |        |
|      |         |                                 |                          |      |                   |        |        |        |
|      |         |                                 |                          |      |                   |        |        |        |
|      |         |                                 |                          |      |                   |        |        |        |
|      |         |                                 |                          |      |                   |        |        |        |
|      |         |                                 |                          |      |                   |        |        |        |

Зип Общепит

vsezip.ru

+7(812)987-08-81

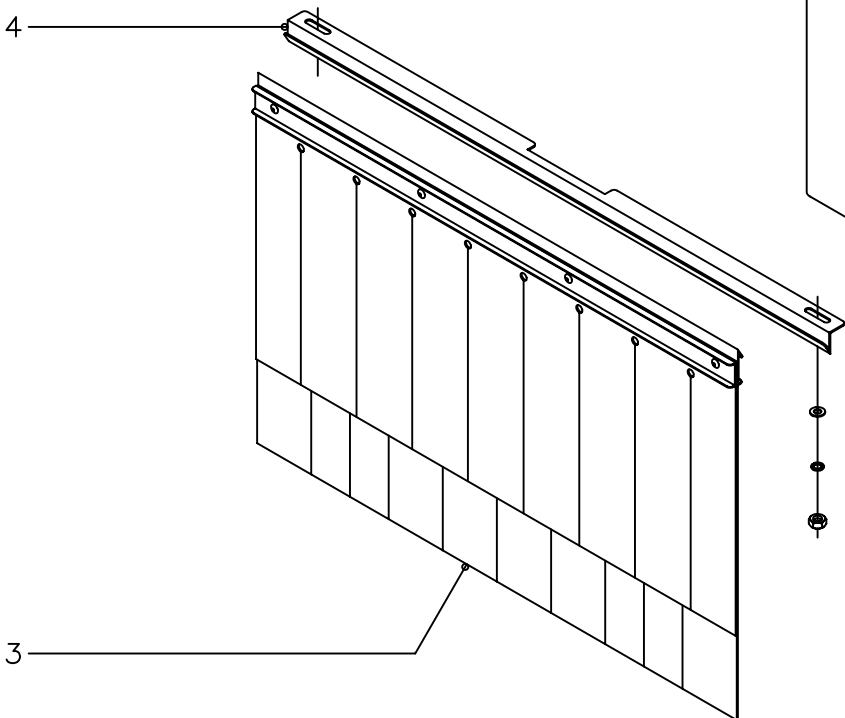
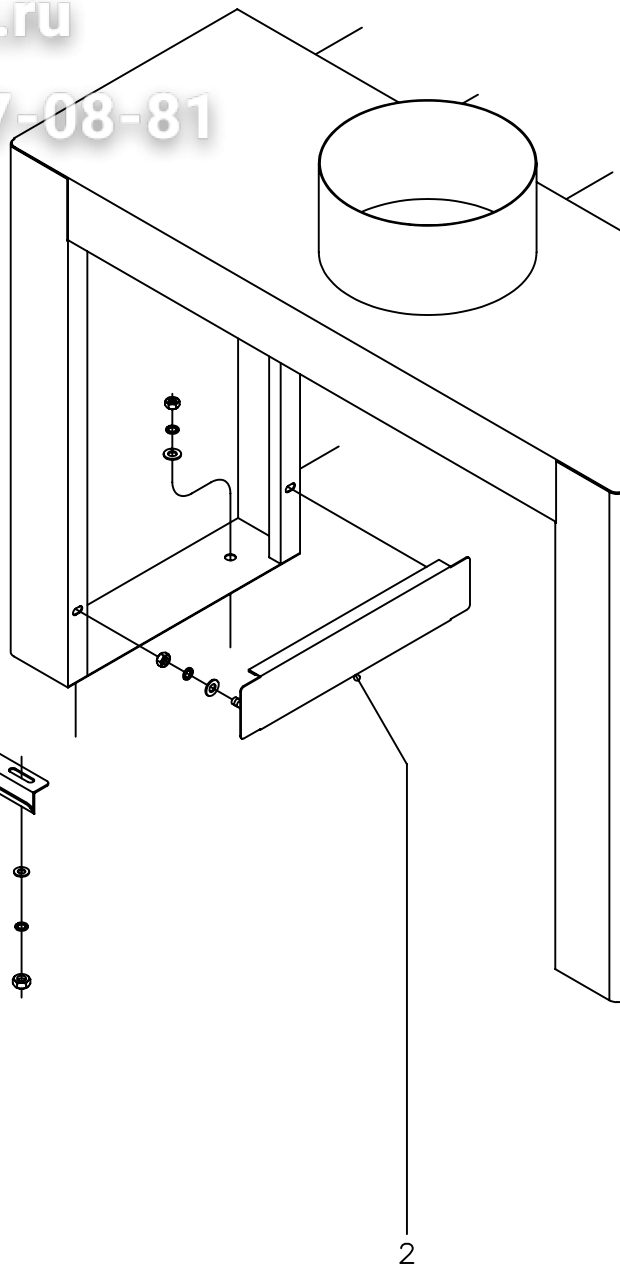

N plano  
C-1546

Firma

Fecha  
7-2004

Aparato  
LAVAVAJILLAS DE CINTA  
ASPIRADOR DE VAHOS

Lamina  
2

Fagor Industrial S. Coop.  
Omate  
**FAGOR**

| MOD. |         | LAVAVAJILLAS DE CINTA          |                                 | ZONA   |        | ASPIRADOR DE VA |        |  |  |
|------|---------|--------------------------------|---------------------------------|--------|--------|-----------------|--------|--|--|
| ITEM | CODIGO  | DENOMINACION                   | TEXTO                           | 2700 I | 2700 D | 4000 I          | 4000 D |  |  |
| 1    | Z516201 | Cubierta aspirador vahos comp. | Complete steam extractor cover  | 2      | 2      | 2               | 2      |  |  |
|      | Q012053 | Tornillo hexagonal M-8x20      | Hexagonal screw M-8x20          | 22     | 22     | 22              | 22     |  |  |
|      | Q232050 | Arandela plana A-8             | Flat washer A-8                 | 44     | 44     | 44              | 44     |  |  |
|      | Q262050 | Arandela muelle A-8            | Spring A-8 washer               | 22     | 22     | 22              | 22     |  |  |
|      | Q162050 | Tuerca hexagonal M-8           | Hexagonal nut M-8               | 22     | 22     | 22              | 22     |  |  |
|      | Q302022 | Arandela plana Ø16xØ6x1,2      | Flat washer Ø16xØ6x10.2         | 8      | 8      | 8               | 8      |  |  |
|      | Q262040 | Arandela muelle A-6            | Spring A-6 washer               | 8      | 8      | 8               | 8      |  |  |
|      | Q162040 | Tuerca hexagonal M-6           | Hexagonal nut M-6               | 8      | 8      | 8               | 8      |  |  |
| 2    | Z516204 | Protector entrada-salida comp. | Complete inlet-outlet protector | 4      | 4      | 4               | 4      |  |  |
|      | Q302022 | Arandela plana Ø16xØ6x1,2      | Flat washer Ø16xØ6x10.2         | 8      | 8      | 8               | 8      |  |  |
|      | Q262040 | Arandela muelle A-6            | Spring A-6 washer               | 8      | 8      | 8               | 8      |  |  |
|      | Q162040 | Tuerca hexagonal M-6           | Hexagonal nut M-6               | 8      | 8      | 8               | 8      |  |  |
| 3    | Z276419 | Cortina exterior completa      | Complete outer curtain          | 2      | 2      | 2               | 2      |  |  |
| 4    | Z510344 | Sujeción cortina               | Curtain fastening               | 2      | 2      | 2               | 2      |  |  |
|      | Q232040 | Arandela plana A-6             | Flat washer A-6                 | 4      | 4      | 4               | 4      |  |  |
|      | Q262040 | Arandela muelle A-6            | Spring A-6 washer               | 4      | 4      | 4               | 4      |  |  |
|      | Q162040 | Tuerca hexagonal M-6           | Hexagonal nut M-6               | 4      | 4      | 4               | 4      |  |  |
|      |         |                                |                                 |        |        |                 |        |  |  |
|      |         |                                |                                 |        |        |                 |        |  |  |
|      |         |                                |                                 |        |        |                 |        |  |  |
|      |         |                                |                                 |        |        |                 |        |  |  |
|      |         |                                |                                 |        |        |                 |        |  |  |
|      |         |                                |                                 |        |        |                 |        |  |  |
|      |         |                                |                                 |        |        |                 |        |  |  |
|      |         |                                |                                 |        |        |                 |        |  |  |
|      |         |                                |                                 |        |        |                 |        |  |  |
|      |         |                                |                                 |        |        |                 |        |  |  |



21 22

Зип Общепит

vsezip.ru

+7(812)987-08-81

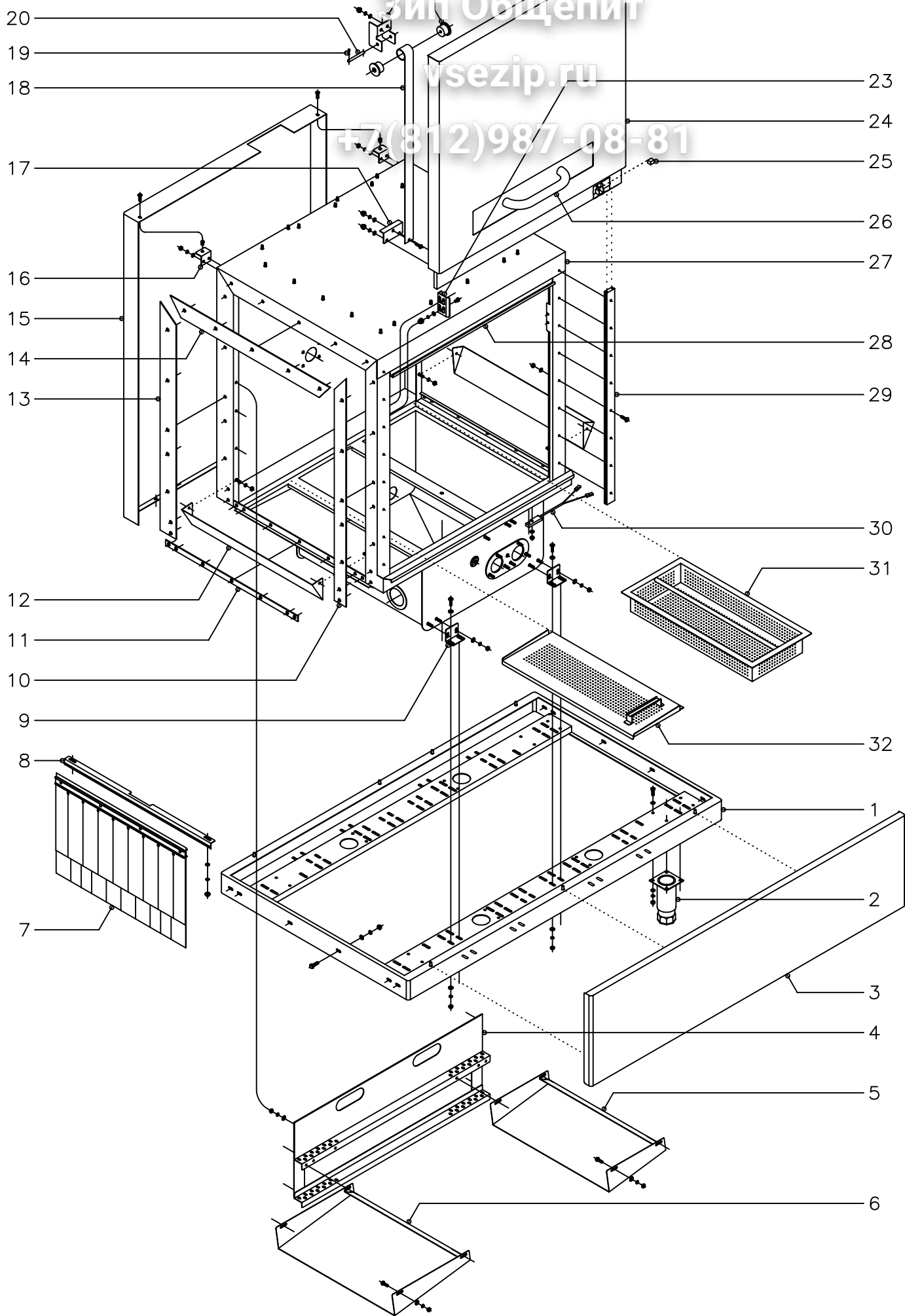

|                   |           |                 |   |             |  |
|-------------------|-----------|-----------------|---|-------------|--|
| N plano<br>C-1547 | Firma<br> | Fecha<br>7-2004 | Aparato<br>LAVAVAJILLAS DE CINTA<br>MODULO DE LAVADO (Mueble) | Lamina<br>3 | Fagor Industrial S.Coop. <b>FAGOR</b><br>Onate |
|-------------------|-----------|-----------------|---|-------------|--|

| MOD. |         | LAVAVAJILLAS DE CINTA              | ZONA                            |        | MODULO DE LAVADO ( ) |        |        |  |
|------|---------|------------------------------------|---------------------------------|--------|----------------------|--------|--------|--|
| ITEM | CODIGO  | DENOMINACION                       | TEXTO                           | 2700 I | 2700 D               | 4000 I | 4000 D |  |
| 1    | Z510101 | Armazón soldado (Lavad.-aclarad.)  | Welded framework (Wash-rinse)   | 1      | 1                    | 1      | 1      |  |
| 1    | Z530101 | Armazón soldado (Lavado)           | Welded framework (Wash)         | -      | -                    | 1      | 1      |  |
|      | Q012053 | Tornillo hexagonal M-8x20          | Hexagonal screw M-8x20          | 8      | 8                    | 12     | 12     |  |
|      | Q232050 | Arandela plana A-8                 | Flat washer A-8                 | 8      | 8                    | 12     | 12     |  |
|      | Q262050 | Arandela muelle A-8                | Spring A-8 washer               | 8      | 8                    | 12     | 12     |  |
|      | Q162050 | Tuerca hexagonal M-8               | Hexagonal nut M-8               | 8      | 8                    | 12     | 12     |  |
| 2    | X260151 | Pata regulable                     | Ajustable leg                   | 4      | 4                    | 8      | 8      |  |
|      | Q012043 | Tornillo hexagonal M-6x20          | Hexagonal screw M-6x20          | 16     | 16                   | 32     | 32     |  |
|      | Q302022 | Arandela plana Ø16xØ6x1,2          | Flat washer Ø16xØ6x10.2         | 32     | 32                   | 64     | 64     |  |
|      | Q262040 | Arandela muelle A-6                | Spring washer A-6               | 16     | 16                   | 32     | 32     |  |
|      | Q162040 | Tuerca hexagonal M-6               | Hexagonal nut M-6               | 16     | 16                   | 32     | 32     |  |
| 3    | Z512901 | Panel frontal lavado y preaclarado | Washing and rinsing front panel | 1      | 1                    | 1      | 1      |  |
| 3    | Z532901 | Panel frontal lavado               | Washing front panel             | -      | -                    | 1      | 1      |  |
| 4    | Z510321 | Guía lavado completa               | Complete washing guide          | 2      | 2                    | 4      | 4      |  |
|      | Q302022 | Arandela plana Ø16xØ6x1,2          | Flat washer Ø16xØ6x10.2         | 12     | 12                   | 24     | 24     |  |
|      | Q262040 | Arandela muelle A-6                | Spring washer A-6               | 12     | 12                   | 24     | 24     |  |
|      | Q162040 | Tuerca hexagonal M-6               | Hexagonal nut M-6               | 12     | 12                   | 24     | 24     |  |
| 5    | Z510811 | Bandeja retenedor "B"              | Retaining plate "B"             | 1      | 1                    | 2      | 2      |  |
|      | Q012042 | Tornillo hexagonal M-6x15          | Hexagonal screw M-6x15          | 4      | 4                    | 8      | 8      |  |
|      | Q302022 | Arandela plana Ø16xØ6x1,2          | Flat washer Ø16xØ6x10.2         | 4      | 4                    | 8      | 8      |  |
|      | Q262040 | Arandela muelle A-6                | Spring washer A-6               | 4      | 4                    | 8      | 8      |  |
|      | Q162040 | Tuerca hexagonal M-6               | Hexagonal nut M-6               | 4      | 4                    | 8      | 8      |  |
| 6    | Z510812 | Bandeja retenedor "A"              | Retaining plate "A"             | 1      | 1                    | 1      | 1      |  |
|      | Q012042 | Tornillo hexagonal M-6x15          | Hexagonal screw M-6x15          | 4      | 4                    | 8      | 8      |  |
|      | Q302022 | Arandela plana Ø16xØ6x1,2          | Flat washer Ø16xØ6x10.2         | 4      | 4                    | 8      | 8      |  |
|      | Q262040 | Arandela muelle A-6                | Spring washer A-6               | 4      | 4                    | 8      | 8      |  |
|      | Q162040 | Tuerca hexagonal M-6               | Hexagonal nut M-6               | 4      | 4                    | 8      | 8      |  |
| 7    | Z276429 | Cortina interior completa          | Complete inner curtain          | 2      | 2                    | 3      | 3      |  |
| 8    | Z510344 | Sujeción cortina                   | Curtain fastening               | 2      | 2                    | 3      | 3      |  |

# Зип Общепит

vsezip.ru

ZONA

+7(812)987-08-81

| MOD. |         | LAVAVAJILLAS DE CINTA               |                               | ZONA   |        | MODULO DE LAVADO ( I |        |  |  |
|------|---------|-------------------------------------|-------------------------------|--------|--------|----------------------|--------|--|--|
| ITEM | CODIGO  | DENOMINACION                        | TEXTO                         | 2700 I | 2700 D | 4000 I               | 4000 D |  |  |
|      | Q232040 | Arandela plana A-6                  | Flat washer A-6               | 4      | 4      | 6                    | 6      |  |  |
|      | Q262040 | Arandela muelle A-6                 | Spring washer A-6             | 4      | 4      | 6                    | 6      |  |  |
|      | Q162040 | Tuerca hexagonal M-6                | Hexagonal nut M-6             | 4      | 4      | 6                    | 6      |  |  |
| 9    | Z510318 | Amarre cuba lavado                  | Washing drum support          | 4      | 4      | 8                    | 8      |  |  |
|      | Q012042 | Tornillo hexagonal M-6x15           | Hexagonal screw M-6x15        | 8      | 8      | 16                   | 16     |  |  |
|      | Q302022 | Arandela plana Ø16xØ6x1,2           | Flat washer Ø16xØ6x10.2       | 24     | 24     | 48                   | 48     |  |  |
|      | Q262040 | Arandela muelle A-6                 | Spring washer A-6             | 16     | 16     | 32                   | 32     |  |  |
|      | Q162040 | Tuerca hexagonal M-6                | Hexagonal nut M-6             | 16     | 16     | 32                   | 32     |  |  |
| 10   | Z510333 | Perfil anterior izquierdo           | Front left profile            | 1      | 2      | 3                    | 1      |  |  |
| s/n  | Z510334 | Perfil anterior derecho             | Front right profile           | 2      | 1      | 1                    | 3      |  |  |
| 11   | Z510332 | Perfil inferior                     | Lower profile                 | 3      | 3      | 4                    | 4      |  |  |
| 12   | Z510813 | Protector                           | Protector                     | 2      | 2      | 3                    | 3      |  |  |
|      | Q262040 | Arandela muelle A-6                 | Spring washer A-6             | 4      | 4      | 6                    | 6      |  |  |
|      | Q162040 | Tuerca hexagonal M-6                | Hexagonal nut M-6             | 4      | 4      | 6                    | 6      |  |  |
| 13   | Z510336 | Perfil posterior izquierdo          | Rear left profile             | 1      | 2      | 3                    | 1      |  |  |
| s/n  | Z510335 | Perfil posterior derecho            | Rear right profile            | 2      | 1      | 1                    | 3      |  |  |
| 14   | Z510337 | Perfil superior izquierdo           | Upper left profile            | 1      | 2      | 3                    | 1      |  |  |
| s/n  | Z510338 | Perfil superior derecho             | Upper right profile           | 2      | 1      | 1                    | 3      |  |  |
| 15   | Z512927 | Panel posterior lavado izquierdo    | Left wash rear panel          | 1      | -      | -                    | -      |  |  |
| 15   | Z512926 | Panel posterior lavado derecho      | Right wash rear panel         | -      | 1      | -                    | -      |  |  |
| 15   | Z512930 | Panel poster. lavado central decho. | Rear panel. right centre wash | -      | -      | 1                    | 1      |  |  |
| 15   | Z512931 | Panel posterlor lavado central      | Rear panel centre wash        | -      | -      | -                    | -      |  |  |
| 15   | Z512933 | Panel poster. prelavado izquierdo   | Rear panel. Left pre-wash     | -      | -      | 1                    | -      |  |  |
| 15   | Z512932 | Panel poster. prelavado derecho     | Rear panel. Right pre-wash    | -      | -      | -                    | 1      |  |  |
|      | Q152004 | Tornillo aplastado M-5x13           | Screw M-5x13                  | 2      | 2      | 4                    | 4      |  |  |
|      | Q221342 | Remache hexagonal M-5               | Hexagonal rivet M-5           | 2      | 2      | 4                    | 4      |  |  |
| 16   | Z512963 | Soporte panel posterior             | Rear panel support            | 2      | 2      | 4                    | 4      |  |  |
|      | Q302022 | Arandela plana Ø16xØ6x1,2           | Flat washer Ø16xØ6x10.2       | 4      | 4      | 8                    | 8      |  |  |
|      | Q262040 | Arandela muelle A-6                 | Spring washer A-6             | 4      | 4      | 8                    | 8      |  |  |

# Зип Ощепит

vsezip.ru

ZONA

MODULO DE LAVADO (

MOD.

LAVAVAJILLAS DE CINTA

+7(812)987-08-81

| ITEM | CODIGO  | DENOMINACION                       | TEXTO                           | 2700 I | 2700 D | 4000 I | 4000 D |
|------|---------|------------------------------------|---------------------------------|--------|--------|--------|--------|
|      | Q162040 | Tuerca hexagonal M-6               | Hexagonal nut M-6               | 4      | 4      | 8      | 8      |
| 17   | Z510508 | Sujeción resorte                   | Rivet support                   | 2      | 2      | 4      | 4      |
|      | Q232040 | Arandela plana A-6                 | Flat washer A-6                 | 4      | 4      | 8      | 8      |
|      | Q262030 | Arandela muelle A-5                | Spring washer A-5               | 4      | 4      | 8      | 8      |
|      | Q212031 | Tuerca sombrerete M-5              | Cowl nut M-5                    | 4      | 4      | 8      | 8      |
| 18   | Z270513 | Resorte fuerza constante           | Constant force spring           | 2      | 2      | 4      | 4      |
|      | Q152004 | Tornillo aplastado M-5x13          | Screw M-5x13                    | 2      | 2      | 4      | 4      |
|      | Q232040 | Arandela plana A-6                 | Flat washer A-6                 | 2      | 2      | 4      | 4      |
|      | Q262030 | Arandela muelle A-5                | Spring washer A-5               | 2      | 2      | 4      | 4      |
|      | Q212031 | Tuerca sombrerete M-5              | Cowl nut M-5                    | 2      | 2      | 4      | 4      |
| 19   | Q352001 | Pasador de aletas Ø2x15            | Cotter pin Ø2x15                | 4      | 4      | 8      | 8      |
| 20   | Z270514 | Eje resorte                        | Spindle spring                  | 2      | 2      | 4      | 4      |
| 21   | Z510514 | Soporte resorte                    | Spring support                  | 2      | 2      | 4      | 4      |
|      | Q232040 | Arandela plana A-6                 | Flat washer A-6                 | 4      | 4      | 8      | 8      |
|      | Q262030 | Arandela muelle A-5                | Spring washer A-5               | 4      | 4      | 8      | 8      |
|      | Q212031 | Tuerca sombrerete M-5              | Cowl nut M-5                    | 4      | 4      | 8      | 8      |
| 22   | Z270512 | Encaje resorte puerta              | Door socket spring              | 4      | 4      | 8      | 8      |
| 23   | Z270531 | Sujeción puerta                    | Door fastening                  | 1      | 1      | 2      | 2      |
|      | Q152047 | Tornillo cilíndrico con cuello M-5 | Cylindrical screw with neck M-5 | 2      | 2      | 4      | 4      |
|      | Q302022 | Arandela plana Ø16xØ6x1,2          | Flat washer Ø16xØ6x10.2         | 2      | 2      | 4      | 4      |
|      | Q262030 | Arandela muelle A-5                | Spring washer A-5               | 2      | 2      | 4      | 4      |
|      | Q212031 | Tuerca sombrerete M-5              | Cowl nut M-5                    | 2      | 2      | 4      | 4      |
| 24   | Z510500 | Puerta lavado completa             | Complete wash door              | 1      | 1      | 2      | 2      |
| 25   | Z200506 | Imán puerta                        | Door magnet                     | 1      | 1      | 2      | 2      |
| 26   | Z200550 | Asa puerta completa                | Complete door handle            | 1      | 1      | 2      | 2      |
| 27   | Z510300 | Caja-cuba lavado soldada           | Welded wash box-tub             | 1      | 1      | 2      | 2      |
| 28   | Z510308 | Suplemento caja lavado completo    | Complete wash box supplement    | 1      | 1      | 2      | 2      |
|      | Q302022 | Arandela plana Ø16xØ6x1,2          | Flat washer Ø16xØ6x10.2         | 4      | 4      | 8      | 8      |
|      | Q262040 | Arandela muelle A-6                | Spring washer A-6               | 4      | 4      | 8      | 8      |

| MOD. |         | LAVAVAJILLAS DE CINTA            | ZONA                     | MODULO DE LAVADO (M |        |        |        |
|------|---------|----------------------------------|--------------------------|---------------------|--------|--------|--------|
| ITEM | CODIGO  | DENOMINACION                     | TEXTO                    | 2700 I              | 2700 D | 4000 I | 4000 D |
|      | Q162040 | Tuerca hexagonal M-6             | Hexagonal nut M-6        | 4                   | 4      | 8      | 8      |
| 29   | Z510331 | Guía puerta                      | Door guide               | 2                   | 2      | 4      | 4      |
|      | Q152045 | Tornillo amarre M-6x25           | Anchoring screw M-6x25   | 16                  | 16     | 16     | 16     |
|      | Q232040 | Arandela plana A-6               | Flat washer A-6          | 16                  | 16     | 16     | 16     |
|      | Q222012 | Tuerca autoblocante M-6          | Autolock nut M-6         | 16                  | 16     | 16     | 16     |
| 30   | Z100522 | Interruptor magnético ( puerta ) | Magnetic switch ( door ) | 1                   | 1      | 2      | 2      |
|      | Q242020 | Arandela abanico A-4             | Fan shaped washer A-4    | 2                   | 2      | 4      | 4      |
|      | Q162020 | Tuerca hexagonal M-4             | Hexagonal nut M-4        | 2                   | 2      | 4      | 4      |
| 31   | Z510801 | Bandeja lavado "A" completa      | Complete wash plate "A"  | 2                   | 2      | 4      | 4      |
| 32   | Z510804 | Bandeja lavado "B" completa      | Complete wash plate "B"  | 1                   | 1      | 2      | 2      |
|      |         |                                  |                          |                     |        |        |        |
|      |         |                                  |                          |                     |        |        |        |
|      |         |                                  |                          |                     |        |        |        |
|      |         |                                  |                          |                     |        |        |        |
|      |         |                                  |                          |                     |        |        |        |
|      |         |                                  |                          |                     |        |        |        |
|      |         |                                  |                          |                     |        |        |        |
|      |         |                                  |                          |                     |        |        |        |
|      |         |                                  |                          |                     |        |        |        |
|      |         |                                  |                          |                     |        |        |        |
|      |         |                                  |                          |                     |        |        |        |
|      |         |                                  |                          |                     |        |        |        |
|      |         |                                  |                          |                     |        |        |        |
|      |         |                                  |                          |                     |        |        |        |
|      |         |                                  |                          |                     |        |        |        |
|      |         |                                  |                          |                     |        |        |        |
|      |         |                                  |                          |                     |        |        |        |
|      |         |                                  |                          |                     |        |        |        |
|      |         |                                  |                          |                     |        |        |        |
|      |         |                                  |                          |                     |        |        |        |

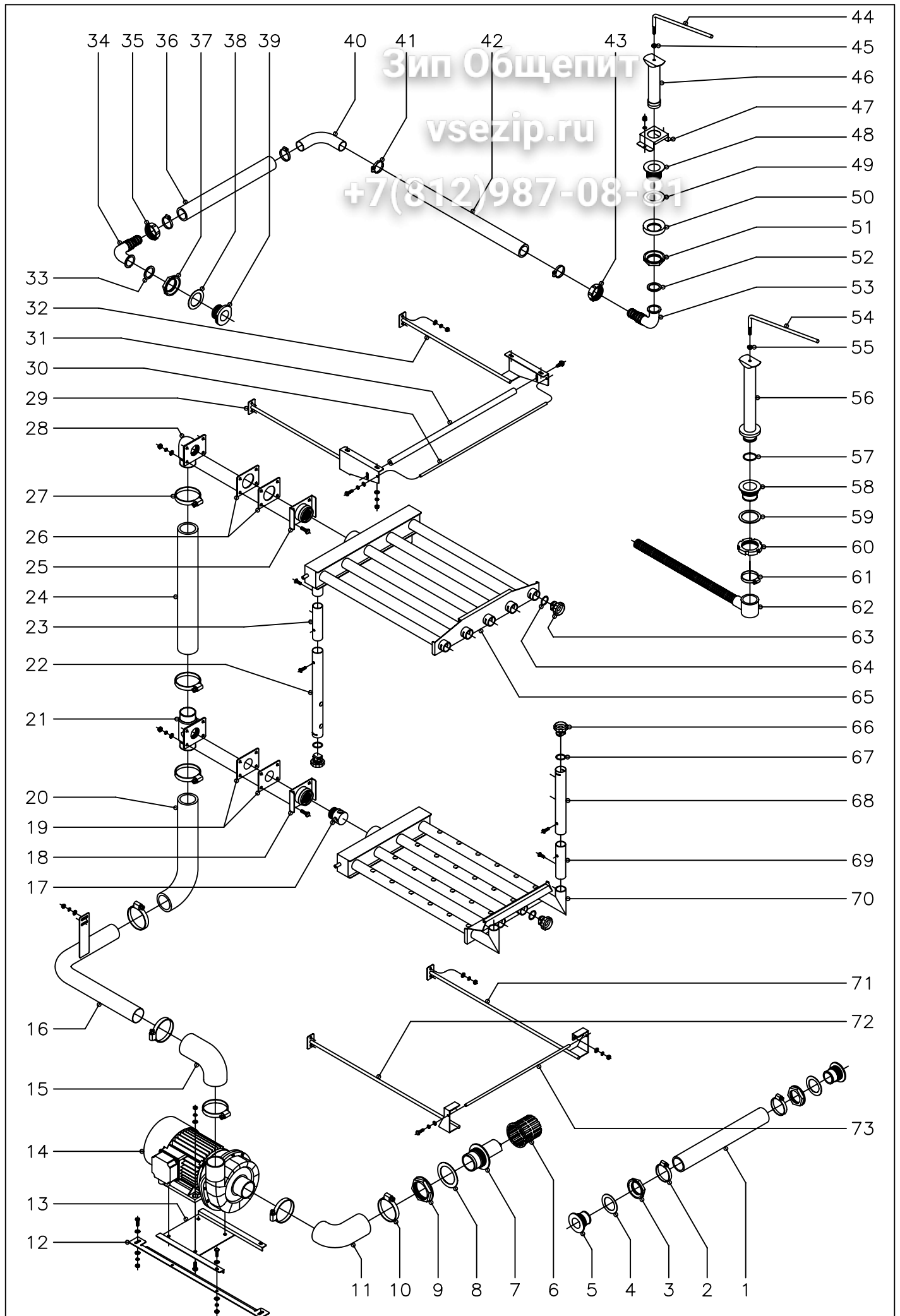

|                   |           |                 |  |             |                                       |
|-------------------|-----------|-----------------|--|-------------|---------------------------------------|
| N plano<br>C-1548 | Firma<br> | Fecha<br>7-2004 | Aparato<br>LAVAVAJILLAS DE CINTA<br>PARTE FUNCIONAL LAVADO | Lamina<br>4 | Fagor Industrial S.Coop. <b>FAGOR</b> |
|                   |           |                 |  |             | Onate                                 |

# Зип Общепит

vsezip.ru

ZONA

+7(812)987-08-81

| MOD. |         | LAVAVAJILLAS DE CINTA        |                               | MODULO DE LAVADO ( Part |        |        |        |
|------|---------|------------------------------|-------------------------------|-------------------------|--------|--------|--------|
| ITEM | CODIGO  | DENOMINACION                 | TEXTO                         | 2700 I                  | 2700 D | 4000 I | 4000 D |
| 1    | Z330906 | Manguera comunicación        | Connection pipe               | -                       | -      | 1      | 1      |
| 2    | Q881324 | Abrazadera 50 -70            | Clamp 50-70                   | -                       | -      | 2      | 2      |
| 3    | Z702101 | Tuerca R-1 1/2"              | Nut R-1 1/2"                  | -                       | -      | 2      | 2      |
| 4    | Q307009 | Arandela junta Ø70xØ48x1,5   | Joint washer Ø70xØ48x10.5     | -                       | -      | 2      | 2      |
| 5    | Z330901 | Pasamuros comunicación       | Connection wire protection    | -                       | -      | 2      | 2      |
| 6    | Z310906 | Filtro aspiración            | Extractor filter              | 1                       | 1      | 2      | 2      |
| 7    | Z310901 | Pasamuros aspiración         | Extractor wire protection     | 1                       | 1      | 2      | 2      |
| 8    | Z310902 | Arandela junta Ø92xØ66x2     | Joint washer Ø92xØ66x2        | 1                       | 1      | 2      | 2      |
| 9    | Z310903 | Tuerca pasamuros M-65X2,5    | Wire protection nut M-65X20.5 | 1                       | 1      | 2      | 2      |
| 10   | Q881326 | Abrazadera 70 - 90           | Clamp 70 - 90                 | 3                       | 3      | 6      | 6      |
| 11   | Z310904 | Codo aspiración              | Extractor elbow               | 1                       | 1      | 2      | 2      |
| 12   | Z511003 | Sujeción motobomba lavado    | Wash motor pump fastener      | 2                       | 2      | 4      | 4      |
|      | Q012042 | Tornillo hexagonal M-6x15    | Hexagonal screw M-6x15        | 4                       | 4      | 8      | 8      |
|      | Q302022 | Arandela plana Ø16xØ6x1,2    | Flat washer Ø16xØ6x10.2       | 8                       | 8      | 16     | 16     |
|      | Q262040 | Arandela muelle A-6          | Spring washer A-6             | 4                       | 4      | 8      | 8      |
|      | Q162040 | Tuerca hexagonal M-6         | Hexagonal nut M-6             | 4                       | 4      | 8      | 8      |
| 13   | Z511002 | Soporte motobomba            | Motor pump support            | 1                       | 1      | 2      | 2      |
|      | Q012042 | Tornillo hexagonal M-6x15    | Hexagonal screw M-6x15        | 2                       | 2      | 4      | 4      |
|      | Q302022 | Arandela plana Ø16xØ6x1,2    | Flat washer Ø16xØ6x10.2       | 4                       | 4      | 8      | 8      |
|      | Q262040 | Arandela muelle A-6          | Spring washer A-6             | 2                       | 2      | 4      | 4      |
|      | Q162040 | Tuerca hexagonal M-6         | Hexagonal nut M-6             | 2                       | 2      | 4      | 4      |
| 14   | Z511001 | Motobomba ( 220/380, 50 Hz.) | Motor pump ( 220/380, 50 Hz.) | 1                       | 1      | 2      | 2      |
| 14   | Z514101 | Motobomba ( 220/380, 60 Hz.) | Motor pump ( 220/380, 60 Hz.) | 1                       | 1      | 2      | 2      |
|      | Q012055 | Tornillo hexagonal M-8x30    | Hexagonal screw M-8x30        | 4                       | 4      | 8      | 8      |
|      | Q232050 | Arandela plana A-8           | Flat washer A-8               | 8                       | 8      | 16     | 16     |
|      | Q262050 | Arandela muelle A-8          | Spring washer A-8             | 4                       | 4      | 8      | 8      |
|      | Q162050 | Tuerca hexagonal M-8         | Hexagonal nut M-8             | 4                       | 4      | 8      | 8      |
| 15   | Z510902 | Codo impulsión               | Impulse elbow                 | 1                       | 1      | 2      | 2      |
| 16   | Z510910 | Codo empalme impulsión comp. | Complete impulse elbow joint  | 1                       | 1      | 2      | 2      |

# Зип Общепит

vsezip.ru

+7(812)987-08-81

| MOD. |         | LAVAVAJILLAS DE CINTA            |                             | ZONA   |        | MODULO DE LAVADO ( Parte |        |  |  |
|------|---------|----------------------------------|-----------------------------|--------|--------|--------------------------|--------|--|--|
| ITEM | CODIGO  | DENOMINACION                     | TEXTO                       | 2700 I | 2700 D | 4000 I                   | 4000 D |  |  |
|      | Q302022 | Arandela plana Ø16xØ6x1,2        | Flat washer Ø16xØ6x10.2     | 2      | 2      | 4                        | 4      |  |  |
|      | Q262040 | Arandela muelle A-6              | Spring washer A-6           | 2      | 2      | 4                        | 4      |  |  |
|      | Q162040 | Tuerca hexagonal M-6             | Hexagonal nut M-6           | 2      | 2      | 4                        | 4      |  |  |
| 17   | Z310753 | Reducción caudal lavado          | Wash flow reduction         | 1      | 1      | 2                        | 2      |  |  |
| 18   | Z510701 | Soporte suplemento soldado       | Welded supplement support   | 1      | 1      | 2                        | 2      |  |  |
|      | Q012055 | Tornillo hexagonal M-8x30        | Hexagonal screw M-8x30      | 4      | 4      | 8                        | 8      |  |  |
| 19   | Z510908 | Junta pasamuros                  | Wire protection joint       | 2      | 2      | 4                        | 4      |  |  |
| 20   | Z510904 | Empalme inferior impulsión       | Lower impulse joint         | 1      | 1      | 2                        | 2      |  |  |
| 21   | Z510905 | Pasamuros lavado inferior        | Lower wash wire protection  | 1      | 1      | 2                        | 2      |  |  |
|      | Q232050 | Arandela plana A-8               | Flat washer A-8             | 4      | 4      | 8                        | 8      |  |  |
|      | Q262050 | Arandela muelle A-8              | Spring washer A-8           | 4      | 4      | 8                        | 8      |  |  |
|      | Q162050 | Tuerca hexagonal M-8             | Hexagonal nut M-8           | 4      | 4      | 8                        | 8      |  |  |
| 22   | Z510725 | Rama lavado lateral superior     | Upper side wash branch      | 2      | 2      | 4                        | 4      |  |  |
| 23   | Z510728 | Suplemento rama lateral          | Side branch supplement      | 2      | 2      | 4                        | 4      |  |  |
|      | Q152004 | Tornillo aplastado M-5x13        | Screw M-5x13                | 4      | 4      | 8                        | 8      |  |  |
| 24   | Z510906 | Empalme superior impulsión       | Upper impulse joint         | 1      | 1      | 2                        | 2      |  |  |
| 25   | Z510701 | Soporte suplemento soldado       | Welded supplement support   | 1      | 1      | 2                        | 2      |  |  |
|      | Q012055 | Tornillo hexagonal M-8x30        | Hexagonal screw M-8x30      | 4      | 4      | 8                        | 8      |  |  |
| 26   | Z510908 | Junta pasamuros                  | Wire protection joint       | 2      | 2      | 4                        | 4      |  |  |
| 27   | Q881326 | Abrazadera 70 - 90               | Clamp 70 - 90               | 5      | 5      | 10                       | 10     |  |  |
| 28   | Z510907 | Pasamuros lavado superior        | Upper wash wire protection  | 1      | 1      | 2                        | 2      |  |  |
|      | Q232050 | Arandela plana A-8               | Flat washer A-8             | 4      | 4      | 8                        | 8      |  |  |
|      | Q262050 | Arandela muelle A-8              | Spring washer A-8           | 4      | 4      | 8                        | 8      |  |  |
|      | Q162050 | Tuerca hexagonal M-8             | Hexagonal nut M-8           | 4      | 4      | 8                        | 8      |  |  |
| 29   | Z510704 | Soporte superior izquierdo comp. | Complete upper left support | 1      | 1      | 2                        | 2      |  |  |
|      | Q302022 | Arandela plana Ø16xØ6x1,2        | Flat washer Ø16xØ6x10.2     | 2      | 2      | 4                        | 4      |  |  |
|      | Q262040 | Arandela muelle A-6              | Spring washer A-6           | 2      | 2      | 4                        | 4      |  |  |
|      | Q162040 | Tuerca hexagonal M-6             | Hexagonal nut M-6           | 2      | 2      | 4                        | 4      |  |  |
| 30   | Z510708 | Varilla sujeción superior        | Upper fastening rod         | 1      | 1      | 2                        | 2      |  |  |



# Зип Общепит

vsezip.ru

ZONA

+7(812)987-08-81

| MOD. |         | LAVAVAJILLAS DE CINTA             | ZONA                          |        | MODULO DE LAVADO ( Par |        |        |  |
|------|---------|-----------------------------------|-------------------------------|--------|------------------------|--------|--------|--|
| ITEM | CODIGO  | DENOMINACION                      | TEXTO                         | 2700 I | 2700 D                 | 4000 I | 4000 D |  |
|      | Q012021 | Tornillo hexagonal M-4x10         | Hexagonal screw M-4x10        | 2      | 2                      | 4      | 4      |  |
|      | Q261020 | Arandela muelle A-4               | Spring washer A-4             | 2      | 2                      | 4      | 4      |  |
|      | Q232020 | Arandela plana A-4                | Flat washer A-4               | 2      | 2                      | 4      | 4      |  |
| 31   | Z510717 | Contrapeso                        | Counter balance               | 1      | 1                      | 2      | 2      |  |
|      | Q152046 | Tornillo hexagonal con cuello M-6 | Hexagonal screw with neck M-6 | 2      | 2                      | 4      | 4      |  |
| 32   | Z510709 | Soporte superior derecho comp.    | Complete upper right support. | 1      | 1                      | 2      | 2      |  |
|      | Q302022 | Arandela plana Ø16xØ6x1,2         | Flat washer Ø16xØ6x10.2       | 2      | 2                      | 4      | 4      |  |
|      | Q262040 | Arandela muelle A-6               | Spring washer A-6             | 2      | 2                      | 4      | 4      |  |
|      | Q162040 | Tuerca hexagonal M-6              | Hexagonal nut M-6             | 2      | 2                      | 4      | 4      |  |
| 33   | Q307027 | Arandela junta Ø45xØ35x2          | Joint washer Ø45xØ35x2        | 1      | 1                      | 1      | 1      |  |
| 34   | Z602101 | Codo desagüe                      | Drainage elbow                | 1      | 1                      | 1      | 1      |  |
| 35   | Z602102 | Tuerca                            | Nut                           | 1      | 1                      | 1      | 1      |  |
| 36   | Z310912 | Manguera comunicación             | Connection pipe               | 1      | 1                      | 1      | 1      |  |
| 37   | Z702101 | Tuerca R-1 1/2"                   | Nut R-1 1/2"                  | 1      | 1                      | 1      | 1      |  |
| 38   | Q307009 | Arandela junta Ø70xØ48x1,5        | Joint washer Ø70xØ48x10.5     | 1      | 1                      | 1      | 1      |  |
| 39   | Z510931 | Pasamuros                         | Wire protection               | 1      | 1                      | 1      | 1      |  |
| 40   | Z310932 | Codo empalme                      | Elbow joint                   | 1      | 1                      | 1      | 1      |  |
| 41   | Q881307 | Abrazadera 40 - 60                | Clamp 40 - 60                 | 4      | 4                      | 4      | 4      |  |
| 42   | Z510934 | Manguera comunicación preaclar.   | Prerinse connection pipe      | 1      | 1                      | 1      | 1      |  |
| 43   | Z602102 | Tuerca                            | Nut                           | 1      | 1                      | 1      | 1      |  |
| 44   | Z510924 | Asa aliviadero preaclarado        | Prerinse overflow handle      | 1      | 1                      | 1      | 1      |  |
| 45   | Q162050 | Tuerca hexagonal M-8              | Hexagonal nut M-8             | 1      | 1                      | 1      | 1      |  |
| 46   | Z510921 | Aliviadero preaclarado soldado    | Welded prerinse overflow      | 1      | 1                      | 1      | 1      |  |
| 47   | Z510941 | Guía aliviadero preaclarado       | Prerinse overflow guide       | 1      | 1                      | 1      | 1      |  |
|      | Q262040 | Arandela muelle A-6               | Spring washer A-6             | 2      | 2                      | 2      | 2      |  |
|      | Q212040 | Tuerca sombrerete M-6             | Cowl nut M-6                  | 2      | 2                      | 2      | 2      |  |
| 48   | Z102104 | Válvula desagüe                   | Drainage valve                | 1      | 1                      | 1      | 1      |  |
| 49   | Q307009 | Arandela junta Ø70xØ48x1,5        | Joint washer Ø70xØ48x10.5     | 1      | 1                      | 1      | 1      |  |
| 50   | Q307026 | Junta especial                    | Special joint                 | 1      | 1                      | 1      | 1      |  |

# Зип Общепит

vsezip.ru

ZONA

MODULO DE LAVADO ( Par

MOD.

LAVAVAJILLAS DE CINTA

+7(812)987-08-81

| ITEM | CODIGO  | DENOMINACION                        | TEXTO                           | 2700 I | 2700 D | 4000 I | 4000 D |
|------|---------|-------------------------------------|---------------------------------|--------|--------|--------|--------|
| 51   | Z702101 | Tuerca rosca 1 1/2"                 | Nut thread 1 1/2"               | 1      | 1      | 1      | 1      |
| 52   | Q307027 | Arandela junta Ø45xØ35x2            | Joint washer Ø45xØ35x2          | 1      | 1      | 1      | 1      |
| 53   | Z602101 | Codo desagüe                        | Drainage elbow                  | 1      | 1      | 1      | 1      |
| 54   | Z510916 | Asa aliviadero lavado               | Wash overflow handle            | 1      | 1      | 1      | 1      |
| 55   | Q162050 | Tuerca hexagonal M-8                | Hexagonal nut M-8               | 1      | 1      | 1      | 1      |
| 56   | Z510911 | Aliviadero lavado soldado           | Welded wash overflow            | 1      | 1      | 1      | 1      |
| 57   | Q307051 | Junta tórica Ø41,41xØ36,17xØ2,6     | "O" ring Ø41,41xØ36,17xØ2,6     | 1      | 1      | 1      | 1      |
| 58   | Z710902 | Pasamuros desagüe                   | Drainage wire protection        | 1      | 1      | 1      | 1      |
| 59   | Q307059 | Arandela junta Ø72xØ56x2            | Joint washer Ø72xØ56x2          | 1      | 1      | 1      | 1      |
| 60   | Q220001 | Tuerca ranurada M-56x2,5            | Slotted nut M-56x2,5            | 1      | 1      | 1      | 1      |
| 61   | Q881324 | Abrazadera 50 - 70                  | Clamp 50 - 70                   | 1      | 1      | 1      | 1      |
| 62   | Z200910 | Manguera desagüe                    | Drainage pipe                   | 1      | 1      | 1      | 1      |
| 63   | Z310721 | Tapón cierre                        | Closure plug                    | 7      | 7      | 14     | 14     |
| 64   | Q307068 | Junta tórica Ø33xØ27xØ3             | "O" ring Ø33xØ27xØ3             | 7      | 7      | 14     | 14     |
| 65   | Z510719 | Distribuidor superior lavado comp.  | Complete wash upper distributor | 1      | 1      | 2      | 2      |
| 66   | Z310721 | Tapón cierre                        | Closure plug                    | 4      | 4      | 8      | 8      |
| 67   | Q307068 | Junta tórica Ø33xØ27xØ3             | "O" ring Ø33xØ27xØ3             | 4      | 4      | 8      | 8      |
| 68   | Z510747 | Rama lavado lateral inferior        | Lower side wash branch          | 2      | 2      | 4      | 4      |
| 69   | Z510728 | Suplemento rama lateral             | Side branch supplement          | 2      | 2      | 4      | 4      |
|      | Q152004 | Tornillo aplastado M-5x13           | Screw M-5x13                    | 4      | 4      | 8      | 8      |
| 70   | Z510739 | Distribuidor inferior lavado comp.  | Complete wash lower distributor | 1      | 1      | 2      | 2      |
| 71   | Z510715 | Soporte inferior derecho completo   | Complete lower right support    | 1      | 1      | 2      | 2      |
| 72   | Z510711 | Soporte inferior izquierdo completo | Complete lower left support     | 1      | 1      | 2      | 2      |
|      | Q302022 | Arandela plana Ø16xØ6x1,2           | Flat washer Ø16xØ6x1,2          | 4      | 4      | 8      | 8      |
|      | Q262040 | Arandela muelle A-6                 | Spring washer A-6               | 4      | 4      | 8      | 8      |
|      | Q162040 | Tuerca hexagonal M-6                | Hexagonal nut M-6               | 4      | 4      | 8      | 8      |
| 73   | Z510714 | Varilla sujeción inferior           | Lower fastening rod             | 1      | 1      | 2      | 2      |
|      | Q012021 | Tornillo hexagonal M-4x10           | Hexagonal screw M-4x10          | 2      | 2      | 4      | 4      |
|      | Q261020 | Arandela muelle A-4                 | Spring washer A-4               | 2      | 2      | 4      | 4      |
|      | Q232020 | Arandela plana A-4                  | Flat washer A-4                 | 2      | 2      | 4      | 4      |

Зип Общепит

vsezip.ru

+7(812)987-08-81

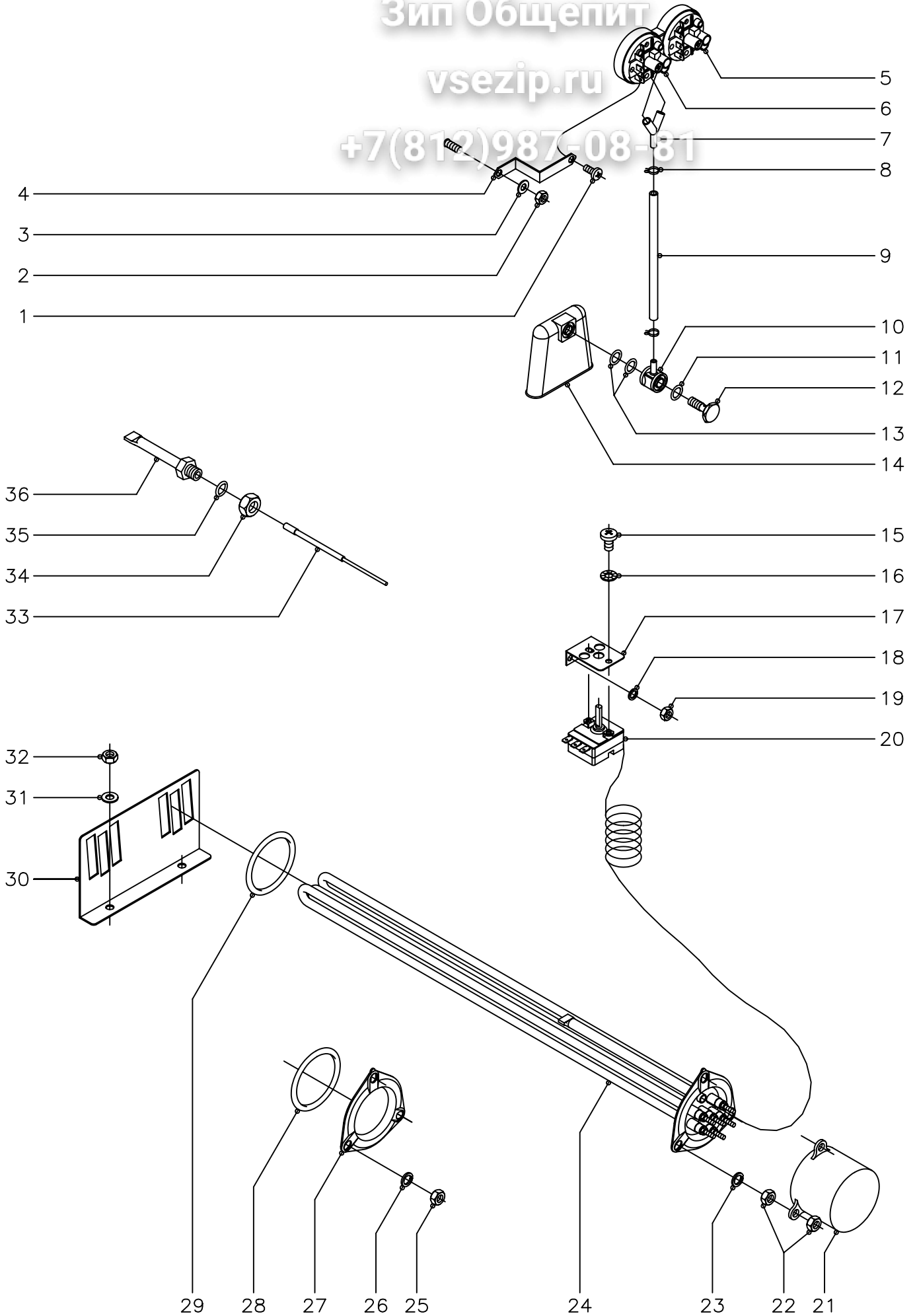

|                   |           |                 |  |             |  |
|-------------------|-----------|-----------------|--|-------------|--|
| N plano<br>C-1549 | Firma<br> | Fecha<br>7-2004 | Aparato<br>LAVAVAJILLAS DE CINTA<br>NIVELES Y CALENTAMIENTO LAVADO | Lamina<br>5 | Fagor Industrial S.Coop. <b>FAGOR</b><br>Onate |
|-------------------|-----------|-----------------|--|-------------|--|

# Зип Ощепит

vsezip.ru

ZONA

MODULO DE LAVADO ( Niveles y

MOD.

LAVAVAJILLAS DE CINTA

+7(812)987-08-81

| ITEM | CODIGO  | DENOMINACION                     | TEXTO                         | 2700 I | 2700 D | 4000 I | 4000 D |
|------|---------|----------------------------------|-------------------------------|--------|--------|--------|--------|
| 1    | Q082032 | Tornillo alomado BZ-3,5x9,5      | Curved screw BZ-3.5x90.5      | 1      | 1      | 2      | 2      |
| 2    | Q162040 | Tuerca hexagonal M-6             | Hexagonal nut M-6             | 1      | 1      | 2      | 2      |
| 3    | Q232040 | Arandela plana A-6               | Flat washer A-6               | 1      | 1      | 2      | 2      |
| 4    | Z602923 | Soporte presostato               | Pressostat support            | 1      | 1      | 2      | 2      |
| 5    | Z103074 | Presostato simple                | Simple pressostat             | 1      | 1      | 2      | 2      |
| 6    | Z513001 | Presostato simple                | Simple pressostat             | 1      | 1      | 2      | 2      |
| 7    | Z103077 | Racord en "Y"                    | "Y" joint                     | 1      | 1      | 2      | 2      |
| 8    | P102154 | Brida elástica                   | Elastic yoke                  | 2      | 2      | 4      | 4      |
| 9    | 3702400 | Tubo de goma Ø 8x4x240           | Rubber pipe Ø 8x4x240         | 1      | 1      | 2      | 2      |
| 10   | Z203012 | Empalme presostato               | Pressostat joint              | 1      | 1      | 2      | 2      |
| 11   | Q307003 | Junta tórica Ø16,01xØ10,77xØ2,62 | "O" ring Ø16,01xØ10,77xØ20.62 | 1      | 1      | 2      | 2      |
| 12   | Z203013 | Tornillo presostato              | Pressostat screw              | 1      | 1      | 2      | 2      |
| 13   | Q307003 | Junta tórica Ø16,01xØ10,77xØ2,62 | "O" ring Ø16,01xØ10,77xØ20.62 | 2      | 2      | 4      | 4      |
| 14   | Z203011 | Cámara presostato                | Pressostat chamber            | 1      | 1      | 2      | 2      |
| 15   | Q152024 | Tornillo avellanado M-4x8        | Countersunk screw M-4x8       | 2      | 2      | 2      | 2      |
| 16   | Q242020 | Arandela abanico A-4             | Fan shaped washer A-4         | 2      | 2      | 2      | 2      |
| 17   | Z850111 | Soporte termostato               | Thermostat support            | 1      | 1      | 1      | 1      |
| 18   | Q232040 | Arandela plana A-6               | Flat washer A-6               | 2      | 2      | 2      | 2      |
| 19   | Q162040 | Tuerca hexagonal M-6             | Hexagonal nut M-6             | 2      | 2      | 2      | 2      |
| 20   | Z203014 | Termostato                       | Thermostat                    | 1      | 1      | 1      | 1      |
| 21   | Z101723 | Caperuza resistencia             | Resistor cap                  | 2      | 2      | 2      | 2      |
| 22   | Q163140 | Tuerca hexagonal M-6 LATÓN       | Brass hexagonal nut M-6       | 12     | 12     | 12     | 12     |
| 23   | Q262040 | Arandela muelle A-6              | Spring washer A-6             | 6      | 6      | 6      | 6      |
| 24   | Z121741 | Resistencia 230 V., 9.600 W.     | Resistance 230 V., 9,600 W.   | 2      | 2      | 2      | 2      |
| 24   | Z129502 | Resistencia 230 V., 12.000 W.    | Resistance 230 V., 12,000 W.  | -      | -      | -      | -      |
| 25   | Q163040 | Tuerca hexagonal M-6 LATÓN       | Brass hexagonal nut M-6       | -      | -      | 6      | 6      |
| 26   | Q262040 | Arandela muelle A-6              | Spring washer A-6             | -      | -      | 6      | 6      |
| 27   | Z310703 | Brida ciega                      | Blind yoke                    | -      | -      | 2      | 2      |
| 28   | Q307044 | Junta tórica Ø67,18xØ56,52xØ5,30 | "O" ring Ø67,18xØ56,52xØ50.30 | -      | -      | 2      | 2      |

| MOD. |         | LAVAVAJILLAS DE CINTA                |                                    | ZONA |        | MODULO DE LAVADO ( Niveles ) |        |        |  |
|------|---------|--------------------------------------|------------------------------------|------|--------|------------------------------|--------|--------|--|
| ITEM | CODIGO  | DENOMINACION                         | TEXTO                              |      | 2700 I | 2700 D                       | 4000 I | 4000 D |  |
| 29   | Q307044 | Junta tórica Ø67,18xØ56,52xØ5,30     | "O" ring Ø67,18xØ56,52xØ50.30      |      | 2      | 2                            | 2      | 2      |  |
| 30   | Z513602 | Sujeción resistencia                 | Resistor fastener                  |      | 1      | 1                            | 1      | 1      |  |
| 31   | Q232040 | Arandela plana A-6                   | Flat washer A-6                    |      | 2      | 2                            | 2      | 2      |  |
| 32   | Q162040 | Tuerca hexagonal M-6                 | Hexagonal nut M-6                  |      | 2      | 2                            | 2      | 2      |  |
| 33   | Z263001 | Indicador analógico tanque lavado    | Wash tank analogical indicator     |      | 1      | 1                            | 1      | 1      |  |
| 34   | Q162070 | Tuerca hexagonal M-12                | Hexagonal nut M-12                 |      | 1      | 1                            | 1      | 1      |  |
| 35   | Q307048 | Junta tórica Ø16,18xØ9,12xØ3,53      | "O" ring Ø16,18xØ9,12xØ30.53       |      | 1      | 1                            | 1      | 1      |  |
| 36   | Z263002 | Vaina para bulbo indicador analógico | Case for analogical indicator bulb |      | 1      | 1                            | 1      | 1      |  |
|      |         |                                      |                                    |      |        |                              |        |        |  |
|      |         |                                      |                                    |      |        |                              |        |        |  |
|      |         |                                      |                                    |      |        |                              |        |        |  |
|      |         |                                      |                                    |      |        |                              |        |        |  |
|      |         |                                      |                                    |      |        |                              |        |        |  |
|      |         |                                      |                                    |      |        |                              |        |        |  |
|      |         |                                      |                                    |      |        |                              |        |        |  |
|      |         |                                      |                                    |      |        |                              |        |        |  |
|      |         |                                      |                                    |      |        |                              |        |        |  |
|      |         |                                      |                                    |      |        |                              |        |        |  |
|      |         |                                      |                                    |      |        |                              |        |        |  |
|      |         |                                      |                                    |      |        |                              |        |        |  |
|      |         |                                      |                                    |      |        |                              |        |        |  |
|      |         |                                      |                                    |      |        |                              |        |        |  |
|      |         |                                      |                                    |      |        |                              |        |        |  |
|      |         |                                      |                                    |      |        |                              |        |        |  |
|      |         |                                      |                                    |      |        |                              |        |        |  |
|      |         |                                      |                                    |      |        |                              |        |        |  |
|      |         |                                      |                                    |      |        |                              |        |        |  |

Зип Общепит

vsezip.ru

+7(812)987-08-81

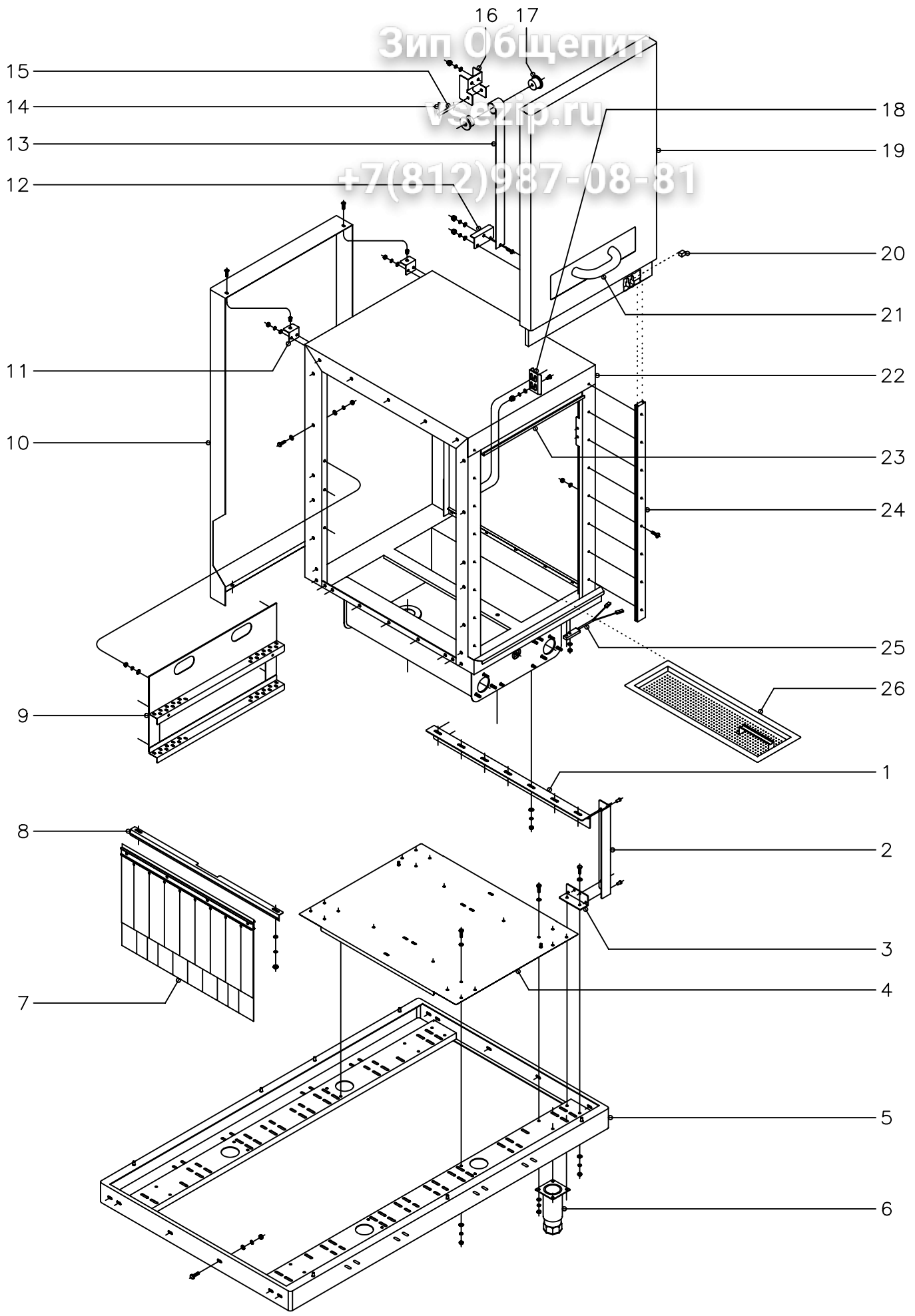

|                   |           |                 |  |             |                                       |
|-------------------|-----------|-----------------|--|-------------|---------------------------------------|
| N plano<br>C-1550 | Firma<br> | Fecha<br>7-2004 | Aparato<br>LAVAVAJILLAS DE CINTA<br>MODULO DE PREACLARADO (Mueble) | Lamina<br>6 | Fagor Industrial S.Coop. <b>FAGOR</b> |
|-------------------|-----------|-----------------|--|-------------|---------------------------------------|

# Зип Общепит

vsezip.ru

ZONA

MODULO DE PREACLAR

MOD.

LAVAVAJILLAS DE CINTA

+7(812)987-08-81

| ITEM | CODIGO  | DENOMINACION                      | TEXTO                              | 2700 I | 2700 D | 4000 I | 4000 D |
|------|---------|-----------------------------------|------------------------------------|--------|--------|--------|--------|
| 1    | Z510113 | Larguero soporte                  | Crossbar support                   | 1      | 1      | 1      | 1      |
|      | Q302022 | Arandela plana Ø16xØ6x1,2         | Flat washer Ø16xØ6x10.2            | 7      | 7      | 7      | 7      |
|      | Q262040 | Arandela muelle A-6               | Spring washer A-6                  | 7      | 7      | 7      | 7      |
|      | Q162040 | Tuerca hexagonal M-6              | Hexagonal nut M-6                  | 7      | 7      | 7      | 7      |
| 2    | Z510114 | Poste                             | Post                               | 2      | 2      | 2      | 2      |
|      | Q411304 | Remache avibulb Ø4,8              | Avibulb rivet Ø40.8                | 8      | 8      | 8      | 8      |
| 3    | Z510112 | Base soporte                      | Support base                       | 2      | 2      | 2      | 2      |
|      | Q012043 | Tornillo hexagonal M-6x20         | Hexagonal screw M-6x20             | 4      | 4      | 4      | 4      |
|      | Q302022 | Arandela plana Ø16xØ6x1,2         | Flat washer Ø16xØ6x10.2            | 8      | 8      | 8      | 8      |
|      | Q262040 | Arandela muelle A-6               | Spring washer A-6                  | 4      | 4      | 4      | 4      |
|      | Q162040 | Tuerca hexagonal M-6              | Hexagonal nut M-6                  | 4      | 4      | 4      | 4      |
| 4    | Z510104 | Panel transversal preaclarado com | Complete prerinse transverse panel | 1      | 1      | 1      | 1      |
|      | Q012043 | Tornillo hexagonal M-6x20         | Hexagonal screw M-6x20             | 4      | 4      | 4      | 4      |
|      | Q302022 | Arandela plana Ø16xØ6x1,2         | Flat washer Ø16xØ6x10.2            | 8      | 8      | 8      | 8      |
|      | Q262040 | Arandela muelle A-6               | Spring washer A-6                  | 4      | 4      | 4      | 4      |
|      | Q162040 | Tuerca hexagonal M-6              | Hexagonal nut M-6                  | 4      | 4      | 4      | 4      |
| 5    | Z510101 | Armazón soldado (Lavad.-aclarad.) | Welded framework (Wash-rinse)      | 1      | 1      | 1      | 1      |
|      | Q012053 | Tornillo hexagonal M-8x20         | Hexagonal screw M-8x20             | 8      | 8      | 12     | 12     |
|      | Q232050 | Arandela plana A-8                | Flat washer A-8                    | 8      | 8      | 12     | 12     |
|      | Q262050 | Arandela muelle A-8               | Spring washer A-8                  | 8      | 8      | 12     | 12     |
|      | Q162050 | Tuerca hexagonal M-8              | Hexagonal nut M-8                  | 8      | 8      | 12     | 12     |
| 6    | X260151 | Pata regulable                    | Ajustable leg                      | 4      | 4      | 8      | 8      |
|      | Q012043 | Tornillo hexagonal M-6x20         | Hexagonal screw M-6x20             | 16     | 16     | 32     | 32     |
|      | Q302022 | Arandela plana Ø16xØ6x1,2         | Flat washer Ø16xØ6x10.2            | 32     | 32     | 64     | 64     |
|      | Q262040 | Arandela muelle A-6               | Spring washer A-6                  | 16     | 16     | 32     | 32     |
|      | Q162040 | Tuerca hexagonal M-6              | Hexagonal nut M-6                  | 16     | 16     | 32     | 32     |
| 7    | Z276429 | Cortina interior completa         | Complete inner curtain             | 1      | 1      | 1      | 1      |
| 8    | Z510344 | Sujeción cortina                  | Curtain fastening                  | 1      | 1      | 1      | 1      |
|      | Q232040 | Arandela plana A-6                | Flat washer A-6                    | 2      | 2      | 2      | 2      |

# Зип Общепит

vsezip.ru

+7(812)987-08-81

| MOD. |         | LAVAVAJILLAS DE CINTA              | ZONA                      | MODULO DE PREACLARADO |        |        |        |
|------|---------|------------------------------------|---------------------------|-----------------------|--------|--------|--------|
| ITEM | CODIGO  | DENOMINACION                       | TEXTO                     | 2700 I                | 2700 D | 4000 I | 4000 D |
|      | Q262040 | Arandela muelle A-6                | Spring washer A-6         | 2                     | 2      | 2      | 2      |
|      | Q162040 | Tuerca hexagonal M-6               | Hexagonal nut M-6         | 2                     | 2      | 2      | 2      |
| 9    | Z511811 | Guía preaclarado completa          | Complete prerinse guide   | 2                     | 2      | 2      | 2      |
|      | Q302022 | Arandela plana Ø16xØ6x1,2          | Flat washer Ø16xØ6x10.2   | 12                    | 12     | 12     | 12     |
|      | Q262040 | Arandela muelle A-6                | Spring washer A-6         | 12                    | 12     | 12     | 12     |
|      | Q162040 | Tuerca hexagonal M-6               | Hexagonal nut M-6         | 12                    | 12     | 12     | 12     |
| 10   | Z512929 | Panel posterior preaclarado izdo.  | Left prerinse rear panel  | 1                     | -      | 1      | -      |
| 10   | Z512928 | Panel posterior preaclarado decho. | Right prerinse rear panel | -                     | 1      | -      | 1      |
|      | Q152004 | Tornillo aplastado M-5x13          | Screw M-5x13              | 2                     | 2      | 2      | 2      |
|      | Q221342 | Remache hexagonal M-5              | Hexagonal rivet M-5       | 2                     | 2      | 2      | 2      |
| 11   | Z512963 | Soporte panel posterior            | Rear panel support        | 2                     | 2      | 2      | 2      |
|      | Q302022 | Arandela plana Ø16xØ6x1,2          | Flat washer Ø16xØ6x10.2   | 4                     | 4      | 4      | 4      |
|      | Q262040 | Arandela muelle A-6                | Spring washer A-6         | 4                     | 4      | 4      | 4      |
|      | Q162040 | Tuerca hexagonal M-6               | Hexagonal nut M-6         | 4                     | 4      | 4      | 4      |
| 12   | Z510508 | Sujeción resorte                   | Spring support            | 1                     | 1      | 1      | 1      |
|      | Q232040 | Arandela plana A-6                 | Flat washer A-6           | 2                     | 2      | 2      | 2      |
|      | Q262030 | Arandela muelle A-5                | Spring washer A-5         | 2                     | 2      | 2      | 2      |
|      | Q212031 | Tuerca sombrerete M-5              | Cowl nut M-5              | 2                     | 2      | 2      | 2      |
| 13   | Z270513 | Resorte fuerza constante           | Constant force spring     | 1                     | 1      | 1      | 1      |
|      | Q152004 | Tornillo aplastado M-5x13          | Screw M-5x13              | 1                     | 1      | 1      | 1      |
|      | Q232040 | Arandela plana A-6                 | Flat washer A-6           | 1                     | 1      | 1      | 1      |
|      | Q262030 | Arandela muelle A-5                | Spring washer A-5         | 1                     | 1      | 1      | 1      |
|      | Q212031 | Tuerca sombrerete M-5              | Cowl nut M-5              | 1                     | 1      | 1      | 1      |
| 14   | Q352001 | Pasador de aletas Ø2x15            | Cotter pin Ø2x15          | 2                     | 2      | 2      | 2      |
| 15   | Z270514 | Eje resorte                        | Spindle spring            | 1                     | 1      | 1      | 1      |
| 16   | Z510514 | Soporte resorte                    | Spring support            | 1                     | 1      | 1      | 1      |
|      | Q232040 | Arandela plana A-6                 | Flat washer A-6           | 2                     | 2      | 2      | 2      |
|      | Q262030 | Arandela muelle A-5                | Spring washer A-5         | 2                     | 2      | 2      | 2      |
|      | Q212031 | Tuerca sombrerete M-5              | Cowl nut M-5              | 2                     | 2      | 2      | 2      |



# Зип Ощепит

vsezip.ru

ZONA

MODULO DE PREACLARA

MOD.

LAVAVAJILLAS DE CINTA

+7(812)987-08-81

| ITEM | CODIGO  | DENOMINACION                       | TEXTO                            | 2700 I | 2700 D | 4000 I | 4000 D |
|------|---------|------------------------------------|----------------------------------|--------|--------|--------|--------|
| 17   | Z270512 | Encaje resorte puerta              | Door socket spring               | 2      | 2      | 2      | 2      |
| 18   | Z270531 | Sujeción puerta                    | Door fastening                   | 1      | 1      | 1      | 1      |
|      | Q152047 | Tornillo cilíndrico con cuello M-5 | Cylindrical screw with neck M-5  | 2      | 2      | 2      | 2      |
|      | Q302022 | Arandela plana Ø16xØ6x1,2          | Flat washer Ø16xØ6x10.2          | 2      | 2      | 2      | 2      |
|      | Q262030 | Arandela muelle A-5                | Spring washer A-5                | 2      | 2      | 2      | 2      |
|      | Q212031 | Tuerca sombrerete M-5              | Cowl nut M-5                     | 2      | 2      | 2      | 2      |
| 19   | Z510520 | Puerta preaclarado completa        | Complete prerinse door           | 1      | 1      | 1      | 1      |
| 20   | Z200506 | Imán puerta                        | Door magnet                      | 1      | 1      | 1      | 1      |
| 21   | Z400540 | Asa puerta completa                | Complete door handle             | 1      | 1      | 1      | 1      |
| 22   | Z511801 | Caja-cuba preaclarado completa     | Complete prerinse box-tub        | 1      | 1      | 1      | 1      |
| 23   | Z511808 | Suplemento caja preaclarado com.   | Complete prerinse box supplement | 1      | 1      | 1      | 1      |
|      | Q302022 | Arandela plana Ø16xØ6x1,2          | Flat washer Ø16xØ6x10.2          | 3      | 3      | 3      | 3      |
|      | Q262040 | Arandela muelle A-6                | Spring washer A-6                | 3      | 3      | 3      | 3      |
|      | Q162040 | Tuerca hexagonal M-6               | Hexagonal nut M-6                | 3      | 3      | 3      | 3      |
| 24   | Z510331 | Guía puerta                        | Door guide                       | 2      | 2      | 2      | 2      |
|      | Q152045 | Tornillo amarre M-6x25             | Anchoring screw M-6x25           | 16     | 16     | 16     | 16     |
|      | Q232040 | Arandela plana A-6                 | Flat washer A-6                  | 16     | 16     | 16     | 16     |
|      | Q222012 | Tuerca autoblocante M-6            | Autolock nut M-6                 | 16     | 16     | 16     | 16     |
| 25   | Z100522 | Interruptor magnético ( puerta )   | Magnetic switch ( door )         | 1      | 1      | 1      | 1      |
|      | Q242020 | Arandela abanico A-4               | Fan shaped washer A-4            | 2      | 2      | 2      | 2      |
|      | Q162020 | Tuerca hexagonal M-4               | Hexagonal nut M-4                | 2      | 2      | 2      | 2      |
| 26   | Z510808 | Bandeja preaclarado completa       | Complete prerinse plate          | 2      | 2      | 2      | 2      |
|      |         |                                    |                                  |        |        |        |        |
|      |         |                                    |                                  |        |        |        |        |
|      |         |                                    |                                  |        |        |        |        |
|      |         |                                    |                                  |        |        |        |        |
|      |         |                                    |                                  |        |        |        |        |
|      |         |                                    |                                  |        |        |        |        |
|      |         |                                    |                                  |        |        |        |        |

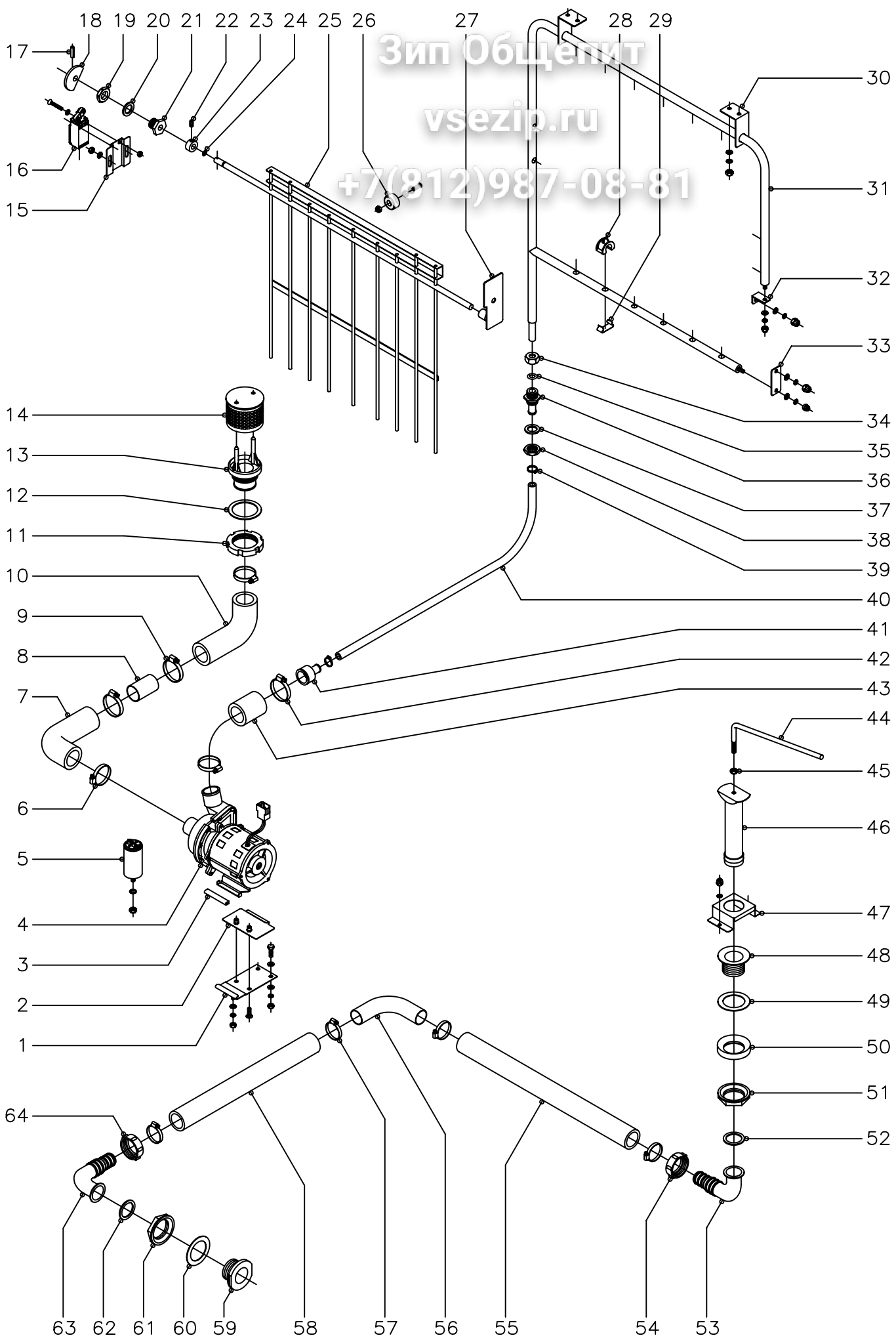

|                   |  |                 |   |             |  |
|-------------------|--|-----------------|---|-------------|--|
| N plano<br>C-1551 | Firma<br> | Fecha<br>7-2004 | Aparato<br>LAVAVAJILLAS DE CINTA<br>PARTE FUNCIONAL PREACLARADO | Lamina<br>7 | Fagor Industrial S.Coop. <b>FAGOR</b> <br>Onate |
|-------------------|--|-----------------|---|-------------|--|

# Зип Общепит

vsezip.ru

ZONA

MODULO DE PREACLARADO ( I

MOD.

LAVAVAJILLAS DE CINTA

+7(812)987-08-81

| ITEM | CODIGO  | DENOMINACION                      | TEXTO                         | 2700 I | 2700 D | 4000 I | 4000 D |
|------|---------|-----------------------------------|-------------------------------|--------|--------|--------|--------|
| 1    | Z162315 | Soporte motobomba completo        | Complete motor pump support   | 1      | 1      | 1      | 1      |
|      | Q012042 | Tornillo hexagonal M-6x15         | Hexagonal screw M-6x15        | 2      | 2      | 2      | 2      |
|      | Q302022 | Arandela plana Ø16xØ6x1,2         | Flat washer Ø16xØ6x10.2       | 5      | 5      | 5      | 5      |
|      | Q262040 | Arandela muelle A-6               | Spring washer A-6             | 3      | 3      | 3      | 3      |
|      | Q162040 | Tuerca hexagonal M-6              | Hexagonal nut M-6             | 3      | 3      | 3      | 3      |
| 2    | Z162313 | Amarre motobomba completo         | Complete motor pump anchoring | 1      | 1      | 1      | 1      |
|      | Q152004 | Tornillo aplastado M-5X13         | Screw M-5x13                  | 2      | 2      | 2      | 2      |
| 3    | Z401007 | Perfil soporte motobomba          | Motor pump support profile    | 2      | 2      | 2      | 2      |
| 4    | Z401001 | Motobomba preaclarado             | Prerinse motor pump           | 1      | 1      | 1      | 1      |
| 5    | V817100 | Condensador 6 Mf.                 | Condenser 6 Mf.               | 1      | 1      | 1      | 1      |
|      | Q261050 | Arandela muelle A-8               | Spring washer A-8             | 1      | 1      | 1      | 1      |
|      | Q162050 | Tuerca hexagonal M-8              | Hexagonal nut M-8             | 1      | 1      | 1      | 1      |
| 6    | Q881324 | Abrazadera 50 - 70                | Clamp 50 - 70                 | 2      | 2      | 2      | 2      |
| 7    | Z510932 | Conducto aspiración preaclarado   | Prerinse extraction pipe      | 1      | 1      | 1      | 1      |
| 8    | Z510933 | Casquillo preaclarado             | Prerinse bush                 | 1      | 1      | 1      | 1      |
| 9    | Q881324 | Abrazadera 50 - 70                | Clamp 50 - 70                 | 2      | 2      | 2      | 2      |
| 10   | Z510932 | Conducto aspiración preaclarado   | Prerinse extraction pipe      | 1      | 1      | 1      | 1      |
| 11   | Q228005 | Tuerca ranurada M-49X2,5          | Slotted nut M-49x20.5         | 1      | 1      | 1      | 1      |
| 12   | Q307059 | Arandela junta Ø72xØ56x2          | Joint washer Ø72xØ56x2        | 1      | 1      | 1      | 1      |
| 13   | Z600905 | Pasamuros aspiración              | Extractor wire protection     | 1      | 1      | 1      | 1      |
| 14   | Z600906 | Filtro aspiración                 | Extractor filter              | 1      | 1      | 1      | 1      |
| 15   | Z511231 | Soporte micro aclarado            | Micro rinse support           | 1      | 1      | 1      | 1      |
|      | Q232040 | Arandela plana A-6                | Flat washer A-6               | 2      | 2      | 2      | 2      |
|      | Q222012 | Tuerca hexagonal autoblocante M-6 | Autolocking hexagonal nut M-6 | 2      | 2      | 2      | 2      |
| 16   | Z513007 | Final de carrera (Micro aclarado) | End of run (Micro rinse)      | 1      | 1      | 1      | 1      |
|      | Q152026 | Tornillo avellanado M-4x35        | Countersunk screw M-4x35      | 2      | 2      | 2      | 2      |
|      | Q242020 | Arandela abanico A-4              | Fan shaped washer A-4         | 2      | 2      | 2      | 2      |
|      | Q162020 | Tuerca hexagonal M-4              | Hexagonal nut M-4             | 2      | 2      | 2      | 2      |
| 17   | Q371031 | Manguito sujeción Ø3x20           | Fastening socket Ø3x20        | 1      | 1      | 1      | 1      |

# Зип Общепит

vsezip.ru

ZONA

MODULO DE PREACLARADO (

MOD.

LAVAVAJILLAS DE CINTA

+7(812)987-08-81

| ITEM | CODIGO  | DENOMINACION                      | TEXTO                         | 2700 I | 2700 D | 4000 I | 4000 D |
|------|---------|-----------------------------------|-------------------------------|--------|--------|--------|--------|
| 18   | Z511209 | Leva                              | Cam                           | 1      | 1      | 1      | 1      |
| 19   | Q223023 | Tuerca hexagonal 5/8"             | Hexagonal nut 5/8"            | 1      | 1      | 1      | 1      |
| 20   | Q307032 | Arandela junta Ø32xØ21x3          | Joint washer Ø32xØ21x3        | 1      | 1      | 1      | 1      |
| 21   | Z511201 | Casquillo roscado 5/8"            | Threaded bush 5/8"            | 1      | 1      | 1      | 1      |
| 22   | Q132041 | Varilla roscada M-6x10            | Threaded rod M-6x10           | 1      | 1      | 1      | 1      |
| 23   | Z511208 | Tope eje accionador               | Actuator spindle buffer       | 1      | 1      | 1      | 1      |
| 24   | Q307070 | Junta tórica Ø12,74xØ7,5xØ2,62    | "O" ring Ø12,74xØ7,5xØ2,62    | 1      | 1      | 1      | 1      |
| 25   | Z511202 | Accionador aclarado izquierdo     | Left rinse actuator           | 1      | -      | 1      | -      |
| 25   | Z511221 | Accionador aclarado derecho       | Right rinse actuator          | -      | 1      | -      | 1      |
| 26   | Z510342 | Tope accionador aclarado          | Rinse actuator buffer         | 1      | 1      | 1      | 1      |
|      | Q152013 | Perno soldado M-6x30              | Welded bolt M-6x30            | 1      | 1      | 1      | 1      |
|      | Q162040 | Tuerca hexagonal M-6              | Hexagonal nut M-6             | 1      | 1      | 1      | 1      |
|      | Q222012 | Tuerca hexagonal autoblocante M-6 | Autolocking hexagonal nut M-6 | 1      | 1      | 1      | 1      |
| 27   | -       | Soporte-casquillo derecho comp.   | Complete right bush support.  | 1      | -      | 1      | -      |
| 27   | -       | Soporte-casquillo izquierdo comp. | Complete left bush support.   | -      | 1      | -      | 1      |
| 28   | Z311831 | Tobera preaclarado                | Prerinse nozzle               | 16     | 16     | 16     | 16     |
| 29   | Z400711 | Enganche tobera preaclarado       | Prerinse nozzle hook          | 16     | 16     | 16     | 16     |
| 30   | Z511925 | Amarre superior preaclarado "A"   | Upper anchoring prerinse "A"  | 2      | 2      | 2      | 2      |
|      | Q302022 | Arandela plana Ø16xØ6x1,2         | Flat washer Ø16xØ6x10.2       | 4      | 4      | 4      | 4      |
|      | Q262040 | Arandela muelle A-6               | Spring washer A-6             | 4      | 4      | 4      | 4      |
|      | Q162040 | Tuerca hexagonal M-6              | Hexagonal nut M-6             | 4      | 4      | 4      | 4      |
| 31   | Z511921 | Árbol preaclarado completo        | Complete prerinse arbour      | 1      | 1      | 1      | 1      |
|      | Q232040 | Arandela plana A-6                | Flat washer A-6               | 2      | 2      | 2      | 2      |
|      | Q262030 | Arandela muelle A-5               | Spring washer A-5             | 2      | 2      | 2      | 2      |
|      | Q212031 | Tuerca sombrerete M-5             | Cowl nut M-5                  | 2      | 2      | 2      | 2      |
| 32   | Z511926 | Sujeción superior preaclarado "B" | Prerinse upper fastening "B"  | 1      | 1      | 1      | 1      |
|      | Q232040 | Arandela plana A-6                | Flat washer A-6               | 1      | 1      | 1      | 1      |
|      | Q262040 | Arandela muelle A-6               | Spring washer A-6             | 1      | 1      | 1      | 1      |
|      | Q212040 | Tuerca sombrerete M-6             | Cowl nut M-6                  | 1      | 1      | 1      | 1      |

# Зип Общепит

vsezip.ru

ZONA

+7(812)987-08-81

| MOD. |         | LAVAVAJILLAS DE CINTA              |                                 | MODULO DE PREACLARADO ( I |        |        |        |
|------|---------|------------------------------------|---------------------------------|---------------------------|--------|--------|--------|
| ITEM | CODIGO  | DENOMINACION                       | TEXTO                           | 2700 I                    | 2700 D | 4000 I | 4000 D |
| 33   | Z511907 | Sujeción rama inferior preaclarado | Prerinse lower branch fastening | 1                         | 1      | 1      | 1      |
|      | Q232040 | Arandela plana A-6                 | Flat washer A-6                 | 1                         | 1      | 1      | 1      |
|      | Q262040 | Arandela muelle A-6                | Spring washer A-6               | 1                         | 1      | 1      | 1      |
|      | Q212040 | Tuerca sombrerete M-6              | Cowl nut M-6                    | 1                         | 1      | 1      | 1      |
| 34   | Q223108 | Tuerca M-24x2,5                    | Nut M-24x20.5                   | 1                         | 1      | 1      | 1      |
| 35   | Q307063 | Junta tórica Ø19,35xØ12,29xØ3,53   | "O" ring Ø19,35xØ12,29xØ30.53   | 1                         | 1      | 1      | 1      |
| 36   | Z281901 | Pasamuros aclarado                 | Rinse wire protection           | 1                         | 1      | 1      | 1      |
| 37   | Q307032 | Arandela junta Ø32xØ21x3           | Joint washer Ø32xØ21x3          | 1                         | 1      | 1      | 1      |
| 38   | Q223023 | Tuerca hexagonal 5/8"              | Hexagonal nut 5/8"              | 1                         | 1      | 1      | 1      |
| 39   | Q881336 | Abrazadera 16 - 27                 | Clamp 16 - 27                   | 2                         | 2      | 2      | 2      |
| 40   | 3715300 | Tubo de goma Ø24xØ14x800           | Rubber pipe Ø24xØ14x800         | 1                         | 1      | 1      | 1      |
| 41   | Z162312 | Reducción                          | Reduction                       | 1                         | 1      | 1      | 1      |
| 42   | Q881324 | Abrazadera 50 - 70                 | Clamp 50 - 70                   | 2                         | 2      | 2      | 2      |
| 43   | Z162301 | Conducto impulsión                 | Impulse pipe                    | 1                         | 1      | 1      | 1      |
| 44   | Z510924 | Asa aliviadero preaclarado         | Prerinse overflow handle        | 1                         | 1      | 1      | 1      |
| 45   | Q162050 | Tuerca hexagonal M-8               | Hexagonal nut M-8               | 1                         | 1      | 1      | 1      |
| 46   | Z510921 | Aliviadero preaclarado soldado     | Welded prerinse overflow        | 1                         | 1      | 1      | 1      |
| 47   | Z510941 | Guía aliviadero preaclarado        | Prerinse overflow guide         | 1                         | 1      | 1      | 1      |
|      | Q262040 | Arandela muelle A-6                | Spring washer A-6               | 2                         | 2      | 2      | 2      |
|      | Q212040 | Tuerca sombrerete M-6              | Cowl nut M-6                    | 2                         | 2      | 2      | 2      |
| 48   | Z102104 | Válvula desagüe                    | Drainage valve                  | 1                         | 1      | 1      | 1      |
| 49   | Q307009 | Arandela junta Ø70xØ48x1,5         | Joint washer Ø70xØ48x10.5       | 1                         | 1      | 1      | 1      |
| 50   | Q307026 | Junta especial                     | Special joint                   | 1                         | 1      | 1      | 1      |
| 51   | Z702101 | Tuerca rosca 1 1/2"                | Nut thread 1 1/2"               | 1                         | 1      | 1      | 1      |
| 52   | Q307027 | Arandela junta Ø45xØ35x2           | Joint washer Ø45xØ35x2          | 1                         | 1      | 1      | 1      |
| 53   | Z602101 | Codo desagüe                       | Drainage elbow                  | 1                         | 1      | 1      | 1      |
| 54   | Z602102 | Tuerca                             | Nut                             | 1                         | 1      | 1      | 1      |
| 55   | Z510934 | Manguera comunicación preaclaclar. | Prerinse connection pipe        | 1                         | 1      | 1      | 1      |
| 56   | Z310932 | Codo empalme                       | Elbow joint                     | 1                         | 1      | 1      | 1      |

# Зип Ощепит

vsezip.ru

ZONA

MODULO DE PREACLARADO ( P

MOD.

LAVAVAJILLAS DE CINTA

+7(812)987-08-81

| ITEM | CODIGO  | DENOMINACION               | TEXTO                     | 2700 I | 2700 D | 4000 I | 4000 D |
|------|---------|----------------------------|---------------------------|--------|--------|--------|--------|
| 57   | Q881307 | Abrazadera 40 - 60         | Clamp 40 - 60             | 4      | 4      | 4      | 4      |
| 58   | Z310912 | Manguera comunicación      | Connection pipe           | 1      | 1      | 1      | 1      |
| 59   | Z510931 | Pasamuros                  | Wire protection           | 1      | 1      | 1      | 1      |
| 60   | Q307009 | Arandela junta Ø70xØ48x1,5 | Joint washer Ø70xØ48x10.5 | 1      | 1      | 1      | 1      |
| 61   | Z702101 | Tuerca R-1 1/2"            | Nut R-1 1/2"              | 1      | 1      | 1      | 1      |
| 62   | Q307027 | Arandela junta Ø45xØ35x2   | Joint washer Ø45xØ35x2    | 1      | 1      | 1      | 1      |
| 63   | Z602101 | Codo desagüe               | Drainage elbow            | 1      | 1      | 1      | 1      |
| 64   | Z602102 | Tuerca                     | Nut                       | 1      | 1      | 1      | 1      |
|      |         |                            |                           |        |        |        |        |
|      |         |                            |                           |        |        |        |        |
|      |         |                            |                           |        |        |        |        |
|      |         |                            |                           |        |        |        |        |
|      |         |                            |                           |        |        |        |        |
|      |         |                            |                           |        |        |        |        |
|      |         |                            |                           |        |        |        |        |
|      |         |                            |                           |        |        |        |        |
|      |         |                            |                           |        |        |        |        |
|      |         |                            |                           |        |        |        |        |
|      |         |                            |                           |        |        |        |        |
|      |         |                            |                           |        |        |        |        |
|      |         |                            |                           |        |        |        |        |
|      |         |                            |                           |        |        |        |        |
|      |         |                            |                           |        |        |        |        |
|      |         |                            |                           |        |        |        |        |
|      |         |                            |                           |        |        |        |        |
|      |         |                            |                           |        |        |        |        |

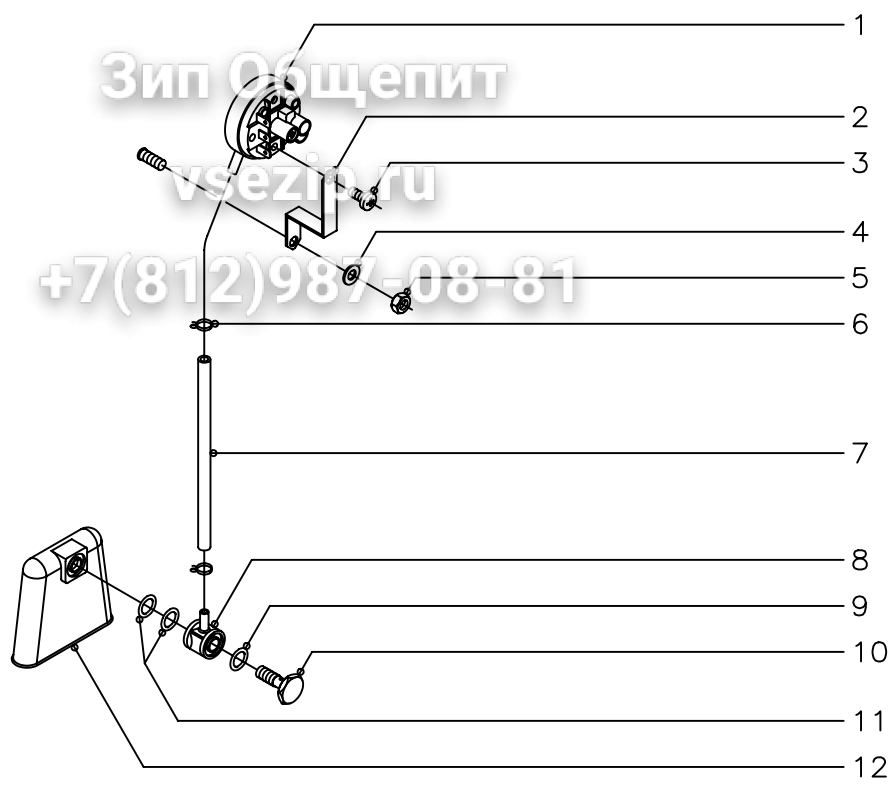

Зип Общепит

vsezip.ru

+7(812)987-08-81

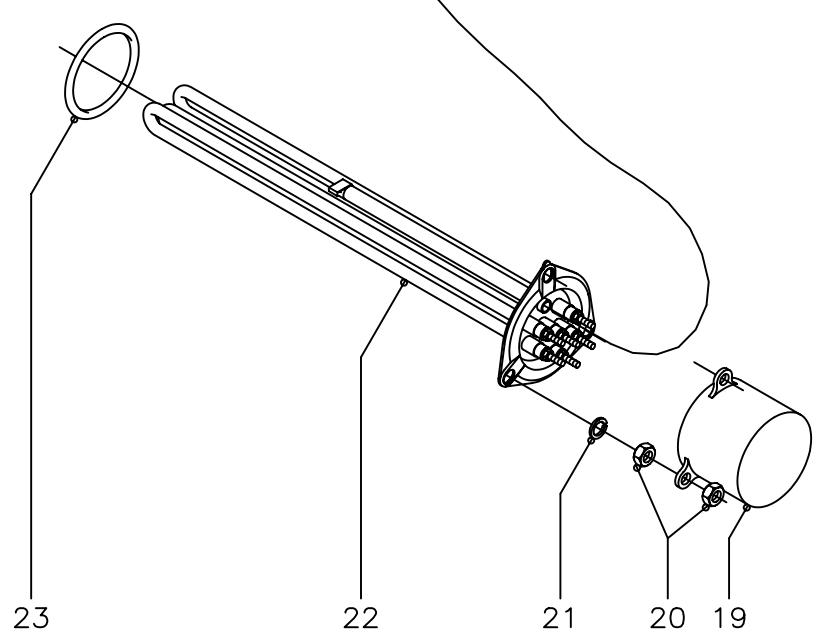
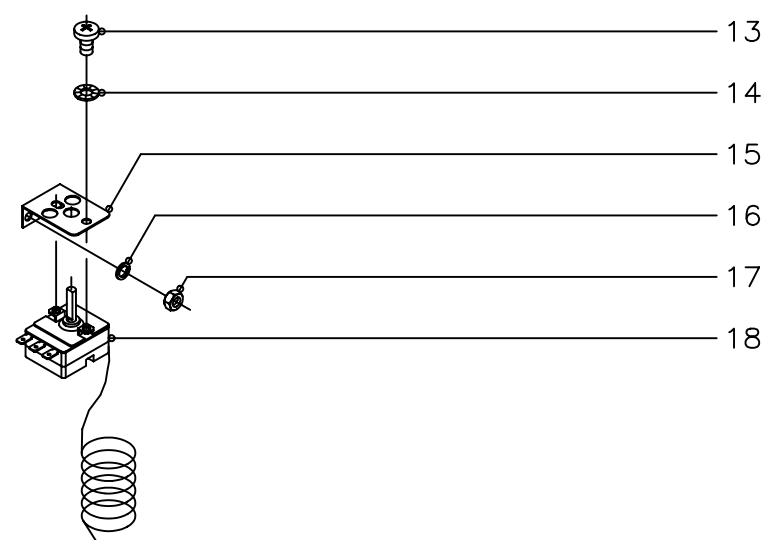

|                   |           |                 |   |             |  |
|-------------------|-----------|-----------------|---|-------------|--|
| N plano<br>C-1552 | Firma<br> | Fecha<br>7-2004 | Aparato<br>LAVAVAJILLAS DE CINTA<br>NIVELES Y CALENTAMIENTO PREAclarado | Lamina<br>8 | Fagor Industrial S.Coop. <b>FAGOR</b><br>Onate |
|-------------------|-----------|-----------------|---|-------------|--|

# Зип Общепит

vsezip.ru

ZONA

MODULO DE PREACLARADO ( Nivel

MOD.

LAVAVAJILLAS DE CINTA

+7(812)987-08-81

| ITEM | CODIGO  | DENOMINACION                     | TEXTO                         | 2700 I | 2700 D | 4000 I | 4000 D |
|------|---------|----------------------------------|-------------------------------|--------|--------|--------|--------|
| 1    | Z313006 | Presostato simple                | Simple pressostat             | 1      | 1      | 1      | 1      |
| 2    | P503068 | Soporte presostato               | Pressostat support            | 1      | 1      | 1      | 1      |
| 3    | Q082032 | Tornillo alomado BZ-3,5x9,5      | Curved screw BZ-3.5x90.5      | 1      | 1      | 1      | 1      |
| 4    | Q232040 | Arandela plana A-6               | Flat washer A-6               | 1      | 1      | 1      | 1      |
| 5    | Q162040 | Tuerca hexagonal M-6             | Hexagonal nut M-6             | 1      | 1      | 1      | 1      |
| 6    | P102154 | Brida elástica                   | Elastic yoke                  | 2      | 2      | 2      | 2      |
| 7    | 3702400 | Tubo de goma Ø 8x4x130           | Rubber pipe Ø 8x4x130         | 1      | 1      | 1      | 1      |
| 8    | Z203012 | Empalme presostato               | Pressostat joint              | 1      | 1      | 1      | 1      |
| 9    | Q307003 | Junta tórica Ø16,01xØ10,77xØ2,62 | "O" ring Ø16,01xØ10,77xØ20.62 | 1      | 1      | 1      | 1      |
| 10   | Z203013 | Tornillo presostato              | Pressostat screw              | 1      | 1      | 1      | 1      |
| 11   | Q307003 | Junta tórica Ø16,01xØ10,77xØ2,62 | "O" ring Ø16,01xØ10,77xØ20.62 | 2      | 2      | 2      | 2      |
| 12   | Z203011 | Cámara presostato                | Pressostat chamber            | 1      | 1      | 1      | 1      |
| 13   | Q152024 | Tornillo avellanado M-4x8        | Countersunk screw M-4x8       | 2      | 2      | 2      | 2      |
| 14   | Q242020 | Arandela abanico A-4             | Fan shaped washer A-4         | 2      | 2      | 2      | 2      |
| 15   | Z850111 | Soporte termostato               | Thermostat support            | 1      | 1      | 1      | 1      |
| 16   | Q232040 | Arandela plana A-6               | Flat washer A-6               | 2      | 2      | 2      | 2      |
| 17   | Q162040 | Tuerca hexagonal M-6             | Hexagonal nut M-6             | 2      | 2      | 2      | 2      |
| 18   | Z203014 | Termostato                       | Thermostat                    | 1      | 1      | 1      | 1      |
| 19   | Z101723 | Caperuza resistencia             | Resistor cap                  | 2      | 2      | 2      | 2      |
| 20   | Q163140 | Tuerca hexagonal M-6 LATÓN       | Brass hexagonal nut M-6       | 12     | 12     | 12     | 12     |
| 21   | Q262040 | Arandela muelle A-6              | Spring washer A-6             | 6      | 6      | 6      | 6      |
| 22   | Z313601 | Resistencia 230 V., 5.000 W.     | Resistance 230 V., 5,000 W.   | 2      | 2      | 2      | 2      |
| 23   | Q307044 | Junta tórica Ø67,18xØ56,52xØ5,30 | "O" ring Ø67,18xØ56,52xØ50.30 | 2      | 2      | 2      | 2      |
|      |         |                                  |                               |        |        |        |        |
|      |         |                                  |                               |        |        |        |        |
|      |         |                                  |                               |        |        |        |        |
|      |         |                                  |                               |        |        |        |        |
|      |         |                                  |                               |        |        |        |        |
|      |         |                                  |                               |        |        |        |        |



Зип Общепит

vsezip.ru

+7(812)987-08-81

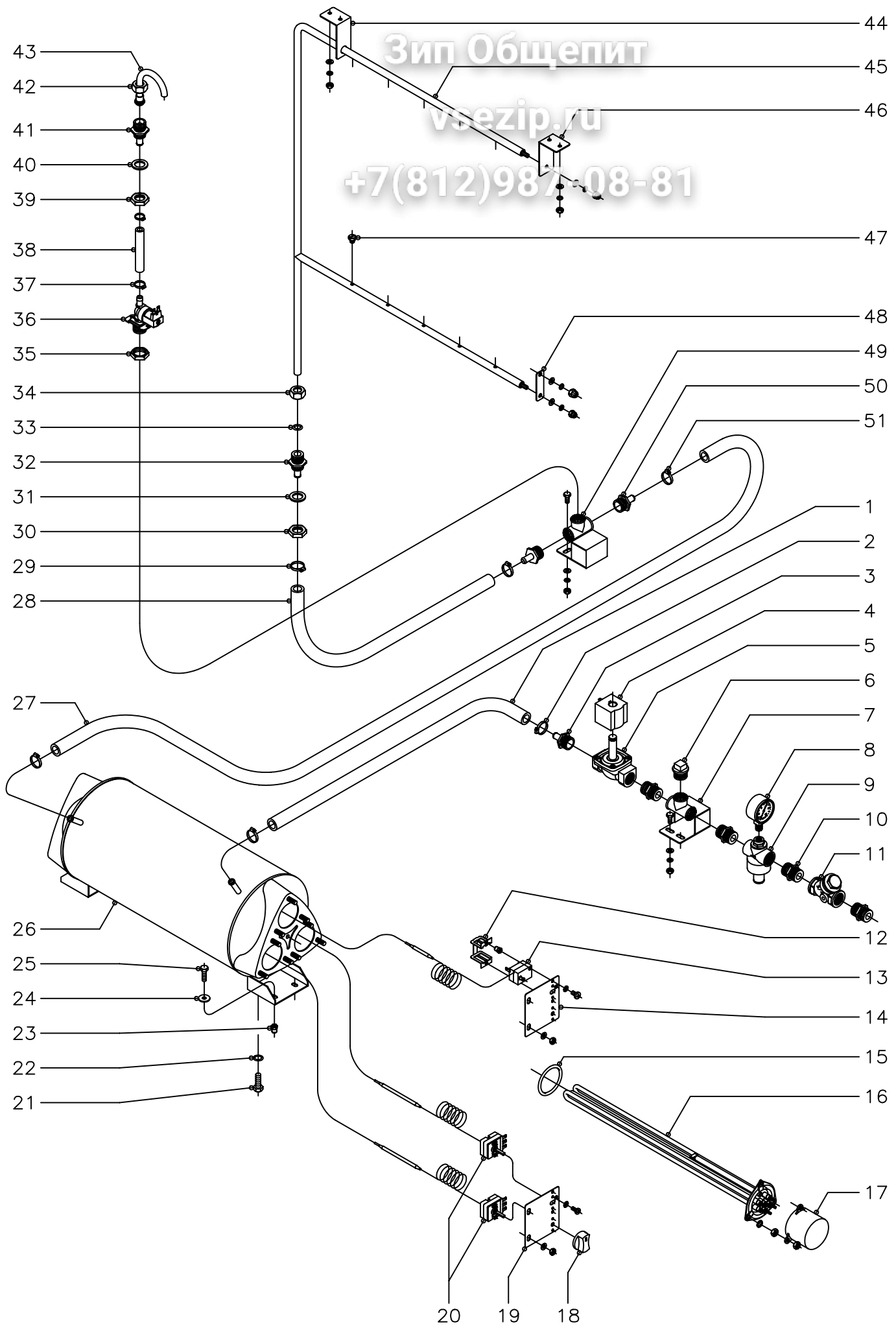

# Зип Общепит

vsezip.ru

ZONA

PARTE FUNCIONAL ACL

MOD.

LAVAVAJILLAS DE CINTA

+7(812)987-08-81

| ITEM | CODIGO  | DENOMINACION                   | TEXTO                        | FI-2700 | FI-4000 | FI-6000 |  |
|------|---------|--------------------------------|------------------------------|---------|---------|---------|--|
| 1    | 3715300 | Tubo de goma Ø24xØ14x800       | Rubber pipe Ø24xØ14x800      | 1       | 1       | 1       |  |
| 2    | Q881336 | Abrazadera 27 - 16             | Clamp 27 - 16                | 2       | 2       | 2       |  |
| 3    | Z316419 | Empalme 3/4"                   | Joint 3/4"                   | 1       | 1       | 1       |  |
| 4    | Z102323 | Bobina para electroválvula     | Coil for electrovalve        | 1       | 1       | 1       |  |
| 5    | Z102305 | Electrovalvula 3/4"            | Electrovalve 3/4"            | 1       | 1       | 1       |  |
| 6    | Z311103 | Tapón 3/4"                     | Lid 3/4"                     | 1       | 1       | 1       |  |
| 7    | Z311101 | Te-soporte completo            | Complete T support           | 1       | 1       | 1       |  |
|      | Q012042 | Tornillo hexagonal M-6x15      | Hexagonal screw M-6x15       | 2       | 2       | 2       |  |
|      | Q302022 | Arandela plana Ø16xØ6x1,2      | Flat washer Ø16xØ6x10.2      | 2       | 2       | 2       |  |
|      | Q262040 | Arandela muelle A-6            | Spring washer A-6            | 2       | 2       | 2       |  |
|      | Q162040 | Tuerca hexagonal M-6           | Hexagonal nut M-6            | 2       | 2       | 2       |  |
| 8    | Z102316 | Manómetro                      | Pressure gauge               | 1       | 1       | 1       |  |
| 9    | Z102307 | Reductor de presión            | Pressure reducer             | 1       | 1       | 1       |  |
| 10   | Z102301 | Manguito 3/4"                  | Socket 3/4"                  | 4       | 4       | 4       |  |
| 11   | Z102308 | Filtro 3/4"                    | Filter 3/4"                  | 1       | 1       | 1       |  |
| 12   | Z203060 | Amarre limitador Tecasa        | Tecasa limiter anchoring     | 1       | 1       | 1       |  |
|      | Q221341 | Remache hexagonal M-4          | Hexagonal rivet M-4          | 2       | 2       | 2       |  |
|      | Q152024 | Tornillo avellanado M-4x8      | Countersunk screw M-4x8      | 2       | 2       | 2       |  |
| 13   | Z213014 | Termostato limitador Tecasa    | Tecasa limiter thermostat    | 1       | 1       | 1       |  |
| 14   | Z273037 | Soporte termostatos            | Thermostat supports          | 1       | 1       | 1       |  |
|      | Q302022 | Arandela plana Ø16xØ6x1,2      | Flat washer Ø16xØ6x10.2      | 2       | 2       | 2       |  |
|      | Q162040 | Tuerca hexagonal M-6           | Hexagonal nut M-6            | 2       | 2       | 2       |  |
| 15   | Q307044 | Junta tórica Ø67,18xØ56,52x5,3 | O" ring Ø67,18xØ56,52xØ500.3 | 3       | 3       | 3       |  |
| 16   | Z129502 | Resistencia 230 V., 12.000 W.  | Resistance 230 V., 12,000 W. | 3       | 3       | 3       |  |
| 17   | Z101723 | Caperuza resistencia           | Resistor cap                 | 3       | 3       | 3       |  |
|      | Q262040 | Arandela muelle A-6            | Spring washer A-6            | 9       | 9       | 9       |  |
|      | Q163140 | Tuerca hexagonal M-6 latón     | Brass hexagonal nut M-6      | 18      | 18      | 18      |  |
| 18   | R663062 | Botón de mando completo        | Complete control button      | 1       | 1       | 1       |  |
| 19   | Z273037 | Soporte termostatos            | Thermostat support           | 1       | 1       | 1       |  |

# Зип Общепит

vsezip.ru

ZONA

+7(812)987-08-81

| MOD. |         | LAVAVAJILLAS DE CINTA              | ZONA                            |         | PARTE FUNCIONAL ACLA |         |  |  |
|------|---------|------------------------------------|---------------------------------|---------|----------------------|---------|--|--|
| ITEM | CODIGO  | DENOMINACION                       | TEXTO                           | FI-2700 | FI-4000              | FI-6000 |  |  |
|      | Q302022 | Arandela plana Ø16xØ6x1,2          | Flat washer Ø16xØ6x10.2         | 2       | 2                    | 2       |  |  |
|      | Q162040 | Tuerca hexagonal M-6               | Hexagonal nut M-6               | 2       | 2                    | 2       |  |  |
| 20   | Z203014 | Termostato calderin                | Wash drum thermostat            | 2       | 2                    | 2       |  |  |
|      | Q152024 | Tornillo avellanado M-4x8          | Countersunk screw M-4x8         | 2       | 2                    | 2       |  |  |
| 21   | Q012063 | Tornillo hexagonal M-10x20         | Hexagonal screw M-10x20         | 1       | 1                    | 1       |  |  |
| 22   | Q307048 | Junta tórica Ø16,18xØ9,12xØ3,53    | "O" ring Ø16,18xØ9,12xØ30.53    | 1       | 1                    | 1       |  |  |
| 23   | Q221343 | Remache hexagonal M-6              | Hexagonal rivet M-6             | 4       | 4                    | 4       |  |  |
| 24   | Q302022 | Arandela plana Ø16xØ6x1,2          | Flat washer Ø16xØ6x10.2         | 4       | 4                    | 4       |  |  |
| 25   | Q012042 | Tornillo hexagonal M-6x15          | Hexagonal screw M-6x15          | 4       | 4                    | 4       |  |  |
| 26   | Z316426 | Cuerpo calderin completo           | Complete wash drum body         | 1       | 1                    | 1       |  |  |
| 27   | 3715300 | Tubo de goma Ø24xØ14x1.100         | Rubber pipe Ø24xØ14x1.100       | 1       | 1                    | 1       |  |  |
| 28   | 3715300 | Tubo de goma Ø24xØ14x1.100         | Rubber pipe Ø24xØ14x1.100       | 1       | 1                    | 1       |  |  |
| 29   | Q881336 | Abrazadera 27 - 16                 | Clamp 27 - 16                   | 2       | 2                    | 2       |  |  |
| 30   | Q223023 | Tuerca hexagonal 5/8"              | Hexagonal nut 5/8"              | 1       | 1                    | 1       |  |  |
| 31   | Q307032 | Arandela junta Ø32xØ21x3           | Joint washer Ø32xØ21x3          | 1       | 1                    | 1       |  |  |
| 32   | Z281901 | Pasamuros aclarado                 | Rinse wire protection           | 1       | 1                    | 1       |  |  |
| 33   | Q307063 | Junta tórica Ø19,35xØ12,29xØ3,53   | "O" ring Ø19,35xØ12,29xØ30.53   | 1       | 1                    | 1       |  |  |
| 34   | Q223108 | Tuerca M-24x2,5                    | Nut M-24x20.5                   | 1       | 1                    | 1       |  |  |
| 35   | Q221324 | Tuerca hexagonal 3/4" gas          | Hexagonal nut 3/4" gas          | 1       | 1                    | 1       |  |  |
| 36   | Z701135 | Electroválvula entrada agua simple | Simple water inlet electrovalve | 1       | 1                    | 1       |  |  |
| 37   | Q881302 | Abrazadera 12 - 20                 | Clamp 12 - 20                   | 2       | 2                    | 2       |  |  |
| 38   | 3676900 | Tubo de goma Ø17xØ10x1.700         | Rubber pipe Ø17xØ10x1.700       | 1       | 1                    | 1       |  |  |
| 39   | Q223023 | Tuerca hexagonal 5/8"              | Hexagonal nut 5/8"              | 1       | 1                    | 1       |  |  |
| 40   | Q307032 | Arandela junta Ø32xØ21x3           | Joint washer Ø32xØ21x3          | 1       | 1                    | 1       |  |  |
| 41   | Z821910 | Pasamuros conducto llenado         | Filling pipe wire protection    | 1       | 1                    | 1       |  |  |
| 42   | Q223106 | Tuerca unión conducto              | Pipe nut joint                  | 1       | 1                    | 1       |  |  |
| 43   | Z331101 | Conducto de llenado                | Filling pipe                    | 1       | 1                    | 1       |  |  |
| 44   | Z511905 | Amarre superior aclarado "A"       | Upper anchoring rinse "A"       | 1       | 1                    | 1       |  |  |
|      | Q302022 | Arandela plana Ø16xØ6x1,2          | Flat washer Ø16xØ6x10.2         | 2       | 2                    | 2       |  |  |

# Зип Общепит

vsezip.ru

+7(812)987-08-81

| MOD. |         | LAVAVAJILLAS DE CINTA           |                              | ZONA    | PARTE FUNCIONAL ACLARADO |         |  |  |
|------|---------|---------------------------------|------------------------------|---------|--------------------------|---------|--|--|
| ITEM | CODIGO  | DENOMINACION                    | TEXTO                        | FI-2700 | FI-4000                  | FI-6000 |  |  |
|      | Q262040 | Arandela muelle A-6             | Spring washer A-6            | 2       | 2                        | 2       |  |  |
|      | Q162040 | Tuerca hexagonal M-6            | Hexagonal nut M-6            | 2       | 2                        | 2       |  |  |
| 45   | Z511901 | Árbol aclarado completo         | Complete rinse arbour        | 1       | 1                        | 1       |  |  |
|      | Q232040 | Arandela plana A-6              | Flat washer A-6              | 2       | 2                        | 2       |  |  |
|      | Q262030 | Arandela muelle A-5             | Spring washer A-5            | 2       | 2                        | 2       |  |  |
|      | Q212031 | Tuerca sombrerete M-5           | Cowl nut M-5                 | 2       | 2                        | 2       |  |  |
| 46   | Z511906 | Amarre superior aclarado "B"    | Upper anchoring rinse "B"    | 1       | 1                        | 1       |  |  |
|      | Q302022 | Arandela plana Ø16xØ6x1,2       | Flat washer Ø16xØ6x10.2      | 2       | 2                        | 2       |  |  |
|      | Q262040 | Arandela muelle A-6             | Spring washer A-6            | 2       | 2                        | 2       |  |  |
|      | Q162040 | Tuerca hexagonal M-6            | Hexagonal nut M-6            | 2       | 2                        | 2       |  |  |
| 47   | Z211903 | Tobera de aclarado              | Rinse nozzle                 | 10      | 10                       | 10      |  |  |
| 48   | Z511907 | Sujeción rama inferior aclarado | Rinse lower branch fastening | 1       | 1                        | 1       |  |  |
|      | Q232040 | Arandela plana A-6              | Flat washer A-6              | 1       | 1                        | 1       |  |  |
|      | Q262040 | Arandela muelle A-6             | Spring washer A-6            | 1       | 1                        | 1       |  |  |
|      | Q212040 | Tuerca sombrerete M-6           | Cowl nut M-6                 | 1       | 1                        | 1       |  |  |
| 49   | Z311101 | Te-soporte completo             | Complete T support           | 1       | 1                        | 1       |  |  |
|      | Q012042 | Tornillo hexagonal M-6x15       | Hexagonal screw M-6x15       | 2       | 2                        | 2       |  |  |
|      | Q302022 | Arandela plana Ø16xØ6x1,2       | Flat washer Ø16xØ6x10.2      | 2       | 2                        | 2       |  |  |
|      | Q262040 | Arandela muelle A-6             | Spring washer A-6            | 2       | 2                        | 2       |  |  |
|      | Q162040 | Tuerca hexagonal M-6            | Hexagonal nut M-6            | 2       | 2                        | 2       |  |  |
| 50   | Z316419 | Empalme 3/4"                    | Joint 3/4"                   | 2       | 2                        | 2       |  |  |
| 51   | Q881336 | Abrazadera 27 - 16              | Clamp 27 - 16                | 2       | 2                        | 2       |  |  |
|      |         |                                 |                              |         |                          |         |  |  |
|      |         |                                 |                              |         |                          |         |  |  |
|      |         |                                 |                              |         |                          |         |  |  |
|      |         |                                 |                              |         |                          |         |  |  |
|      |         |                                 |                              |         |                          |         |  |  |
|      |         |                                 |                              |         |                          |         |  |  |

Зип Общепит

vsezip.ru

+7(812)987-08-81

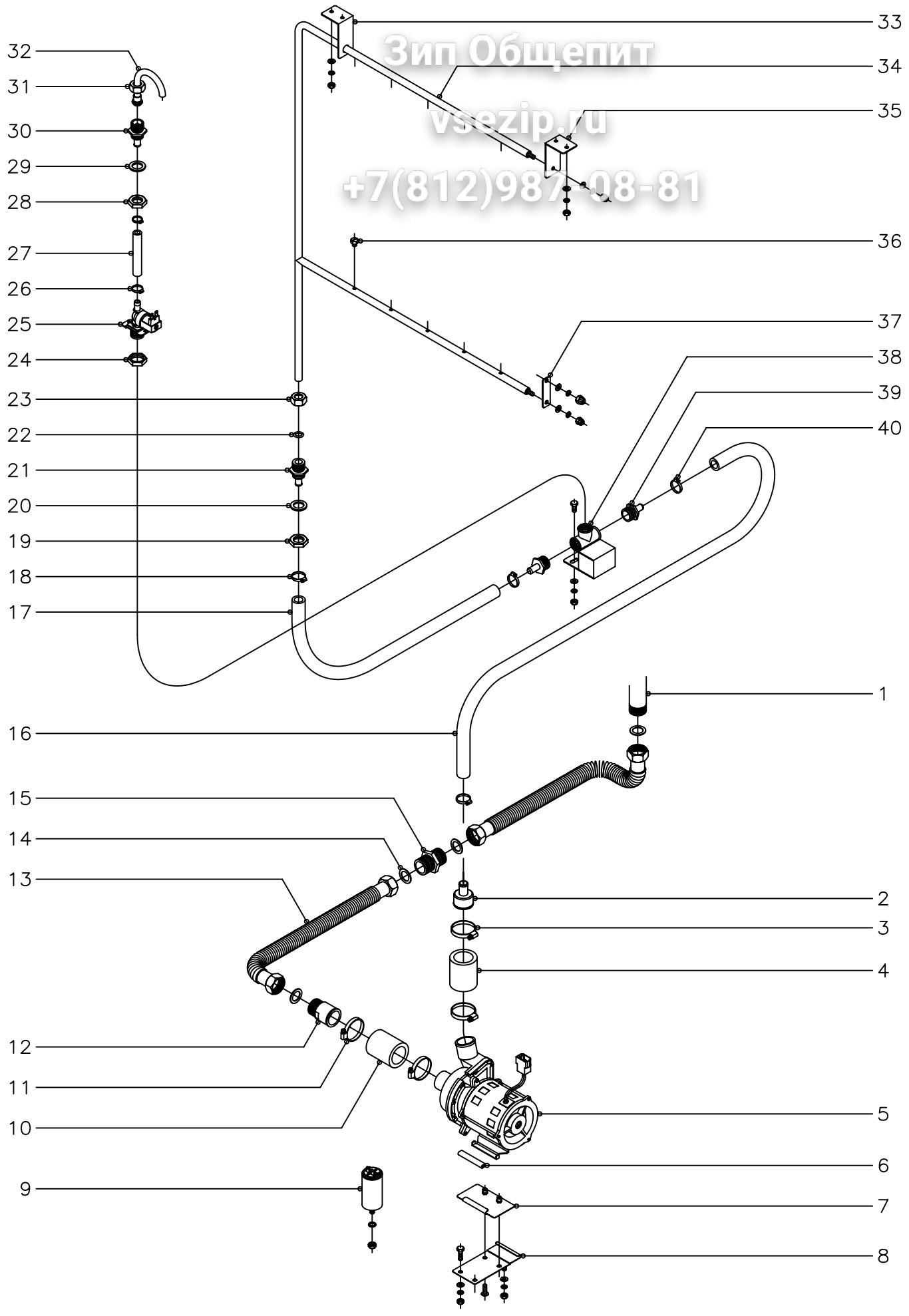

|                   |           |                 |  |              |  |
|-------------------|-----------|-----------------|--|--------------|--|
| N plano<br>C-1554 | Firma<br> | Fecha<br>7-2004 | Aparato<br>LAVAJILLAS DE CINTA (ECO)<br>PARTE FUNCIONAL ACLARADO | Lamina<br>10 | Fagor Industrial S.Coop. <b>FAGOR</b><br>Onate |
|-------------------|-----------|-----------------|--|--------------|--|

# Зип Общепит

vsezip.ru

+7(812)987-08-81

| MOD. |         | LAVAVAJILLAS DE CINTA             |                               | ZONA     | PARTE FUNCIONAL ACLAR |          |  |  |
|------|---------|-----------------------------------|-------------------------------|----------|-----------------------|----------|--|--|
| ITEM | CODIGO  | DENOMINACION                      | TEXTO                         | ECO-2700 | ECO-4000              | ECO-6000 |  |  |
| 1    | -       | Salida de generador agua caliente | Hot water generator outlet    | 1        | 1                     | 1        |  |  |
| 2    | Z162312 | Reducción                         | Reduction                     | 1        | 1                     | 1        |  |  |
| 3    | Q881324 | Abrazadera 50 - 70                | Clamp 50 - 70                 | 2        | 2                     | 2        |  |  |
| 4    | Z162301 | Conducto aspiración - impulsión   | Extractor pipe - impulse      | 1        | 1                     | 1        |  |  |
| 5    | Z401001 | Motobomba de aclarado             | Rinse motor pump              | 1        | 1                     | 1        |  |  |
| 6    | Z401007 | Perfil soporte motobomba          | Motor pump support profile    | 2        | 2                     | 2        |  |  |
| 7    | Z162313 | Amarre motobomba completo         | Complete motor pump anchoring | 1        | 1                     | 1        |  |  |
|      | Q152004 | Tornillo aplastado M-5x13         | Screw M-5x13                  | 2        | 2                     | 2        |  |  |
| 8    | Z162315 | Soporte motobomba completo        | Complete motor pump support   | 1        | 1                     | 1        |  |  |
|      | Q012042 | Tornillo hexagonal M-6x15         | Hexagonal screw M-6x15        | 2        | 2                     | 2        |  |  |
|      | Q302022 | Arandela plana Ø16xØ6x1,2         | Flat washer Ø16xØ6x10.2       | 5        | 5                     | 5        |  |  |
|      | Q262040 | Arandela muelle A-6               | Spring washer A-6             | 3        | 3                     | 3        |  |  |
|      | Q162040 | Tuerca hexagonal M-6              | Hexagonal nut M-6             | 3        | 3                     | 3        |  |  |
| 9    | V817100 | Condensador 6 Mf.                 | Condensor 6 Mf.               | 1        | 1                     | 1        |  |  |
|      | Q261050 | Arandela muelle A-8               | Spring washer A-8             | 1        | 1                     | 1        |  |  |
|      | Q162050 | Tuerca hexagonal M-8              | Hexagonal nut M-8             | 1        | 1                     | 1        |  |  |
| 10   | Z162301 | Conducto aspiración - impulsión   | Extractor pipe - impulse      | 1        | 1                     | 1        |  |  |
| 11   | Q881324 | Abrazadera 50 - 70                | Clamp 50 - 70                 | 2        | 2                     | 2        |  |  |
| 12   | Z701102 | Manguito                          | Socket                        | 1        | 1                     | 1        |  |  |
| 13   | Z951101 | Tubería flexible L=1.000          | Flexible tube L=1,000         | 3        | 3                     | 3        |  |  |
| 14   | Q306038 | Arandela junta Ø31xØ21x1,5        | Joint washer Ø31xØ21x10.5     | 6        | 6                     | 6        |  |  |
| 15   | Z162306 | Manguito doble 1"                 | Double socket 1"              | 2        | 2                     | 2        |  |  |
| 16   | 3715300 | Tubo de goma Ø24xØ14x1300         | Rubber pipe Ø24xØ14x1300      | 1        | 1                     | 1        |  |  |
| 17   | 3715300 | Tubo de goma Ø24xØ14x1300         | Rubber pipe Ø24xØ14x1300      | 1        | 1                     | 1        |  |  |
| 18   | Q881336 | Abrazadera 16 - 27                | Clamp 16 - 27                 | 2        | 2                     | 2        |  |  |
| 19   | Q223023 | Tuerca hexagonal 5/8"             | Hexagonal nut 5/8"            | 1        | 1                     | 1        |  |  |
| 20   | Q307032 | Arandela junta Ø32xØ21x3          | Joint washer Ø32xØ21x3        | 1        | 1                     | 1        |  |  |
| 21   | Z281901 | Pasamuros aclarado                | Rinse wire protection         | 1        | 1                     | 1        |  |  |
| 22   | Q307063 | Junta tórica Ø19,35xØ12,29xØ3,53  | "O" ring Ø19,35xØ12,29xØ30.53 | 1        | 1                     | 1        |  |  |

# Зип Общепит

vsezip.ru

ZONA

+7(812)987-08-81

| MOD. |         | LAVAVAJILLAS DE CINTA              |                                 | PARTE FUNCIONAL ACLAR |          |          |
|------|---------|------------------------------------|---------------------------------|-----------------------|----------|----------|
| ITEM | CODIGO  | DENOMINACION                       | TEXTO                           | ECO-2700              | ECO-4000 | ECO-6000 |
| 23   | Q223108 | Tuerca M-24x2,5                    | Nut M-24x20.5                   | 1                     | 1        | 1        |
| 24   | Q221324 | Tuerca hexagonal 3/4" gas          | Hexagonal nut 3/4" gas          | 1                     | 1        | 1        |
| 25   | Z701135 | Electrovalvula entrada agua simple | Simple water inlet electrovalve | 1                     | 1        | 1        |
| 26   | Q881302 | Abrazadera 12 - 20                 | Clamp 12 - 20                   | 2                     | 2        | 2        |
| 27   | 3676900 | Tubo de goma Ø17xØ10x1.700         | Rubber pipe Ø17xØ10x1.700       | 1                     | 1        | 1        |
| 28   | Q223023 | Tuerca hexagonal 5/8"              | Hexagonal nut 5/8"              | 1                     | 1        | 1        |
| 29   | Q307032 | Arandela junta Ø32xØ21x3           | Joint washer Ø32xØ21x3          | 1                     | 1        | 1        |
| 30   | Z821910 | Pasamuros conducto llenado         | Filling pipe wire protection    | 1                     | 1        | 1        |
| 31   | Q223106 | Tuerca unión conducto              | Pipe nut joint                  | 1                     | 1        | 1        |
| 32   | Z331101 | Conducto de llenado                | Filling pipe                    | 1                     | 1        | 1        |
| 33   | Z511905 | Amarre superior aclarado "A"       | Upper anchoring rinse "A"       | 1                     | 1        | 1        |
|      | Q302022 | Arandela plana Ø16xØ6x1,2          | Flat washer Ø16xØ6x10.2         | 2                     | 2        | 2        |
|      | Q262040 | Arandela muelle A-6                | Spring washer A-6               | 2                     | 2        | 2        |
|      | Q162040 | Tuerca hexagonal M-6               | Hexagonal nut M-6               | 2                     | 2        | 2        |
| 34   | Z511901 | Árbol aclarado completo            | Complete rinse arbour           | 1                     | 1        | 1        |
|      | Q232040 | Arandela plana A-6                 | Flat washer A-6                 | 2                     | 2        | 2        |
|      | Q262030 | Arandela muelle A-5                | Spring washer A-5               | 2                     | 2        | 2        |
|      | Q212031 | Tuerca sombrerete M-5              | Cowl nut M-5                    | 2                     | 2        | 2        |
| 35   | Z511906 | Amarre superior aclarado "B"       | Upper anchoring rinse "B"       | 1                     | 1        | 1        |
|      | Q302022 | Arandela plana Ø16xØ6x1,2          | Flat washer Ø16xØ6x10.2         | 2                     | 2        | 2        |
|      | Q262040 | Arandela muelle A-6                | Spring washer A-6               | 2                     | 2        | 2        |
|      | Q162040 | Tuerca hexagonal M-6               | Hexagonal nut M-6               | 2                     | 2        | 2        |
| 36   | Z211903 | Tobera de aclarado                 | Rinse nozzle                    | 10                    | 10       | 10       |
| 37   | Z511907 | Sujeción rama inferior aclarado    | Rinse lower branch fastening    | 1                     | 1        | 1        |
|      | Q232040 | Arandela plana A-6                 | Flat washer A-6                 | 1                     | 1        | 1        |
|      | Q262040 | Arandela muelle A-6                | Spring washer A-6               | 1                     | 1        | 1        |
|      | Q212040 | Tuerca sombrerete M-6              | Cowl nut M-6                    | 1                     | 1        | 1        |
| 38   | Z311101 | Te-soporte completo                | Complete T support              | 1                     | 1        | 1        |
|      | Q012042 | Tornillo hexagonal M-6x15          | Hexagonal screw M-6x15          | 2                     | 2        | 2        |

# Зип Общепит

vsezip.ru

+7(812)987-08-81

| MOD. |         | LAVAVAJILLAS DE CINTA     | ZONA                    | PARTE FUNCIONAL ACLAR |          |          |  |
|------|---------|---------------------------|-------------------------|-----------------------|----------|----------|--|
| ITEM | CODIGO  | DENOMINACION              | TEXTO                   | ECO-2700              | ECO-4000 | ECO-6000 |  |
|      | Q302022 | Arandela plana Ø16xØ6x1,2 | Flat washer Ø16xØ6x10.2 | 2                     | 2        | 2        |  |
|      | Q262040 | Arandela muelle A-6       | Spring washer A-6       | 2                     | 2        | 2        |  |
|      | Q162040 | Tuerca hexagonal M-6      | Hexagonal nut M-6       | 2                     | 2        | 2        |  |
| 39   | Z316419 | Empalme 3/4"              | Joint 3/4"              | 2                     | 2        | 2        |  |
| 40   | Q881336 | Abrazadera 27 - 16        | Clamp 27 - 16           | 2                     | 2        | 2        |  |
|      |         |                           |                         |                       |          |          |  |
|      |         |                           |                         |                       |          |          |  |
|      |         |                           |                         |                       |          |          |  |
|      |         |                           |                         |                       |          |          |  |
|      |         |                           |                         |                       |          |          |  |
|      |         |                           |                         |                       |          |          |  |
|      |         |                           |                         |                       |          |          |  |
|      |         |                           |                         |                       |          |          |  |
|      |         |                           |                         |                       |          |          |  |
|      |         |                           |                         |                       |          |          |  |
|      |         |                           |                         |                       |          |          |  |
|      |         |                           |                         |                       |          |          |  |
|      |         |                           |                         |                       |          |          |  |
|      |         |                           |                         |                       |          |          |  |
|      |         |                           |                         |                       |          |          |  |
|      |         |                           |                         |                       |          |          |  |
|      |         |                           |                         |                       |          |          |  |
|      |         |                           |                         |                       |          |          |  |
|      |         |                           |                         |                       |          |          |  |
|      |         |                           |                         |                       |          |          |  |
|      |         |                           |                         |                       |          |          |  |
|      |         |                           |                         |                       |          |          |  |
|      |         |                           |                         |                       |          |          |  |



Зип Общепит

vsezip.ru

+7(812)987-08-81

N plano  
C-1555

Firma  

Fecha  
7-2004

Aparato  
LAVAVAJILLAS DE CINTA  
SISTEMA DE ARRASTRE

Lamina  
11

Fagor Industrial S. Coop.  
Onate

**FAGOR** 

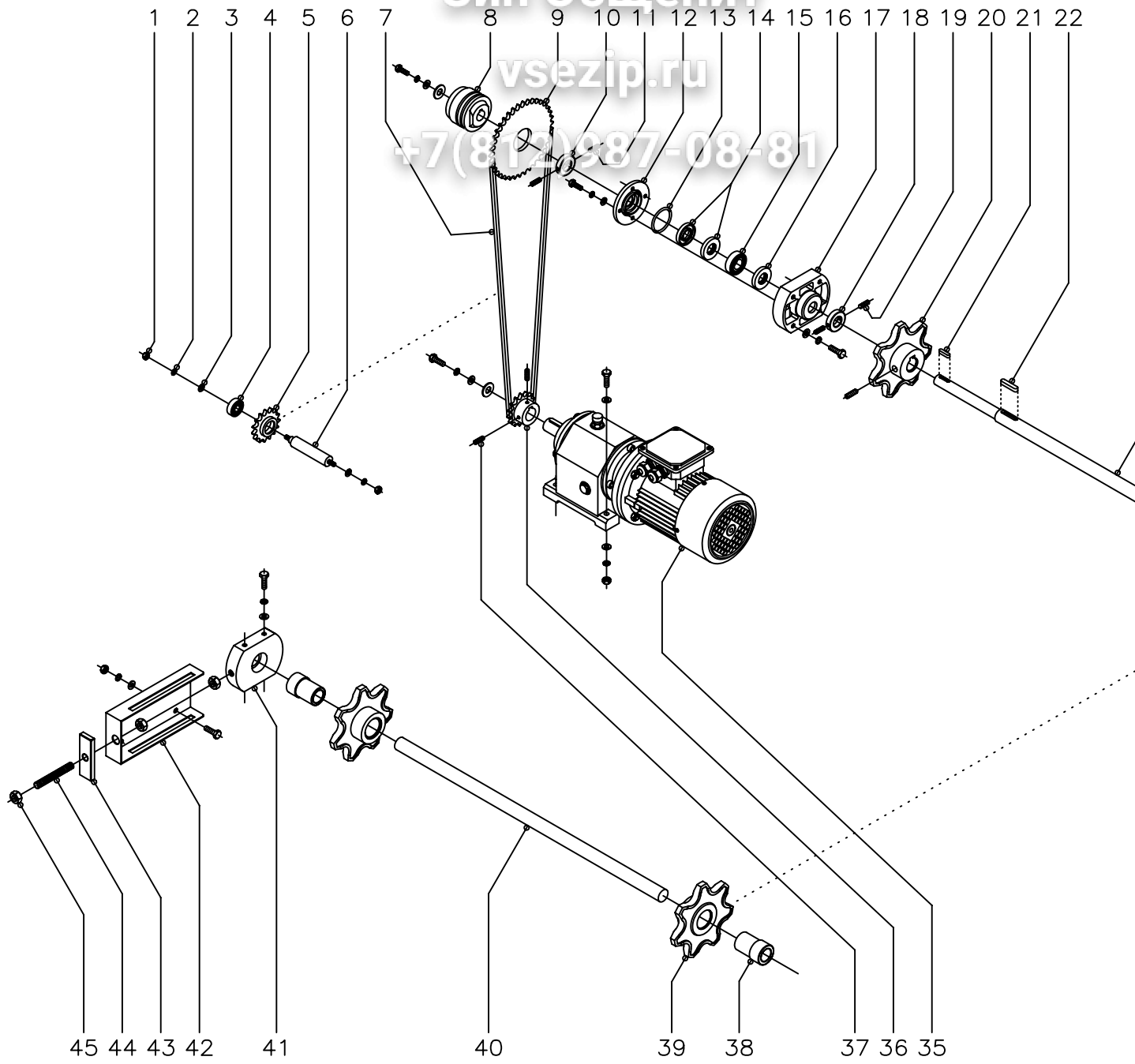

# Зип Общепит

vsezip.ru

ZONA

SISTEMA DE ARRAS

MOD.

LAVAVAJILLAS DE CINTA

+7(812)987-08-81

| ITEM | CODIGO  | DENOMINACION                      | TEXTO                            | 2700 | 4000 | 6000 |  |
|------|---------|-----------------------------------|----------------------------------|------|------|------|--|
| 1    | Q222012 | Tuerca hexagonal autoblocante M-6 | Autolocking hexagonal nut M-6    | 1    | 1    | 1    |  |
| 2    | Q262040 | Arandela muelle A-6               | Spring washer A-6                | 1    | 1    | 1    |  |
| 3    | Q302022 | Arandela plana Ø16xØ6x1,2         | Flat washer Ø16xØ6x10.2          | 1    | 1    | 1    |  |
| 4    | Z515007 | Rodamiento 6201 - 2Z              | Bearing 6201 - 2Z                | 1    | 1    | 1    |  |
| 5    | Z515006 | Piñón tensor cadena ( Z=13 )      | Chain turnbuckle pinion ( Z=13 ) | 1    | 1    | 1    |  |
| 6    | Z515005 | Eje piñón tensor                  | Turnbuckle pinion spindle        | 1    | 1    | 1    |  |
|      | Q232050 | Arandela plana A-8                | Flat washer A-8                  | 1    | 1    | 1    |  |
|      | Q262050 | Arandela muelle A-8               | Spring washer A-8                | 1    | 1    | 1    |  |
|      | Q162050 | Tuerca hexagonal M-8x1            | Hexagonal nut M-8x1              | 1    | 1    | 1    |  |
| 7    | Z275008 | Cadena Iris 12,7x7,95x730         | Iris chain 12.7x7,95x730         | 1    | 1    | 1    |  |
|      | Z105012 | Enganche extremos cadena          | Chain end hook                   | 1    | 1    | 1    |  |
| 8    | Z105008 | Limitador de par LS-70            | Torque limiter LS-70             | 1    | 1    | 1    |  |
|      | Q012042 | Tornillo hexagonal M-6x15         | Hexagonal screw M-6x15           | 1    | 1    | 1    |  |
|      | Q262040 | Arandela muelle A-6               | Spring washer A-6                | 1    | 1    | 1    |  |
|      | Q232040 | Arandela plana A-6                | Flat washer A-6                  | 1    | 1    | 1    |  |
|      | Q301010 | Arandela plana Ø27xØ12,5x2,5      | Flat washer Ø27xØ12,5x20.5       | 1    | 1    | 1    |  |
| 9    | Z515008 | Corona 2700 ( Z=50 )              | Annulus 2700 ( Z=50 )            | 1    | -    | -    |  |
| 9    | Z535008 | Corona 4000 ( Z=36 )              | Annulus 4000 ( Z=36 )            | -    | 1    | -    |  |
| 9    | Z555008 | Corona 6000 ( Z=25 )              | Annulus 6000 ( Z=25 )            | -    | -    | 1    |  |
| 10   | Z515024 | Tope rueda motriz                 | Driver buffer                    | 1    | 1    | 1    |  |
| 11   | Q132002 | Varilla roscada M-5x16            | Threaded rod M-5x16              | 2    | 2    | 2    |  |
| 12   | Z515016 | Cubierta posterior rodamientos    | Bearings rear cover              | 1    | 1    | 1    |  |
|      | Q012042 | Tornillo hexagonal M-6x15         | Hexagonal screw M-6x15           | 4    | 4    | 4    |  |
|      | Q262040 | Arandela muelle A-6               | Spring washer A-6                | 4    | 4    | 4    |  |
|      | Q232040 | Arandela plana A-6                | Flat washer A-6                  | 4    | 4    | 4    |  |
| 13   | Q307071 | Junta tórica Ø51,1xØ44,04xØ3,53   | "O" ring Ø51,1xØ44,04xØ30.53     | 1    | 1    | 1    |  |
| 14   | Z515015 | Reten Ø42xØ20x7                   | Retainer Ø42xØ20x7               | 2    | 2    | 2    |  |
| 15   | Z515014 | Rodamiento 6004 - 2RS             | Bearing 6004 - 2RS               | 1    | 1    | 1    |  |
| 16   | Z515015 | Reten Ø42xØ20x7                   | Retainer Ø42xØ20x7               | 1    | 1    | 1    |  |

# Зип Общепит

vsezip.ru

ZONA

+7(812)987-08-81

| MOD. |         | LAVAVAJILLAS DE CINTA           | ZONA                        |      | SISTEMA DE ARRAS |      |  |
|------|---------|---------------------------------|-----------------------------|------|------------------|------|--|
| ITEM | CODIGO  | DENOMINACION                    | TEXTO                       | 2700 | 4000             | 6000 |  |
| 17   | Z515013 | Soporte rodamiento              | Bearing support             | 1    | 1                | 1    |  |
|      | Q012053 | Tornillo hexagonal M-8x20       | Hexagonal screw M-8x20      | 4    | 4                | 4    |  |
|      | Q262050 | Arandela muelle A-8             | Spring washer A-8           | 4    | 4                | 4    |  |
|      | Q232050 | Arandela plana A-8              | Flat washer A-8             | 4    | 4                | 4    |  |
| 18   | Z515024 | Tope rueda motriz               | Driver buffer               | 1    | 1                | 1    |  |
| 19   | Q132002 | Varilla roscada M-5x16          | Threaded rod M-5x16         | 2    | 2                | 2    |  |
| 20   | Z515021 | Rueda motriz completa           | Complete driver             | 1    | 1                | 1    |  |
|      | Q132001 | Varilla roscada M-8x16          | Threaded rod M-8x16         | 1    | 1                | 1    |  |
| 21   | Z105014 | Chaveta 25x6x6                  | Key 25x6x6                  | 1    | 1                | 1    |  |
| 22   | Z515012 | Chaveta 40x8x7                  | Key 40x8x7                  | 1    | 1                | 1    |  |
| 23   | Z515011 | Eje motriz                      | Driving pin                 | 1    | 1                | 1    |  |
| 24   | Z515012 | Chaveta 40x8x7                  | Key 40x8x7                  | 1    | 1                | 1    |  |
| 25   | Z515021 | Rueda motriz completa           | Complete driver             | 1    | 1                | 1    |  |
| 26   | Q132001 | Varilla roscada M-8x16          | Threaded rod M-8x16         | 1    | 1                | 1    |  |
| 27   | Z515024 | Tope rueda motriz               | Driver buffer               | 1    | 1                | 1    |  |
| 28   | Q132002 | Varilla roscada M-5x16          | Threaded rod M-5x16         | 2    | 2                | 2    |  |
| 29   | Z515013 | Soporte rodamiento              | Bearing support             | 1    | 1                | 1    |  |
|      | Q012053 | Tornillo hexagonal M-8x20       | Hexagonal screw M-8x20      | 4    | 4                | 4    |  |
|      | Q262050 | Arandela muelle A-8             | Spring washer A-8           | 4    | 4                | 4    |  |
|      | Q232050 | Arandela plana A-8              | Flat washer A-8             | 4    | 4                | 4    |  |
| 30   | Z515015 | Reten Ø42xØ20x7                 | Retainer Ø42xØ20x7          | 1    | 1                | 1    |  |
| 31   | Z515014 | Rodamiento 6004 - 2RS           | Bearing 6004 - 2RS          | 1    | 1                | 1    |  |
| 32   | Z515015 | Reten Ø42xØ20x7                 | Retainer Ø42xØ20x7          | 2    | 2                | 2    |  |
| 33   | Q307071 | Junta tórica Ø51,1xØ44,04xØ3,53 | "O" ring Ø51,1xØ44,04xØ3,53 | 1    | 1                | 1    |  |
| 34   | Z515018 | Cubierta anterior rodamientos   | Bearings front cover        | 1    | 1                | 1    |  |
|      | Q012042 | Tornillo hexagonal M-6x15       | Hexagonal screw M-6x15      | 4    | 4                | 4    |  |
|      | Q262040 | Arandela muelle A-6             | Spring washer A-6           | 4    | 4                | 4    |  |
|      | Q232040 | Arandela plana A-6              | Flat washer A-6             | 4    | 4                | 4    |  |
| 35   | Z515001 | Motorreductor                   | Geared motor                | 1    | 1                | 1    |  |

# Зип Общепит

vsezip.ru

+7(812)987-08-81

| MOD. |         | LAVAVAJILLAS DE CINTA        | ZONA                         | SISTEMA DE ARRAS |      |      |  |
|------|---------|------------------------------|------------------------------|------------------|------|------|--|
| ITEM | CODIGO  | DENOMINACION                 | TEXTO                        | 2700             | 4000 | 6000 |  |
|      | Q012055 | Tornillo hexagonal M-8x30    | Hexagonal screw M-8x30       | 4                | 4    | 4    |  |
|      | Q232050 | Arandela plana A-8           | Flat washer A-8              | 8                | 8    | 8    |  |
|      | Q262050 | Arandela muelle A-8          | Spring washer A-8            | 4                | 4    | 4    |  |
|      | Q162050 | Tuerca hexagonal M-8x1       | Hexagonal nut M-8x1          | 4                | 4    | 4    |  |
| 36   | Z515002 | Piñón motorreductor ( Z=15 ) | Geared motor pinion ( Z=15 ) | 1                | 1    | 1    |  |
|      | Q012052 | Tornillo hexagonal M-8x15    | Hexagonal screw M-8x15       | 1                | 1    | 1    |  |
|      | Q262050 | Arandela muelle A-8          | Spring washer A-8            | 1                | 1    | 1    |  |
|      | Q232050 | Arandela plana A-8           | Flat washer A-8              | 1                | 1    | 1    |  |
|      | Q301010 | Arandela plana Ø27xØ12,5x2,5 | Flat washer Ø27xØ12,5x20.5   | 1                | 1    | 1    |  |
| 37   | Q132041 | Varilla roscada M-6x10       | Threaded rod M-6x10          | 2                | 2    | 2    |  |
| 38   | Z515036 | Casquillo eje auxiliar       | Auxiliary spindle socket     | 2                | 2    | 2    |  |
| 39   | Z515033 | Rueda auxiliar completa      | Complete auxiliary wheel     | 2                | 2    | 2    |  |
| 40   | Z515032 | Eje auxiliar                 | Auxiliary spindle            | 1                | 1    | 1    |  |
| 41   | Z515031 | Tensor                       | Turnbuckle                   | 2                | 2    | 2    |  |
|      | Q012052 | Tornillo hexagonal M-8x15    | Hexagonal screw M-8x15       | 8                | 8    | 8    |  |
|      | Q262050 | Arandela muelle A-8          | Spring washer A-8            | 8                | 8    | 8    |  |
|      | Q232050 | Arandela plana A-8           | Flat washer A-8              | 8                | 8    | 8    |  |
| 42   | Z510438 | Soporte tensor               | Turnbuckle support           | 2                | 2    | 2    |  |
|      | Q012052 | Tornillo hexagonal M-8x15    | Hexagonal screw M-8x15       | 8                | 8    | 8    |  |
|      | Q232050 | Arandela plana A-8           | Flat washer A-8              | 8                | 8    | 8    |  |
|      | Q262050 | Arandela muelle A-8          | Spring washer A-8            | 8                | 8    | 8    |  |
|      | Q162050 | Tuerca hexagonal M-8x1       | Hexagonal nut M-8x1          | 8                | 8    | 8    |  |
| 43   | Z510439 | Calzo tensor                 | Turnbuckle wedge             | 2                | 2    | 2    |  |
| 44   | Z510437 | Espárrago roscado M-12x90    | Threaded stud-bolt M-12x90   | 2                | 2    | 2    |  |
| 45   | Q162070 | Tuerca hexagonal M-12        | Hexagonal nut M-12           | 6                | 6    | 6    |  |
|      |         |                              |                              |                  |      |      |  |
|      |         |                              |                              |                  |      |      |  |
|      |         |                              |                              |                  |      |      |  |

Зип Общежит

vsezip.ru

+7(812)987-08-81

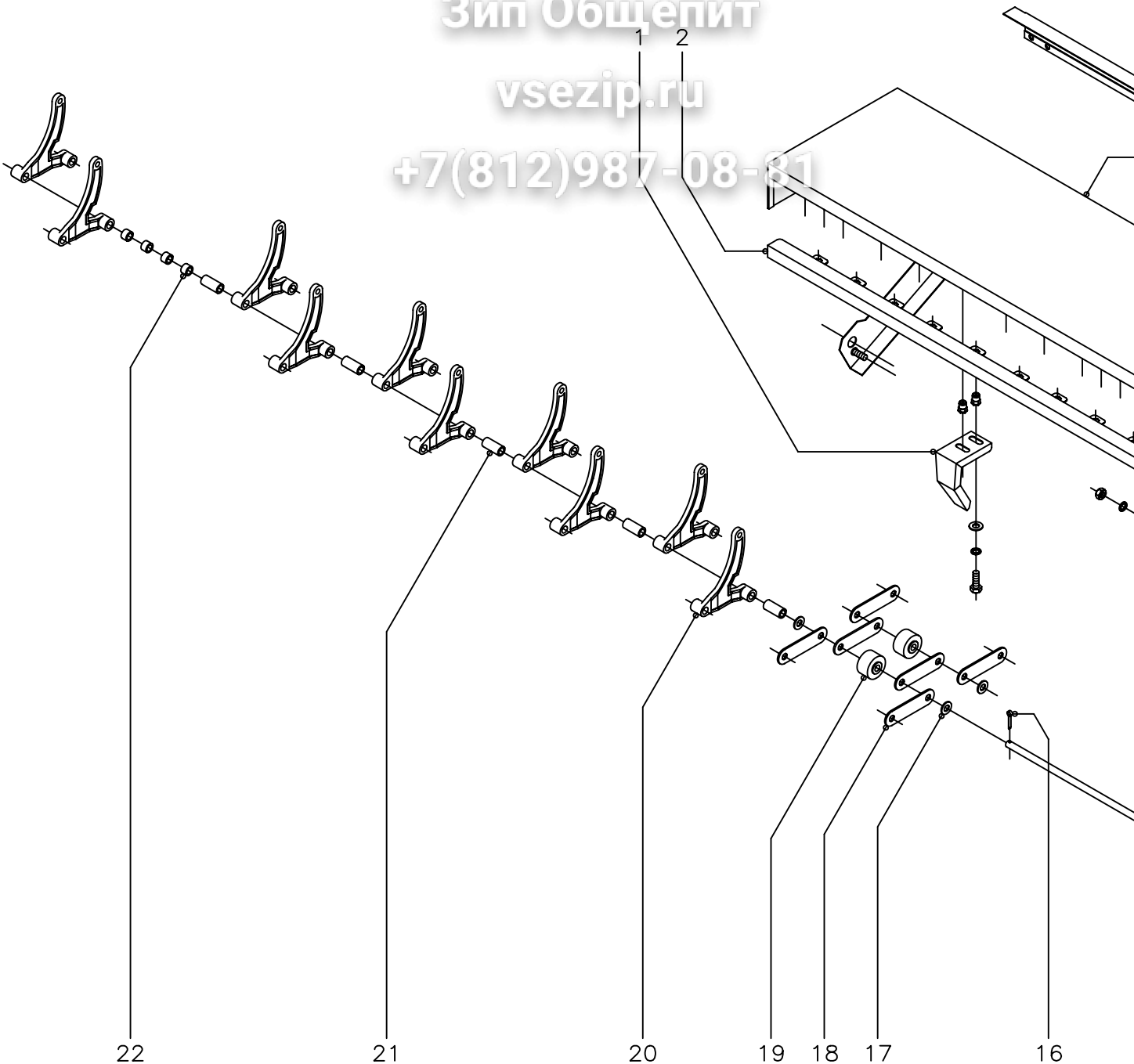

N plano  
C-1556

Firma

Fecha  
7-2004

Aparato  
LAVAVAJILLAS DE CINTA  
CINTA Y TOPE PLATOS

Lamina  
12

Fagor Industrial S. Coop. **FAGOR**  
Orate

# Зип Общепит

vsezip.ru

ZONA

CINTA Y TOPE PLAT

MOD.

LAVAVAJILLAS DE CINTA

+7(812)987-08-81

| ITEM | CODIGO  | DENOMINACION                         | TEXTO                           | 2700 | 4000 | 6000 |  |
|------|---------|--------------------------------------|---------------------------------|------|------|------|--|
| 1    | Z512946 | Suplemento tope platos               | Plate buffer supplement         | 9    | 9    | 9    |  |
|      | Q012031 | Tornillo hexagonal M-5x10            | Hexagonal screw M-5x10          | 18   | 18   | 18   |  |
|      | Q262030 | Arandela muelle A-5                  | Spring washer A-5               | 18   | 18   | 18   |  |
|      | Q302022 | Arandela plana Ø16xØ6x1,2            | Flat washer Ø16xØ6x10.2         | 18   | 18   | 18   |  |
| 2    | Z512945 | Soporte suplemento tope platos       | Extra plate buffer support      | 1    | 1    | 1    |  |
|      | Q221342 | Remache hexagonal M-5                | Hexagonal rivet M-5             | 18   | 18   | 18   |  |
| 3    | Z512944 | Amarre resorte                       | Spring anchoring                | 1    | 1    | 1    |  |
| 4    | Z512937 | Tope platos completo                 | Complete plate buffer           | 1    | 1    | 1    |  |
| 5    | Z512955 | Resorte tope platos                  | Plate buffer spring             | 2    | 2    | 2    |  |
| 6    | Z512954 | Sujeción resorte                     | Spring support                  | 2    | 2    | 2    |  |
|      | Q262030 | Arandela muelle A-5                  | Spring washer A-5               | 2    | 2    | 2    |  |
|      | Q162030 | Tuerca hexagonal M-5                 | Hexagonal nut M-5               | 2    | 2    | 2    |  |
| 7    | Z512951 | Eje tope platos soldado              | Welded plate buffer spindle     | 2    | 2    | 2    |  |
|      | Q302022 | Arandela plana Ø16xØ6x1,2            | Flat washer Ø16xØ6x10.2         | 2    | 2    | 2    |  |
|      | Q262040 | Arandela muelle A-6                  | Spring washer A-6               | 2    | 2    | 2    |  |
|      | Q162040 | Tuerca hexagonal M-6                 | Hexagonal nut M-6               | 2    | 2    | 2    |  |
| 8    | Z511201 | Casquillo roscado 5/8"               | Threaded bush 5/8"              | 2    | 2    | 2    |  |
| 9    | Q307032 | Arandela junta Ø32xØ21x3             | Joint washer Ø32xØ21x3          | 2    | 2    | 2    |  |
| 10   | Q223023 | Tuerca hexagonal 5/8"                | Hexagonal nut 5/8"              | 2    | 2    | 2    |  |
| 11   | Z511209 | Leva                                 | Cam                             | 1    | 1    | 1    |  |
| 12   | Q371031 | Manguito sujeción Ø3x20              | Fastening socket Ø3x20          | 1    | 1    | 1    |  |
| 13   | Z513007 | Final de carrera (Micro tope platos) | End of run (Micro plate buffer) | 1    | 1    | 1    |  |
|      | Q152026 | Tornillo avellanado M-4x35           | Countersunk screw M-4x35        | 2    | 2    | 2    |  |
|      | Q242020 | Arandela abanico A-4                 | Fan shaped washer A-4           | 2    | 2    | 2    |  |
|      | Q162020 | Tuerca hexagonal M-4                 | Hexagonal nut M-4               | 2    | 2    | 2    |  |
| 14   | Z511231 | Soporte micro aclarado               | Micro rinse support             | 1    | 1    | 1    |  |
|      | Q232040 | Arandela plana A-6                   | Flat washer A-6                 | 2    | 2    | 2    |  |
|      | Q222012 | Tuerca hexagonal autoblocante M-6    | Autolocking hexagonal nut M-6   | 2    | 2    | 2    |  |
| 15   | Z515039 | Eje cinta                            | Belt spindle                    | 147  | 177  | 207  |  |

# Зип Общепит

vsezip.ru

+7(812)987-08-81

| MOD. |         | LAVAVAJILLAS DE CINTA   | ZONA                      | CINTA Y TOPE PLAT |      |      |  |
|------|---------|-------------------------|---------------------------|-------------------|------|------|--|
| ITEM | CODIGO  | DENOMINACION            | TEXTO                     | 2700              | 4000 | 6000 |  |
| 16   | Q352001 | Pasador de aletas Ø2x15 | Cotter pin Ø2x15          | 294               | 354  | 414  |  |
| 17   | Q232050 | Arandela plana A-8      | Flat washer A-8           | 588               | 708  | 828  |  |
| 18   | Z515040 | Distanciador            | Spacer                    | 588               | 708  | 828  |  |
| 19   | Z775004 | Rueda                   | Wheel                     | 294               | 354  | 414  |  |
| 20   | Z515041 | Pico arrastre platos    | Plate transport front end | 1176              | 1416 | 1656 |  |
| 21   | Z515044 | Casquillo separador "A" | Separating socket "A"     | 1323              | 1593 | 1863 |  |
| 22   | Z515045 | Casquillo separador "B" | Separating socket "B"     | 588               | 708  | 828  |  |
|      |         |                         |                           |                   |      |      |  |
|      |         |                         |                           |                   |      |      |  |
|      |         |                         |                           |                   |      |      |  |
|      |         |                         |                           |                   |      |      |  |
|      |         |                         |                           |                   |      |      |  |
|      |         |                         |                           |                   |      |      |  |
|      |         |                         |                           |                   |      |      |  |
|      |         |                         |                           |                   |      |      |  |
|      |         |                         |                           |                   |      |      |  |
|      |         |                         |                           |                   |      |      |  |
|      |         |                         |                           |                   |      |      |  |
|      |         |                         |                           |                   |      |      |  |
|      |         |                         |                           |                   |      |      |  |
|      |         |                         |                           |                   |      |      |  |
|      |         |                         |                           |                   |      |      |  |
|      |         |                         |                           |                   |      |      |  |
|      |         |                         |                           |                   |      |      |  |
|      |         |                         |                           |                   |      |      |  |
|      |         |                         |                           |                   |      |      |  |
|      |         |                         |                           |                   |      |      |  |
|      |         |                         |                           |                   |      |      |  |
|      |         |                         |                           |                   |      |      |  |
|      |         |                         |                           |                   |      |      |  |
|      |         |                         |                           |                   |      |      |  |
|      |         |                         |                           |                   |      |      |  |

Zip Общепит

vsezip.ru

+7(812)987-08-81

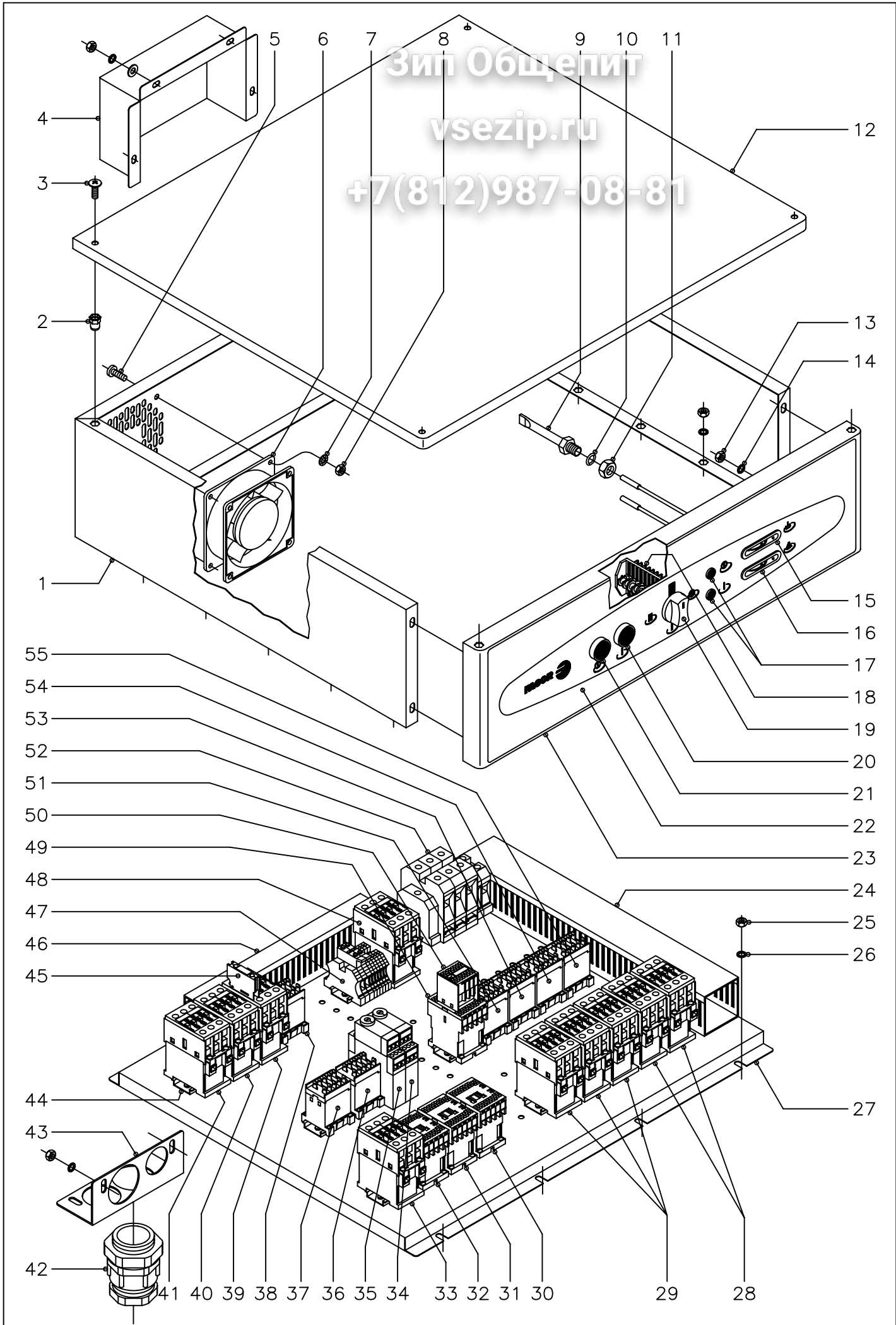

|                   |           |                 |   |              |  |
|-------------------|-----------|-----------------|---|--------------|--|
| N plano<br>C-1557 | Firma<br> | Fecha<br>7-2004 | Aparato<br>LAVAVAJILLAS DE CINTA<br>PARTE ELECTRICA | Lamina<br>13 | Fagor Industrial S.Coop. <b>FAGOR</b><br>Onate |
|-------------------|-----------|-----------------|---|--------------|--|



# Зип Общепит

vsezip.ru

ZONA

PARTE ELECT

+7(812)987-08-81

| MOD. |         | LAVAVAJILLAS DE CINTA               |                                       | PARTE ELECT |         |         |          |
|------|---------|-------------------------------------|---------------------------------------|-------------|---------|---------|----------|
| ITEM | CODIGO  | DENOMINACION                        | TEXTO                                 | FI-2700     | FI-4000 | FI-6000 | ECO-2700 |
| 1    | Z513012 | Cubierta cuadro eléctrico completo  | Complete switchboard cover            | 1           | 1       | 1       | 1        |
|      | Q262040 | Arandela muelle A-6                 | Spring washer A-6                     | 12          | 12      | 12      | 12       |
|      | Q162040 | Tuerca hexagonal M-6                | Hexagonal nut M-6                     | 12          | 12      | 12      | 12       |
| 2    | Q221343 | Remache hexagonal M-6               | Hexagonal rivet M-6                   | 4           | 4       | 4       | 4        |
| 3    | Q152017 | Tornillo amarre M-6x13              | Anchoring screw M-6x13                | 4           | 4       | 4       | 4        |
| 4    | Z513017 | Posterior cuadro eléctrico          | Switchboard rear                      | 1           | 1       | 1       | 1        |
|      | Q302022 | Arandela plana Ø16xØ6x1,2           | Flat washer Ø16xØ6x10.2               | 4           | 4       | 4       | 4        |
|      | Q262040 | Arandela muelle A-6                 | Spring washer A-6                     | 4           | 4       | 4       | 4        |
|      | Q162040 | Tuerca hexagonal M-6                | Hexagonal nut M-6                     | 4           | 4       | 4       | 4        |
| 5    | Q031322 | Tornillo alomado M-4x15             | Curved screw M-4x15                   | 4           | 4       | 4       | 4        |
| 6    | Z103066 | Ventilador 230 V., 50/60 Hz.        | Ventilator 230 V., 50/60 Hz.          | 1           | 1       | 1       | 1        |
| 7    | Q242020 | Arandela abanico A-4                | Fan shaped washer A-4                 | 4           | 4       | 4       | 4        |
| 8    | Q162020 | Tuerca hexagonal M-4                | Hexagonal nut M-4                     | 4           | 4       | 4       | 4        |
| 9    | Z263002 | Vaina para bulbo                    | Case for bulb                         | 1           | 1       | 1       | 1        |
| 10   | Q307048 | Junta tórica Ø16,18xØ9,12xØ3,53     | "O" ring Ø16,18xØ9,12xØ3.53           | 1           | 1       | 1       | 1        |
| 11   | Q162070 | Tuerca hexagonal M-12               | Hexagonal nut M-12                    | 1           | 1       | 1       | 1        |
| 12   | Z513016 | Tapa cuadro eléctrico               | Switchboard lid                       | 1           | 1       | 1       | 1        |
| 13   | Q162040 | Tuerca hexagonal M-6                | Hexagonal nut M-6                     | 4           | 4       | 4       | 4        |
| 14   | Q262040 | Arandela muelle A-6                 | Spring washer A-6                     | 4           | 4       | 4       | 4        |
| 15   | Z263001 | Indicador analógico (cuba lavado)   | Analogical indicator (wash tub)       | 1           | 1       | 1       | 1        |
| 16   | Z263001 | Indicador analógico (calderín acl.) | Analogical indicator (rinse wash tub) | 1           | 1       | 1       | -        |
| 17   | R693056 | Piloto ámbar                        | Amber pilot light                     | 2           | 2       | 2       | 2        |
| 18   | Z273005 | Conmutador de funciones             | Function switch                       | 1           | 1       | 1       | 1        |
|      | Z602906 | Casquillo distanciador              | Spacer socket                         | 2           | 2       | 2       | 2        |
|      | Q041324 | Tornillo avellanado M-4x25          | Countersunk screw M-4x25              | 2           | 2       | 2       | 2        |
| 19   | R663062 | Botón de mando completo             | Complete control button               | 1           | 1       | 1       | 1        |
| 20   | Z513003 | Pulsador verde completo             | Complete green push button            | 1           | 1       | 1       | 1        |
| 21   | Z513004 | Pulsador rojo completo              | Complete red push button              | 1           | 1       | 1       | 1        |
| 22   | Z513010 | Embellecedor adhesivo               | Adhesive trim                         | 1           | 1       | 1       | -        |

# Зип Общепит

vsezip.ru

ZONA

PARTE ELECT

+7(812)987-08-81

| MOD. |         | LAVAVAJILLAS DE CINTA                   |  | PARTE ELECT |         |         |          |
|------|---------|---|--|-------------|---------|---------|----------|
| ITEM | CODIGO  | DENOMINACION                            | TEXTO                                  | FI-2700     | FI-4000 | FI-6000 | ECO-2700 |
| 22   | Z523010 | Embellededor adhesivo                   | Adhesive trim                          | -           | -       | -       | 1        |
| 23   | Z513014 | Frente cuadro eléctrico completo        | Complete switchboard cover             | 1           | 1       | 1       | 1        |
| 24   | 3715510 | Canaleta unex 60x60x77 L=440            | Unex channel 60x60x77 G=440            | 1           | 1       | 1       | 1        |
| 24   | 3715510 | Canaleta unex 60x60x77 L=470            | Unex channel 60x60x77 G=470            | 1           | 1       | 1       | 1        |
| 24   | 3715510 | Canaleta unex 60x60x77 L=250            | Unex channel 60x60x77 G=250            | 2           | 2       | 2       | 2        |
| 25   | Q162040 | Tuerca hexagonal M-6                    | Hexagonal nut M-6                      | 8           | 8       | 8       | 8        |
| 26   | Q262040 | Arandela muelle A-6                     | Spring washer A-6                      | 8           | 8       | 8       | 8        |
| 27   | Z513011 | Soporte cuadro eléctrico                | Switchboard support                    | 1           | 1       | 1       | 1        |
| 28   | X183011 | Contactador ( resistencias tanque )     | Contactador ( tank resistors )         | 2           | 2       | 2       | -        |
| 29   | X183011 | Contactador ( resistencias calderín )   | Contactador ( wash tub resistors )     | 3           | 3       | 3       | 3        |
| 30   | Z203050 | Contactador ( extractor o condensador ) | Contactador ( extractor or condenser ) | 1           | 1       | 1       | 1        |
| 31   | Z203050 | Contactador ( secado )                  | Contactador ( dryer )                  | 1           | 1       | 1       | 1        |
| 32   | Z203050 | Contactador ( recuperador energía )     | Contactador ( energy recovery )        | 1           | 1       | 1       | 1        |
| 33   | X183011 | Contactador ( resistencias calderín )   | Contactador ( wash tub resistors )     | 1           | 1       | 1       | -        |
| 34   | Z123022 | Temporizador ( aclarado )               | Timer ( rinse )                        | 1           | 1       | 1       | 1        |
| 35   | Z123022 | Temporizador ( secado )                 | Timer ( dryer )                        | 1           | 1       | 1       | 1        |
| 36   | Z213007 | Contactador ( bomba lavado 2 )          | Contactador ( pump wash 2 )            | -           | 1       | 1       | -        |
| 37   | Z213007 | Contactador ( bomba lavado 3 )          | Contactador ( pump wash 3 )            | -           | -       | 1       | -        |
| 38   | Z213007 | Contactador ( puertas )                 | Contactador ( doors )                  | 1           | 1       | 1       | 1        |
| 39   | X183011 | Contactador ( resistencias secado )     | Contactador ( drying resistors )       | 1           | 1       | 1       | 1        |
| 40   | X183011 | Contactador ( resistencias tanque 2 )   | Contactador ( tank resistors 2 )       | -           | -       | 1       | -        |
| 41   | X183011 | Contactador ( resistencias calderín )   | Contactador ( wash tub resistors )     | 1           | 1       | 1       | -        |
| 42   | Z312941 | Prensaestopas PG-42                     | Stuffing box PG-42                     | 1           | 1       | 1       | -        |
| 42   | R143010 | Prensaestopas PG-36                     | Stuffing box PG-36                     | -           | -       | -       | 1        |
| 43   | Z312966 | Soporte prensaestopas                   | Stuffing box support                   | 1           | 1       | 1       | 1        |
|      | Q262040 | Arandela muelle A-6                     | Spring washer A-6                      | 2           | 2       | 2       | 2        |
|      | Q162040 | Tuerca hexagonal M-6                    | Hexagonal nut M-6                      | 2           | 2       | 2       | 2        |
| 44   | R693009 | Guía contactor L=250                    | Contactador guide G=250                | 2           | 2       | 2       | 2        |
| 44   | R663055 | Guía contactor L=120                    | Contactador guide G=120                | 5           | 5       | 5       | 5        |

# Зип Общепит

vsezip.ru

ZONA

+7(812)987-08-81

| MOD. |         | LAVAVAJILLAS DE CINTA                 |  | ZONA    |         | PARTE ELECT |  |  |  |
|------|---------|---------------------------------------|--|---------|---------|-------------|--|--|--|
| ITEM | CODIGO  | DENOMINACION                          | TEXTO                                      | FI-2700 | FI-4000 | FI-6000     |  |  |  |
| 45   | Z103070 | Contacto auxiliar ( secado )          | Auxiliary contact ( dryer )                | 1       | 1       | 1           |  |  |  |
| 46   | 3715520 | Canaleta unex 60x30x77 L=420          | Unex channel 60x30x77 G=420                | 1       | 1       | 1           |  |  |  |
| 46   | 3715520 | Canaleta unex 60x30x77 L=610          | Unex channel 60x30x77 G=610                | 1       | 1       | 1           |  |  |  |
| 46   | 3715520 | Canaleta unex 60x30x77 L=230          | Unex channel 60x30x77 G=230                | 2       | 2       | 2           |  |  |  |
| 47   | R073005 | Bornes portafusibles                  | Fuse carrier terminals                     | 2       | 2       | 2           |  |  |  |
|      | R723015 | Cartucho fusible 10A.                 | Fuse cartridge 10 a.                       | 2       | 2       | 2           |  |  |  |
|      | Z103029 | Bornes ( detergente y tensoactivo )   | Terminals ( detergent and surface-active ) | 4       | 4       | 4           |  |  |  |
|      | Z263303 | Tope final                            | End buffer                                 | 1       | 1       | 1           |  |  |  |
| 48   | X183011 | Contactador ( calentam. preaclorado ) | Contactador ( prerinse heating )           | 1       | 1       | 1           |  |  |  |
| 49   | Z743009 | Contactador ( RA )                    | Contactador ( RA )                         | 1       | 1       | 1           |  |  |  |
| 50   | Z953046 | Contacto auxiliar ( RA )              | Auxiliary contact ( RA )                   | 1       | 1       | 1           |  |  |  |
| 51   | Z213007 | Contactador bomba lavado 1            | Contactador wash pump 1                    | 1       | 1       | 1           |  |  |  |
| 52   | R143011 | Borne fases 70 gris                   | Grey phase 70 terminal                     | 3       | 3       | 3           |  |  |  |
|      | R263003 | Borne fases 35 gris                   | Grey phase 35 terminal                     | -       | -       | -           |  |  |  |
|      | R673010 | Borne neutro 35 azul                  | Blue neutral 35 terminal                   | 1       | 1       | 1           |  |  |  |
|      | Z103035 | Borne tierra 35 verde - amarillo      | Yellow earth 35 terminal                   | 1       | 1       | 1           |  |  |  |
|      | Z683096 | Tope final                            | End buffer                                 | 1       | 1       | 1           |  |  |  |
| 53   | Z683087 | Contactador ( auxiliar aclarado )     | Contactador ( auxiliary rinse )            | 1       | 1       | 1           |  |  |  |
| 54   | Z213007 | Contactador ( avance 1 )              | Contactador ( advance 1 )                  | 1       | 1       | 1           |  |  |  |
| 55   | Z213007 | Contactador ( avance 2 )              | Contactador ( advance 2 )                  | 1       | 1       | 1           |  |  |  |
|      |         |                                       |  |         |         |             |  |  |  |
|      |         |                                       |  |         |         |             |  |  |  |
|      |         |                                       |  |         |         |             |  |  |  |
|      |         |                                       |  |         |         |             |  |  |  |
|      |         |                                       |  |         |         |             |  |  |  |
|      |         |                                       |  |         |         |             |  |  |  |
|      |         |                                       |  |         |         |             |  |  |  |
|      |         |                                       |  |         |         |             |  |  |  |
|      |         |                                       |  |         |         |             |  |  |  |
|      |         |                                       |  |         |         |             |  |  |  |

# Зип Общепит

vsezip.ru

ZONA

+7(812)987-08-81

| MOD. |         | LAVAVAJILLAS DE CINTA        | ZONA                             |  | VARIOS PARTE ELECT |         |         |          |
|------|---------|------------------------------|----------------------------------|--|--------------------|---------|---------|----------|
| ITEM | CODIGO  | DENOMINACION                 | TEXTO                            |  | FI-2700            | FI-4000 | FI-6000 | ECO-2700 |
|      | Z513031 | Instalación eléctrica base   | Base electrical installation     |  | 1                  | 1       | 1       | 1        |
|      | Z533032 | Cableado FI-4000             | Wiring FI-4000                   |  | -                  | 1       | 1       | -        |
|      | Z553032 | Cableado FI-6000             | Wiring FI-6000                   |  | -                  | -       | 1       | -        |
|      | Z283022 | Cable tierra motobomba       | Motor pump earth wire            |  | 1                  | 1       | 1       | 2        |
|      | Z513032 | Cableado fuerza base         | Base force wiring                |  | 1                  | 1       | 1       | 1        |
|      | Z513033 | Cableado calderín            | Wash tub wiring                  |  | 1                  | 1       | 1       | -        |
|      | Z323001 | Cableado ECO-280             | Wiring ECO-280                   |  | -                  | -       | -       | 1        |
|      | Z513035 | Esquema eléctrico de montaje | Electrical mounting diagramme    |  | 1                  | 1       | 1       | 1        |
|      | Z513041 | Esquema eléctrico teórico    | Theoretical electrical diagramme |  | 1                  | -       | -       | -        |
|      | Z533041 | Esquema eléctrico teórico    | Theoretical electrical diagramme |  | -                  | 1       | -       | -        |
|      | Z553041 | Esquema eléctrico teórico    | Theoretical electrical diagramme |  | -                  | -       | 1       | -        |
|      | Z523041 | Esquema eléctrico teórico    | Theoretical electrical diagramme |  | -                  | -       | -       | 1        |
|      | Z543041 | Esquema eléctrico teórico    | Theoretical electrical diagramme |  | -                  | -       | -       | -        |
|      | Z563041 | Esquema eléctrico teórico    | Theoretical electrical diagramme |  | -                  | -       | -       | -        |
|      | Z313070 | Leyenda esquema teórico      | Theoretical diagramme lettering  |  | 1                  | 1       | 1       | 1        |
|      |         |                              |                                  |  |                    |         |         |          |
|      |         |                              |                                  |  |                    |         |         |          |
|      |         |                              |                                  |  |                    |         |         |          |
|      |         |                              |                                  |  |                    |         |         |          |
|      |         |                              |                                  |  |                    |         |         |          |
|      |         |                              |                                  |  |                    |         |         |          |
|      |         |                              |                                  |  |                    |         |         |          |
|      |         |                              |                                  |  |                    |         |         |          |
|      |         |                              |                                  |  |                    |         |         |          |
|      |         |                              |                                  |  |                    |         |         |          |
|      |         |                              |                                  |  |                    |         |         |          |
|      |         |                              |                                  |  |                    |         |         |          |
|      |         |                              |                                  |  |                    |         |         |          |
|      |         |                              |                                  |  |                    |         |         |          |
|      |         |                              |                                  |  |                    |         |         |          |
|      |         |                              |                                  |  |                    |         |         |          |
|      |         |                              |                                  |  |                    |         |         |          |
|      |         |                              |                                  |  |                    |         |         |          |

Зип Общепит

vsezip.ru

+7(812)987-08-81

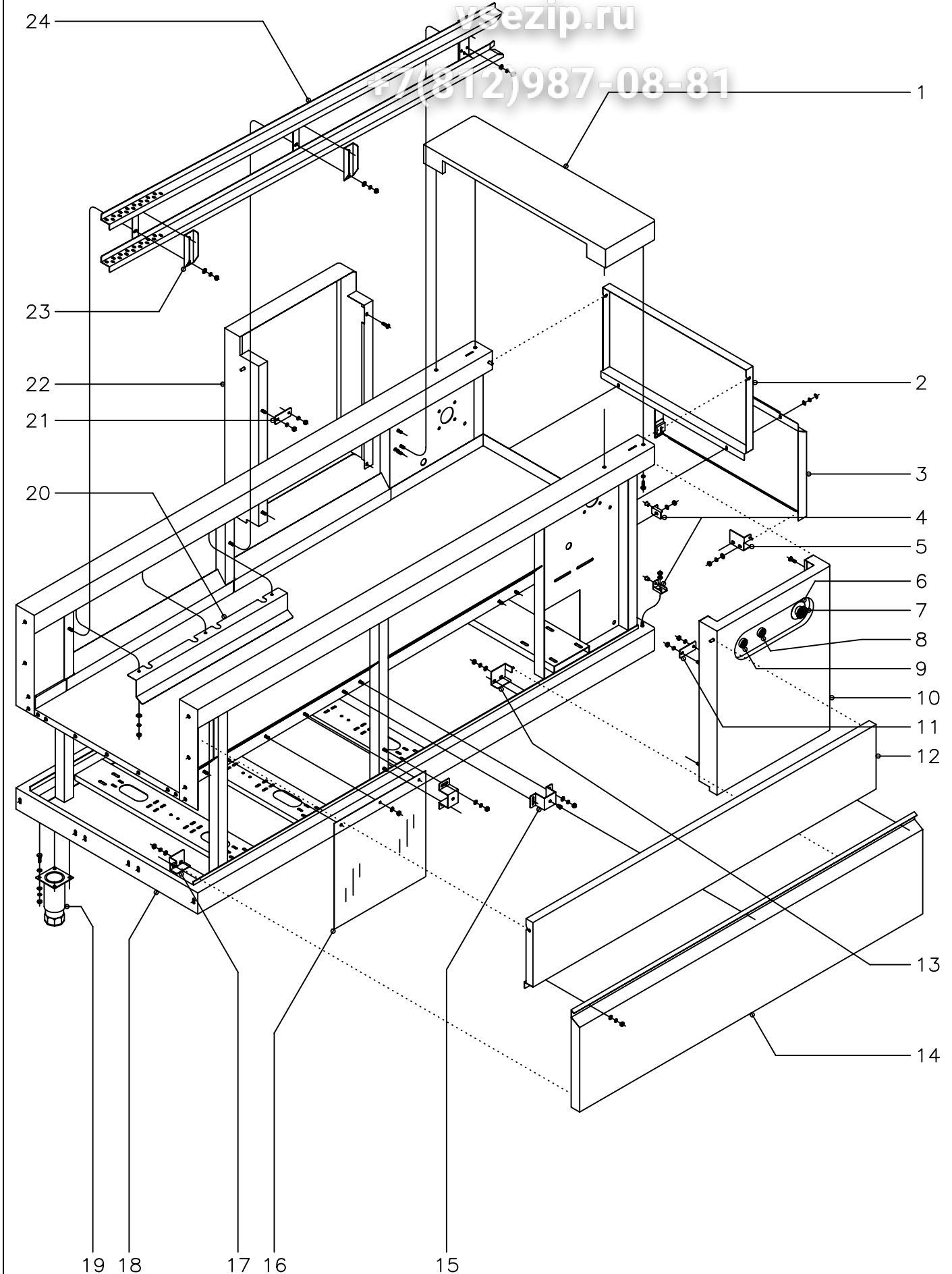

|                   |           |                 |  |              |                                       |
|-------------------|-----------|-----------------|--|--------------|---------------------------------------|
| N plano<br>C-1558 | Firma<br> | Fecha<br>7-2004 | Aparato<br>LAVAVAJILLAS DE CINTA<br>MODULO DE SALIDA | Lamina<br>14 | Fagor Industrial S.Coop. <b>FAGOR</b> |
|-------------------|-----------|-----------------|--|--------------|---------------------------------------|

# Зип Общепит

vsezip.ru

+7(812)987-08-81

| MOD. |         | LAVAVAJILLAS DE CINTA           |                               | ZONA   |        | MODULO DE SALIDA |        |  |  |
|------|---------|---------------------------------|-------------------------------|--------|--------|------------------|--------|--|--|
| ITEM | CODIGO  | DENOMINACION                    | TEXTO                         | 2700 I | 2700 D | 4000 I           | 4000 D |  |  |
| 1    | Z512942 | Tapa tope platos completa       | Complete plate buffer lid     | 1      | 1      | 1                | 1      |  |  |
|      | Q262040 | Arandela muelle A-6             | Spring washer A-6             | 4      | 4      | 4                | 4      |  |  |
|      | Q012043 | Tornillo hexagonal M-6x20       | Hexagonal screw M-6x20        | 4      | 4      | 4                | 4      |  |  |
| 2    | Z512921 | Panel lateral superior          | Upper side panel              | 1      | 1      | 1                | 1      |  |  |
| 3    | Z512919 | Panel lateral inferior completo | Complete lower side panel     | 1      | 1      | 1                | 1      |  |  |
|      | Q302022 | Arandela plana Ø16xØ6x1,2       | Flat washer Ø16xØ6x10.2       | 2      | 2      | 2                | 2      |  |  |
|      | Q262040 | Arandela muelle A-6             | Spring washer A-6             | 2      | 2      | 2                | 2      |  |  |
|      | Q162040 | Tuerca hexagonal M-6            | Hexagonal nut M-6             | 2      | 2      | 2                | 2      |  |  |
| 4    | Z512962 | Sujeción panel                  | Panel fastener                | 4      | 4      | 4                | 4      |  |  |
|      | Q302022 | Arandela plana Ø16xØ6x1,2       | Flat washer Ø16xØ6x10.2       | 4      | 4      | 4                | 4      |  |  |
|      | Q162040 | Tuerca hexagonal M-6            | Hexagonal nut M-6             | 4      | 4      | 4                | 4      |  |  |
| 5    | Z512958 | Soporte giro izquierdo completo | Complete left turn support    | 1      | 1      | 1                | 1      |  |  |
| s/n  | Z512956 | Soporte giro derecho completo   | Complete right turn support   | 1      | 1      | 1                | 1      |  |  |
|      | Q302022 | Arandela plana Ø16xØ6x1,2       | Flat washer Ø16xØ6x10.2       | 4      | 4      | 4                | 4      |  |  |
|      | Q262040 | Arandela muelle A-6             | Spring A-6 washer             | 4      | 4      | 4                | 4      |  |  |
|      | Q162040 | Tuerca hexagonal M-6            | Hexagonal nut M-6             | 4      | 4      | 4                | 4      |  |  |
| 6    | Z513006 | Etiqueta circular amarillo      | Round yellow label            | 1      | 1      | 1                | 1      |  |  |
| 7    | Z513005 | Interruptor de seta rojo        | Round mushroom switch         | 1      | 1      | 1                | 1      |  |  |
| 8    | Z513004 | Pulsador rojo completo          | Complete red push button      | 1      | 1      | 1                | 1      |  |  |
| 9    | Z513003 | Pulsador verde completo         | Complete green push button    | 1      | 1      | 1                | 1      |  |  |
| 10   | Z512902 | Panel portamandos salida comp.  | Complete control panel outlet | 1      | -      | 1                | -      |  |  |
| 10   | Z512907 | Panel portamandos salida comp.  | Complete control panel outlet | -      | 1      | -                | 1      |  |  |
|      | Q152004 | Tornillo aplastado M-5x13       | Screw M-5x13                  | 2      | 2      | 2                | 2      |  |  |
|      | Q221304 | Remache redondo M-5             | Round rivet M-5               | 4      | 4      | 4                | 4      |  |  |
| 11   | Z512961 | Amarre panel                    | Panel anchoring               | 2      | 2      | 2                | 2      |  |  |
|      | Q262040 | Arandela muelle A-6             | Spring washer A-6             | 4      | 4      | 4                | 4      |  |  |
|      | Q162040 | Tuerca hexagonal M-6            | Hexagonal nut M-6             | 4      | 4      | 4                | 4      |  |  |
| 12   | Z512914 | Panel superior salida           | Upper panel outlet            | 2      | 2      | 2                | 2      |  |  |
| 13   | Z512956 | Soporte giro derecho completo   | Complete right turn support   | 2      | 2      | 2                | 2      |  |  |

| MOD. |         | LAVAVAJILLAS DE CINTA           | ZONA                        | MODULO DE SALIDA |        |        |        |
|------|---------|---------------------------------|-----------------------------|------------------|--------|--------|--------|
| ITEM | CODIGO  | DENOMINACION                    | TEXTO                       | 2700 I           | 2700 D | 4000 I | 4000 D |
|      | Q302022 | Arandela plana Ø16xØ6x1,2       | Flat washer Ø16xØ6x10.2     | 4                | 4      | 4      | 4      |
|      | Q262040 | Arandela muelle A-6             | Spring washer A-6           | 4                | 4      | 4      | 4      |
|      | Q162040 | Tuerca hexagonal M-6            | Hexagonal nut M-6           | 4                | 4      | 4      | 4      |
| 14   | Z512912 | Panel inferior salida completo  | Complete lower panel outlet | 2                | 2      | 2      | 2      |
|      | Q302022 | Arandela plana Ø16xØ6x1,2       | Flat washer Ø16xØ6x10.2     | 6                | 6      | 6      | 6      |
|      | Q262040 | Arandela muelle A-6             | Spring washer A-6           | 6                | 6      | 6      | 6      |
|      | Q162040 | Tuerca hexagonal M-6            | Hexagonal nut M-6           | 6                | 6      | 6      | 6      |
| 15   | Z512947 | Soporte panel salida            | Outlet panel support        | 8                | 8      | 8      | 8      |
|      | Q302022 | Arandela plana Ø16xØ6x1,2       | Flat washer Ø16xØ6x10.2     | 16               | 16     | 16     | 16     |
|      | Q262040 | Arandela muelle A-6             | Spring washer A-6           | 16               | 16     | 16     | 16     |
|      | Q162040 | Tuerca hexagonal M-6            | Hexagonal nut M-6           | 16               | 16     | 16     | 16     |
|      | Q221343 | Remache hexagonal M-6           | Hexagonal rivet M-6         | 8                | 8      | 8      | 8      |
| 16   | Z513051 | Cubierta componentes eléctricos | Electric components cover   | 1                | 1      | 1      | 1      |
|      | Q302022 | Arandela plana Ø16xØ6x1,2       | Flat washer Ø16xØ6x10.2     | 3                | 3      | 3      | 3      |
|      | Q162040 | Tuerca hexagonal M-6            | Hexagonal nut M-6           | 3                | 3      | 3      | 3      |
| 17   | Z512958 | Soporte giro izquierdo completo | Complete left turn support  | 2                | 2      | 2      | 2      |
|      | Q302022 | Arandela plana Ø16xØ6x1,2       | Flat washer Ø16xØ6x10.2     | 4                | 4      | 4      | 4      |
|      | Q262040 | Arandela muelle A-6             | Spring washer A-6           | 4                | 4      | 4      | 4      |
|      | Q162040 | Tuerca hexagonal M-6            | Hexagonal nut M-6           | 4                | 4      | 4      | 4      |
| 18   | Z510440 | Salida soldada completa         | Complete welded outlet      | 1                | 1      | 1      | 1      |
| 19   | X260151 | Pata regulable                  | Ajustable leg               | 4                | 4      | 4      | 4      |
|      | Q012043 | Tornillo hexagonal M-6x20       | Hexagonal screw M-6x20      | 16               | 16     | 16     | 16     |
|      | Q302022 | Arandela plana Ø16xØ6x1,2       | Flat washer Ø16xØ6x10.2     | 32               | 32     | 32     | 32     |
|      | Q262040 | Arandela muelle A-6             | Spring washer A-6           | 16               | 16     | 16     | 16     |
|      | Q162040 | Tuerca hexagonal M-6            | Hexagonal nut M-6           | 16               | 16     | 16     | 16     |
| 20   | Z510469 | Protector fugas salida          | Escape protector outlet     | 2                | 2      | 2      | 2      |
|      | Q302022 | Arandela plana Ø16xØ6x1,2       | Flat washer Ø16xØ6x10.2     | 6                | 6      | 6      | 6      |
|      | Q262040 | Arandela muelle A-6             | Spring washer A-6           | 6                | 6      | 6      | 6      |
|      | Q162040 | Tuerca hexagonal M-6            | Hexagonal nut M-6           | 6                | 6      | 6      | 6      |

# Зип Общепит

vsezip.ru

ZONA

+7(812)987-08-81

| MOD. |         | LAVAVAJILLAS DE CINTA              | ZONA                          |        | MODULO DE SALIDA |        |        |  |
|------|---------|------------------------------------|-------------------------------|--------|------------------|--------|--------|--|
| ITEM | CODIGO  | DENOMINACION                       | TEXTO                         | 2700 I | 2700 D           | 4000 I | 4000 D |  |
| 21   | Z512961 | Amarre panel                       | Panel anchoring               | 2      | 2                | 2      | 2      |  |
|      | Q262040 | Arandela muelle A-6                | Spring washer A-6             | 4      | 4                | 4      | 4      |  |
|      | Q162040 | Tuerca hexagonal M-6               | Hexagonal nut M-6             | 4      | 4                | 4      | 4      |  |
| 22   | Z512924 | Panel posterior protector completo | Complete protector rear panel | 1      | -                | 1      | -      |  |
| 22   | Z512922 | Panel posterior protector completo | Complete protector rear panel | -      | 1                | -      | 1      |  |
|      | Q152004 | Tornillo aplastado M-5x13          | Screw M-5x13                  | 2      | 2                | 2      | 2      |  |
| 23   | Z510430 | Sujeción guía                      | Guide fastening               | 4      | 4                | 4      | 4      |  |
|      | Q302022 | Arandela plana Ø16xØ6x1,2          | Flat washer Ø16xØ6x10.2       | 8      | 8                | 8      | 8      |  |
|      | Q262040 | Arandela muelle A-6                | Spring washer A-6             | 8      | 8                | 8      | 8      |  |
|      | Q162040 | Tuerca hexagonal M-6               | Hexagonal nut M-6             | 8      | 8                | 8      | 8      |  |
| 24   | Z510461 | guía salida izquierda soldada      | Welded left outlet guide      | 1      | 1                | 1      | 1      |  |
| s/n  | Z510465 | guía salida derecha soldada        | Welded right outlet guide     | 1      | 1                | 1      | 1      |  |
|      | Q302022 | Arandela plana Ø16xØ6x1,2          | Flat washer Ø16xØ6x10.2       | 8      | 8                | 8      | 8      |  |
|      | Q262040 | Arandela muelle A-6                | Spring washer A-6             | 8      | 8                | 8      | 8      |  |
|      | Q162040 | Tuerca hexagonal M-6               | Hexagonal nut M-6             | 8      | 8                | 8      | 8      |  |
|      |         |                                    |                               |        |                  |        |        |  |
|      |         |                                    |                               |        |                  |        |        |  |
|      |         |                                    |                               |        |                  |        |        |  |
|      |         |                                    |                               |        |                  |        |        |  |
|      |         |                                    |                               |        |                  |        |        |  |
|      |         |                                    |                               |        |                  |        |        |  |
|      |         |                                    |                               |        |                  |        |        |  |
|      |         |                                    |                               |        |                  |        |        |  |
|      |         |                                    |                               |        |                  |        |        |  |
|      |         |                                    |                               |        |                  |        |        |  |
|      |         |                                    |                               |        |                  |        |        |  |
|      |         |                                    |                               |        |                  |        |        |  |
|      |         |                                    |                               |        |                  |        |        |  |
|      |         |                                    |                               |        |                  |        |        |  |
|      |         |                                    |                               |        |                  |        |        |  |
|      |         |                                    |                               |        |                  |        |        |  |
|      |         |                                    |                               |        |                  |        |        |  |
|      |         |                                    |                               |        |                  |        |        |  |
|      |         |                                    |                               |        |                  |        |        |  |



Зип Общепит

vsezip.ru

(812) 987-08-81

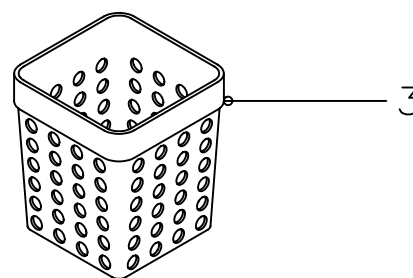
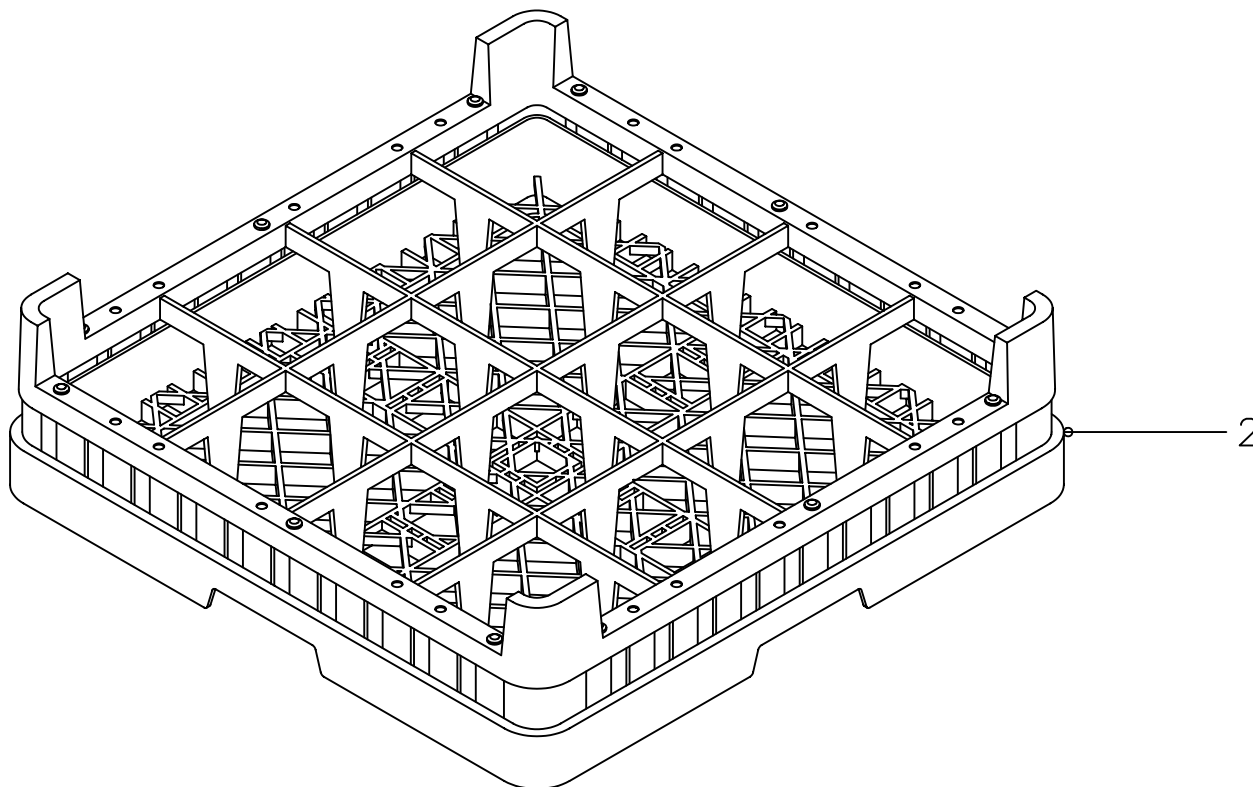
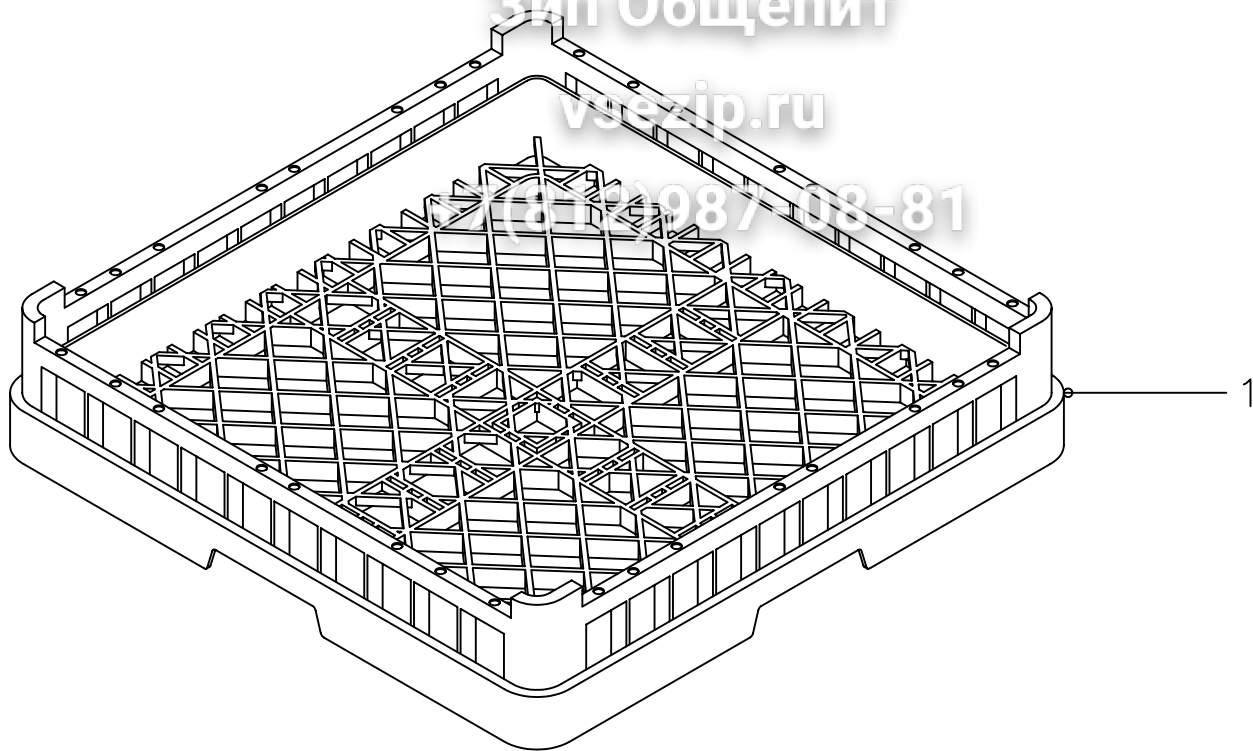

N plano  
C-1559

Firma

Fecha  
7-2004

Aparato

LAVAVAJILLAS DE CINTA  
CESTILLOS

Lamina  
15

Fagor Industrial S.Coop. **FAGOR**

Ofate

# Зип Общепит

vsezip.ru

+7(812)987-08-81

| MOD. | LAVAVAJILLAS DE CINTA | ZONA                     | CESTILLOS              |      |      |      |
|------|-----------------------|--------------------------|------------------------|------|------|------|
| ITEM | CODIGO                | DENOMINACION             | TEXTO                  | 2700 | 4000 | 6000 |
| 1    | Z655301               | Cestillo base CT-10      | Base basket CT-10      | 2    | 2    | 2    |
| 2    | Z655316               | Cestillo vasos CV-16-105 | Glass basket CV-16-105 | 2    | 2    | 2    |
| 3    | Z655314               | Cestillo cubiertos       | Cutlery basket         | 32   | 32   | 32   |
|      |                       |                          |                        |      |      |      |
|      |                       |                          |                        |      |      |      |
|      |                       |                          |                        |      |      |      |
|      |                       |                          |                        |      |      |      |
|      |                       |                          |                        |      |      |      |
|      |                       |                          |                        |      |      |      |
|      |                       |                          |                        |      |      |      |
|      |                       |                          |                        |      |      |      |
|      |                       |                          |                        |      |      |      |
|      |                       |                          |                        |      |      |      |
|      |                       |                          |                        |      |      |      |
|      |                       |                          |                        |      |      |      |
|      |                       |                          |                        |      |      |      |
|      |                       |                          |                        |      |      |      |
|      |                       |                          |                        |      |      |      |
|      |                       |                          |                        |      |      |      |
|      |                       |                          |                        |      |      |      |
|      |                       |                          |                        |      |      |      |
|      |                       |                          |                        |      |      |      |
|      |                       |                          |                        |      |      |      |
|      |                       |                          |                        |      |      |      |
|      |                       |                          |                        |      |      |      |
|      |                       |                          |                        |      |      |      |

Зип Общепит

vsezip.ru

+7(812)987-08-81

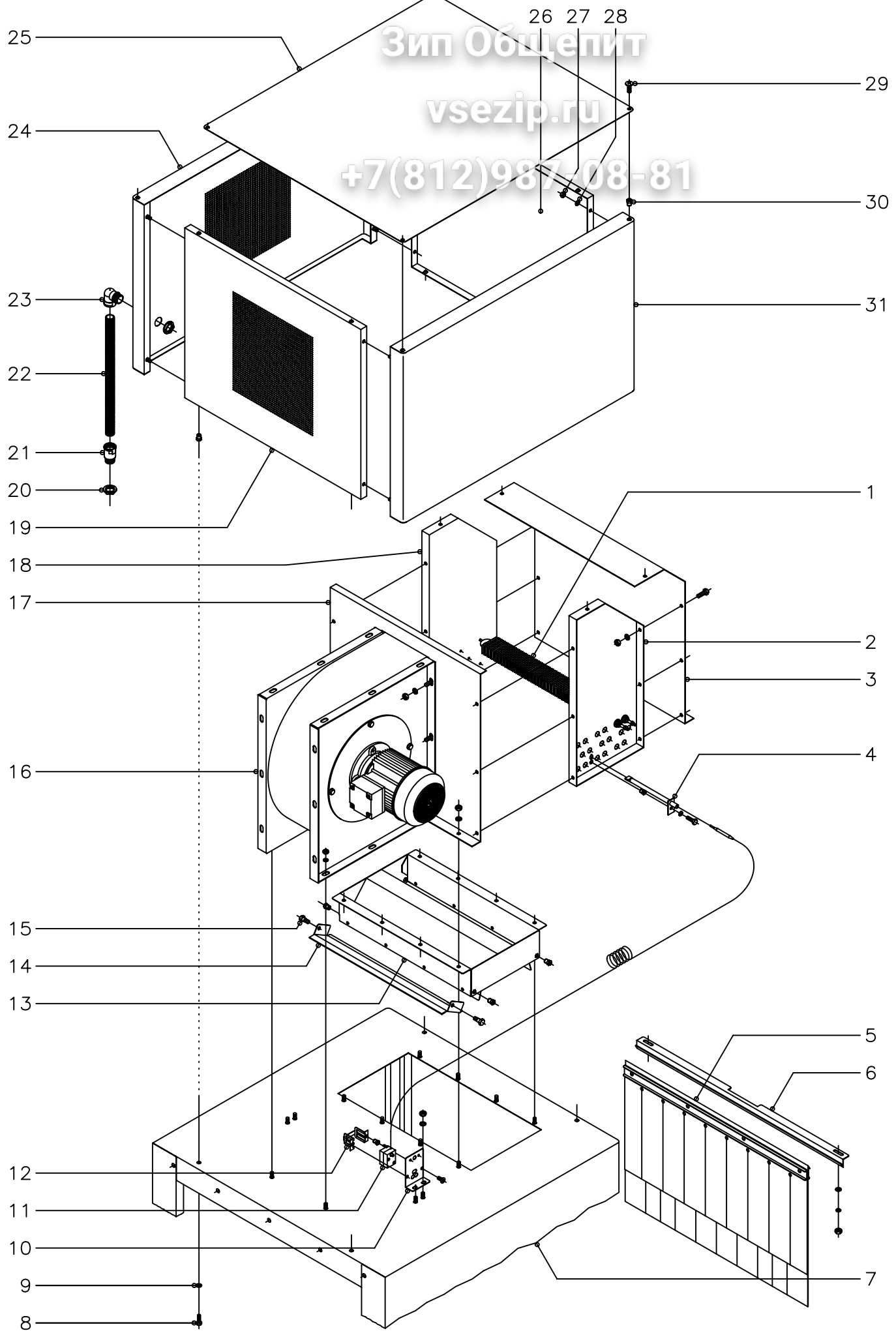

|                   |           |                 |  |              |  |
|-------------------|-----------|-----------------|--|--------------|--|
| N plano<br>C-1560 | Firma<br> | Fecha<br>7-2004 | Aparato<br>LAVAVAJILLAS DE CINTA<br>SECADO ( 800 ) | Lamina<br>16 | Fagor Industrial S.Coop. <b>FAGOR</b><br>Onate |
|-------------------|-----------|-----------------|--|--------------|--|

# Зип Ощепит

vsezip.ru

ZONA

MOD.

LAVAVAJILLAS DE CINTA

SECADO ( 800 )

+7(812)987-08-81

| ITEM | CODIGO  | DENOMINACION                        | TEXTO                          | SECADO 800 |  |  |  |  |
|------|---------|-------------------------------------|--------------------------------|------------|--|--|--|--|
| 1    | Z276391 | Resistencia aletas 1500W., 230V.    | Blade resistance 1500W., 230V. | 9          |  |  |  |  |
| 2    | Z316319 | Frontal caja resistencias           | Resistor box front             | 1          |  |  |  |  |
| 3    | Z316316 | Lateral izquierdo caja resistencias | Resistor box left side         | 1          |  |  |  |  |
|      | Q012042 | Tornillo hexagonal M-6x15           | Hexagonal screw M-6x15         | 8          |  |  |  |  |
|      | Q262040 | Arandela muelle A-6                 | Spring washer A-6              | 8          |  |  |  |  |
|      | Q162040 | Tuerca hexagonal M-6                | Hexagonal nut M-6              | 8          |  |  |  |  |
| 4    | Z276331 | Vaina para bulbo termostato         | Case for thermostat bulb       | 1          |  |  |  |  |
|      | Q012042 | Tornillo hexagonal M-6x15           | Hexagonal screw M-6x15         | 1          |  |  |  |  |
|      | Q262040 | Arandela muelle A-6                 | Spring washer A-6              | 1          |  |  |  |  |
|      | Q221343 | Remache hexagonal M-6               | Hexagonal rivet M-6            | 1          |  |  |  |  |
| 5    | Z276429 | Cortina interior completa           | Complete inner curtain         | 1          |  |  |  |  |
| 6    | Z510344 | Sujeción cortina                    | Curtain fastening              | 1          |  |  |  |  |
|      | Q232040 | Arandela plana A-6                  | Flat washer A-6                | 2          |  |  |  |  |
|      | Q262040 | Arandela muelle A-6                 | Spring washer A-6              | 2          |  |  |  |  |
|      | Q162040 | Tuerca hexagonal M-6                | Hexagonal nut M-6              | 2          |  |  |  |  |
| 7    | Z516301 | Túnel de secado completo            | Complete drying tunnel         | 1          |  |  |  |  |
| s/n  | Z516314 | Protector entrada secado            | Drying inlet protector         | 2          |  |  |  |  |
|      | Q262040 | Arandela muelle A-6                 | Spring washer A-6              | 4          |  |  |  |  |
|      | Q162040 | Tuerca hexagonal M-6                | Hexagonal nut M-6              | 4          |  |  |  |  |
| 8    | Q012042 | Tornillo hexagonal M-6x15           | Hexagonal screw M-6x15         | 4          |  |  |  |  |
| 9    | Q262040 | Arandela muelle A-6                 | Spring washer A-6              | 4          |  |  |  |  |
|      | Q221343 | Remache hexagonal M-6               | Hexagonal rivet M-6            | 4          |  |  |  |  |
| 10   | Z203047 | SopORTE termostato                  | Thermostat support             | 1          |  |  |  |  |
|      | Q232040 | Arandela plana A-6                  | Flat washer A-6                | 2          |  |  |  |  |
|      | Q162040 | Tuerca hexagonal M-6                | Hexagonal nut M-6              | 2          |  |  |  |  |
| 11   | Z213014 | Termostato limitador                | Limiter thermostat             | 1          |  |  |  |  |
| 12   | Z203060 | Amarre limitador Tecasa             | Tecasa limiter anchoring       | 1          |  |  |  |  |
|      | Q221341 | Remache hexagonal M-4               | Hexagonal rivet M-4            | 2          |  |  |  |  |
|      | Q152024 | Tornillo avellanado M-4x8           | Countersunk screw M-4x8        | 2          |  |  |  |  |

# Зип Общепит

vsezip.ru

+7(812)987-08-81

| MOD. |         | LAVAVAJILLAS DE CINTA             | ZONA                      | SECADO ( 800 ) |  |  |  |
|------|---------|-----------------------------------|---------------------------|----------------|--|--|--|
| ITEM | CODIGO  | DENOMINACION                      | TEXTO                     | SECADO 800     |  |  |  |
| 13   | Z316386 | Salida secado soldada             | Welded dryer outlet       | 1              |  |  |  |
|      | Q262040 | Arandela muelle A-6               | Spring washer A-6         | 8              |  |  |  |
|      | Q162040 | Tuerca hexagonal M-6              | Hexagonal nut M-6         | 8              |  |  |  |
| 14   | Z316388 | Tapa salida secado                | Dryer outlet lid          | 2              |  |  |  |
| 15   | Q152046 | Tornillo hexagonal con cuello     | Hexagonal screw with neck | 4              |  |  |  |
|      | Q221343 | Remache hexagonal M-6             | Hexagonal rivet M-6       | 4              |  |  |  |
| 16   | Z316331 | Ventilador centrifugo             | Centrifugal ventilator    | 1              |  |  |  |
|      | Q262040 | Arandela muelle A-6               | Spring washer A-6         | 6              |  |  |  |
|      | Q162040 | Tuerca hexagonal M-6              | Hexagonal nut M-6         | 6              |  |  |  |
| 17   | Z316336 | Lateral derecho caja resistencias | Resistor box right side   | 1              |  |  |  |
| 18   | Z316320 | Posterior caja resistencias       | Resistor box rear         | 1              |  |  |  |
|      | Q012042 | Tornillo hexagonal M-6x15         | Hexagonal screw M-6x15    | 8              |  |  |  |
|      | Q262040 | Arandela muelle A-6               | Spring washer A-6         | 8              |  |  |  |
|      | Q162040 | Tuerca hexagonal M-6              | Hexagonal nut M-6         | 8              |  |  |  |
| 19   | Z516311 | Lateral cubierta secado           | Dryer side cover          | 1              |  |  |  |
| 20   | R023025 | Contratuerca                      | Counter nut               | 2              |  |  |  |
| 21   | X713021 | Racord                            | Joint                     | 1              |  |  |  |
| 22   | 3712300 | Tubo PG-21 L=600                  | Pipe PG-21 G=600          | 1              |  |  |  |
| 23   | Z703006 | Racord a 90°                      | Joint at 90°              | 1              |  |  |  |
| 24   | Z316324 | Posterior cubierta completa       | Complete rear cover       | 1              |  |  |  |
| 25   | Z516312 | Tapa cubierta secado              | Dryer cover lid           | 1              |  |  |  |
| 26   | Z516711 | Lateral cubierta condensador      | Condenser side cover      | 1              |  |  |  |
| 27   | Q162040 | Tuerca hexagonal M-6              | Hexagonal nut M-6         | 8              |  |  |  |
| 28   | Q262040 | Arandela muelle A-6               | Spring washer A-6         | 8              |  |  |  |
| 29   | Q152017 | Tornillo amarre M-6x13            | Anchoring screw M-6x13    | 4              |  |  |  |
| 30   | Q221343 | Remache hexagonal M-6             | Hexagonal rivet M-6       | 4              |  |  |  |
| 31   | Z316322 | Anterior cubierta completa        | Complete front cover      | 1              |  |  |  |
| s/n  | Z316381 | Cableado general secado           | General dryer wiring      | 1              |  |  |  |
| s/n  | Z316353 | Cableado auxiliar secado          | Dryer auxiliary wiring    | 1              |  |  |  |

Зип Общепит

vsezip.ru

+7(812)987-08-81

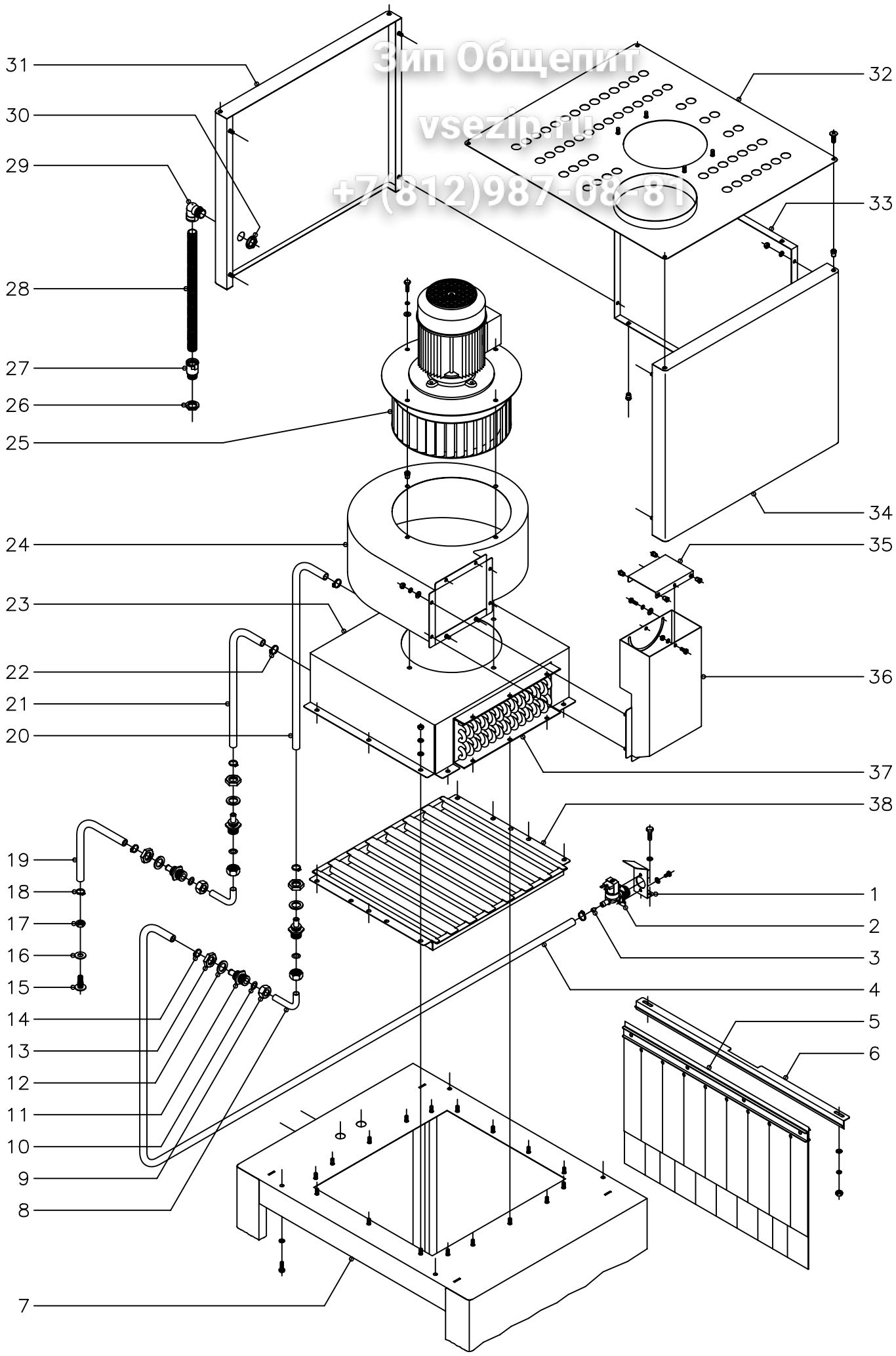

|                   |           |                 |  |              |  |
|-------------------|-----------|-----------------|--|--------------|--|
| N plano<br>C-1561 | Firma<br> | Fecha<br>7-2004 | Aparato<br>LAVAVAJILLAS DE CINTA<br>CONDENSADOR DE VAHOS | Lamina<br>17 | Fagor Industrial S.Coop. <b>FAGOR</b><br>Oñate |
|-------------------|-----------|-----------------|--|--------------|--|

# Зип Общепит

vsezip.ru

ZONA

+7(812)987-08-81

| MOD. |         | LAVAVAJILLAS DE CINTA            |                                | CONDENSADOR DE V     |  |  |
|------|---------|----------------------------------|--------------------------------|----------------------|--|--|
| ITEM | CODIGO  | DENOMINACION                     | TEXTO                          | CONDENSADOR DE VAHOS |  |  |
| 1    | Z201101 | Escuadra amarre electrovalvula   | Electrovalve anchoring bracket | 1                    |  |  |
|      | Q012042 | Tornillo hexagonal M-6x15        | Hexagonal screw M-6x15         | 2                    |  |  |
|      | Q262040 | Arandela muelle A-6              | Spring washer A-6              | 2                    |  |  |
| 2    | Z701135 | Electrovalvula simple            | Simple electrovalve            | 1                    |  |  |
|      | Q032021 | Tornillo alomado M-4x10          | Curved screw M-4x10            | 2                    |  |  |
|      | Q242020 | Arandela abanico A-4             | Fan shaped washer A-4          | 2                    |  |  |
| 3    | P443042 | Regulador caudal 3 l./min.       | Flow regulator 3 G./min.       | 1                    |  |  |
| 4    | 3676900 | Tube goma negra Ø17xØ10x5000     | Black rubber pipe Ø17xØ10x5000 | 1                    |  |  |
| 5    | Z276429 | Cortina interior completa        | Complete inner curtain         | 1                    |  |  |
| 6    | Z510344 | Sujeción cortina                 | Curtain fastening              | 1                    |  |  |
|      | Q232040 | Arandela plana A-6               | Flat washer A-6                | 2                    |  |  |
|      | Q262040 | Arandela muelle A-6              | Spring washer A-6              | 2                    |  |  |
|      | Q162040 | Tuerca hexagonal M-6             | Hexagonal nut M-6              | 2                    |  |  |
| 7    | Z516701 | Túnel condensador de vahos       | Vapour condensing tunnel       | 1                    |  |  |
| s/n  | Z516704 | Protector entrada condensador    | Condenser inlet protector      | 2                    |  |  |
|      | Q262040 | Arandela muelle A-6              | Spring washer A-6              | 4                    |  |  |
|      | Q162040 | Tuerca hexagonal M-6             | Hexagonal nut M-6              | 4                    |  |  |
| s/n  | Z516712 | Panel posterior condensador      | Condenser rear panel           | 1                    |  |  |
|      | Q152004 | Tornillo aplastado M-5x13        | Screw M-5x13                   | 2                    |  |  |
|      | Q221343 | Remache hexagonal M-5            | Hexagonal rivet M-5            | 2                    |  |  |
|      | Z512963 | Soporte panel posterior          | Rear panel support             | 2                    |  |  |
|      | Q262040 | Arandela muelle A-6              | Spring washer A-6              | 6                    |  |  |
|      | Q162040 | Tuerca hexagonal M-6             | Hexagonal nut M-6              | 6                    |  |  |
| 8    | Z516709 | Codo empalme condensador         | Condenser elbow joint          | 2                    |  |  |
| 9    | Q223108 | Tuerca M-24x2,5                  | Nut M-24x20.5                  | 4                    |  |  |
| 10   | Q307063 | Junta tórica Ø19,35xØ12,29xØ3,53 | "O" ring Ø19,35xØ12,29xØ30.53  | 4                    |  |  |
| 11   | Z271901 | Pasamuros                        | Wire protection                | 4                    |  |  |
| 12   | Q307032 | Arandela junta Ø32xØ21x3         | Joint washer Ø32xØ21x3         | 4                    |  |  |
| 13   | Q223023 | Tuerca hexagonal 5/8"            | Hexagonal nut 5/8"             | 4                    |  |  |

# Зип Общепит

vsezip.ru

ZONA

+7(812)987-08-81

| MOD. |         | LAVAVAJILLAS DE CINTA        |                                | CONDENSADOR DE V     |  |  |
|------|---------|------------------------------|--------------------------------|----------------------|--|--|
| ITEM | CODIGO  | DENOMINACION                 | TEXTO                          | CONDENSADOR DE VAHOS |  |  |
| 14   | Q881302 | Abrazadera 12 - 20           | Clamp 12 - 20                  | 2                    |  |  |
| 15   | Z600907 | Toma de presión              | Pressure point                 | 1                    |  |  |
| 16   | Z600908 | Arandela plana Ø26xØ12,5x2   | Flat washer Ø26xØ12,5x2        | 1                    |  |  |
| 17   | Q223013 | Tuerca hexagonal M-12        | Hexagonal nut M-12             | 1                    |  |  |
| 18   | Q881302 | Abrazadera 12 - 20           | Clamp 12 - 20                  | 2                    |  |  |
| 19   | 3676900 | Tubo goma negra Ø17xØ10x2000 | Black rubber pipe Ø17xØ10x2000 | 1                    |  |  |
| 20   | 3676900 | Tubo goma negra Ø17xØ10x600  | Black rubber pipe Ø17xØ10x600  | 1                    |  |  |
| 21   | 3676900 | Tubo goma negra Ø17xØ10x300  | Black rubber pipe Ø17xØ10x300  | 1                    |  |  |
| 22   | Q881302 | Abrazadera 12 - 20           | Clamp 12 - 20                  | 4                    |  |  |
| 23   | Z276741 | Cubierta batería             | Battery cover                  | 1                    |  |  |
|      | Q232040 | Arandela plana A-6           | Flat washer A-6                | 10                   |  |  |
|      | Q262040 | Arandela muelle A-6          | Spring washer A-6              | 10                   |  |  |
|      | Q162040 | Tuerca hexagonal M-6         | Hexagonal nut M-6              | 10                   |  |  |
| 24   | Z276742 | Cubierta ventola completa    | Complete ventilator cover      | 1                    |  |  |
| 25   | Z276760 | Ventilador centrifugo        | Centrifugal ventilator         | 1                    |  |  |
|      | Q012042 | Tornillo hexagonal M-6x15    | Hexagonal screw M-6x15         | 8                    |  |  |
|      | Q262040 | Arandela muelle A-6          | Spring washer A-6              | 8                    |  |  |
|      | Q302022 | Arandela plana Ø16xØ6x1,2    | Flat washer Ø16xØ6x10.2        | 8                    |  |  |
|      | Q221343 | Remache hexagonal M-6        | Hexagonal rivet M-6            | 8                    |  |  |
| 26   | R023025 | Contratuerca                 | Counter nut                    | 1                    |  |  |
| 27   | X713021 | Racord                       | Joint                          | 1                    |  |  |
| 28   | 3712300 | Tubo PG-21 L=800             | Pipe PG-21 G=800               | 1                    |  |  |
| 29   | Z703006 | Racord a 90°                 | Joint at 90°                   | 1                    |  |  |
| 30   | R023025 | Contratuerca                 | Counter nut                    | 1                    |  |  |
| 31   | Z276752 | Posterior cubierta completa  | Complete rear cover            | 1                    |  |  |
|      | Q262040 | Arandela muelle A-6          | Spring washer A-6              | 4                    |  |  |
|      | Q162040 | Tuerca hexagonal M-6         | Hexagonal nut M-6              | 4                    |  |  |
| 32   | Z516721 | Tapa cubierta completa       | Complete cover lid             | 1                    |  |  |
|      | Q152017 | Tornillo amarre M-6x13       | Anchoring screw M-6x13         | 4                    |  |  |



# Зип Общепит

vsezip.ru

ZONA

MOD.

LAVAVAJILLAS DE CINTA

CONDENSADOR DE VAHOS

+7(812)987-08-81

| ITEM | CODIGO  | DENOMINACION                       | TEXTO                           | CONDENSADOR DE VAHOS |  |  |  |
|------|---------|------------------------------------|---------------------------------|----------------------|--|--|--|
|      | Q221343 | Remache hexagonal M-6              | Hexagonal rivet M-6             | 4                    |  |  |  |
| 33   | Z516711 | Lateral cubierta condensador       | Condenser side cover            | 2                    |  |  |  |
|      | Q221343 | Remache hexagonal M-6              | Hexagonal rivet M-6             | 4                    |  |  |  |
|      | Q012042 | Tornillo hexagonal M-6x15          | Hexagonal screw M-6x15          | 4                    |  |  |  |
|      | Q262040 | Arandela muelle A-6                | Spring washer A-6               | 4                    |  |  |  |
| 34   | Z276342 | Anterior cubierta condensador      | Condenser front cover           | 1                    |  |  |  |
|      | Q262040 | Arandela muelle A-6                | Spring washer A-6               | 4                    |  |  |  |
|      | Q162040 | Tuerca hexagonal M-6               | Hexagonal nut M-6               | 4                    |  |  |  |
| 35   | Z276755 | Regulador salida aire              | Air outlet regulator            | 1                    |  |  |  |
|      | Q152047 | Tornillo cilindrico con cuello M-5 | Cylindrical screw with neck M-5 | 2                    |  |  |  |
|      | Q262030 | Arandela muelle A-5                | Spring washer A-5               | 2                    |  |  |  |
|      | Q162030 | Tuerca hexagonal M-5               | Hexagonal nut M-5               | 2                    |  |  |  |
|      | Q221343 | Remache hexagonal M-5              | Hexagonal rivet M-5             | 4                    |  |  |  |
|      | Q302022 | Arandela plana Ø16xØ6x1,2          | Flat washer Ø16xØ6x10.2         | 1                    |  |  |  |
|      | Q262030 | Arandela muelle A-5                | Spring washer A-5               | 1                    |  |  |  |
|      | Q012032 | Tornillo hexagonal M-5x15          | Hexagonal screw M-5x15          | 1                    |  |  |  |
| 36   | Z276746 | Salida aire completa               | Complete air outlet             | 1                    |  |  |  |
|      | Q232040 | Arandela plana A-6                 | Flat washer A-6                 | 8                    |  |  |  |
|      | Q262040 | Arandela muelle A-6                | Spring washer A-6               | 8                    |  |  |  |
|      | Q162040 | Tuerca hexagonal M-6               | Hexagonal nut M-6               | 8                    |  |  |  |
| 37   | Z276762 | Batería completa                   | Complete battery                | 1                    |  |  |  |
|      | Q232040 | Arandela plana A-6                 | Flat washer A-6                 | 12                   |  |  |  |
|      | Q262040 | Arandela muelle A-6                | Spring washer A-6               | 12                   |  |  |  |
|      | Q162040 | Tuerca hexagonal M-6               | Hexagonal nut M-6               | 12                   |  |  |  |
|      | Q012042 | Tornillo hexagonal M-6x15          | Hexagonal screw M-6x15          | 6                    |  |  |  |
| 38   | Z276734 | Rejilla aspiración vahos completa  | Complete vapour extractor rack  | 1                    |  |  |  |
| s/n  | Z316702 | Cableado condensador               | Condenser wiring                | 1                    |  |  |  |
|      |         |                                    |                                 |                      |  |  |  |
|      |         |                                    |                                 |                      |  |  |  |

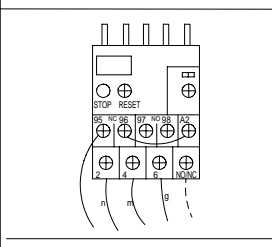
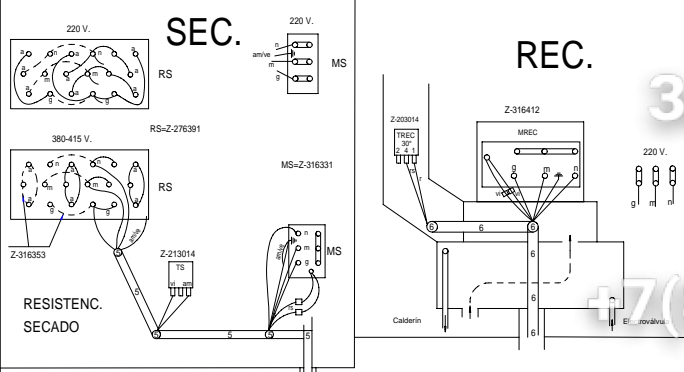

| Nº | REFERENCIA | 270 | 400 | 600 |
|----|------------|-----|-----|-----|
| 1  | Z-513031   | X   | X   | X   |
| 2  | Z-513032   | X   | X   | X   |
| 3  | Z-513033   | X   | X   | X   |
| 4  | Z-513034   | X   | X   | X   |
| 5  | Z-513038   | X   | X   | X   |
| 6  | Z-516452   | X   | X   | X   |
| 7  | Z-516702   | X   | X   | X   |
| 8  | Z-533032   | X   | X   | X   |
| 9  | Z-553032   | X   | X   | X   |

| ESQUEMAS ELECTRICOS | LEYENDA  | Indicador de Componentes |
|---------------------|----------|--------------------------|
| ECO 270             | Z-523041 | Z-33070                  |
| ECO 400             | Z-543041 | Z-33088                  |
| ECO 600             | Z-563041 |                          |
| FI-270              | Z-513041 |                          |
| FI-400              | Z-533041 |                          |
| FI-600              | Z-553041 |                          |

| RELES TERMICOS |                      |                      |
|----------------|----------------------|----------------------|
|                | 380-415 V            | 230 V                |
| FMS            | Z-516334<br>Reg. 2.6 | Z-516335<br>Reg. 4.5 |
| FMREC          | Z-123014<br>Reg. 1.4 | Z-123015<br>Reg. 2.3 |
| FMREV          | Z-123014<br>Reg. 1.4 | Z-123015<br>Reg. 2.3 |

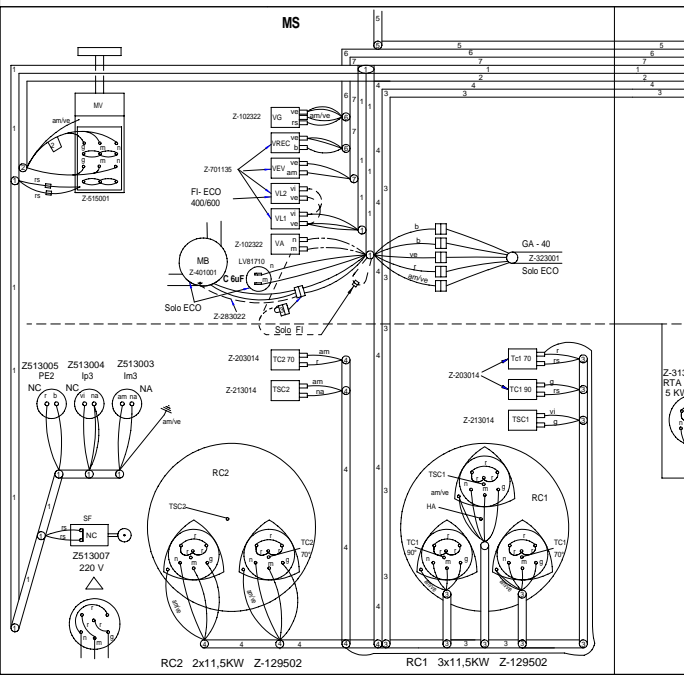
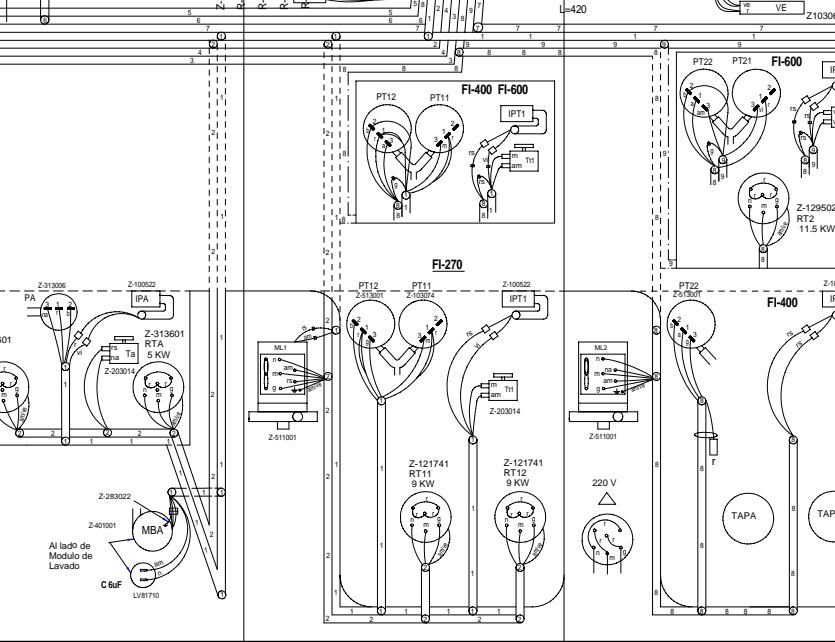
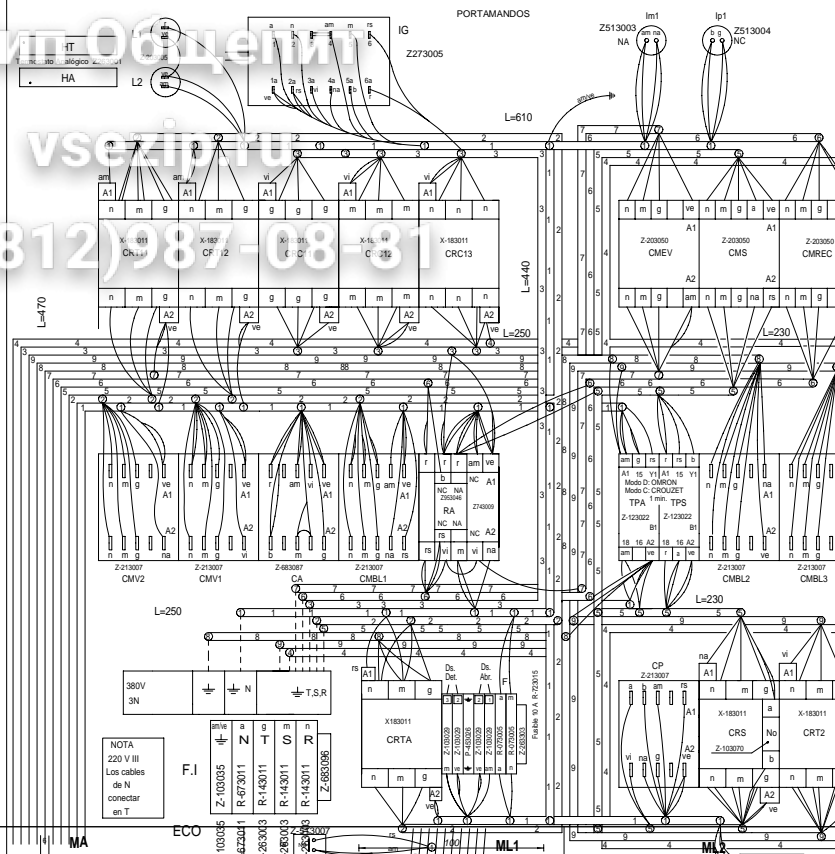

3шт. Общ. центр. все. и т.д. 7(812)387-08-31

400V 3N~

FI - 2700

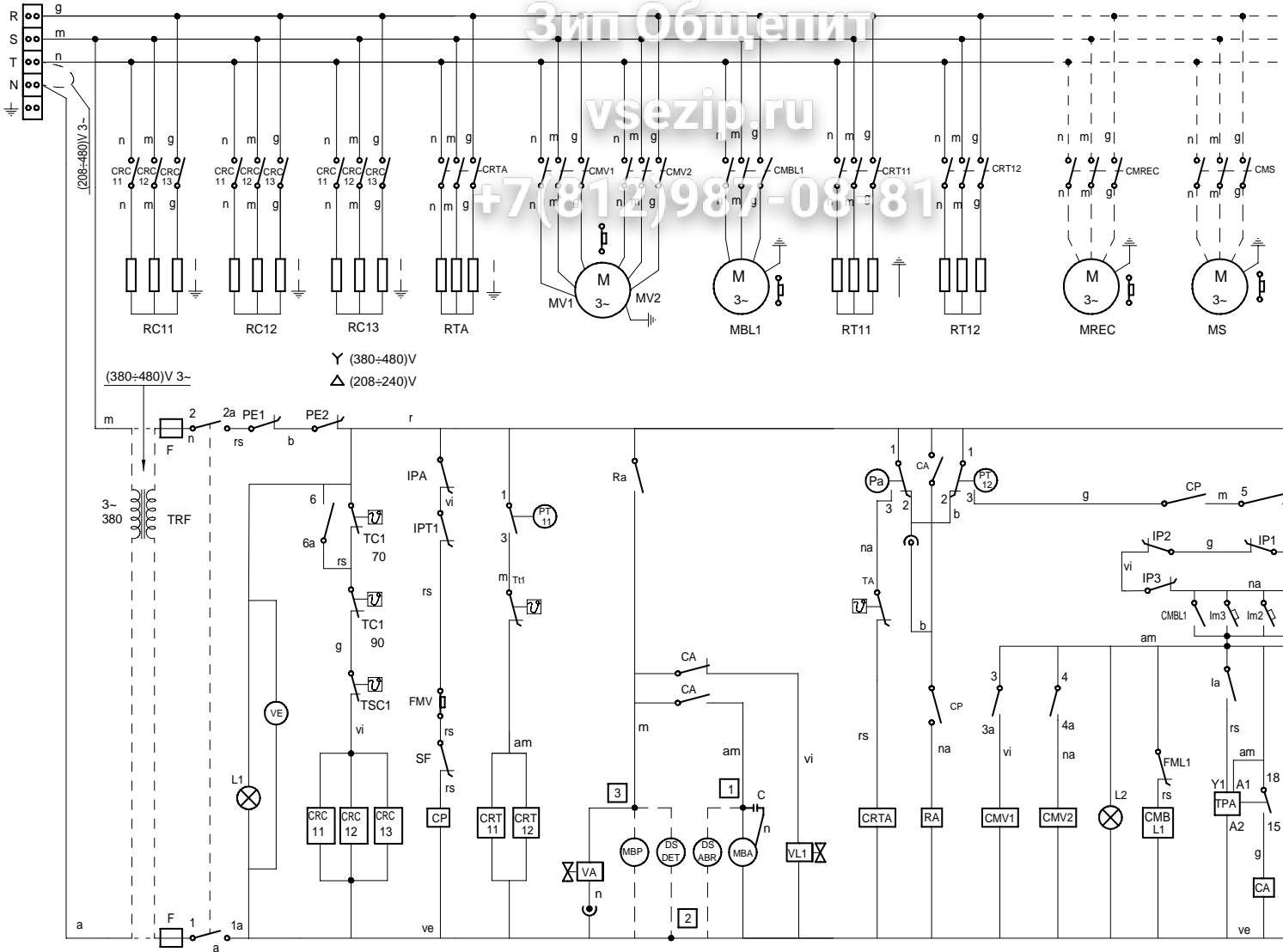

Y (380÷480)V  
 Δ (208÷240)V

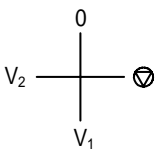

| IG             | 1<br>1a | 2<br>2a | 3<br>3a | 4<br>4a | 5<br>5a | 6<br>6a |
|----------------|---------|---------|---------|---------|---------|---------|
| 0              |         |         |         |         |         |         |
| X              | X       | X       |         |         |         |         |
| V <sub>1</sub> | X       | X       | X       |         | X       | X       |
| V <sub>2</sub> | X       | X       |         | X       | X       | X       |

|         | ESPAÑOL        | FRANÇAIS     | ENGLISH        | DEUTSCH   | ITALIANO     |
|---------|----------------|--------------|----------------|-----------|--------------|
| COLOR   | COLOR          | COULEUR      | COLOUR         | FARBEN    | COLORE       |
| a =     | Azul           | Bleu         | Blue           | Blau      | Blu          |
| am =    | Amarillo       | Jaune        | Yellow         | Gelb      | Giallo       |
| am/ve = | Amarillo/verde | Jaune / vert | Yellow / green | Gelb/grün | Giallo/verde |
| b =     | Bianco         | Blanc        | White          | Weiß      | Bianco       |
| g =     | Gris           | Gris         | Grey           | Grau      | Grigio       |
| m =     | Marrón         | Marron       | Brown          | Braun     | Marrone      |

|       | ESPAÑOL | FRANÇAIS |
|-------|---------|----------|
| COLOR | COLOR   | COULEUR  |
| n =   | Negro   | Noir     |
| na =  | Naranja | Orange   |
| r =   | Rojo    | Rouge    |
| rs =  | Rosa    | Rose     |
| ve =  | Verde   | Vert     |
| vi =  | Violeta | Violet   |

400V 3N~

FI - 4000

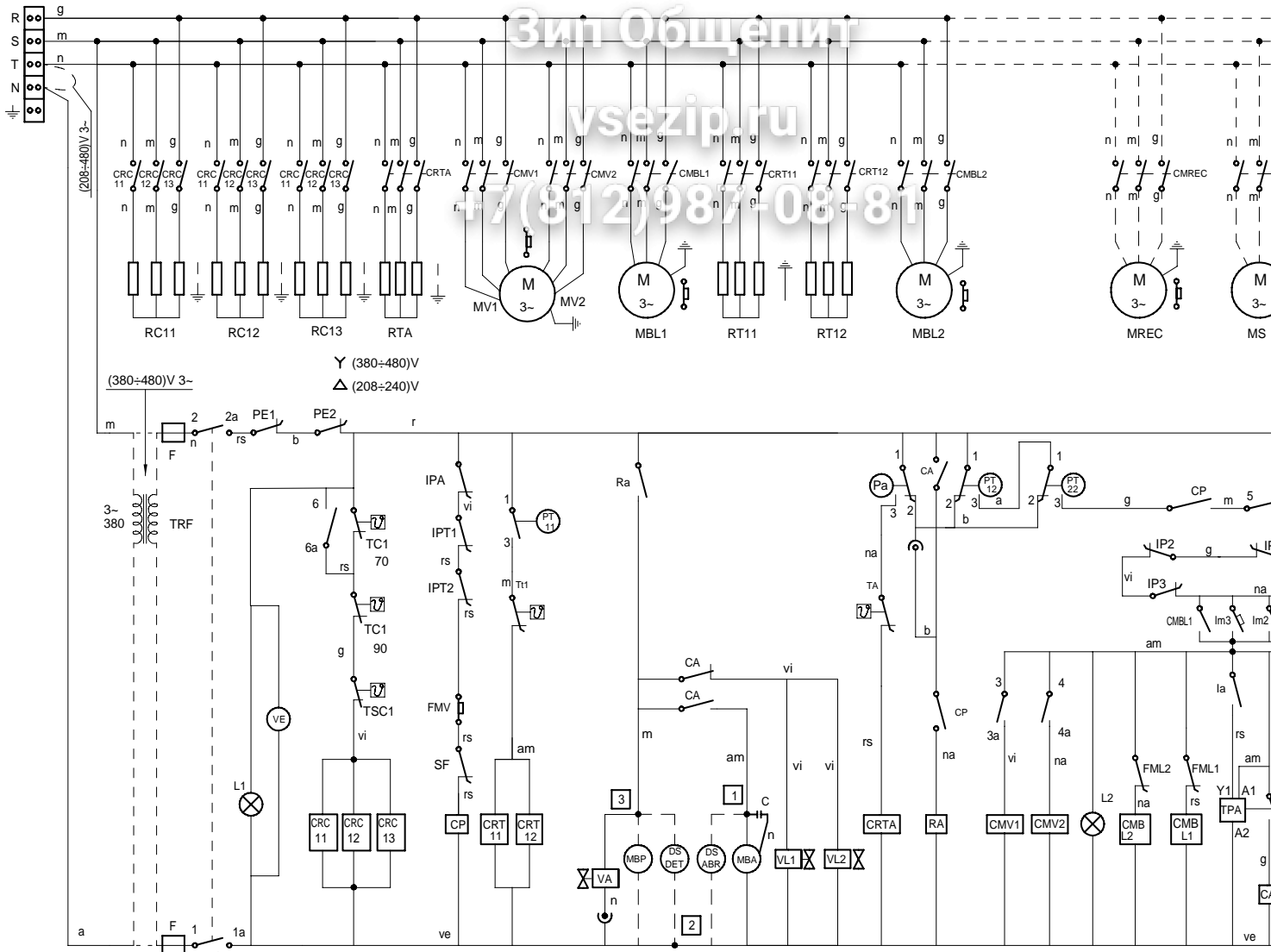

Зип Общепит  
vsezip.ru  
77(812)987-08-81

Y (380-480)V  
Δ (208-240)V

(380-480)V 3~

3~  
380V

TRF

F

|                |         |         |         |         |         |         |
|----------------|---------|---------|---------|---------|---------|---------|
| IG             | 1<br>1a | 2<br>2a | 3<br>3a | 4<br>4a | 5<br>5a | 6<br>6a |
| 0              |         |         |         |         |         |         |
| V <sub>1</sub> | X       | X       | X       |         | X       | X       |
| V <sub>2</sub> | X       | X       |         | X       | X       | X       |

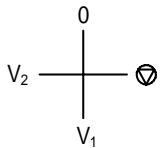

|       | ESPAÑOL          | FRANCAIS     | ENGLISH        | DEUTSCH   | ITALIANO     |       | ESPAÑOL   |
|-------|------------------|--------------|----------------|-----------|--------------|-------|-----------|
| COLOR | COLOR            | COULEUR      | COLOUR         | FARBEN    | COLORE       | COLOR | COLOR     |
| a     | = Azul           | Bleu         | Blue           | Blau      | Blu          | na    | = Naranja |
| am    | = Amarillo       | Jaune        | Yellow         | Gelb      | Giallo       | r     | = Rojo    |
| am/ve | = Amarillo/verde | Jaune / vert | Yellow / green | Gelb/grün | Giallo/verde | rs    | = Rosa    |
| b     | = Blanco         | Blanc        | White          | Weiß      | Bianco       | ve    | = Verde   |
| g     | = Gris           | Gris         | Grey           | Grau      | Grigio       | vi    | = Violeta |
| m     | = Marrón         | Marron       | Brown          | Braun     | Marrone      |       |           |

400V 3N~

FI - 6000

Зип Общепит

vsezip.ru

+7(812)987-08-81

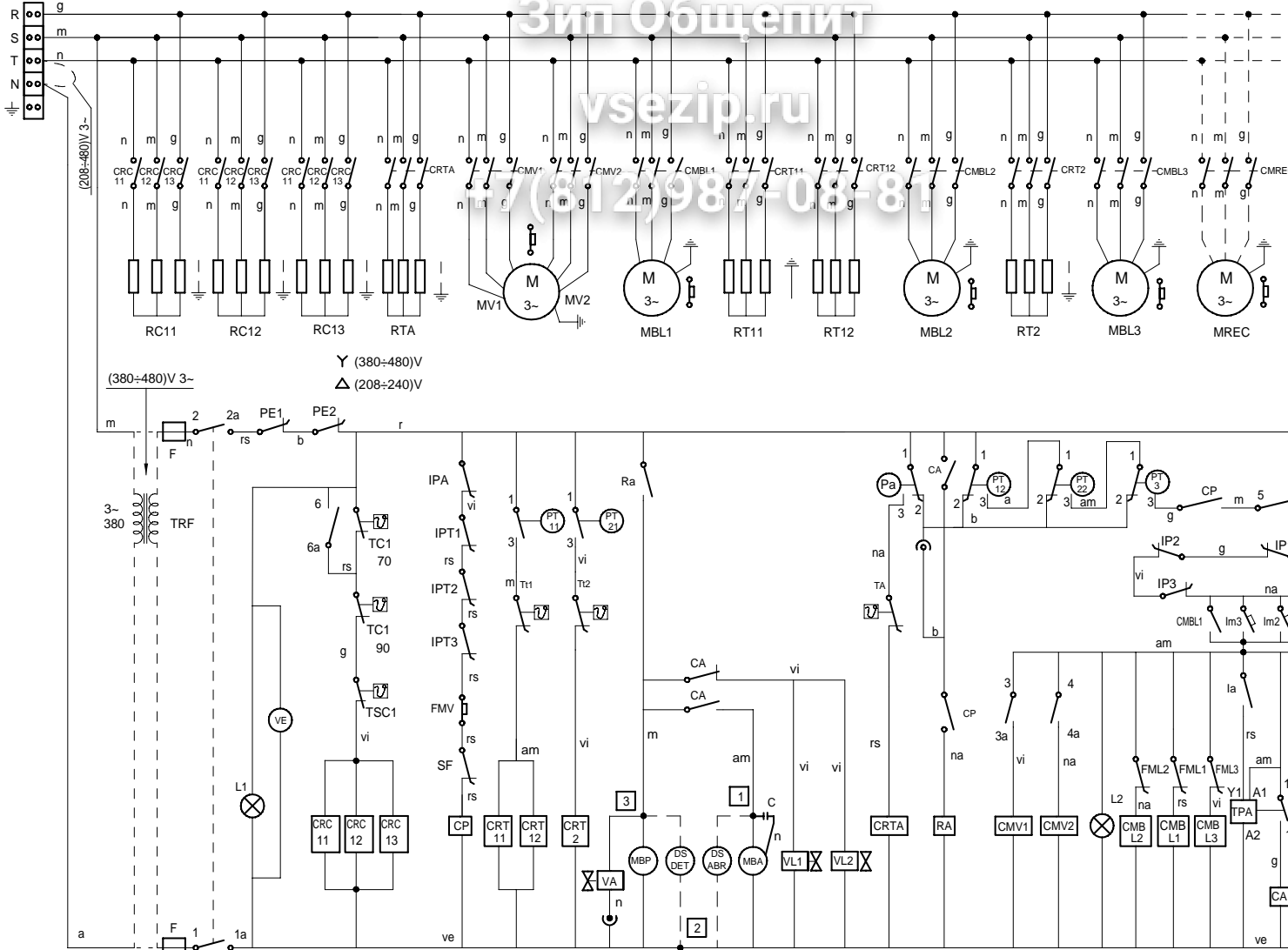

Y (380÷480)V  
 Δ (208÷240)V

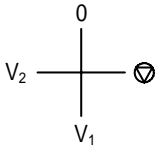

| IG | 1<br>1a | 2<br>2a | 3<br>3a | 4<br>4a | 5<br>5a | 6<br>6a |
|----|---------|---------|---------|---------|---------|---------|
| 0  |         |         |         |         |         |         |
| V1 | X       | X       |         |         | X       | X       |
| V2 | X       | X       |         | X       | X       | X       |

|         | ESPAÑOL        | FRANÇAIS     | ENGLISH        | DEUTSCH   | ITALIANO     |       | ESPAÑOL |
|---------|----------------|--------------|----------------|-----------|--------------|-------|---------|
| COLOR   | COLOR          | COULEUR      | COLOUR         | FARBEN    | COLORE       | COLOR | COLOR   |
| a =     | Azul           | Bleu         | Blue           | Blau      | Blu          | n =   | Negro   |
| am =    | Amarillo       | Jaune        | Yellow         | Gelb      | Giallo       | na =  | Naranja |
| am/ve = | Amarillo/verde | Jaune / vert | Yellow / green | Gelb/grün | Giallo/verde | r =   | Rojo    |
| b =     | Blanco         | Blanc        | White          | Weiß      | Bianco       | rs =  | Rosa    |
| g =     | Gris           | Gris         | Grey           | Grau      | Grigio       | ve =  | Verde   |
| m =     | Marrón         | Marron       | Brown          | Braun     | Marrone      | vi =  | Violeta |

400V 3N~

ECO-2700

Зип Общепит

vsezip.ru

+7(812)987-08-81

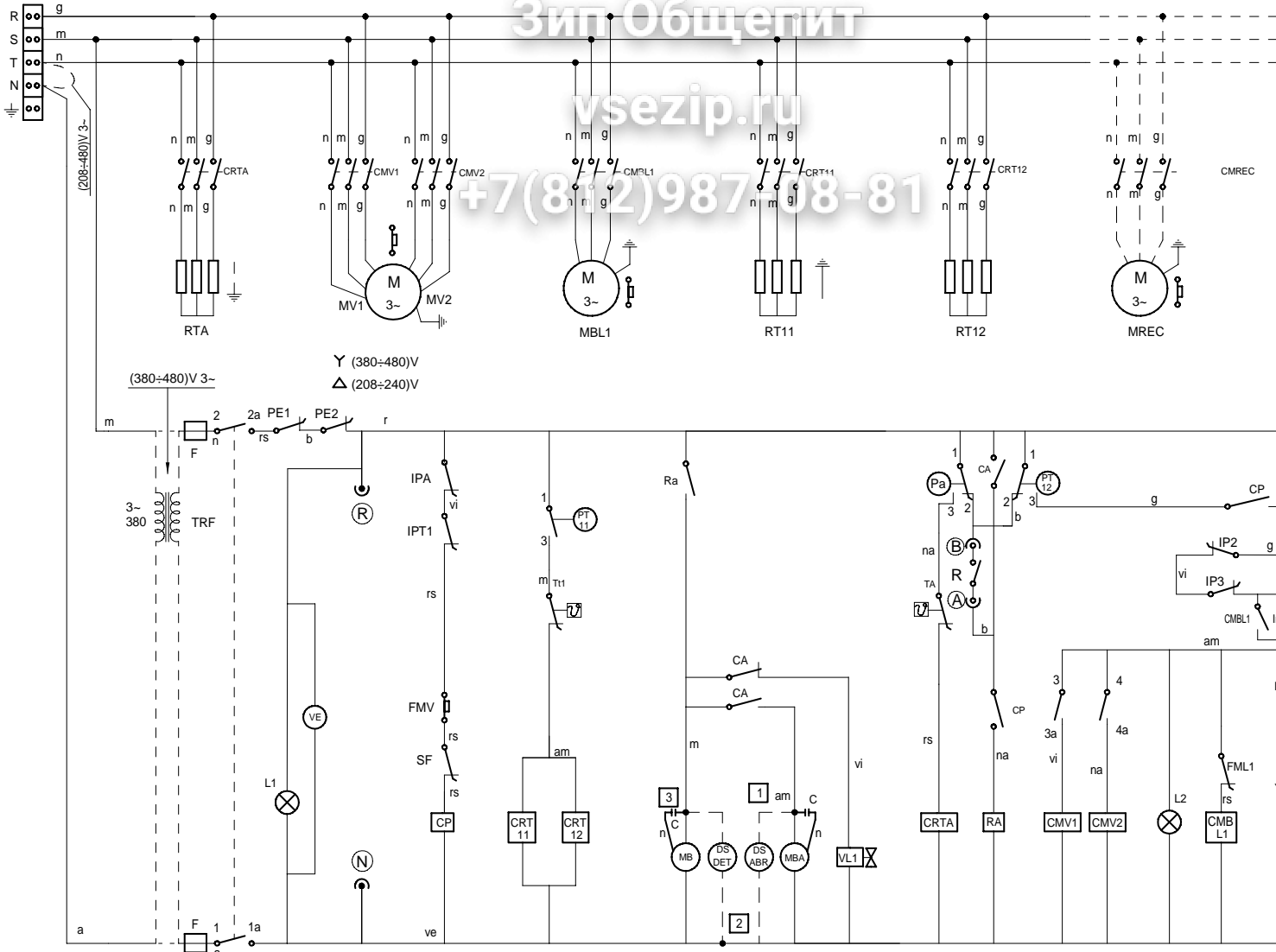

Y (380÷480)V  
 Δ (208÷240)V

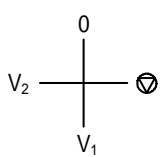

| IG             | 1<br>1a | 2<br>2a | 3<br>3a | 4<br>4a | 5<br>5a | 6<br>6a |
|----------------|---------|---------|---------|---------|---------|---------|
| 0              |         |         |         |         |         |         |
| ⊕              | X       | X       |         |         |         |         |
| V <sub>1</sub> | X       | X       | X       |         | X       | X       |
| V <sub>2</sub> | X       | X       |         | X       | X       | X       |

| COLOR   | ESPAÑOL        | FRANÇAIS     | ENGLISH        | DEUTSCH   | ITALIANO     | COLOR | ESPAÑOL |
|---------|----------------|--------------|----------------|-----------|--------------|-------|---------|
| a =     | Azul           | Bleu         | Blue           | Blau      | Blu          | n =   | Negro   |
| am =    | Amarillo       | Jaune        | Yellow         | Gelb      | Giallo       | na =  | Naranja |
| am/ve = | Amarillo/verde | Jaune / vert | Yellow / green | Gelb/grün | Giallo/verde | r =   | Rojo    |
| b =     | Bianco         | Blanc        | White          | Weiß      | Bianco       | rs =  | Rosa    |
| g =     | Gris           | Gris         | Grey           | Grau      | Grigio       | ve =  | Verde   |
| m =     | Marrón         | Marron       | Brown          | Braun     | Marrone      | vi =  | Violeta |

400V 3N~

ECO-4000

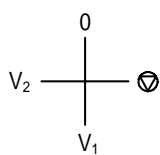
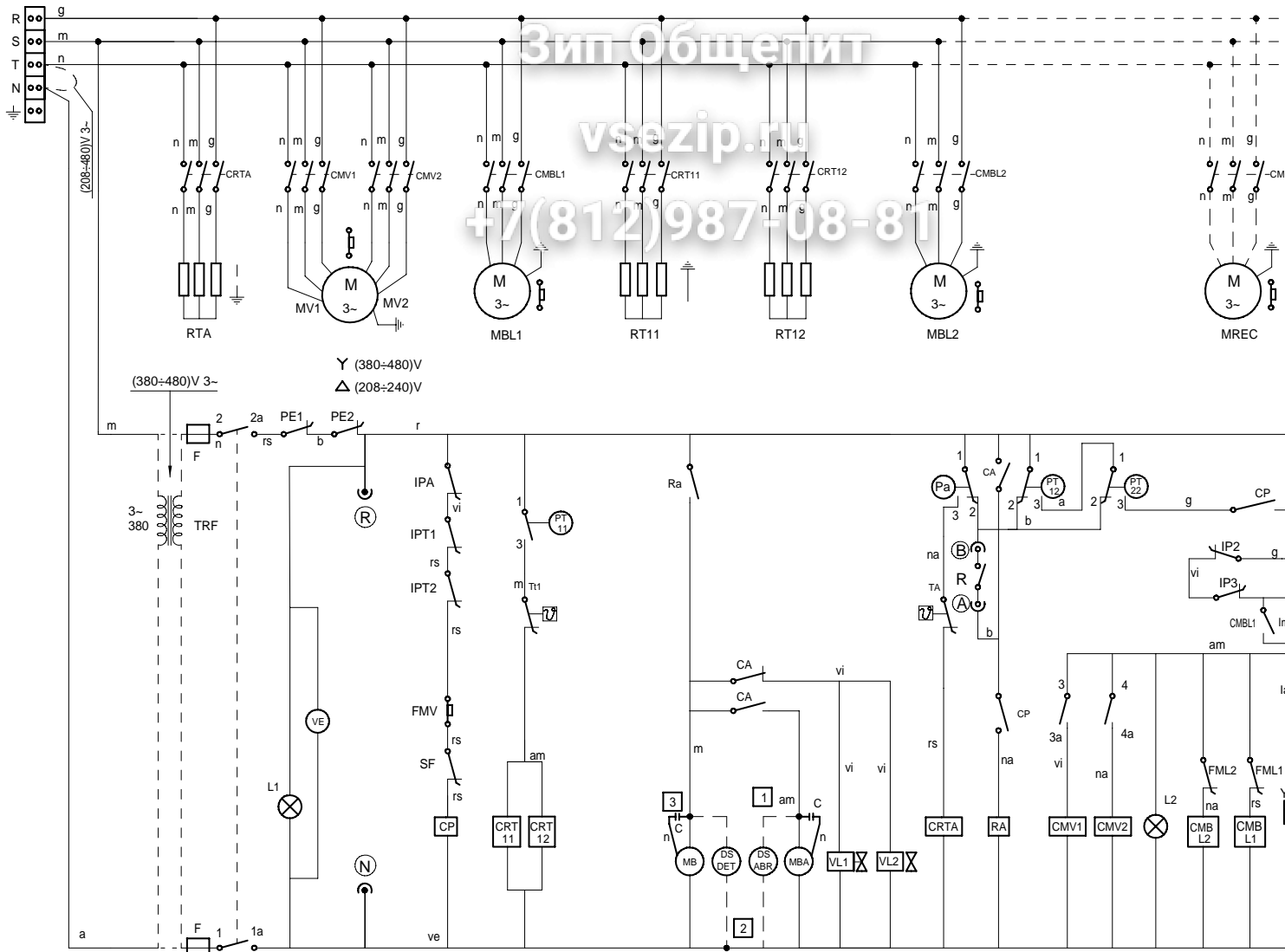

| IG             | 1<br>1a | 2<br>2a | 3<br>3a | 4<br>4a | 5<br>5a | 6<br>6a |
|----------------|---------|---------|---------|---------|---------|---------|
| 0              |         |         |         |         |         |         |
| ⊕              | X       | X       |         |         |         |         |
| V <sub>1</sub> | X       | X       | X       |         | X       | X       |
| V <sub>2</sub> | X       | X       |         | X       | X       | X       |

|         | ESPAÑOL        | FRANÇAIS     | ENGLISH        | DEUTSCH   | ITALIANO     |       | ESPAÑOL |
|---------|----------------|--------------|----------------|-----------|--------------|-------|---------|
| COLOR   | COLOR          | COULEUR      | COLOUR         | FARBEN    | COLORE       | COLOR | COLOR   |
| a =     | Azul           | Bleu         | Blue           | Blau      | Blu          | n =   | Negro   |
| am =    | Amarillo       | Jaune        | Yellow         | Gelb      | Giallo       | na =  | Naranja |
| am/ve = | Amarillo/verde | Jaune / vert | Yellow / green | Gelb/grün | Giallo/verde | r =   | Rojo    |
| b =     | Blanco         | Blanc        | White          | Weiß      | Bianco       | rs =  | Rosa    |
| g =     | Gris           | Gris         | Grey           | Grau      | Grigio       | ve =  | Verde   |
| m =     | Marrón         | Marron       | Brown          | Braun     | Marrone      | vi =  | Violeta |

400V 3N~

ECO-6000

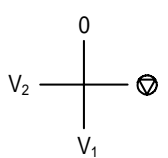
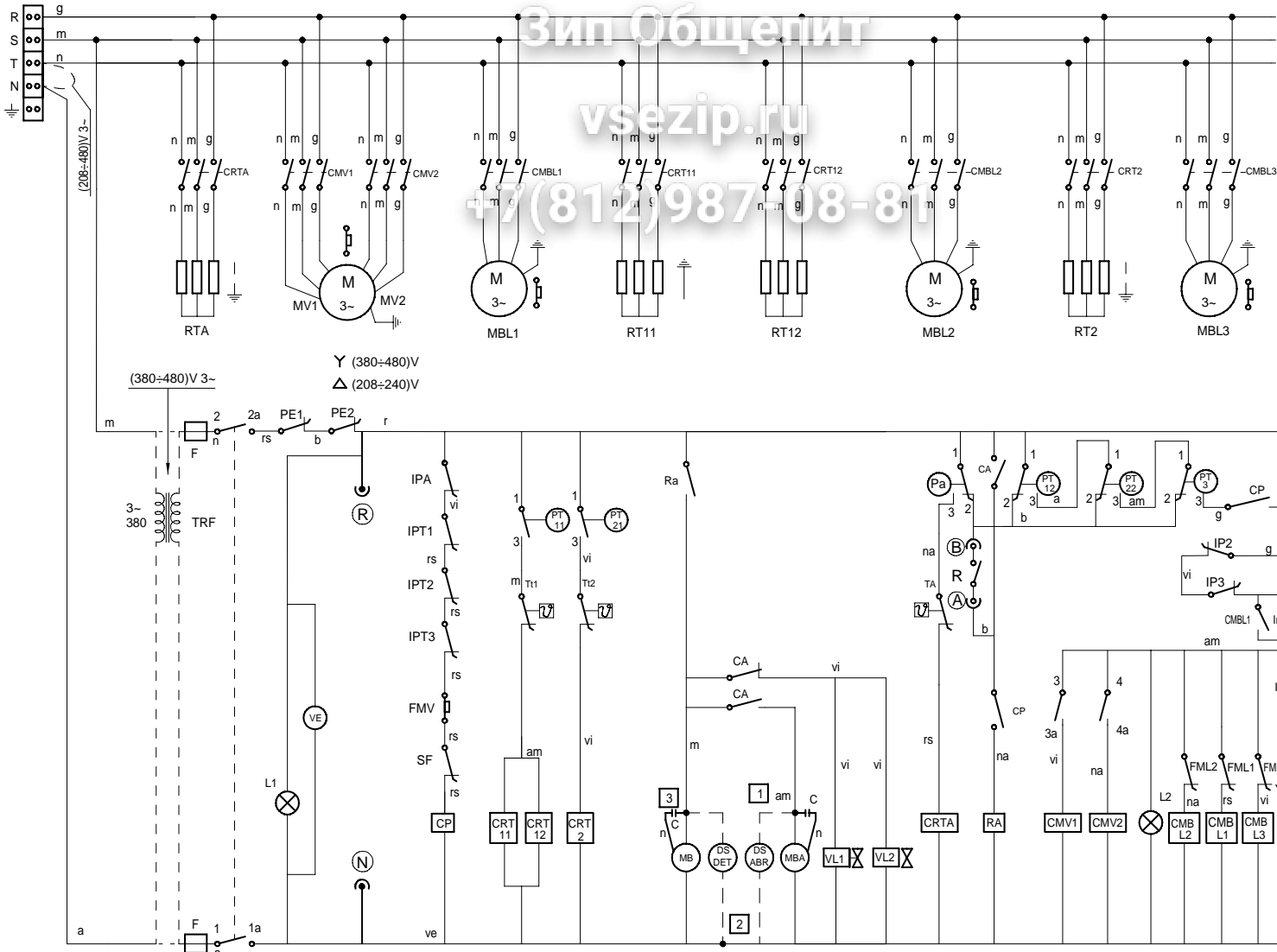

| IG             | 1<br>1a | 2<br>2a | 3<br>3a | 4<br>4a | 5<br>5a | 6<br>6a |
|----------------|---------|---------|---------|---------|---------|---------|
| 0              |         |         |         |         |         |         |
| V <sub>1</sub> | X       | X       |         |         | X       | X       |
| V <sub>2</sub> | X       | X       |         | X       | X       | X       |

|         | ESPAÑOL        | FRANÇAIS     | ENGLISH        | DEUTSCH   | ITALIANO     |       | ESPAÑOL |
|---------|----------------|--------------|----------------|-----------|--------------|-------|---------|
| COLOR   | COLOR          | COULEUR      | COLOUR         | FARBEN    | COLORE       | COLOR | COLOR   |
| a =     | Azul           | Bleu         | Blue           | Blau      | Blu          | n =   | Negro   |
| am =    | Amarillo       | Jaune        | Yellow         | Gelb      | Giallo       | na =  | Naranja |
| am/ve = | Amarillo/verde | Jaune / vert | Yellow / green | Gelb/grün | Giallo/verde | r =   | Rojo    |
| b =     | Bianco         | Blanc        | White          | Weiß      | Bianco       | rs =  | Rosa    |
| g =     | Gris           | Gris         | Grey           | Grau      | Grigio       | ve =  | Verde   |
| m =     | Marrón         | Marron       | Brown          | Braun     | Marrone      | vi =  | Violeta |



ESPAÑOL  
 (A)(B) = Puntos de conexión con R  
 (C) = Puntos de conex. 160/200 sin secado ni condensador  
 C,C1,C2 = Condensador  
 CA = Rele auxiliar aclarado  
 CMBL 1/2/3 = Contactor bomba lavado 1/2/3  
 CMBPL = Contactor bomba prelavado  
 CMEV = Contactor motor extractor  
 CMS = Contactor motor secado  
 CMV 1/2 = Contactor avance 1/2  
 CMREC = Contactor motor recuperador  
 CRC 11/12/13/21/22 = Contactor calentamiento calderin  
 CRS = Contactor resistencia secado  
 CRTA = Contactor calentamiento aclarado  
 CRT2 = Contactor calentamiento tanque 2  
 CRT11/12 = Contactor calentamiento tanque 1  
 CP = Rele puerta  
 DS.ABR = Dosificador abrillantador  
 DS.DET.= Dosificador detergente  
 F = Fusible  
 FMEV = Rele termico motor extractor  
 FML1/2/3 = S. Termico bomba lavado 1/2/3  
 FMS = Rele termico motor secado  
 FMREC = Rele termico motor recuperador  
 FMV = S. Termica motor avance  
 Ia = Micro aclarado  
 IG = Interruptor general  
 IL = Micro lavado  
 Im1/2/3 = Pulsador de marcha  
 IPA = Micro puerta aclarado  
 IP1/2/3 = Pulsador de parada  
 IPPL = Micro puerta prelavado  
 IPT1/2/3 = Micro puerta tanque 1/2/3  
 L1 = Piloto de encendido  
 L2 = Piloto marcha  
 MB = Bomba de llenado y aclarado  
 MBA = Bomba aclarado  
 MBL1/2/3 = Bomba lavado 1/2/3  
 MBP = Bomba de presion  
 MBPL = Bomba prelavado  
 MEV = Motor extractor vahos  
 MREC = Motor recuperador  
 MS = Motor secado  
 MV = Motor avance  
 Pa = Presostato aclarado  
 PE1/2 = Parada de emergencia  
 PPL = Presostato prelavado  
 PT11 = Presostato lavado 1 calentamiento  
 PT12 = Presostato lavado 1 llenado  
 PT21 = Presostato lavado 2 calentamiento  
 PT2/PT22 = Presostato lavado 2 llenado  
 PT3 = Presostato lavado 3 llenado  
 R = Rele de Generador A.C.  
 (R)(N) = Toma de alimentacion Generador A.C.  
 Ra = Rele auxiliar aclarado y llenado  
 RC11/12/13/21/22 = Resistencia calderin  
 RS = Resistencia secado  
 RTA = Resistencia calentamiento aclarado  
 RT2 = Resistencia tanque 2  
 RT11/12 = Resistencia tanque 1  
 SF = Micro fin recorrido  
 TA = Termostato aclarado  
 TC, 1/2 = Termostato calderin  
 TPA = Temporizador Aclarado  
 TPT = Temporizador inicio  
 TPS = Temporizador secado  
 TREC = Termostato recuperador  
 TRF = Transformador  
 TS = Termostato secado  
 TSC, 1/2 = Limitador calderin  
 Tt1/2 = Termostato tanque 1/2  
 VA = Electrovalvula llenado y aclarado  
 VE = Ventilador cuadro electrico  
 VEV = Electrovalvula condensacion vahos  
 VL1/2 = Electrovalvula llenado tanque  
 VG = Electrovalvula general  
 VREC = Electrovalvula salida

FRANÇAIS  
 Points de connexion R  
 Points de connexion 160/200 sans sechege ni condensateur  
 Condensateur  
 Relais auxilier rinçage  
 Contacteur pompe lavage 1/2/3  
 Contacteur pompe prelavage  
 Contacteur moteur extracteur  
 Contacteur moteur sechage  
 Contacteur avance 1/2  
 Contacteur moteur recuperateur  
 Contacteur chauff. surchauffeur  
 Contacteur resistances sechage  
 Contacteur chauffage rinçage  
 Contacteur chauffage cuve 2  
 Contacteur chauffage cuve 1  
 Relais porte  
 Dosseur de tensoactif  
 Dosseur de detergent  
 Fusible  
 Relais termique moteur extracteur  
 S. Termique pompe lavage 1/2/3  
 Relais termique moteur sechage  
 Relais termique moteur recuperateur  
 S. Termica moteur avance  
 Micro rinçage  
 Interrupteur general  
 Micro lavage  
 Bouton marche  
 Micro porte rinçage  
 Bouton arrêt  
 Micro porte prelavage  
 Micro porte cuve 1/2/3  
 Voyant fonctionnement  
 Voyant demarrage  
 Pompe remplissage rinçage  
 Pompe rinçage  
 Pompe lavage 1/2/3  
 Pompe de pression  
 Pompe prelavage  
 Moteur extracteur vapeur  
 Moteur recuperateur  
 Moteur sechage  
 Moteur avance  
 Pressostat rinçage  
 Arrêt d'urgence  
 Pressostat prelavage  
 Pressostat lavage 1 chauffage  
 Pressostat lavage 1 remplissage  
 Pressostat lavage 2 chauffage  
 Pressostat lavage 2 remplissage  
 Pressostat lavage 3 remplissage  
 Relais du Generateur  
 Alimentation generateur  
 Relais auxilier rinçage remplissage  
 Resistance surchauffeur  
 Resistance sechage  
 Resistance chauffage rinçage  
 Resistance cuve 2  
 Resistance cuve 1  
 Micro fin de coourse  
 Thermostat de rinçage  
 Thermostat surchauffeur  
 Temporisateur rinçage  
 Temporisateur demarrage  
 Temporisateur sechage  
 Thermostate recuperateur  
 Transformateur  
 Thermostat sechage  
 Thermostat limiteur surchauffeur  
 Thermostat cuve 1/2  
 Electrovanne remplissage rinçage  
 Ventilateur tableau electrique  
 Electrovanne condenseur vapeur  
 Electrovanne remplissage cuve  
 Electrovanne general  
 Electrovanne demarrage

ENGLISH  
 Conection point with R  
 Connection points 160/200 without drying nor condenser  
 Condenser  
 Rinse auxiliary relay  
 Wash pump contactor 1/2/3  
 Pre-Wash pump contactor  
 Exhaust motor contactor  
 Drying motor contactor  
 Advance contactor 1/2  
 Motor recover contactor  
 Boiler heating contactor  
 Drying heating element contactor  
 Rinse heating contactor  
 Tank heating contactor 2  
 Tank heating contactor 1  
 Door relay  
 Rinse doser  
 Detergent doser  
 Fuse  
 Thermic switch exhaust motor relay  
 Thermic switch pump 1/2/3  
 Drying motor thermic relay  
 Thermic switch recover motor  
 Thermic switch rack pulling motor  
 Rinse microswitch  
 Main switch  
 Wash microswitch  
 On pushbutton  
 Rinse door microswitch  
 Off pushbutton  
 Pre-wash door microswitch  
 Tank door microswitch 1/2/3  
 Operation light  
 Start light  
 Fill and rinse pump  
 Rinse pump  
 Wash pump 1/2/3  
 Pressure pump  
 Pre-wash pump  
 Exhaust steam motor  
 Recover motor  
 Drying motor  
 Motor advance  
 Rinse level switch  
 Emergency stop  
 Pre-wash level switch  
 Wash level 1 and heating switch  
 Wash level 1 and fill switch  
 Wash level 2 and heating switch  
 Wash level 2 and fill switch  
 Wash 3 fill pressostat  
 Generator rele  
 Water heater feeding  
 Rinse and fill auxiliary relay  
 Boiler heating element  
 Drying heating element  
 Rinse heating heater  
 Tank heater 2  
 Tank heater 1  
 Safety end switch  
 Rinse thermostat  
 Boiler thermostat  
 Rinsing timer  
 Start timer  
 Drying timer  
 Recover thermostat  
 Trasformer  
 Drying thermostat  
 Boiler Hi-limit thermostat  
 Tank thermostat 1/2  
 Fill and rinse valve  
 Switchboard fan  
 Exhaust condenser solenoide valve  
 Tank fill valve  
 Main valve  
 Outlet solenoide valve

DEUTSCH  
 Anschlusspunkte mit R  
 Anschlusspunkte 160/200 weder ohne  
 Kondensator  
 Hilfsrelais Spülen  
 Kontaktschütz Waschpumpe  
 Kontaktschütz Vorwaschpumpe  
 Kontaktschütz Abzugsmotor  
 Kontaktschütz Trocknungsmotor  
 Kontaktschütz Vorlauf 1/2  
 Kontaktschütz Rekuperatormotor  
 Kontaktschütz Boilerheizung  
 Kontaktschütz Trocknungsheizung  
 Kontaktschütz Spülheizung  
 Kontaktschütz Heizung Tank  
 Kontaktschütz Heizung Tank  
 Türrelais  
 Dosierer Glanzmittel  
 Dosierer Spülmittel  
 Sicherung  
 Thermorelais Abzugsmotor  
 Thermoschalter Waschpumpe  
 Thermorelais Trocknungsmotor  
 Thermorelais Rekuperatormotor  
 Thermoschalter Vorlaufmotor  
 Mikroschalter Spülen  
 Hauptschalter  
 Mikroschalter Waschen  
 Betriebstaster  
 Mikroschalter Tür Spülen  
 Aus-Taster  
 Mikroschalter Tür Vorwaschen  
 Mikroschalter Tür Tank 1/2/3  
 Betriebsanzeigelampe  
 Startanzeigelampe  
 Füll-und Spülpumpe  
 Spülpumpe  
 Waschpumpe 1/2/3  
 Druckpumpe  
 Vorwaschpumpe  
 Motor Dampfzug  
 Rekuperatormotor  
 Trocknungsmotor  
 Vorlaufmotor  
 Druckregler Spülen  
 Not-Aus  
 Druckregler Vorwaschen  
 Druckregler Waschstufe 1 Heiz  
 Druckregler Waschstufe 1 Füll  
 Druckregler Waschstufe 2 Heiz  
 Druckregler Waschstufe 2 Füll  
 Druckwächter Spülgang 3 Füll  
 Relais Generator  
 Stromversorgungsanschluss Generator  
 Hilfsrelais Spülen und Füllen  
 Boilerheizwiderstand  
 Heizwiderstand Trocknen  
 Heizwiderstand Spülen  
 Heizwiderstand Tank 2  
 Heizwiderstand Tank 1  
 Mikroschalter Zyklusende  
 Thermostat zum Spülen  
 Thermostat kessel  
 Zeitschaltuhr Spülgang  
 Start-Timer  
 Trocknungs-Timer  
 Rekuperator-Timer  
 Transformator  
 Trocknungsthermostat  
 Grenzthermostat Boiler  
 Thermostat Tank 1/2  
 Elektroventil Füllen und Spülen  
 Schalttafelventilator  
 Elektroventil Dampfkondensator  
 Elektroventil Tankfüllung  
 Hauptelektroventil  
 Ausgangelektroventil