

3 ил Обслуживания Spare Parts List

vsezip.ru

DISKMASKIN

DISHWASHER 87-08-81

GESCHIRRRSPÜLMASCHINE

Produktnummer Product number Produktnummer	Spänning Voltage Spannung	Effekt Loading Leistung	Vattentemp. °C Water temp. °C Wassertemp. °C	Torkmedelsdosering Drying agent injector Trockenmittelinjektor	Anm. Notes Anm.
Isolerad modell - Non insulated model - Nicht isolierte Modelle					
975 88 01-02	380V 3N 50	9,0 kW	55-65	x	
975 88 02-01	220V 3 50	13,5 kW	55-65		
975 88 08-01	380V 3 50	9,0 kW	55-65	x	
975 88 09-01	440V 3 60	9,0 kW	55-65	x	
97 60 03 03-01	380V 3N 50	13,5 kW	5-20	x	
97 60 03 05-01	415V 3N 50	13,5 kW	5-20	x	
97 60 03 06-01	380V 3N 50	13,5 kW	5-20	x	
97 60 03 09-01	200V 3 50	9,9 kW	55-65		
97 60 03 10-01	200V 3 60	9,9 kW	55-65		
97 60 03 24-01	380V 3N 50	13,5 kW	5-20	x	
97 60 03 25-02	380V 3N 50	13,5 kW	5-20	x	
97 60 03 30-01	200V 3 50	9,9 kW	55-65		
97 60 03 31-01	200V 3 60	9,9 kW	55-65		
97 60 03 35-01	400V 3N 50	13,5 kW	55-65		
97 60 03 36-01	220V 3 50	13,5 kW	55-65		
97 60 03 40-01	380V 3N 50	9,0 kW	55-65	x	
97 60 03 41-01	380V 3N 50	13,5 kW	5-20	x	
Isolerad modell - Insulated model - Isolierte Modelle					
975 88 21-02	380V 3N 50	9,0 kW	55-65	x	1)
975 88 22-01	220V 3 50	13,5 kW	55-65		1)
975 88 23-01	380V 3N 50	13,5 kW	5-20	x	1)
97 60 04 05-01	380V 3N 50	13,5 kW	5-20	x	1)
97 60 04 19-01	380V 3N 50	9,0 kW	55-65	x	1)
97 60 04 22-02	380V 3N 50	13,5 kW	5-20	x	1)
97 60 04 31-02	380V 3N 50	9,0 kW	55-65	x	1)
97 60 04 32-01	380V 3N 50	9,0 kW	55-65	x	1)
97 60 04 35-01	400V 3N 50	13,5 kW	55-65		1)
97 60 04 36-01	220V 3 50	13,5 kW	55-65		1)
97 60 04 37-01	380V 3N 50	13,5 kW	5-20	x	1)
97 60 04 38-01	380V 3N 50	9,0 kW	55-65	x	1)
97 60 04 39-01	380V 3N 50	6,1 kW	55-65	x	1)
97 60 05 01-01	380V 3N 50	9,0 kW	55-65	x	1)
97 60 05 01-02	380V 3N 50	9,0 kW	55-65	x	1)
97 60 05 02-02	380V 3N 50	9,0 kW	55-65	x	

1) Utvändig fjädersystem - Outside spring system - Auswendig Federsystem

Sida Page Seite	Innehåll	Contents	Inhalt
3	Huv	Hood	Haube
5-9	Spösystem	Rinsing system	Spüsystem
11	Stativ och plåtar	Base and panels	Gestell und Blech
13	Pump och avlopp	Pump and drain	Pumpe und Ablauf
15-17	El. detaljer	El. details	El. Komponenten
19-21	Genomströmare	Booster heater	Durchlauferhitzer
23	Pump	Pump	Pumpe
25-29	Utvändig fjädersystem	Outside spring system	Auswendig Federsystem
30-61	Unika detaljer/ produkt nummer	Unique parts/ product number	Einzige Teile/ Produkt nummer

Зип Ощепит

vsezip.ru

+7(812)987-08-81

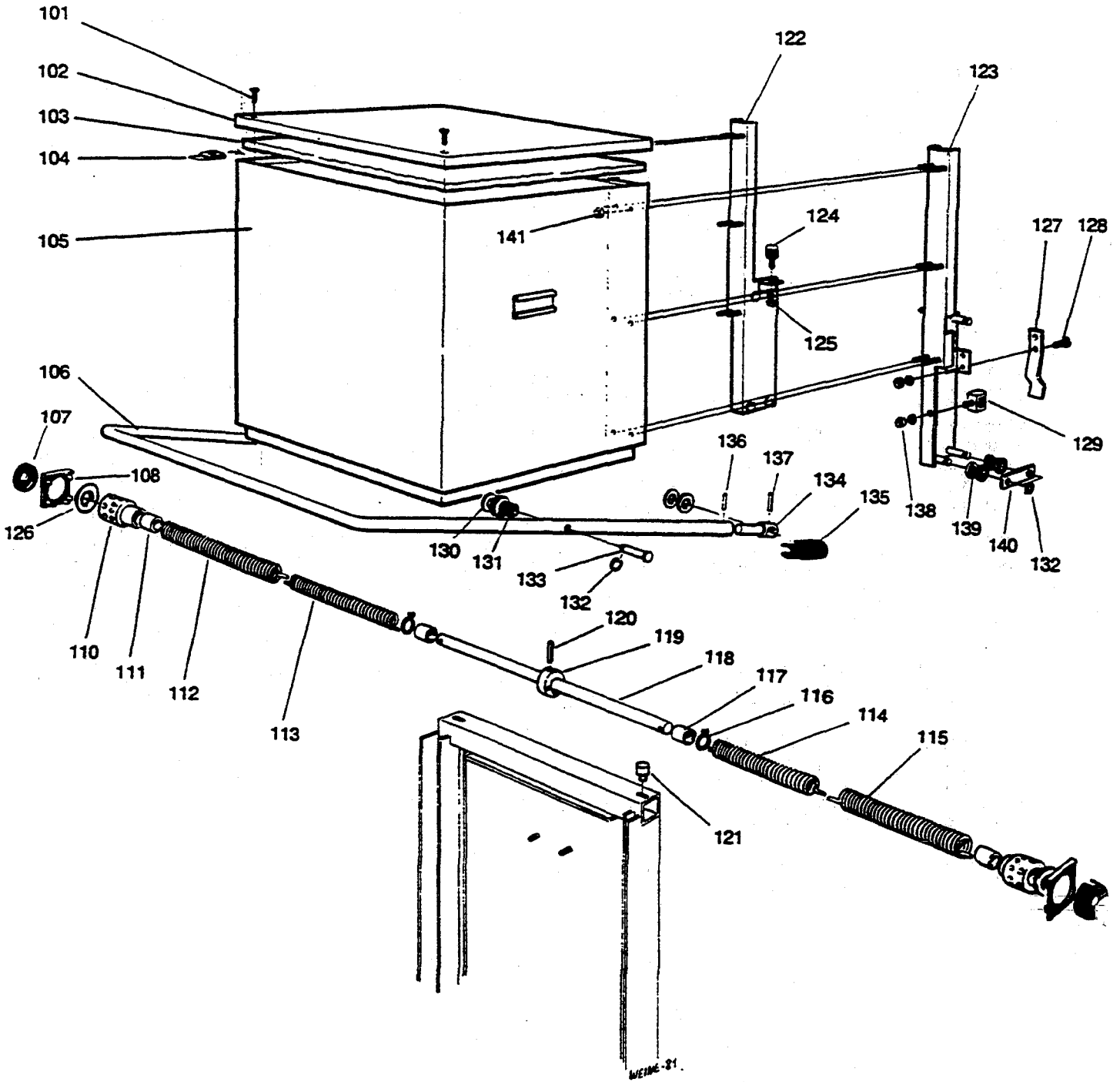

Зип Общепит

vsezip.ru

+7(812)987-08-81

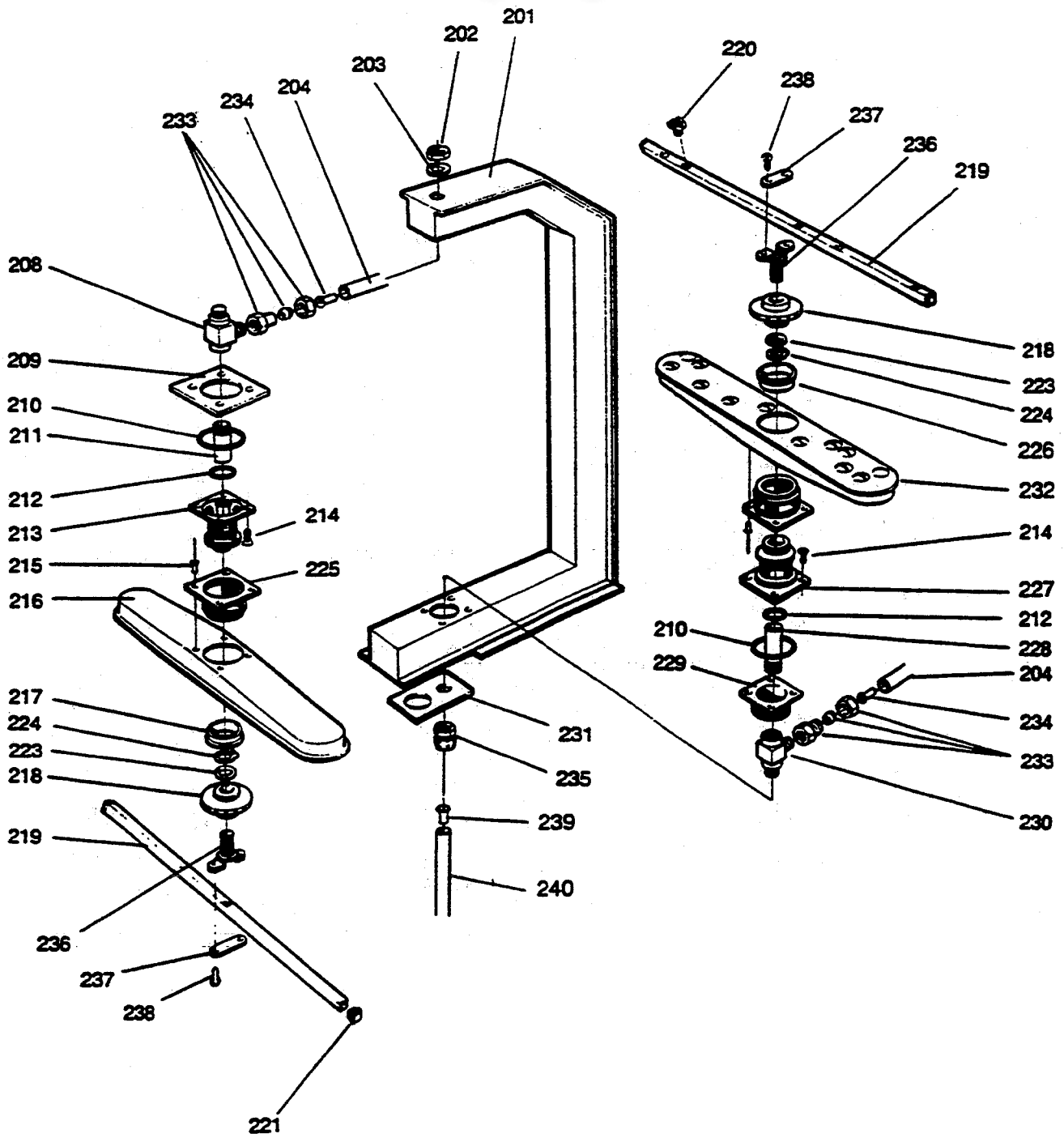

Prod. no.
97 60 04 39-01

Зип Общепит

vsezip.ru

+7(812)987-08-81

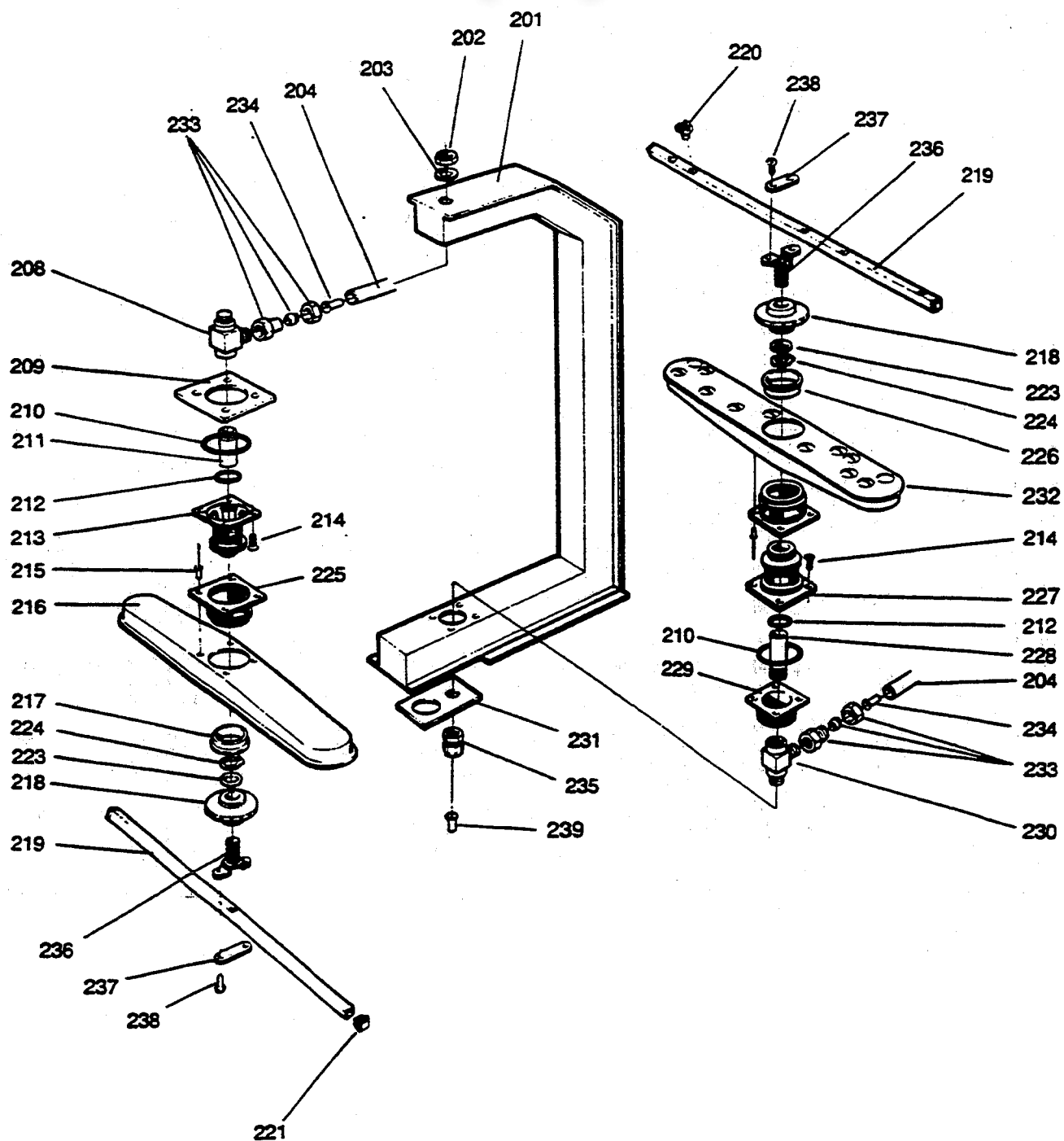

Prod. no.
97 60 03 25-02
97 60 04 22-02

Зип Общепит

vsezip.ru

+7(812)987-08-81

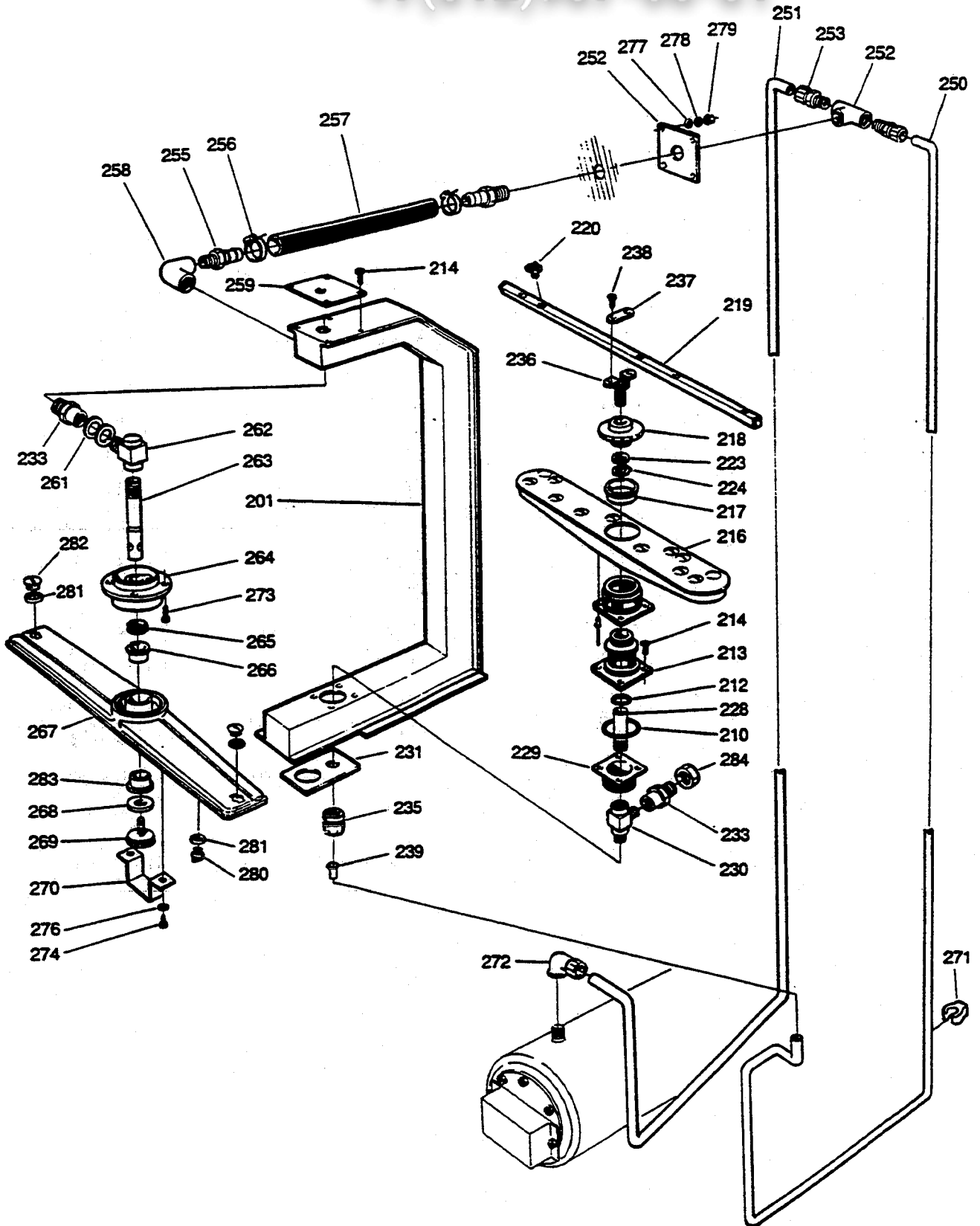

Зип Общепит

vsezip.ru

+7(812)987-08-81

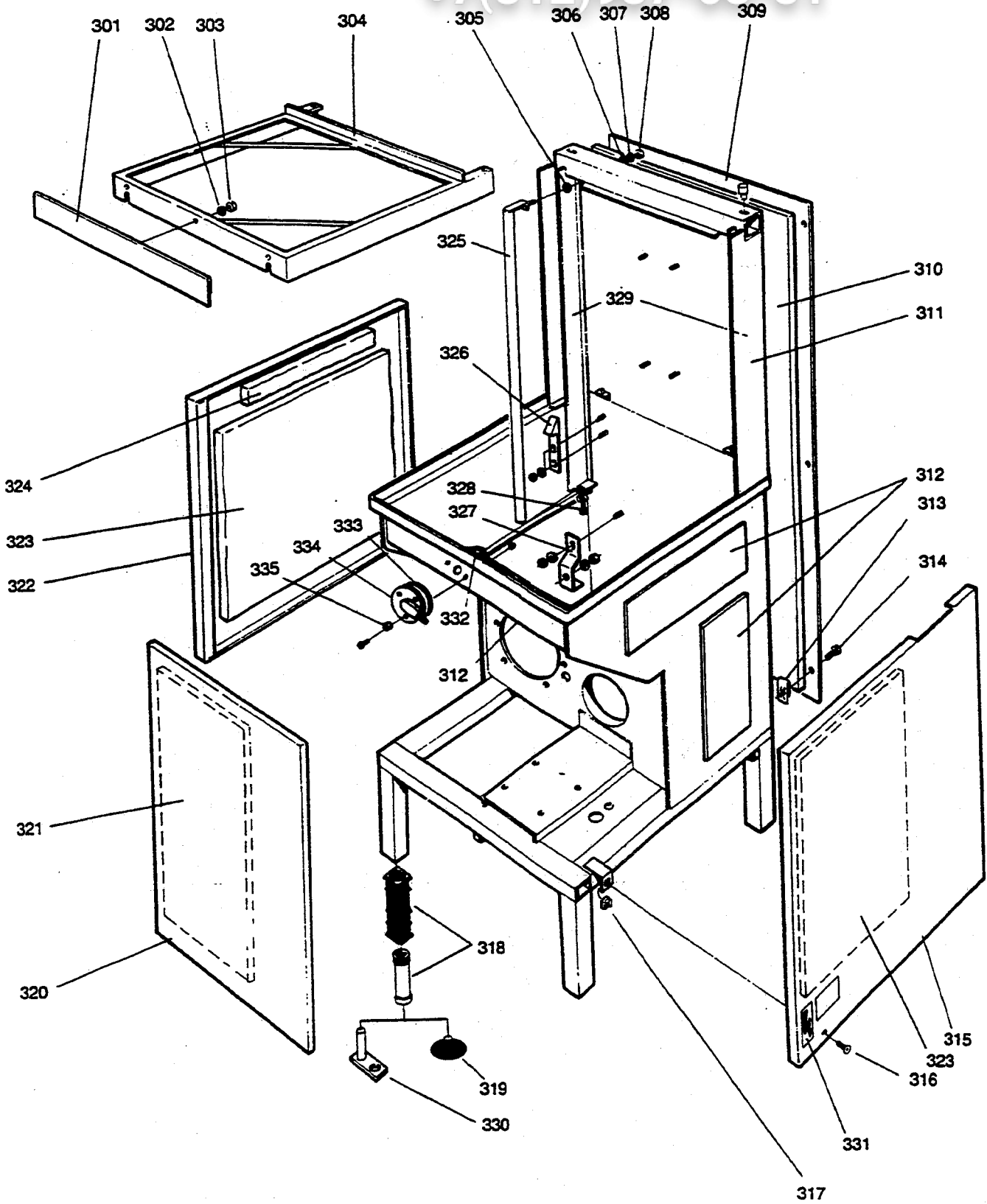

Зип Общепит

vseip.ru

+7(812)987-08-81

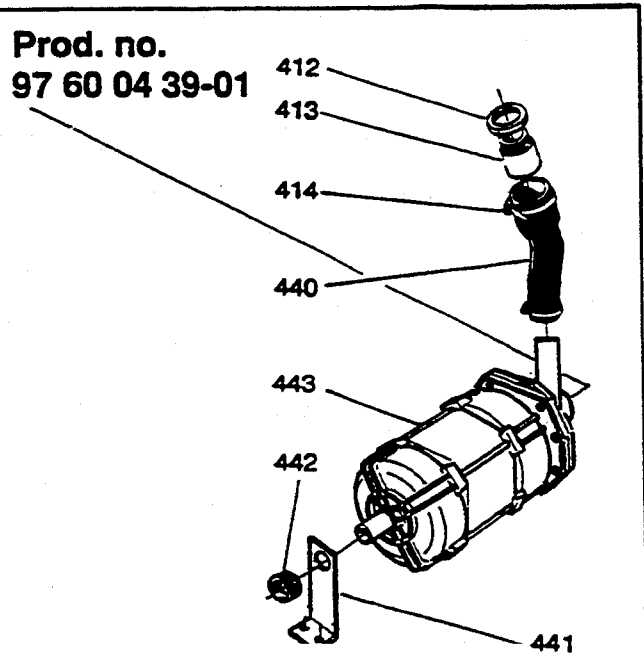
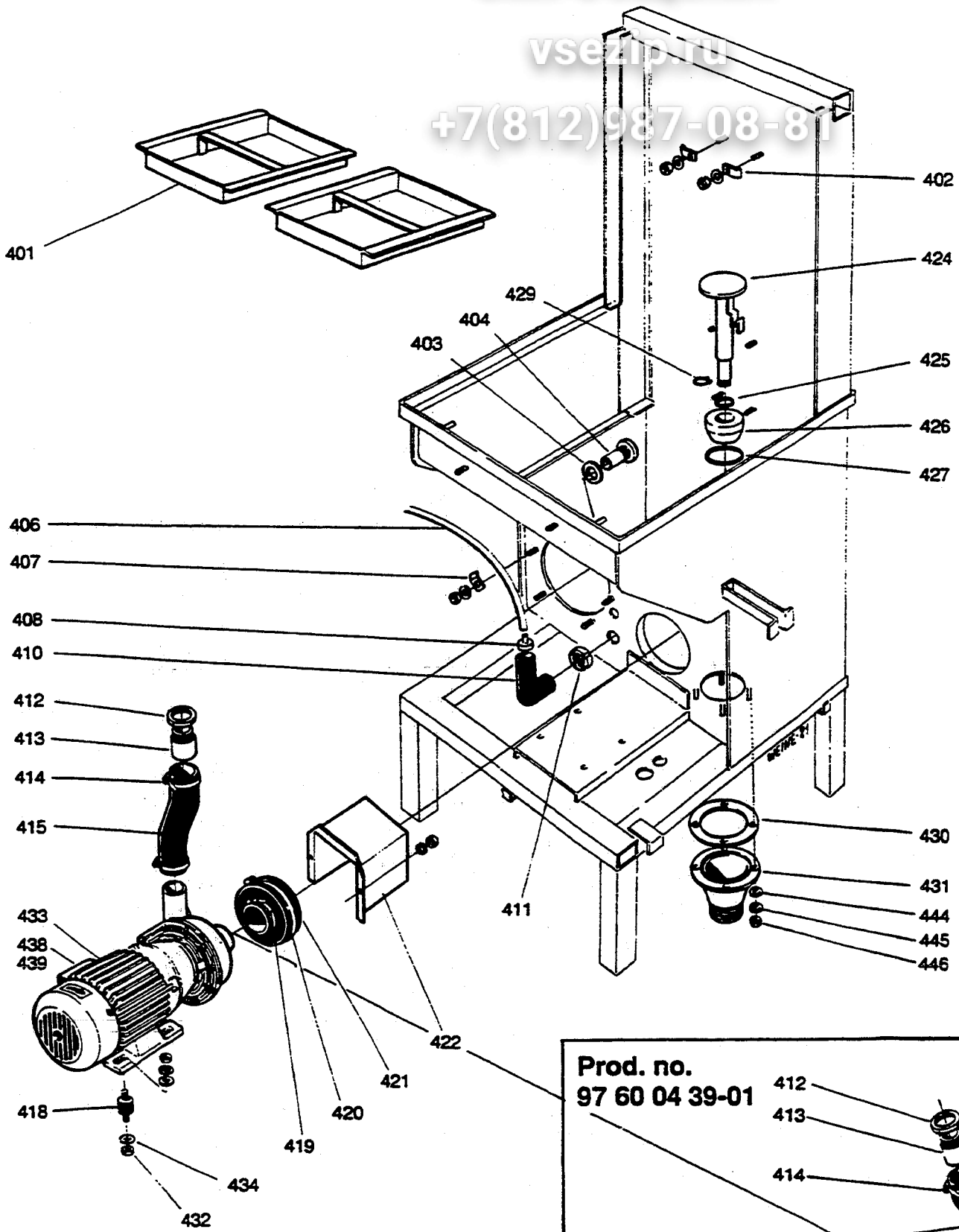

Зип Ощепит

vsezip.ru

+7(812)987-08-81

Prod. no. 97 60 04 31-02
Diskmedelsdoserare
Detergent injector

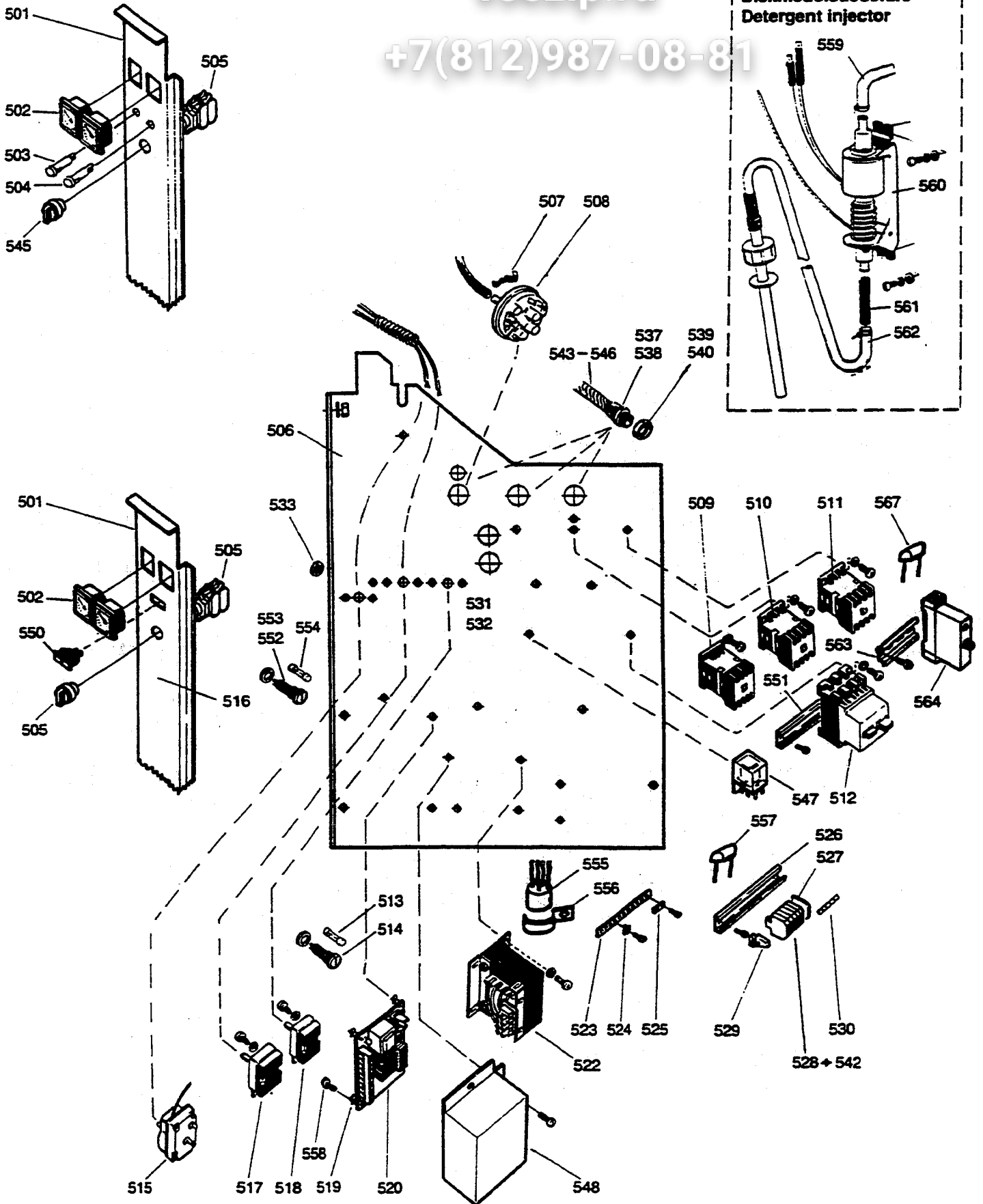

Prod. no.
97 60 04 39-01

Зип Общепит

vsezip.ru

+7(812)987-08-81

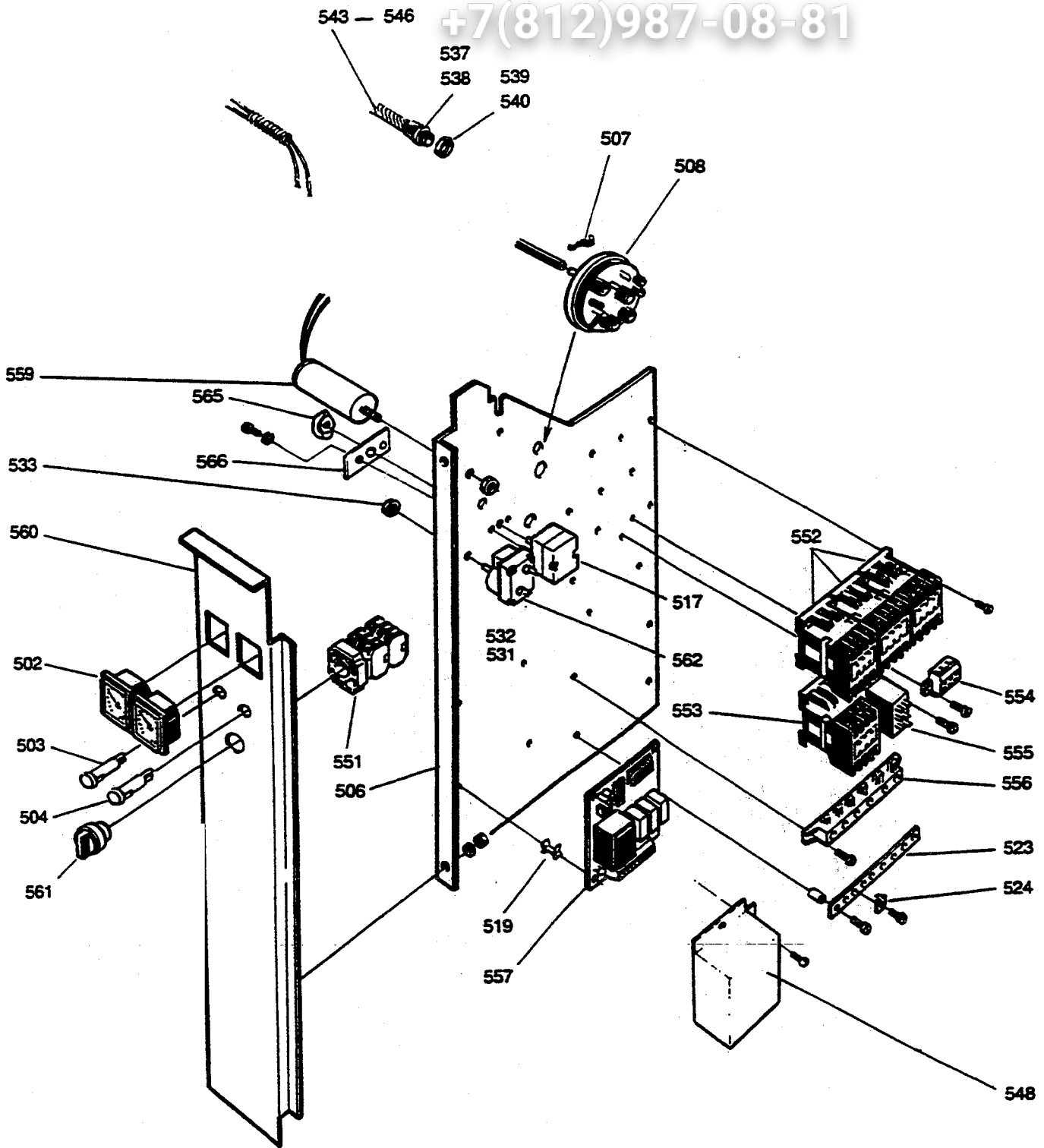

Зип Ощепит

vsezip.ru

+7(812)987-08-81

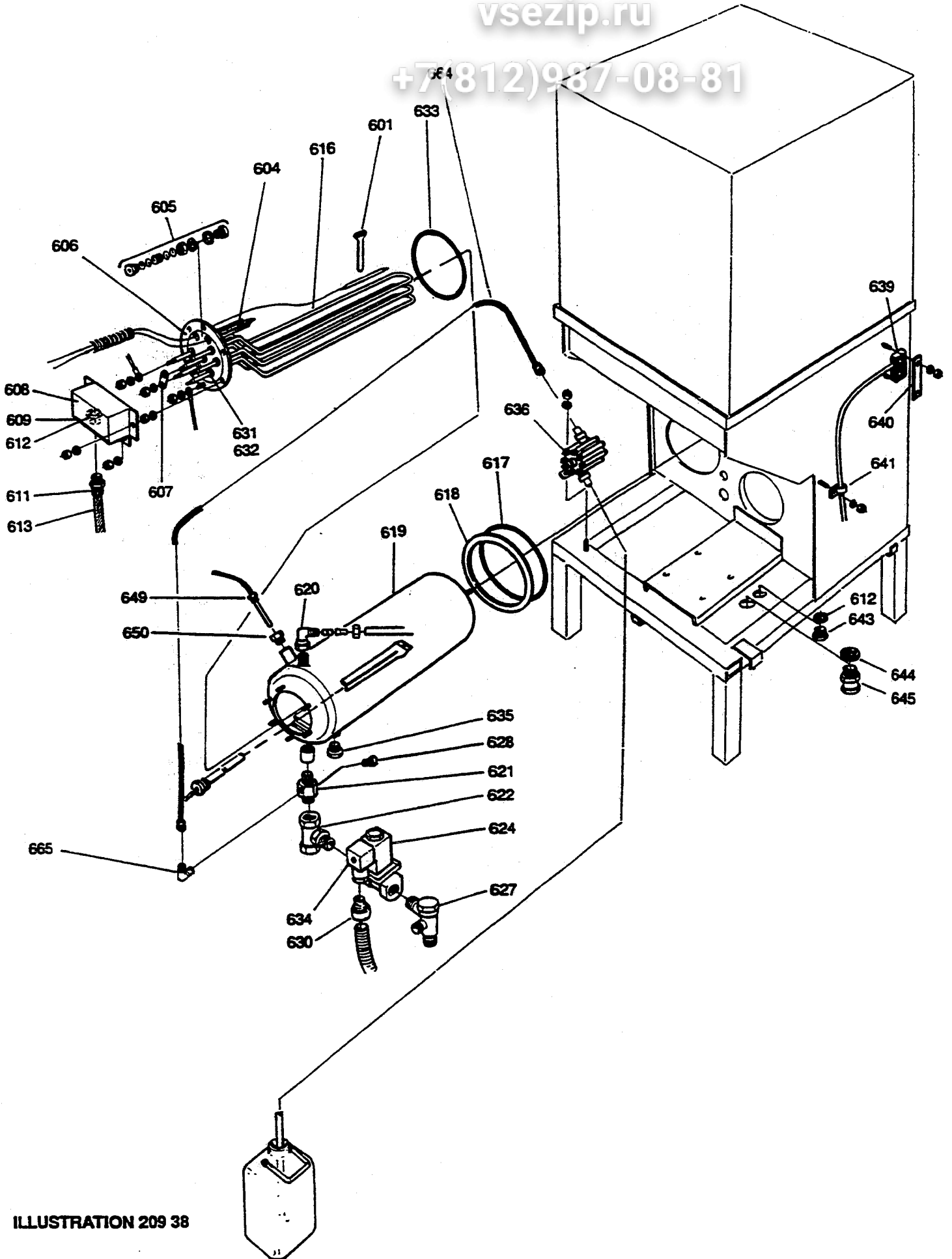

ILLUSTRATION 209 38

Prod. no.

- 975 88 01-02
- 975 88 21-02
- 97 60 03 25-02
- 97 60 03 40-01
- 97 60 03 41-01
- 97 60 04 22-02
- 97 60 04 31-02
- 97 60 04 39-01
- 97 60 05 01-02
- 97 60 05 02-02

Зип Общепит

vsezip.ru

+7(812)987-08-81

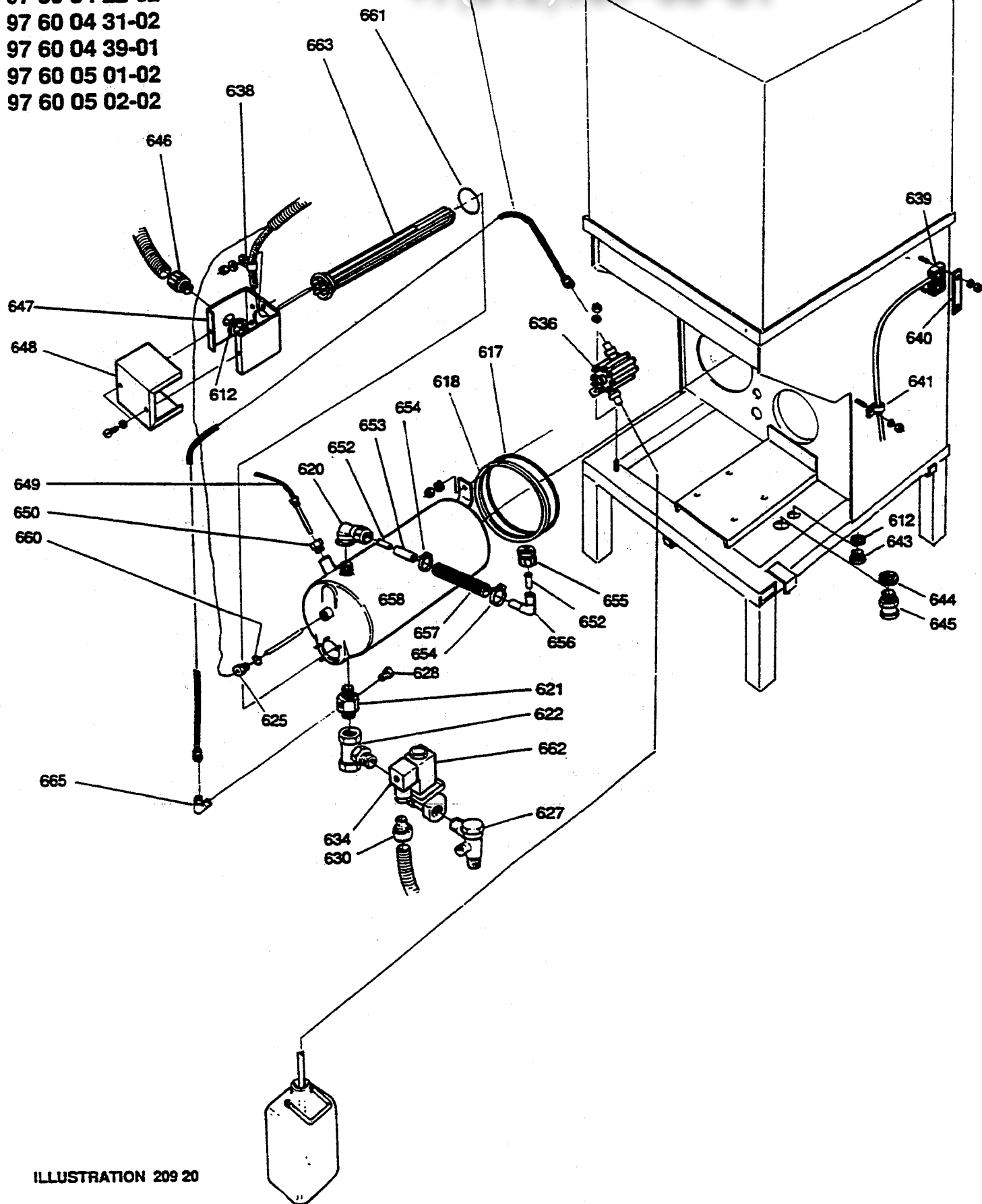

Зип Общепит

vsezip.ru

+7(812)987-08-81

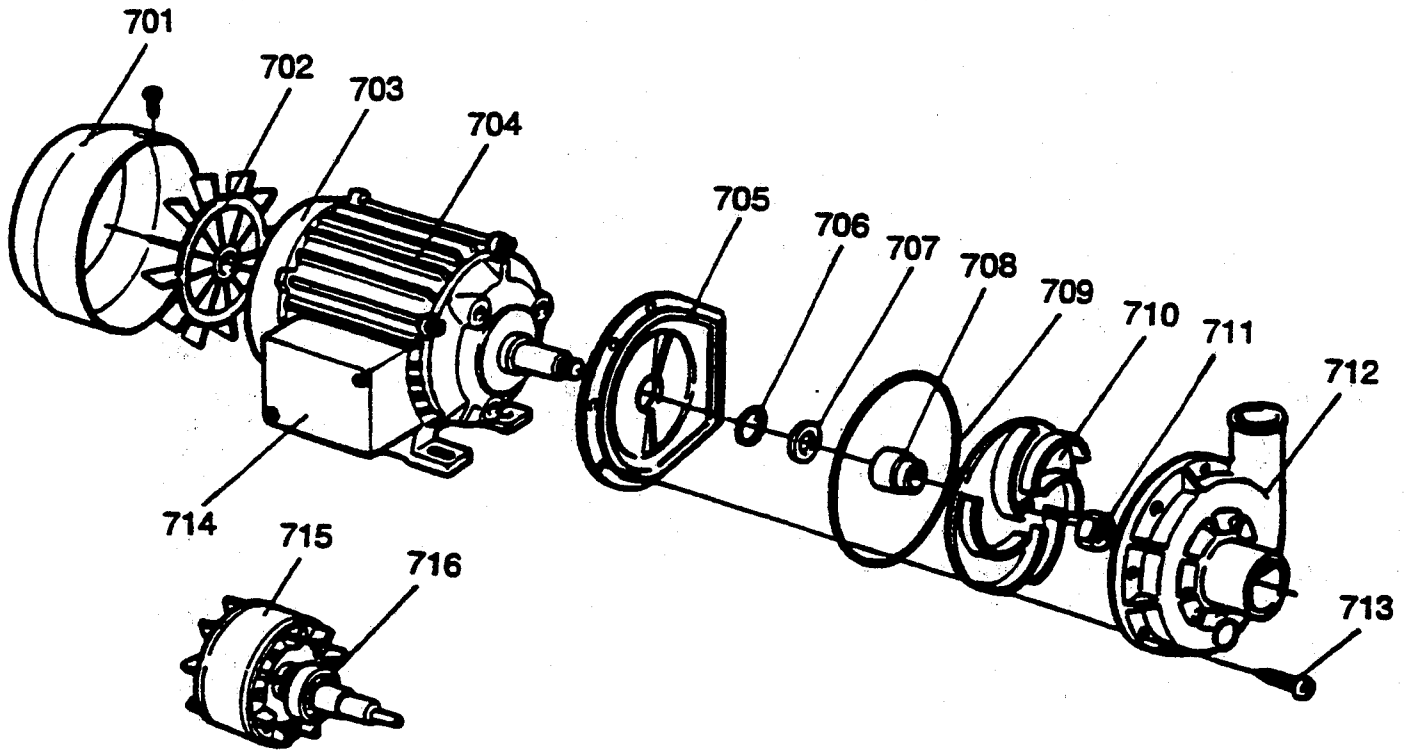

Prod. no.
97 60 05 02-02

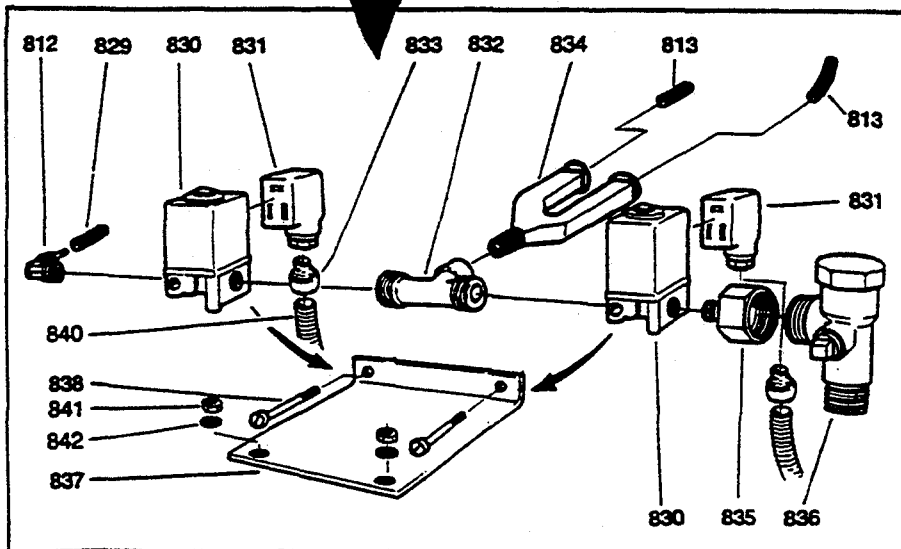
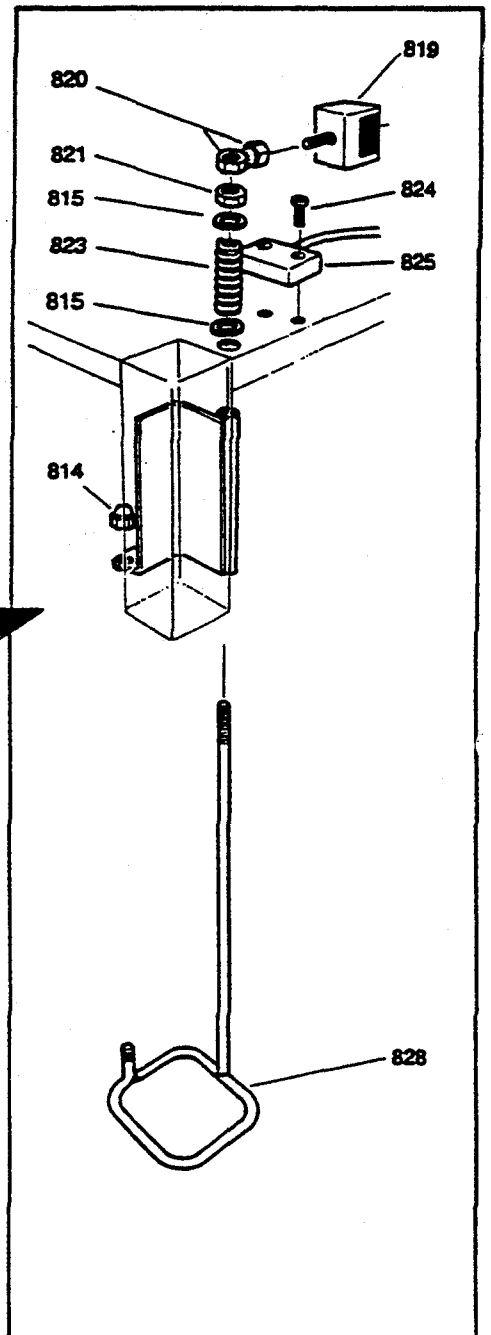
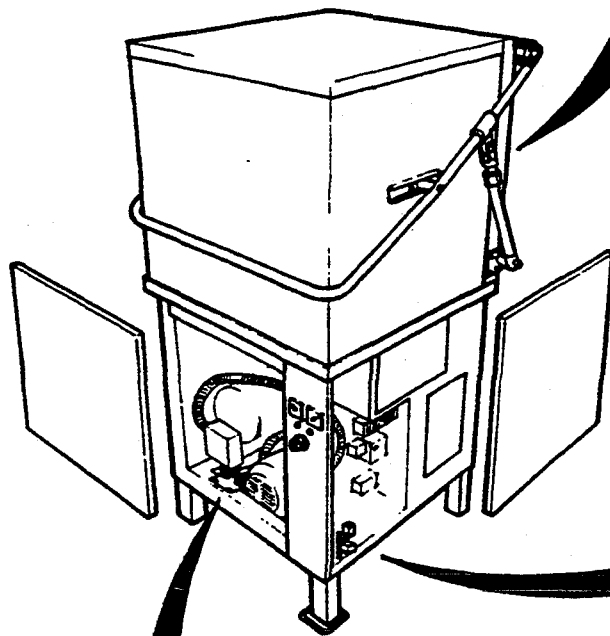
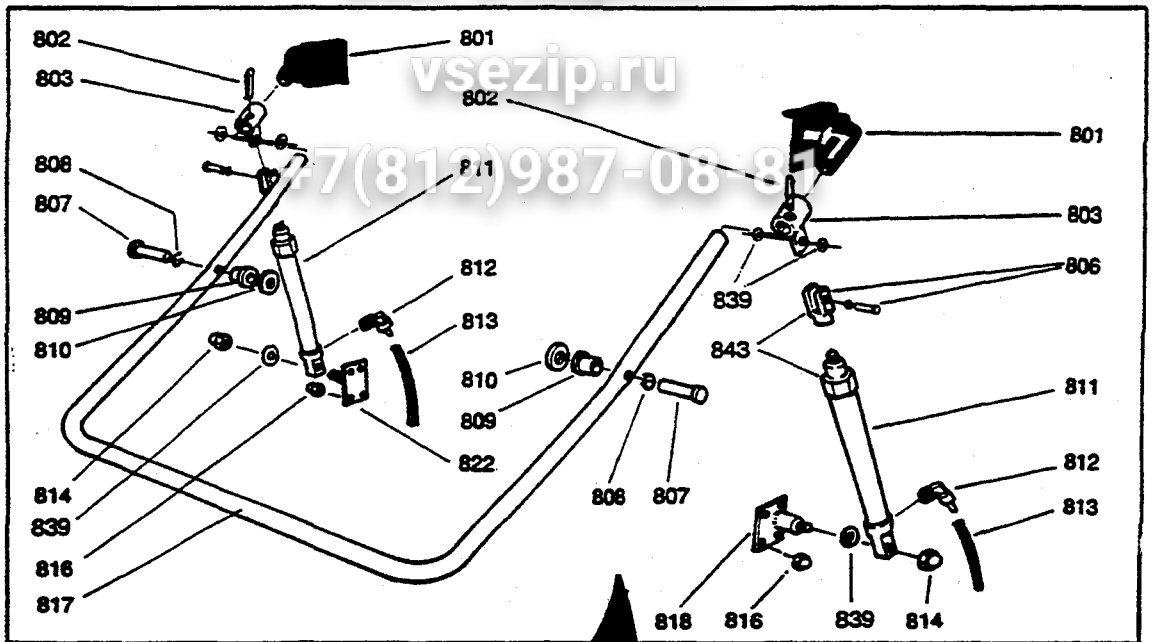

Prod. no.
975 88 21
975 88 22
975 88 23
97 60 04 xx
97 60 05 01

Зип Ощепит

vsezip.ru

+7(812)987-08-81

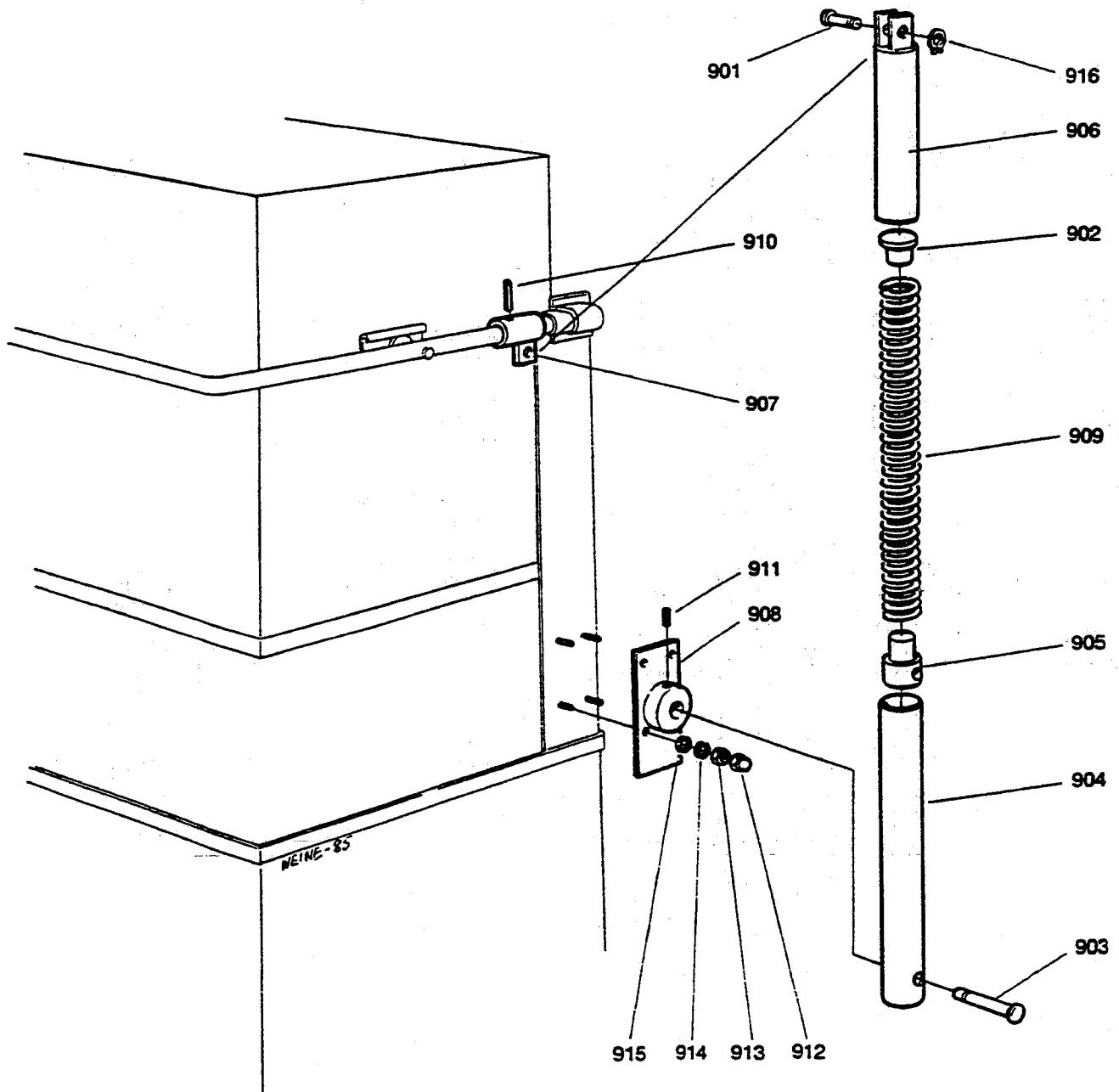

Prod. no.
97 60 05 02

Зип Общепит

vsezip.ru

+7(812)987-08-81

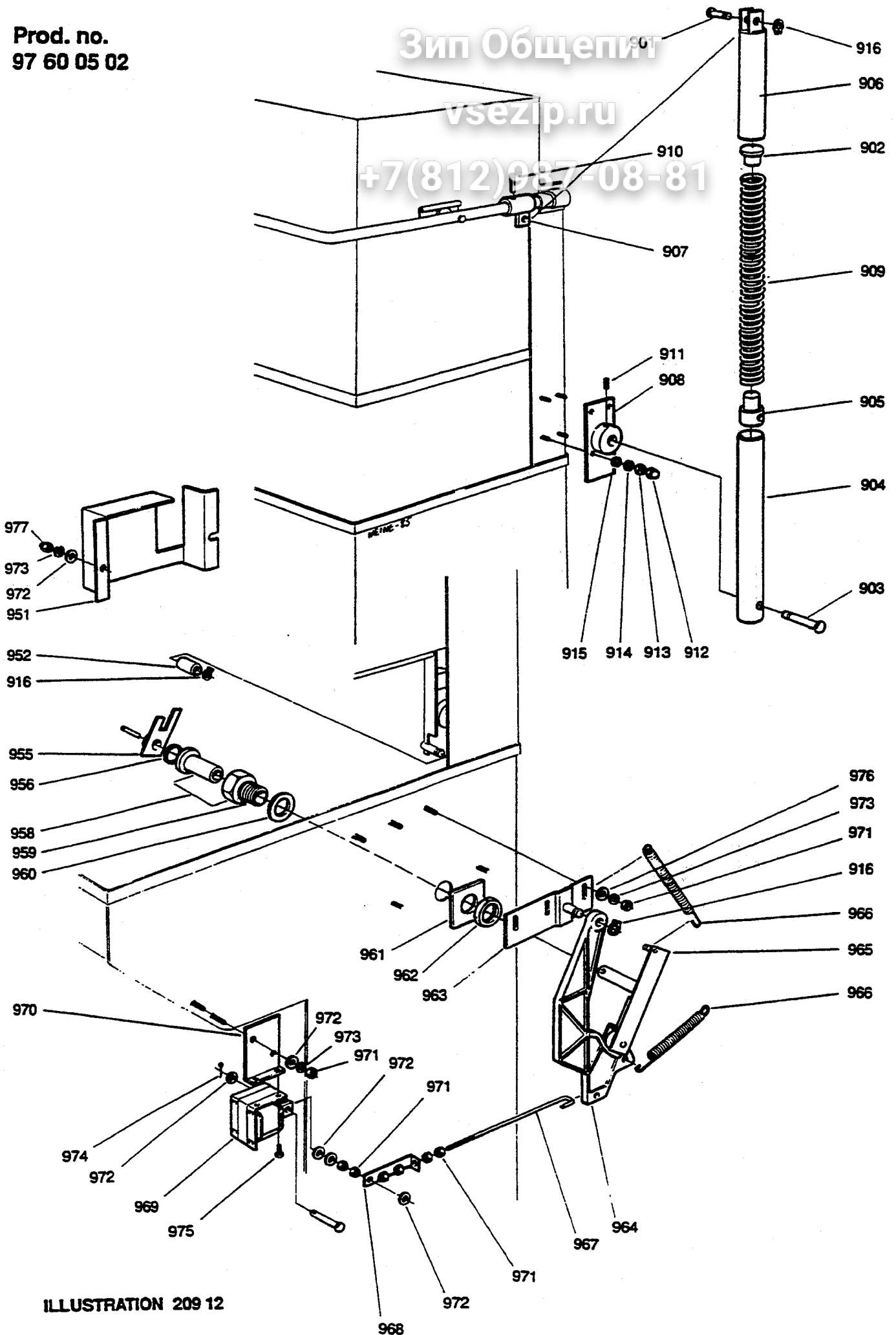

ILLUSTRATION 209 12