



MÁQUINA LAVAR F 400 - 6.0.095.0073

POTÊNCIA 2700 W
POWER

TENSÃO DE ALIMENTAÇÃO 230V/50Hz
POWER SUPPLY

CAPACIDADE DA CUBA 16 Lt / 2000W
TANK CAPACITY

CAPACIDADE DA CALDEIRA 3 Lt / 2000W
BOILER CAPACITY

ALTURA DE ENTRADA 290 mm
WORKING HEIGHT

PRODUTIVIDADE 30 cestos/h
PRODUCTIVITY

CONSUMO DE ÁGUA/CICLO 2 Lt
WATER CONSUMPTION

PESO LIQUIDO 31 kg
NET WEIGHT

PESO BRUTO 35,5 kg
GROSS WEIGHT

DIMENSÕES (LxPxH) 456x525x698 mm
DIMENSIONS (LxPxH)

DIMENSÕES DA EMBALAGEM (LxPxH) 535x575x830 mm
PACKAGE DIMENSIONS

DIMENSÕES DO CESTO (LxP) 400x400 mm
BASKET DIMENSIONS

MÁQUINA LAVAR F 400

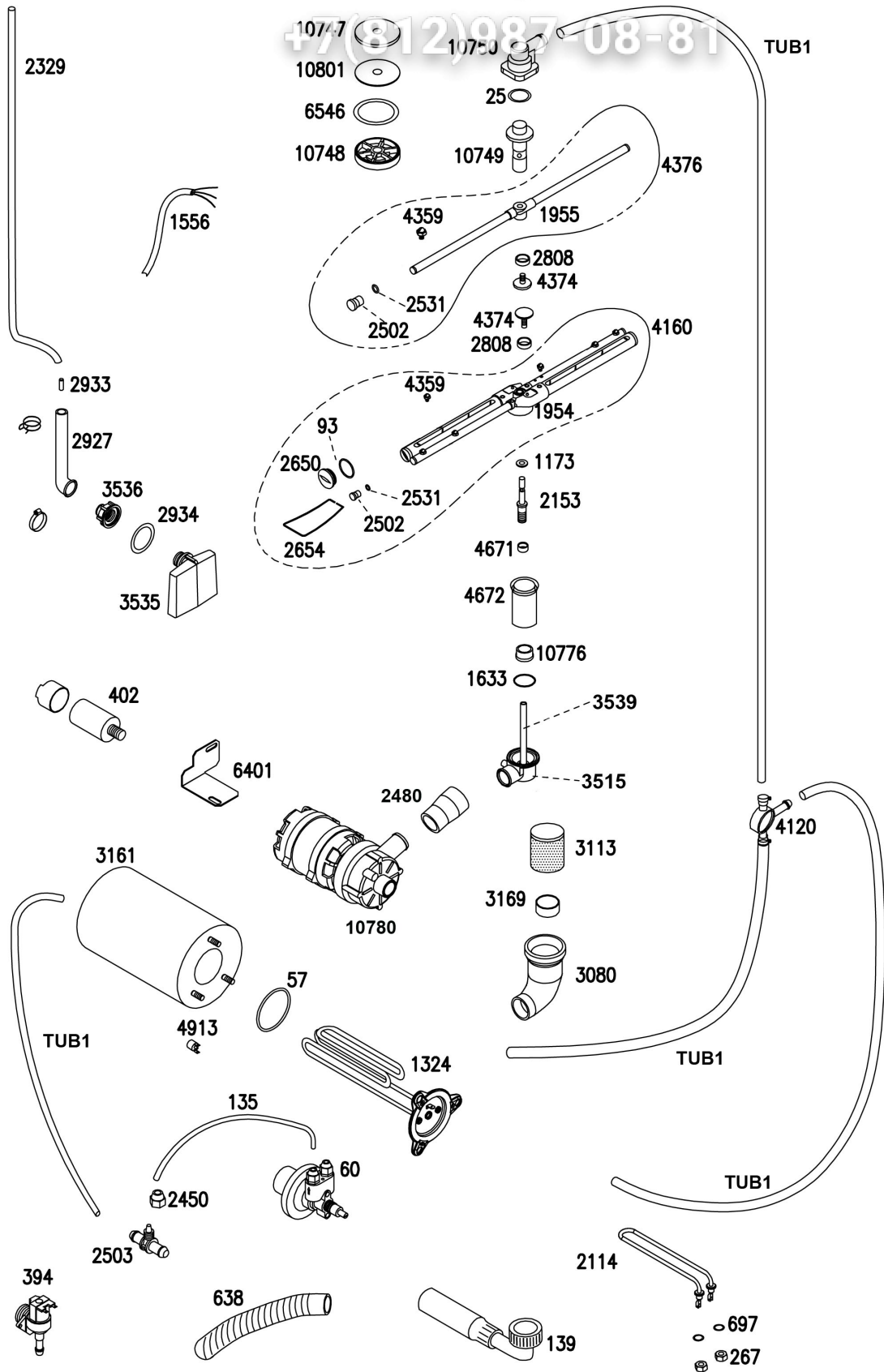

MÁQUINA LAVAR F 400 - 6.0.095.0073

MÁQUINA LAVAR F400

+7(812)987-08-81

LISTA DE COMPONENTES E ACESSÓRIOS

Spare parts list

ITEM Nº	CODIGO	DESIGNAÇÃO	DESIGNATION
25	5.0.097.0025	ORING 20,63X2,62	O'RING OR 128
32	5.0.097.0032	CURVA ESGOTO Ø35	DRAIN TUBE
57	5.0.097.0057	JUNTA RESISTENCIA CALDEIRA	BOILER HEATING ELEMENT GASKET
60	5.0.097.0060	BOMBA ABRILHANTADORA	BRIGHTENER DISPENSER
93	5.0.097.0093	ORING BRAÇO LAVAGEM	O'RING OR 121
108	5.0.097.0108	CURVA ESGOTO Ø22	DISCHARGE KNEE G3/4
109	5.0.097.0109	JUNTA 45X26X1,5 (CURVA ESGOTO Ø22)	RUBBER GASKET
110	5.0.097.0110	RACORD CURVA ESGOTO Ø22	DRAIN NUT G3/4
135	4.0.000.0850	TUBO TEFLON Ø6X1MM	TUBE 4X6MM
139	5.0.097.0139	TUBO ENTRADA AGUA	WATER INLET TUBE
187	5.0.097.0187	PORTA PIRES - 15	DISH HOLDER FOR BASKET
203	5.0.097.0203	PORCA CURVA ESGOTO Ø35	FASTENING NUT
204	5.0.097.0204	JUNTA 59X45X2,5 (CURVA ESGOTO Ø35)	RUBBER GASKET
267	5.0.097.0267	PORCA RESISTENCIA CUBA	HEATING ELEMENT NUT
359	5.0.097.0359	TERMOSTATO REGULAVEL 0-90°C	THERMOSTAT 0° TO 90° C1200
394	5.0.097.0394	ELECTROVALVULA SIMPLES 90° FINA	ELECTROVALVE 90°
402	5.0.097.0402	CONDENSADOR 6,3mf C1200	CONDENSATOR 6.3 MF C1200
612	5.0.097.0612	CERRA CABOS	CABLES FASTENER
638	5.0.097.0638	TUBO SAIDA AGUA F1221/F400	DRAIN TUBE
697	5.0.097.0697	ORING RESISTENCIA CUBA OR112	HEATING ELEMENT O'RING
1173	5.0.097.1173	ANILHA TEFLON 16X10X2	16X10X2MM TEFLON WASHER
1324	5.0.097.1324	RESISTENCIA CALDEIRA 2000W F1221/F400	BOILER HEATING ELEMENT 2000W
1556	4.0.125.0010	CABO H07RN-F 3G2,5	FEEDING CABLE 3X2.5X3500
1623	5.0.097.1623	TEMPORIZADOR 2 MIN.	TIMER
1633	5.0.097.1633	ORING CONCHA DISTRIBUIDORA	SHELL O'RING
1954	5.0.097.1954	DISTRIBUIDOR BRAÇO 4 VIAS	4RP DISTRIBUTOR
1955	5.0.097.1955	DISTRIBUIDOR BRAÇO 2 VIAS	2RP DISTRIBUTOR
2114	5.0.097.2114	RESISTENCIA CUBA 2000W F1221/F400/F430	TANK HEATING ELEMENT 2000W
2145	5.0.097.2145	CESTO COPOS 400X400	GLASS BASKET 400X400
2153	5.0.097.2153	VEIO HASTE INFERIOR	SHAFT FOR LOWER HAND
2194	5.0.097.2194	FECHO DA PORTA	DOOR LOCK ASSEMBLY
2329	5.0.097.2329	TUBO CAMARA DE AR/PRESSOSTATO	TUBE BETWEEN AIR CHAMBER AND PRESSURE SWITCH
2450	5.0.097.2450	PORCA RACORD T (CERRA TUBO)	TUBE FASTENER
2480		TUBO BOMBA/BRAÇO F400	CONNECTION RUBBER TUBE
2502	5.0.097.2502	TAMPAO BRAÇO ENXAGUAMENTO	COVER OF THE RINSE HAND
2503	5.0.097.2503	RACORD T TUBO Ø6-2X TUBO Ø12	RETENSION VALVE
2531	5.0.097.2531	ORING BRAÇO ENXAGUAMENTO	O'RING OR 106
2650	5.0.097.2650	TAMPAO BRAÇO LAVAGEM	CROSS PLASTIC COVER
2651	5.0.097.2651	MICRO INTERRUPTOR C-1200	MICRO SWITCH C-1200

MÁQUINA LAVAR F400

+7(812)987-08-81

LISTA DE COMPONENTES E ACESSÓRIOS

Spare parts list

ITEM Nº	CODIGO	DESIGNAÇÃO	DESIGNATION
2307	5.0.097.2307	COBERTURA INTERRUPTOR RECT.	SWITCH COVER
2329	5.0.097.2329	TUBO CAMARA DE AR/PRESSOSTATO	TUBE BETWEEN AIR CHAMBER AND PRESSURE SWITCH
2362	5.0.097.2362	PORCA RACORD ASPIRAÇÃO	RACORD FASTENING NUT
2373	5.0.097.2373	RACORD ASPIRAÇÃO	SUCTION RACORD
2374	5.0.097.2374	ORING RACORD ASPIRAÇÃO	O'RING 6275
2401	5.0.097.2401	CESTO PRATOS (18) 500X500	DISHES BASKET 500X500
2450	5.0.097.2450	PORCA RACORD T (CERRA TUBO)	TUBE FASTENER
2481	5.0.097.2481	RACORD TAMPAO	UPPER SHELL RACORD
2482	5.0.097.2482	TAMPAO	RACORD 90°
2502	5.0.097.2502	TAMPAO BRAÇO ENXAGUAMENTO	COVER OF THE RINSE HAND
2503	5.0.097.2503	RACORD T TUBO Ø6-2X TUBO Ø12	RETENSION VALVE
2531	5.0.097.2531	ORING BRAÇO ENXAGUAMENTO	O'RING OR 106
2650	5.0.097.2650	TAMPAO BRAÇO LAVAGEM	CROSS PLASTIC COVER
2654	5.0.097.2654	MOLA	SPRING FOR CROSS PLASTIC COVER
2655	5.0.097.2655	TUBO ASPIRAÇÃO F430/F532/F1040	SUCTION TUBE
2733	5.0.097.2733	SEPARADOR INOX	INOX SPACER
2763		ADAPTADOR DA FALANGE	BEARING ADAPTOR
2779		FILTRO ANTI-PARASITAS 0,47MF	ANTI-PARASITES FILTER 0,47MF
2789	5.0.097.2789	RACORD DISTRIBUIDOR 3VIAS	RACORD
2802	5.0.097.4731	VALVULA DVGW	DVGW VALVE BODY
2803	5.0.097.2803	PORCA VALVULA DVGW	FASTENING NUT FOR ANTI-FLOW VALVE
2808	5.0.097.2808	ANEL DISTRIBUIDOR	ZRP DISTRIBUTOR PTFE RING
2868	5.0.097.2868	ELECTROBOMBA 1HP 230V-50HZ F532	ELECTRIC PUMP 1HP
2900	5.0.097.2900	VEIO RACORD ASPIRAÇÃO	FILTER SHAFT
2919	5.0.097.2919	GUIA DO TIRANTE	NYLON GUIDE
2924	5.0.097.2924	PORCA CAMARA DE AR	NUT M20
2927	5.0.097.2927	TUBO ANTI-CONDENSAÇÃO	RACORD ANTI-CONDENSATION
2932	5.0.097.2932	CAMARA DE AR	AIR PLASTIC SHELL
2933	5.0.097.2933	TUBO CAMARA DE AR	SMALL TUBE FOR AIR CHAMBER
2934	5.0.097.2934	ORING CAMARA AR	O'RING 20,22X3,53
2962	5.0.097.2962	TUBO BOMBA/BRAÇO F430/F532	ELEVATION TUBE
2991		TUBO CILINDRO M12X1M/F	STAINLESS STEEL TUBE
2995	5.0.097.2995	CALDEIRA 5LT F430/F532	BOILER
3055		RAMPA LAVAGEM	WASHING AREA
3072		TUBO Ø30-37MM	TUBE Ø30-37MM
3086	5.0.097.3086	JUNTA VALVULA DVGW	RUBBER GASKET
3125	5.0.097.3125	FIXADOR PORTA F1221N	DOOR STOP PLATE
3134		TAMPA SUPERIOR	UPPER COVER
3135		TAMPA INFERIOR	LOWER TRIM PANEL
3136		PAINEL POSTERIOR	REAR PANEL

MÁQUINA LAVAR F400

+7(812)987-08-81

LISTA DE COMPONENTES E ACESSÓRIOS

Spare parts list

ITEM Nº	CODIGO	DESIGNAÇÃO	DESIGNATION
4671	5.0.097.4671	ANILHA ADAPTAÇÃO	SUPPORTING WASHER
4672	5.0.097.4672	CILINDRO Ø45X95	CYLINDER FOR ARM SUPPORT H95
4744	5.0.097.4744	TIRANTE PORTA	DOOR TENSIONER
4913	5.0.097.4913	TERMOSTATO 95°C CALDEIRA	THERMOSTAT 105°C
6143		JUNTA ADESIVA PORTA	SELF-ADHESIVE GASKET
6299	5.0.097.6299	TERMOSTATO 60°C CUBA	60°C THERMOSTAT
6401		SUPORTE BOMBA	PUMP SUPPORT
6546		ORING 158	158 O-RING
6642	5.0.097.0189	CESTO TALHERES	BASKET FOR SPOONS
6662	5.0.097.0134	PE REGULAVEL	ADJUSTABLE FOOT
10246	5.0.097.0246	DOBADIÇA PORTA DIR. F1221R	DOOR RIGHT HINGE
10247	5.0.097.0247	DOBADIÇA PORTA ESQ. F1221R	DOOR LEFT HINGE
10249		SUPORTE TERMINAIS	TERMINAL BLOCK SUPPORT
10293		JUNTA MICRO	MICROSWITCH GASKET
10294	5.0.097.0294	JUNTA DOBADIÇA	HINGE GASKET
10321		GUIA CESTO	R-L BASKET GUIDE
10338		PAINEL POSTERIOR	REAR PANEL
10339	5.0.097.0339	TAMPA COMANDO F400	UPPER COVER F 400
10342		TAMPA INFERIOR	LOWER TRIM PANEL
10368		PORTA F400	DOOR ASSEMBLY
10471		REFORÇO DIR. SUPORTE CESTO	RIGHT ENFORCE
10472		REFORÇO ESQ. SUPORTE CESTO	LEFT ENFORCE
10747		ANILHA	WASHER
10748		ANILHA RAIDA	WASHER
10750	5.0.097.0750	RACORD L M22X1F-Ø12	ANGLE RACORD
10776		CASQUILHO	SLEEVE
10780		ELECTROBOMBA 0,10HP F400	ELECTRIC PUMP 0,1HP
10801		ANILHA	WASHER
10808		TAMPAO	STOPPER
10929		SUPORTE TEMPORIZADOR	TIMER SUPPORT
35110	5.0.097.5110	PRESSOSTATO 55-30	PRESSURE SWITCH 55°30 C1200

MÁQUINA LAVAR F 400

R01

ESQUEMA ELECTRICO (TEMPORIZADOR MECÂNICO)

LEGENDA:

PT	GB	
D1	DESVIADOR QUENTE / FRIO	HOT / COLD SWITCH
DDF	DOSEADOR DE DETERGENTE	DETERGENT DISPENSER
DDR	DOSEADOR REGULAVEL DETERGENTE	DETERGENT DISPENSER ADJUSTABLE
DPS	PUSADOR PSC	PUSH BUTTON PSC
EV1	ELECTROVALVULA AGUA QUENTE	HOT SOLENOID VALVE
EV2	ELECTROVALVULA AGUA FRIA	COLD SOLENOID VALVE
H1	LAMPADA PIQOTO - MAQ. LIG.	APPLIANCE ON INDICATOR LIGHT
H2	LAMPADA PIQOTO - MAQ. PRONTA	APPLIANCE READY INDICATOR LIGHT
H3	LAMPADA PIQOTO - CICLO DE LAVAGEM	WASH CYCLE INDICATOR LIGHT
I6	INTERRUPTOR JERAI	ON / OFF SWITCH
ILC	INTERRUPTOR DE LAVAGEM CONTINUA	CONTINUOUS WASH SWITCH
IM	INTERRUPTOR DA MÁQUINA	APPLIANCE SWITCH
K1	CONTACTOR DA CALDEIRA	BOILER CONTACTOR
K2	CONTACTOR DA CUBA	TANK CONTACTOR
K3	CONTACTOR DA BOMBA	PUMP CONTACTOR
K5	CONTACTOR DE SEGURANÇA	SAFETY CONTACTOR
MM/PT	MEQUINTEIRO DE PORTA	DOOR SWITCH
MA	CLIXA DE LIGACAO	MAINS CONNECTION TERMINAL BOARD
MT	MOTOR PROGRAMADOR	WASHER TIMER MOTOR
MT(L)	CONTACTOS PROGRAMADOR	WASHER TIMER SWITCH
PLV	BOMBA DE LAVAGEM	WASH PUMP
PR	PRESSOSTATO	PRESSURE SWITCH
PSC	BOMBA DE ESPRITO	DRAIN PUMP
PSP	BOMBA ADICIONAL	BOOSTER PUMP
RB	RESISTENCIA DA CALDEIRA	BOILER HEATING ELEMENT
RFI	FILTRO ANTI INCHIZAS	SUPPRESSOR
RV	RESISTENCIA TA LAVAGEM	TANK HEATING ELEMENT
START	BOTAO INICIO LAVAGEM	START WASH BUTTON
T1	TERMOSTATO DA CALDEIRA	BOILER THERMOSTAT
T2	TERMOSTATO DA CUBA	TANK THERMOSTAT
T51	TERMOSTATO SEGURANCA DA CALDEIRA	BOILER SAFETY THERMOSTAT
T52	TERMOSTATO SEGURANCA DA CUBA	TANK SAFETY THERMOSTAT

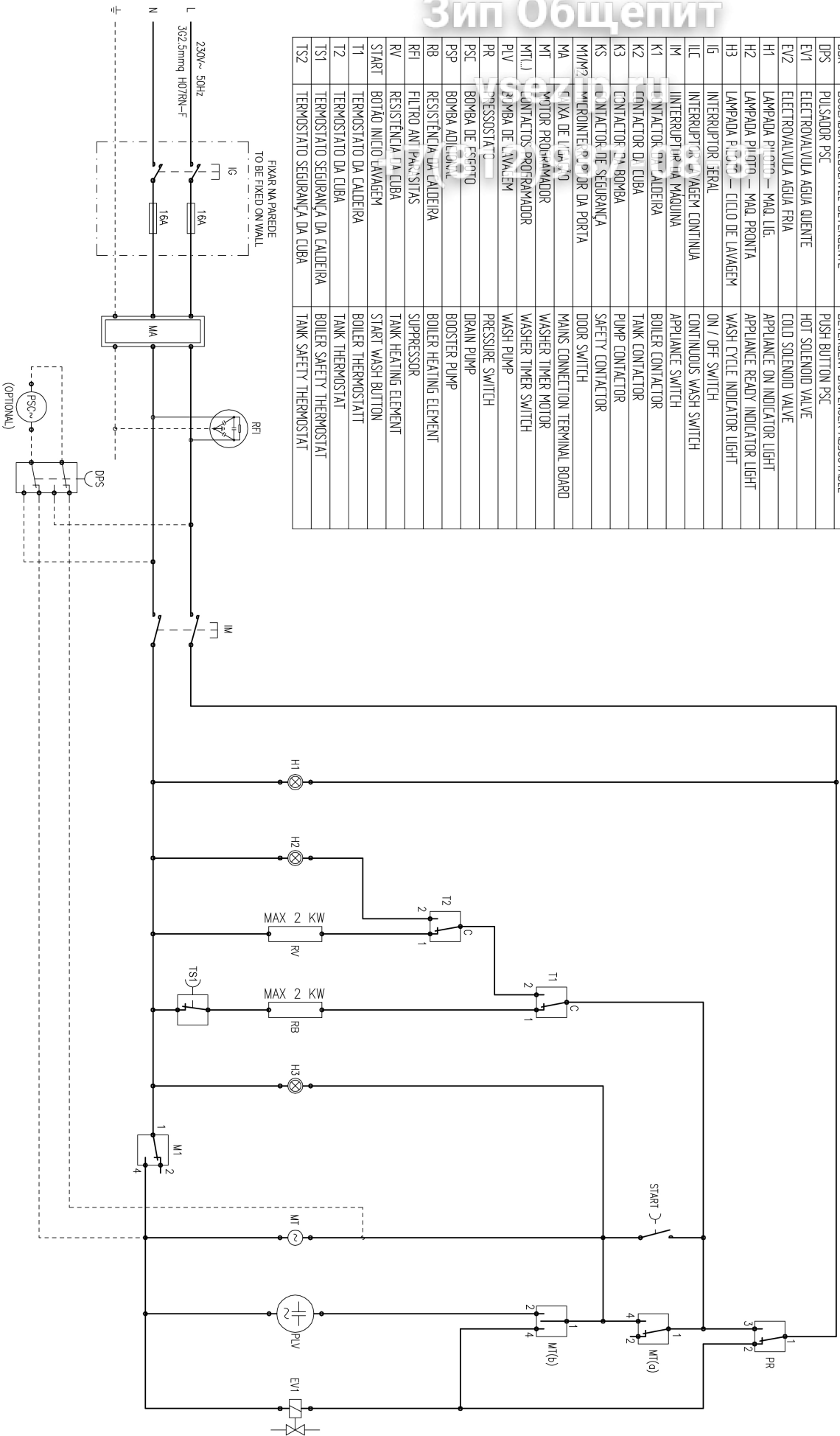

MÁQUINA LAVAR F 400

ESQUEMA ELÉTRICO (TEMPORIZADOR ELECTRÓNICO)

R01

PT	GB
AZUL	BLUE
BRANCO	WHITE
CASTANHO	BROWN
CINZA	GREY
LARANJA	ORANGE
PRETO	BLACK
ROSA	PINK
VERDE	GREEN
VERMELHO	RED
VIOLETA	VIOLET

Зип Общепит

vsezip.ru

+7(812)987-08-81

