

Зип Общепит

vsezip.ru

DESPIECE TECNICO

+7(812)987-08-81

Cocedor de pasta
Pasta cooker
Cuiseur à pâtes
Nudelkocher
Cuocipasta
Cozedor de massa

GAMA 900

Modelos:

CPG9-05

CPE9-05

CPG9-05 S

CPE9-05 S

Marzo 2009 March

Revisado Marzo 2014 March Revised

FAGOR 

F A G O R I N D U S T R I A L

Зип Общежит
 vsezip.ru
 +7(812)987-08-81

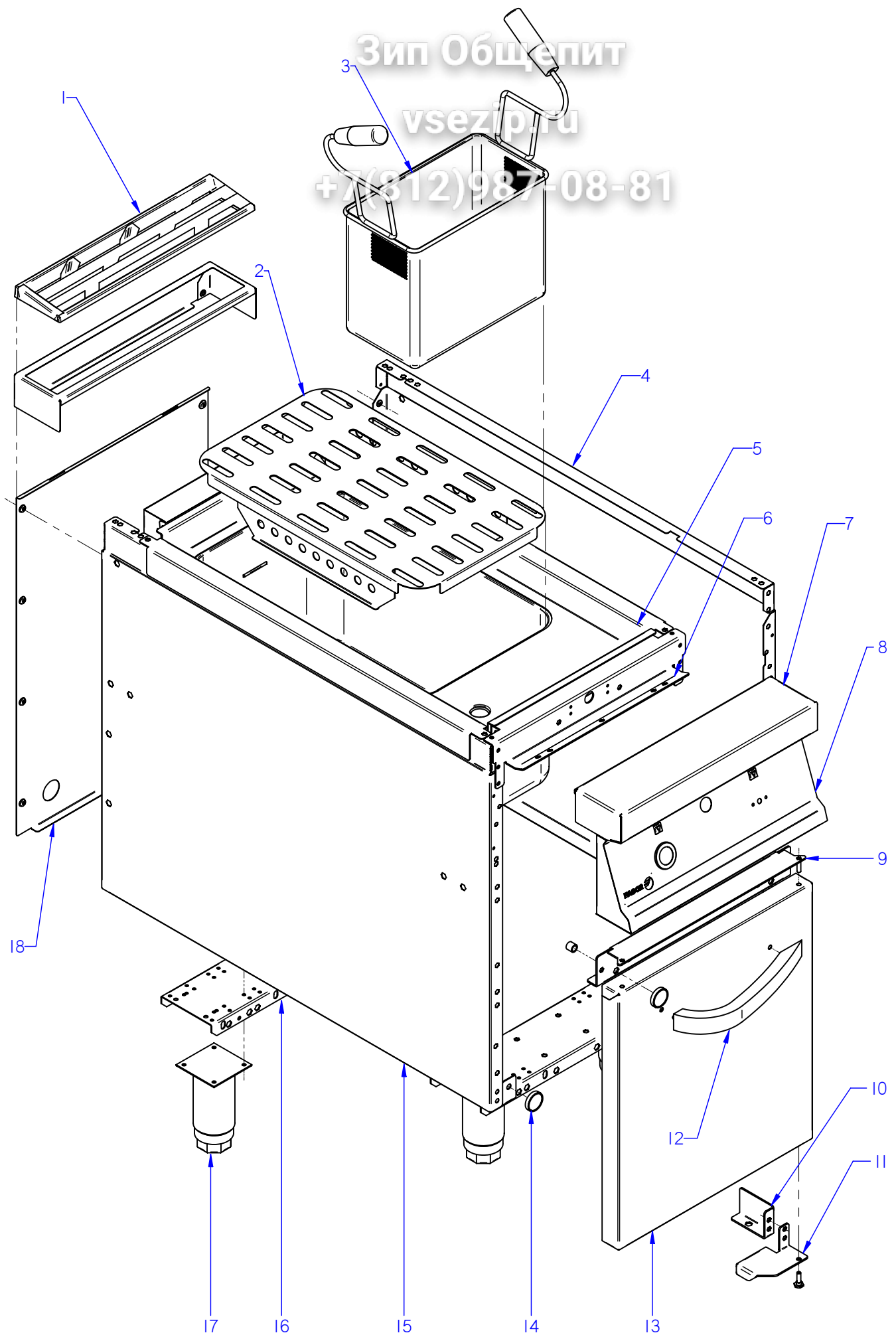

ITEM MARCADO EN COLOR = REPUESTO RECOMENDADO
 COLOURED ITEM = RECOMMENDED SPARE PART

N plano	Firma	Fecha	Aparato	MUEBLE	Lamina	Fagor Industrial S.Coop. FAGOR
C-2200	<i>(Signature)</i>	2009-03		COCEDOR DE PASTA	1	Oñate

MOD.		COCEDOR DE PASTA		ZONA	MUEBLE				
ITEM	CODIGO	DENOMINACION	TEXTO	CPG9-05 NC	CPG9-05	CPG9-05 S NC	CPG9-05 S	CPG9-05 NC	
1	R205425000	EMBELLECEDOR ESMALTE	REAR TRIM.	1	1	1	1	1	
S/Nº	R205438000	SOPORTE EMBELLECEDOR 1/2M	TRIM SUPPORT	1	1	1	1	1	
	Q419005000	REMACHE 4X8 ALMG3 / ALUMINIO	RIVET 4X8 ALMG3 / ALUMINIUM	12	12	12	12	12	
2	H066108000	SOPORTE CESTILLOS COMPLETO	COMPLETE BASKET SUPPORT	1	1	1	1	1	
3	H506500000	CESTILLO CUECEPASTA GN 1/3	BASKET	—	3	—	3	—	
4	X162814000	PANEL LATERAL DERECHO	RIGHT SIDE PANEL	1	1	—	—	1	
4	S142806000	PANEL LATERAL DERECHO SUSP.	SUSP. RIGHT SIDE PANEL	—	—	1	1	—	
4	S222808000	PANEL LATERAL DERECHO	RIGHT SIDE PANEL	—	—	1	1	—	
	Q221345000	REMACHE EXAGONAL M10	HEXAGONAL RIVET M10	2	2	2	2	2	
	Q221343000	REMACHE EXAGONAL M6	HEXAGONAL RIVET M6	11	11	11	11	11	
	Q221342000	REMACHE EXAGONAL M5	HEXAGONAL RIVET M5	6	6	6	6	6	
5	H406101000	CUBA COMPLETA CPG-905	COMPLETE TUB CPG-905	1	1	—	—	—	
5	H516105000	CUBA COMPLETA CPG-905 S	COMPLETE TUB CPG-905 S	—	—	1	1	—	
5	H066112000	CUBA COMPLETA CPE9-05	COMPLETE TUB CPE9-05	—	—	—	—	1	
5	H066113000	CUBA COMPLETA CPE9-05 S	COMPLETE TUB CPE9-05 S	—	—	—	—	—	
	Q162030000	TUERCA EXAGONAL M5	HEXAGONAL NUT M5	6	6	6	6	3	
6	X162680000	ESCUAD INTER ANTER MESA 1/2M	BENCH FRONT INT. BRACKET 1/2	1	1	1	1	1	
6	X162690000	ESCUAD INTER ANTER MESA 1/2M	BENCH FRONT INT. BRACKET 1/2	1	1	1	1	1	
	Q221342000	REMACHE EXAGONAL M5	HEXAGONAL RIVET M5	4	4	4	4	4	
	Q012032000	TORNILLO EXAGONAL M5X15	HEXAGONAL BOLT M5X15	6	6	6	6	6	
7	R045416000	ANTERIOR MESA 1/2M	FRONT BENCH 1/2M	1	1	—	—	1	
	Q152004000	TORNIL. APLASTADO M5X13 A 304	FLAT HEADED SCREW M5x13 A 304	2	2	—	—	2	
	Q302022000	ARANDELA 16X6X1.2 A.304	WASHER 16X6X1.2 A.304	2	2	—	—	2	
8	H502806000	PORTAMANDOS COMPL. CPG9-05	CONTROL HOLDER CPG9-05	1	1	1	1	—	
8	12041162	PORTAMANDOS COMPL. CPG9-00	CONTROL HOLDER CPG9-00	1	1	1	1	—	
8	H062805000	PORTAMANDOS COMPL. CPE-905	CONTROL HOLDER CPE9-05	—	—	—	—	1	
8	H042805000	PORTAMANDOS COMPL. CPE	CONTROL HOLDER CPE	—	—	—	—	1	
	Q152004000	TORNIL. APLASTADO M5X13 A 304	FLAT HEADED SCREW M5x13 A 304	4	4	4	4	4	
	U022836000	ESCUDO FAGOR	FAGOR EMBLEM	1	1	1	1	1	
	Q221023000	CLIP SUJECIÓN RÁPIDA Ø5	RAPID CONNECT CLIP Ø5	2	2	2	2	2	

MOD.		COCEDOR DE PASTA		ZONA		MUEBLE				
ITEM	CODIGO	DENOMINACION	TEXTO	CPG9-05 NC	CPG9-05	CPG9-05 S NC	CPG9-05 S	CPG9-05 NC	CPG9-05 S	
9	X162669000	LISTON BISAGRA SUPERIOR DCHA.	UPPER RIGHT HINGE STRIP	1	1	1	1	1	1	
	Q221342000	REMACHE EXAGONAL M5	HEXAGONAL RIVET M5	8	8	8	8	8	8	
	Q152004000	TORN. APLASTADO M5x13 A304	FLAT HEADED SCREW M5x13	4	4	4	4	4	4	
10	U020526000	ESCUADRA REFUERZO BISAGRA	HINGE REINFORCEMENT BRACK	1	1	-	-	-	1	
11	U020511000	BISAGRA DERECHA INFERIOR	LOWER RIGHT HINGE	1	1	-	-	-	1	
11	X190504000	BISAGRA DERECHA INFERIOR SUS.	LOWER RIGHT HINGE SUS.	-	-	1	1	-	-	
	Q012042000	TORNILLO EXAGONAL M6X15	HEXAGONAL BOLT M6X15	2	2	-	-	-	2	
	Q302022000	ARANDELA 16X6X1.2 A.304	WASHER 16X6X1.2 A.304	2	2	-	-	-	2	
	X960504000	TORNILLO DE GIRO M8	ROTATION BOLT M8	1	1	1	1	1	1	
	Q232040000	ARANDELA A6	WASHER A6	2	2	1	1	1	2	
12	U020507000	ASA PUERTA	FULL CUPBOARD HANDLE	1	1	1	1	1	1	
	Q162040000	TUERCA EXAGONAL M6	HEXAGONAL NUT M6	2	2	2	2	2	2	
	Q302022000	ARANDELA 16X6X1.2 A.304	WASHER 16X6X1.2 A.304	2	2	2	2	2	2	
13	U020502000	PUERTA LATERAL G900	SIDE DOOR G900	1	1	-	-	-	1	
13	U020513000	PUERTA LATERAL SUSPENDIDA	SUSP. SIDE DOOR	-	-	1	1	-	-	
13	U020536000	PUERTA LATERAL G 900(2008)	SIDE DOOR G 900(2008)	1	1	1	1	1	1	
S/Nº	U020503000	CONTRAPUERTA LATERAL G900	SIDE DOOR REVERSE G900	1	1	-	-	-	1	
S/Nº	U020537000	CONTRAPUERTA LATERAL G900	SIDE DOOR REVERSE G900	1	1	-	-	-	1	
S/Nº	U020514000	CONTRAPUERTA LATERAL SUSP.	SUSP. SIDE DOOR REVERSE	-	-	1	1	-	-	
S/Nº	U020537000	CONTRAPUERTA LATERAL G900	SIDE DOOR REVERSE G900	-	-	1	1	-	-	
	Q419005000	REMACHE 4X8 ALMG3 / ALUMINIO	RIVET 4X8 ALMG3 / ALUMINIUM	4	4	4	4	4	4	
14	X960501000	IMAN	MAGNET	2	2	2	2	2	2	
S/Nº	X960502000	FIJACION IMAN	MAGNET ATTACHMENT	2	2	2	2	2	2	
	Q012021000	TORNILLO EXAGONAL M4X10	HEXAGONAL BOLT M4X10	2	2	2	2	2	2	
	Q232020000	ARANDELA A4	WASHER A4	2	2	2	2	2	2	
15	X162813000	PANEL LATERAL IZQUIERDO	LEFT SIDE PANEL	1	1	-	-	-	1	
15	S142805000	PANEL LATERAL IZQUIERDO SUS.	SUSP. LEFT SIDE PANEL	-	-	1	1	-	-	
15	S222807000	PANEL LATERAL IZQUIERDO	LEFT SIDE PANEL	-	-	1	1	-	-	
	Q221345000	REMACHE EXAGONAL M10	HEXAGONAL RIVET M10	2	2	2	2	2	2	
	Q221343000	REMACHE EXAGONAL M6	HEXAGONAL RIVET M6	11	11	1	1	1	1	
	Q221342000	REMACHE EXAGONAL M5	HEXAGONAL RIVET M5	6	6	6	6	6	6	

Зип Общепит

vsezip.ru

+7(812)987-08-81

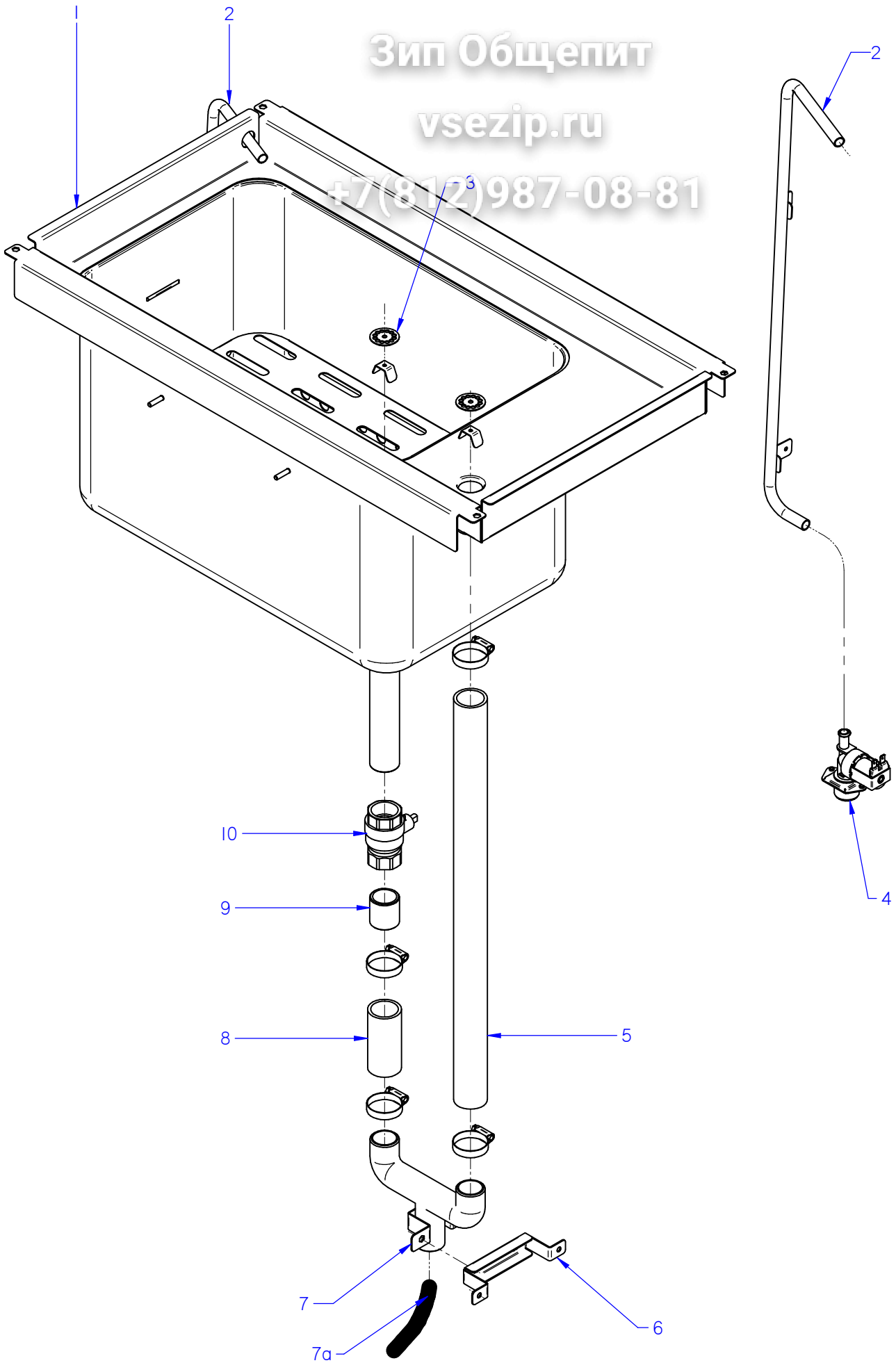

ITEM MARCADO EN COLOR = REPUESTO RECOMENDADO
COLOURED ITEM = RECOMMENDED SPARE PART

N plano	Firma	Fecha	Aparato	TOMA DE AGUA Y DESAGÜE	Lamina	Fagor Industrial S.Coop. FAGOR
C-2201	<i>(Signature)</i>	2009-03	COCEDOR DE PASTA		2	Oñate

MOD.		COCEDOR DE PASTA		ZONA	TOMA DE AGUA Y DESAGÜE			
ITEM	CODIGO	DENOMINACION	TEXTO	CPG9-05	CPG9-05 S	CPE9-05	CPE9-05 S	
1	H506122000	CUBA COMPLETA CPG-905	COMPLETE TUB CPG-905	1	-	-	-	
1	H046101000	CUBA COMPLETA AD	COMPLETE TUB AD	1	-	-	-	
1	H516105000	CUBA COMPLETA CPG-905 S	COMPLETE TUB CPG-905 S	-	1	-	-	
1	H046103000	CUBA COMPLETA SUSP.AD	COMPLETE TUB AD S	-	1	-	-	
1	H066112000	CUBA COMPLETA CPE9-05	COMPLETE TUB CPE9-05	-	-	1	-	
1	H046104000	CUBA COMPLETA CPE AD	COMPLETE TUB CPE AD	-	-	1	-	
1	H066113000	CUBA COMPLETA CPE9-05 S	COMPLETE TUB CPE9-05 S	-	-	-	1	
1	H046106000	CUBA COMPLETA ELEC SUS AD	COMPLETE TUB ELEC SUS AD	-	-	-	1	
2	H505051000	TUBO LLENADO CP	FILLER PIPE CP	1	-	1	-	
2	H505054000	TUBO LLENADO CP SUSP.	SUSP. FILLER PIPE CP	-	1	-	1	
2	H505058000	CONDUCCION ENTRADA DE AGUA	RUNNING WATER INLET	1	1	1	1	
	Q419005000	REMACHE 4X8 ALMG3 / ALUMINIO	RIVET 4X8 ALMG3 / ALUMINIUM	2	2	2	2	
S/Nº	3676900000	TUBO GOMA NEGRA Ø 17*10	BLACK RUBBER PIPE 17*10	1	1	1	1	
	Q881302000	ABRAZADERA 8-14L	CLAMP 8-14L	2	2	2	2	
3	H506111000	FILTRO DESAGÜE	DRAINAGE FILTER	2	2	2	2	
S/Nº	H506112000	PATILLA FILTRO DESAGÜE	DRAINAGE FILTER PIN	2	2	2	2	
	Q412000000	REMACHE TUBULAR Ø 4 x 8	TUBULAR RIVET Ø 4 x 8	2	2	2	2	
4	Z701135000	E.V.SIMP.220V COD.255.208	E.V.SIMP.220V COD.255.208	1	1	1	1	
	Q032021000	TORNILLO ALOMADO M4X10	CURVED SCREW M4X10	2	2	2	2	
5	3714100000	TUBO SILICONA Ø 38*31 550	SILICON PIPE Ø 38*31 550	1	1	1	1	
	Q881305000	ABRAZADERA Ø25-40	CLAMP Ø25-40	2	2	2	2	
6	H522628000	CALZO DESAGÜE G900	DRAINAGE WEDGE G900	1	-	1	-	
S/Nº	H515008000	ESCUAD. SUP.TUBO DESAG. SUS.	DRAINAGE PIPE UPPER BRACKE	-	1	-	1	
	Q221342000	REMACHE EXAGONAL M5	HEXAGONAL RIVET M5	2	-	-	-	
	Q012042000	TORNILLO EXAGONAL M6X15	HEXAGONAL BOLT M6X15	2	2	2	2	
	Q302022000	ARANDELA 16X6X1.2 A.304	WASHER 16X6X1.2 A.304	-	4	4	4	

Зип Общепит

vsezip.ru

+7(812)987-08-81

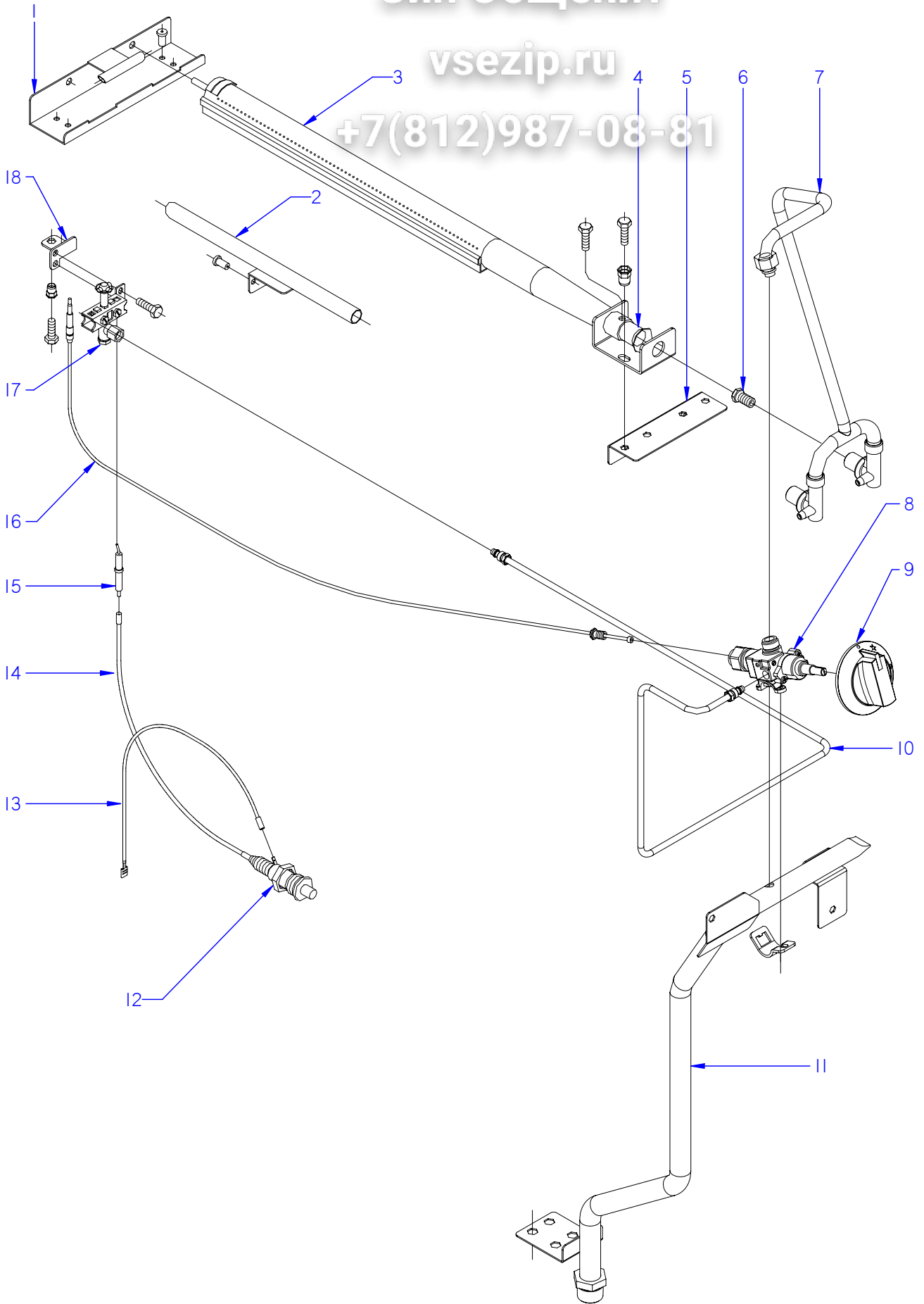

ITEM MARCADO EN COLOR = REPUESTO RECOMENDADO
COLOURED ITEM = RECOMMENDED SPARE PART

N plano	Firma	Fecha	Aparato	CONJUNTO FUNCIONAL DE GAS	Lamina	Fagor Industrial S.Coop. FAGOR
C-2202	<i>[Signature]</i>	2009-03	COCEDOR DE PASTA		3	Oñate

Зип Общепит

MOD.		COCEDOR DE PASTA		vsezip.ru		CONJUNTO FUNCIONAL DE GAS			
ITEM	CODIGO	DENOMINACION	TEXTO	CPG9-05	CPG9-05 S				
1	H505705000	SOPORTE ENCENDIDO QUEMAD.	COMPLETE BURNER IGNITION	1	1				
	Q419005000	REMACHE 4x8 ALMG3 / ALUMINIO	RIVET 4X8 ALMG3 / ALUMINIUM	2	2				
	Q302022000	ARANDELA 16X6X1.2 A.304	WASHER 16X6X1.2 A.304	2	2				
2	H505708000	TUBO ENCENDIDO PILOTO COMP.	COMP PILOT IGNITION PIPE	1	1				
	Q081365000	TOR. ALOMADO 4,8X19 H.ZINCADO	CURVED SCREW 4.8X19 H.ZINC	2	2				
3	H505700000	QUEMADOR COMPLETO CP	COMPLETE BURNER CP	2	2				
4	U325707000	REGULADOR DE AIRE (QUEMAD.)	AIR CONTROL (BURNER)	2	2				
	Q012032000	TORNILLO EXAGON. M5X15	HEXAGONAL BOLT. M5X15	2	2				
5	H505737000	ESCUAD. AMARRE QUEMADORES	BURNER FASTENING BRACKET	1	1				
	Q152004000	TORNIL. APLASTADO M5X13 A 304	FLAT HEADED SCREW M5x13 A 3	4	4				
6	U052401000	TOBERA Ø 1,45 B.P.	NOZZLE Ø 1,45 B.P.	2	2				
6	1011600000	TOBERA Ø 2,25 G.N.	NOZZLE Ø 2,25 G.N.	2	2				
6	X102403000	TOBERA Ø 4,58 G.V.	NOZZLE Ø 4,58 G.V.	2	2				
7	H505047000	DISTRIBUIDOR A QUEMADOR	DISTRIBUTOR TO BURNER	1	1				
	Q306062000	ARANDELA Ø13,9X10,33x1,5	WASHER Ø13.9X10.33x1.5	2	2				
	Q221342000	REMACHE EXAGONAL M5	HEXAGONAL RIVET M5	2	2				
	Q012032000	TORNILLO EXAGONAL M5X15	HEXAGONAL BOLT. M5X15	2	2				
8	U912102000	GRIFO VALVULA CAL 3200	VALVE TAP CAL 3200	1	1				
	U912104000	BRIDA AMARRE GRIFO 1/2"	TAP FASTENING FLANGE 1/2"	1	1				
	Q122032000	TORNILLO ALLEN M.5x15	ALLEN HEAD SCREW M.5x15	1	1				
9	U022117000	MANDO MONTADO Ø8	CONTROL BUTTON Ø8	1	1				
10	H505040000	TUBO PILOTO CPG9-05	PILOT LIGHT PIPE CPG9-05	1	1				
	U195009000	MANGUITO EMPALME	CONNECTION HOSE	1	1				
11	H505042000	DISTRIBUIDOR COMPL. CPG9-05	COMPL.DISTRIBUTOR CPG9-05	1	1				
11	H515044000	DISTRIBUIDOR COMPL. CPG9-05S	COMP. DISTRIBUTOR CPG9-05S	1	1				
11	H045002000	DISTRIBUIDOR COMPL. CPG9-05S	COMP. DISTRIBUTOR CPG9-05S	1	1				
	Q221343000	REMACHE EXAGONAL M6	HEXAGONAL RIVET M6	2	2				
	Q012042000	TORNILLO EXAGONAL M6X15	HEXAGONAL BOLT. M6X15	2	2				
	Q302022000	ARANDELA 16X6X1.2 A.304	WASHER 16X6X1.2 A.304	2	2				
	Q012032000	TORNILLO EXAGON. M5X15	HEXAGONAL BOLT. M5X15	2	2				
	Q302022000	ARANDELA 16X6X1.2 A.304	WASHER 16X6X1.2 A.304	2	2				

Зип Общепит

vsezip.ru

+7(812)987-08-81

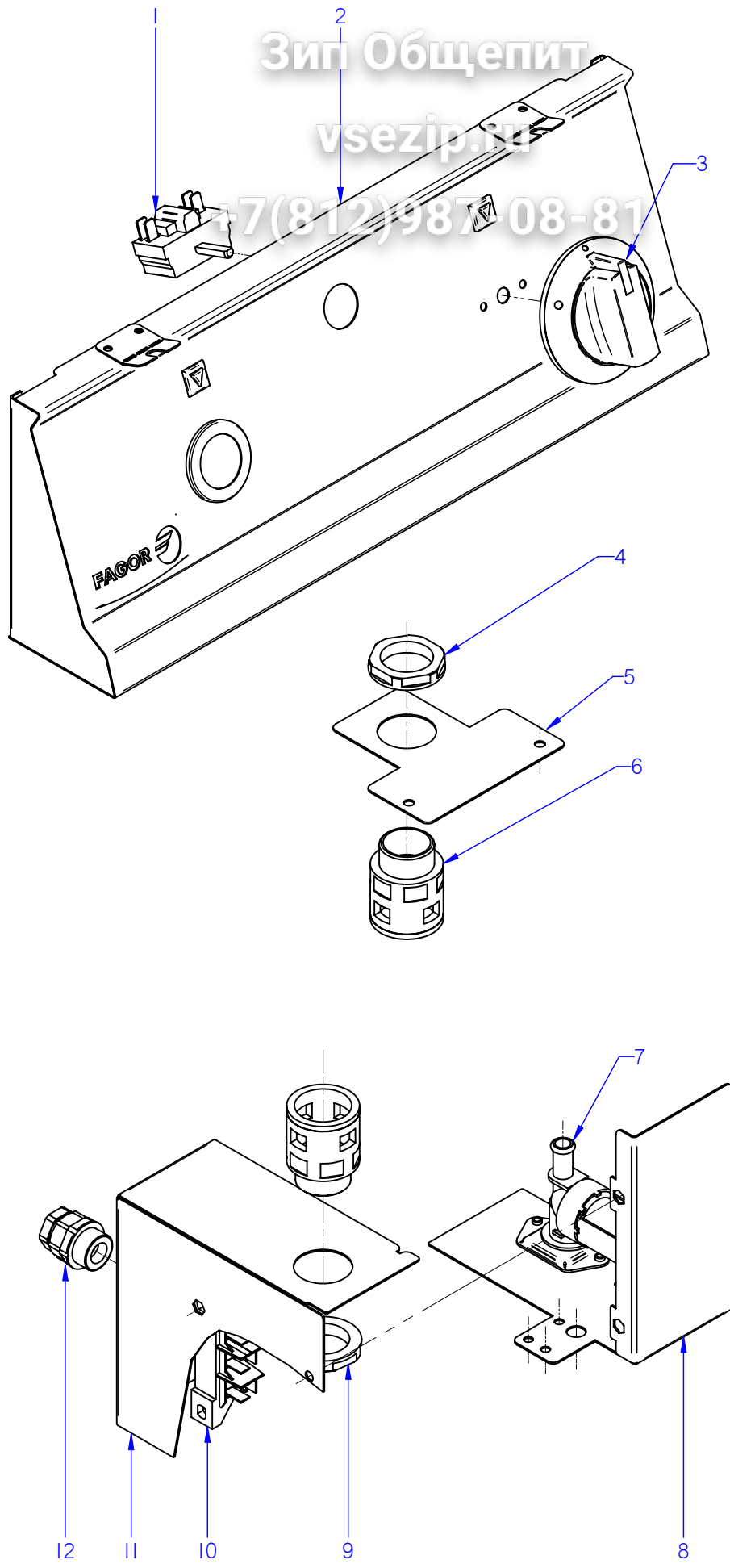

ITEM MARCADO EN COLOR = REPUESTO RECOMENDADO
COLOURED ITEM = RECOMMENDED SPARE PART

N plano	Firma	Fecha	Aparato	CONJUNTO FUNCIONAL ELECTRICO	Lamina	Fagor Industrial S.Coop. FAGOR
C-2203	<i>(Signature)</i>	2009-03	COCEDOR DE PASTA CPG9-05		4	Oñate

Зип Общепит

MOD.		COCEDOR DE PASTA		vsezip.ru		CONJUNTO FUNCIONAL ELECTRICO	
ITEM	CODIGO	DENOMINACION	TEXTO	CPG9-05	CPG9-05 S		
1	T343008000	CONMUTADOR HGC	HGC SWITCH	1	1		
1	R693004000	CONMUTADOR 16A 6V 4pos VDE	16A 6V 4pos VDE SWITCH	1	1		
2	H502806000	PORTAMANDOS COMP. CPG9-05	CONTROL HOLDER CPG9-05	1	1		
2	12041162	PORTAMANDOS COMPL. CPG9-00	CONTROL HOLDER CPG9-00	1	1		
3	X022133000	BOTON DE MANDO Ø6 ENT. AGUA	CONTROL BUTTON Ø6 ENT. WAT	1	1		
3	H503006000	MANDO AGUA COMP. CP900	CONTROL BUTTON CP900	1	1		
4	R023025000	CONTRATUERCA (GAES)	COUNTERNUT (GAES)	1	1		
5	H052609000	SOPORTE RACORD SUPERIOR	UPPER CONNECTION SUPPORT	1	1		
	Q152004000	TORNIL. APLASTADO M5X13 A 304	FLAT HEADED SCREW M5x13 A 3	2	2		
	Q221342000	REMACHE EXAGONAL M5	HEXAGONAL RIVET M5	2	2		
6	X713021000	RACOR QUICK 5020.049.021	QUICK CONNECTION 5020.049.02	2	2		
7	Z701135000	E.V.SIMP.220V COD.255.208	E.V.SIMP.220V COD.255.208	1	1		
7	P255001000	ELECTROV.230V AC 50/60Hz 2 VIA	SOLENOID 230V AC 50/60Hz 2V	1	1		
S/Nº	P443042000	REGULADOR 3L VERDE 254.023	REGULATOR 3L GREEN 254,023	1	1		
S/Nº	12097038	REGULADOR 3L NEGRO 254.023	REGULATOR 3L BLACK 254,023	1	1		
S/Nº	Z601156000	REGULADOR 8L RO. 254.034	REGULATOR 8L RO. 254.034	1	1		
S/Nº	12096626	REGULADOR 8L ROJO	REGULATOR 8L RED	1	1		
S/Nº	Z201106000	RACORD EN Y	CONNECTION Y	1	1		
8	H052605000	CUADRO ELECTRICO CPG9-05	ELECTRIC PANEL CPG9-05	1	—		
8	12041059	CUADRO ELECTRICO CPG9-00	ELECTRIC PANEL CPG9-00	1	1		
8	H052608000	SOPORTE ELECTROVALVULA S	SOLENOID SUPPORT S	—	1		
	Q419005000	REMACHE 4x8 ALMG3 / ALUMINIO	RIVET 4X8 ALMG3 / ALUMINIUM	4	—		
	Q012031000	TORNILLO EXAGONAL M5X10	HEXAGONAL BOLT. M5X10	—	2		
9	R023025000	CONTRATUERCA (GAES)	COUNTERNUT (GAES)	1	1		
10	U183046000	REGLETA AUXILIAR	AUXILIARY STRIP	1	1		
10	Z713035000	REGLETA AUXILIAR 6 MM	AUXILIARY STRIP 6MM	1	1		
11	H052606000	TAPA CUADRO ELECTR. CPG9-05	ELECT. PANEL COVER CPG9-05	1	1		
11	12041066	TAPA CUADRO ELECTRICO	ELECT. PANEL COVER	1	1		
11	H052610000	TAPA REGLETA	TERMINAL STRIP COVER	—	1		
	Q152004000	TORNIL. APLASTADO M5X13 A 304	FLAT HEADED SCREW M5x13 A 3	2	2		
12	R073004000	PRENSA ESTOPAS	STUFFING BOX	1	1		

Зип Общепит

vsezip.ru

+7(812)987-08781

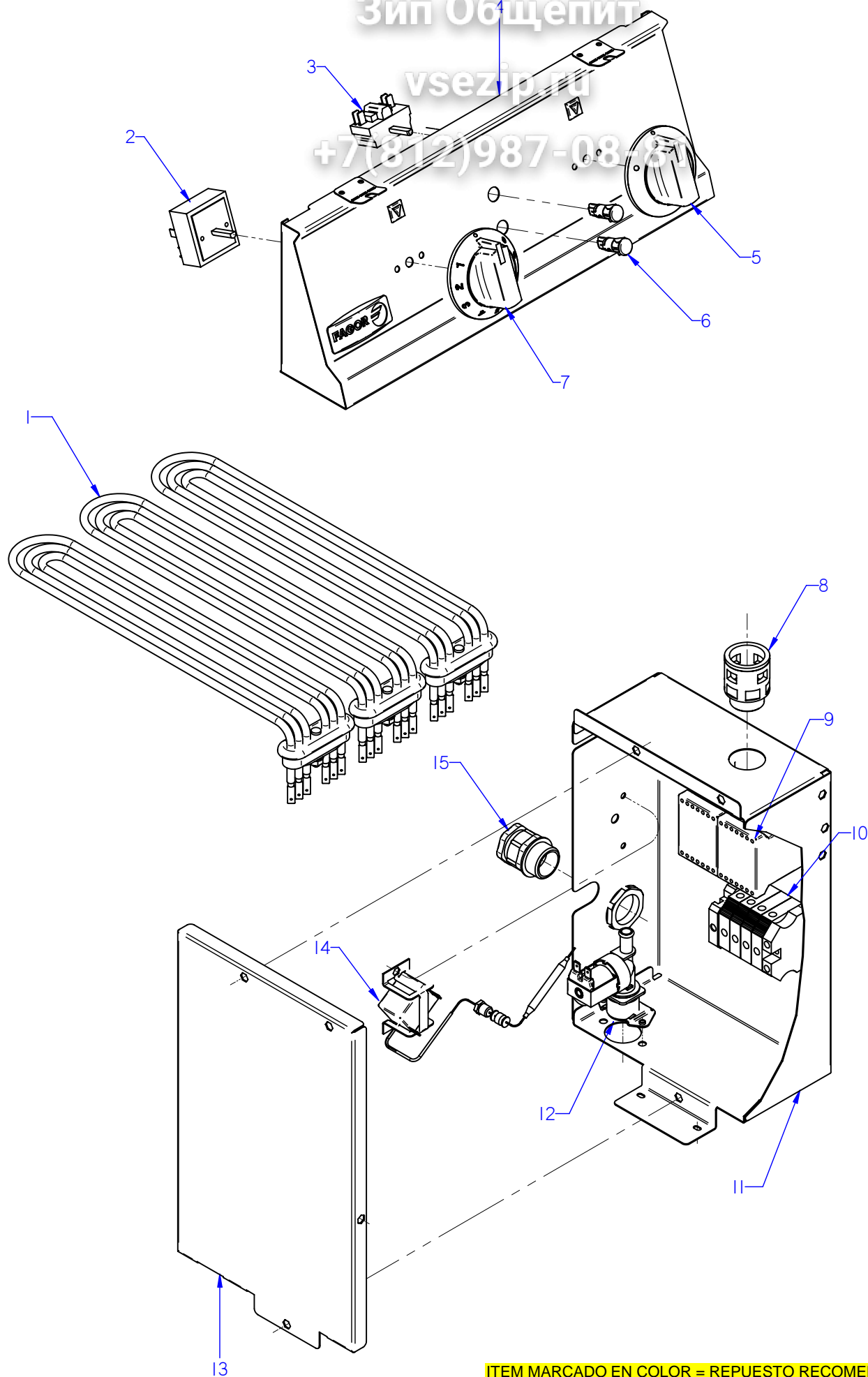

ITEM MARCADO EN COLOR = REPUESTO RECOMENDADO
COLOURED ITEM = RECOMMENDED SPARE PART

N plano	Firma	Fecha	Aparato	CONJUNTO FUNCIONAL ELECTRICO	Lamina	Fagor Industrial S.Coop. FAGOR
C-2204	<i>(Signature)</i>	2009-03	COCEDOR DE PASTA CPE9-05		5	Oñate

Зип Общепит

vsezip.ru

ZONA

CONJUNTO FUNCIONAL ELECTRICO

MOD. COCEDOR DE PASTA

+7(812)987-08-81

ITEM	CODIGO	DENOMINACION	TEXTO	CPE9-05	CPE9-05 S				
1	H063002000	RESISTENCIA 4000W 230V	RESISTOR 4000W 230V	3	3				
2	S333001000	REGULADOR DE ENERGIA	ENERGY REGULATOR	1	1				
3	T343008000	CONMUTADOR HGC	HGC SWITCH	1	1				
3	R693004000	CONMUTADOR 16A 6V 4pos VDE	16A 6V 4pos VDE SWITCH	1	1				
	Q151320000	TORNILLO ALOMADO M4X6 H.ZINC	CURVED SCREW M4X6 H.ZINC	2	2				
4	H062805000	PORTAMANDOS COMPL. CPE-905	CONTROL HOLDER CPE9-05	1	1				
4	H042805000	PORTAMANDOS COMPL. CPE	CONTROL HOLDER CPE	1	1				
5	S162102000	BOTON DE MANDO	CONTROL BUTTON	1	1				
6	R693056000	PILOTO AMBAR 41227000A4	AMBER PILOT 41227000A4	1	1				
6	12024669	PILOTO AMBAR Ø18	AMBER PILOT Ø18	1	1				
S/Nº	R693055000	PILOTO VERDE 41227000C7	GREEN PILOT 41227000C7	1	1				
S/Nº	12047390	PILOTO VERDE 230V AC 8KW 16MM	GREEN PILOT 230V AC 8KW 16MM	1	1				
7	X022133000	BOTON DE MANDO Ø6 ENT. AGUA	CONTROL BUTTON Ø6 ENT. WAT	1	1				
7	H503006000	MANDO AGUA COMP. CP900	CONTROL BUTTON CP900	1	1				
8	X713021000	RACOR QUICK 5020.049.021	CONNECTION ICK 5020.049.021	2	2				
	R023025000	CONTRATUERCA (GAES)	COUNTERNUT (GAES)	2	2				
9	Z203050000	CONTACTOR SIRIUS 3R 230V50-60	CONTACTOR SIRIUS 3R 230V50-60	2	2				
	Z403016000	GUIA CONTACTOR L-100	CONTACTOR GUIDE L-100	1	1				
	Q419005000	REMACHE 4X8 ALMG3 / ALUMINIO	RIVET 4X8 ALMG3 / ALUMINIUM	4	4				
10	P453025000	BORNES 10 WDU-10203.O	TERMINALS 10 WDU-10203.O	3	3				
	P453026000	BORNE TIER 10 WPE-10103.O	TERMINAL TIER 10 WPE-10103.O	1	1				
	Z263302000	BORNA AZUL PASO 16MM	BLUE TAP TERMINAL 16MM	1	1				
	Z263303000	TOPE FINAL	END STOP	1	1				
11	H083007000	CUADRO ELECTRICO CPE9-05	ELECTRIC PANEL CPE9-05	1	—				
11	H083005000	CUADRO ELECTRICO CPE-705	ELECTRIC PANEL CPE-705	—	1				
11	12041217	CUADRO ELECTRICO CPE MEK	ELECTRIC PANEL CPE MEK	1	1				
11	H042635000	CUADRO ELECTRICO CPE AD	ELECTRIC PANEL CPE AD	1	1				
	Z703006000	RACORD A 90 SFWO-P213T	CONNECTION A 90 SFWO-P213T	2	2				
12	Z701135000	E.V.SIMP.220V COD.255.208	E.V.SIMP.220V COD.255.208	1	1				
12	P255001000	ELECTROV.230V AC 50/60Hz 2 VIA	SOLENOID 230V AC 50/60Hz 2V	1	1				

Зип Общепит

MOD.	COCEDOR DE PASTA	ZONA	PIEZAS ESPECIFICAS PARA LOS DISTINTOS
-------------	-------------------------	-------------	--

ITEM	CODIGO	DENOMINACION	TEXTO	CPG9-05	CPG9-05 S			
		BUTANO - PROPANO						
6	U052401000	TOBERA Ø 1,45	NOZZLE Ø 1,45	2	2			
S/N	U136501000	INDICADOR (BUTANO-PROPANO)	INDICATOR (BUTANE-PROPANE	1	1			
		GAS NATURAL						
6	1011600000	TOBERA Ø 2,25	NOZZLE Ø 2,25	2	2			
17	U442137000	INYECTOR Ø 0,40	INJECTOR Ø 0.4	1	1			
S/N	U134402000	INDICADOR (GAS NATURAL)	INDICATOR (NATURAL GAS)	1	1			
		GAS VILLA						
6	X102403000	TOBERA Ø 4,58	NOZZLE Ø 4,58	2	2			
S/N	U134310000	INDICADOR (GAS VILLA)	INDICATOR (TOWN GAS)	1	1			

Зип Общедет
vsezip.ru

+7(812)987-08-81

IG = Interruptor general
L1 = Lámpara funcionamiento
V1 = Válvula Agua Caliente

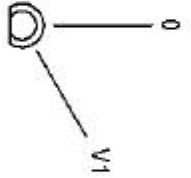
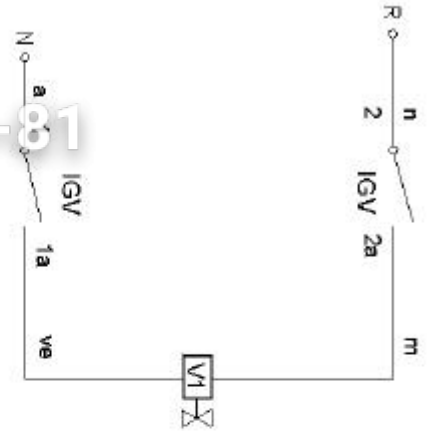

IG	1	2
0	1a	2a
V1	X	X

H503003000

Eskema teorikoa: CPE9-05, CPE9-05S				H503003000		
Zk. J.N°	Pieza	Cant.	Materia/Material	Clas. Zk/J° Clas.	Gainazal akaberat/Tre	
Zk. J.N°	Aldaketak/Modificaciones		Work. proposatuak/Propuesta de	Data/Fecha	Perdoi erokom Tolerancias gene	
-	-	-	-	-	-	
-	-	-	-	-	-	
-	-	-	-	-	-	
-	-	-	-	-	-	
-	-	-	-	-	-	
Sinadura/Firma		Data/Fecha		Gainazal pers Mecanizado supe		
Monzuzua/Dibujado		e.e. arrasol		2008-10-27		
Proiektatua/Proyectado		e.e. arrasol		2008-10-27		
Egokiztatua/Con probado		j. g. h. e. d. e.		2008-10-27		
Eskala/Escala		EGOSKETA				Plano Zk/J.P leno HB-80505
		Plano hau ezin daiteke erabili, ez berrizatu, gure baimenik gabe.				Zk. c Zk. g

Зип Общепит

vsezip.ru

+7(812)987-08-81

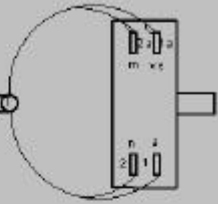

T343000000

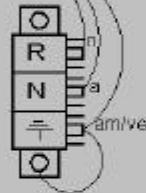

Regleta
U183046



Z701135

Instalazio elektrikoa: CPG9-05	H503001000
Instalazio elektrikoa: CPG9-05 S	H503002000
Eskema teorikoa	H503003000

Muntajeko plana: CPG9-05				H503004000	-	
Zk. N°	Pieza	Cant.	Materiala/Material	Clas. Zk. N° Clas.	Gainazal akabera/Tre	
Zk. N°	Aldaketak/Modificaciones		Nork proposatua/E ropustea da	Data/E fecha	Perdoi erokom Tolerancias gene	
-	-	-	-	-	-	
-	-	-	-	-	-	
-	-	-	-	-	± 5 ± 0.2	
-	-	-	-	-	5 ± 25 ± 0.4	
-	-	-	-	-	25 ± 50 ± 0.6	
Sinadura/Firma		Data/E fecha		Gehiazal peroi Mecanizado (s/e)		
Muntatza/Dibujado		e.e. arreseal		2008-10-27		
Proiektatza/Proyectado		e.e. arreseal		2008-10-27		
Egokiztatza/Com probado		j. g. h. e. d. l.		2008-10-27		
Eskala/Escala		EGOSKETA				Plano Zk. JP lano HB-80506
		Plano hau ezin daiteke erabili, ez berrintzatu, gure baimenik gabe				- Zk. C - Zk. g



Fagor Industrial/Coop. Elk. Mugatua

CPE9-05 / S

Зип Общепит

vsezip.ru

+7(812)987-08-81

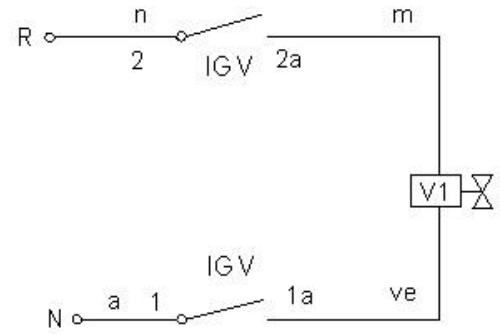
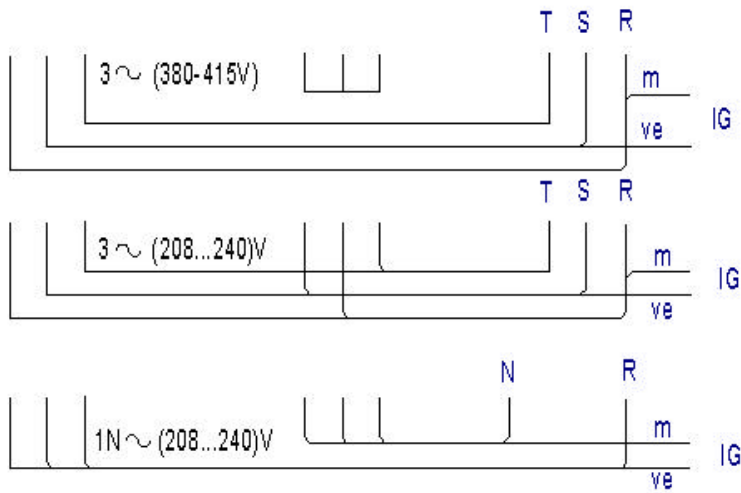
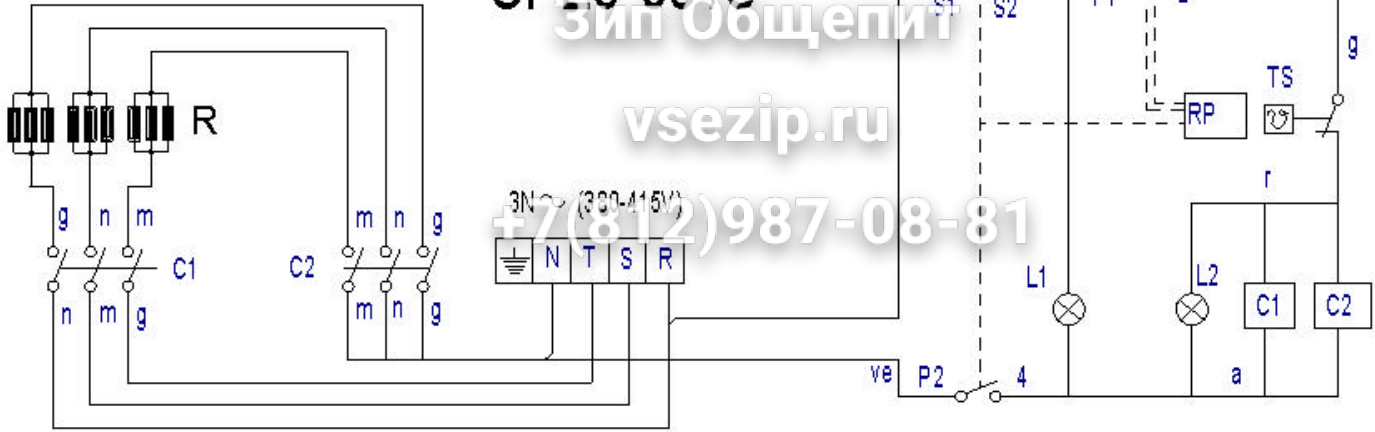

POSICION	% ±2%	P1 - 2		P2 - 4	S1 - S2
		TON	TON+TOF		
0	0	0	∞		
52°	6%	3"	45"	X	X
84°	10%	4"	38"	X	X
116°	15%	5"	32"	X	X
148°	25%	7"	29"	X	X
180°	30%	9"	30"	X	X
212°	40%	13"	32"	X	X
244°	55%	21"	37"	X	X
276°	75%	45"	60"	X	X
308°	100%	∞	∞	X	X

-	Eskemateorikoa: CPE9-05, CPE9-05	
Zk / Nº	P.kza	
Zk / Nº	Aldaketak/Modifikazioak	
-	-	-
-	-	-
-	-	-
-	-	-
-	-	-
	Sinadura/Firma	Data/Fe
Marratza/Dibujado	e.carrascal	2008-10
Proiektatza/Proyectado	e.carrascal	2008-10
Egiaztatza/Com probado	e.aldred	2008-10
Eskala/Escala		
-		
Plano katuzko datuak		

Зип Общепит

vsezip.ru

+7(812)987-08-81

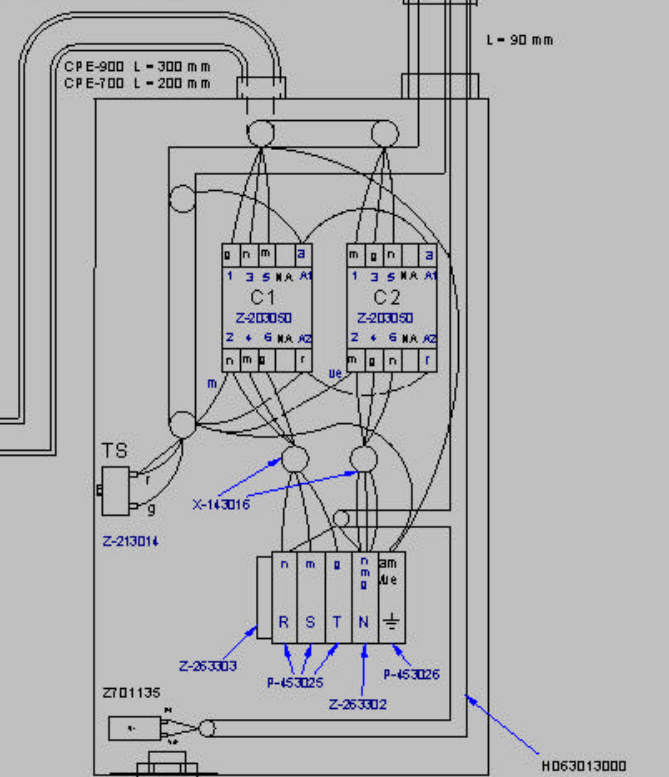
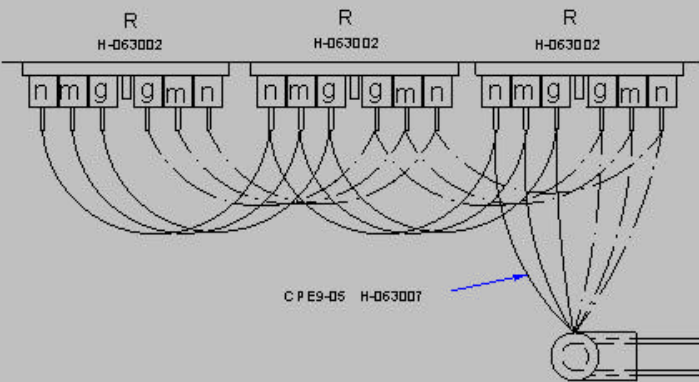
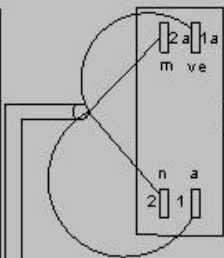
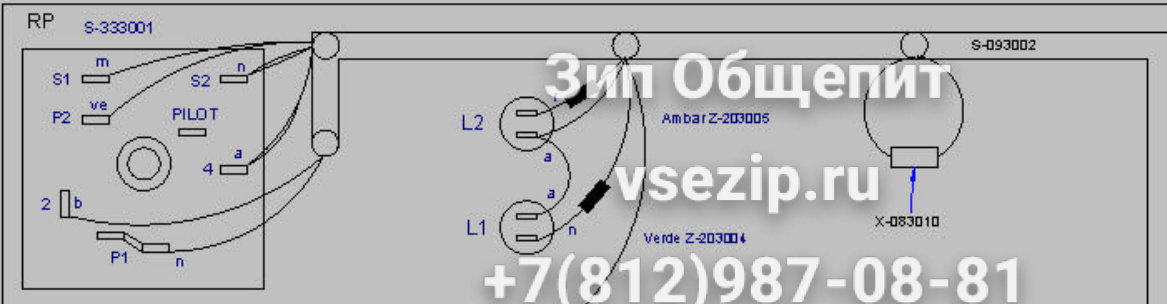

ESKEMA TEORIKOA
CPE9-05 H-063008

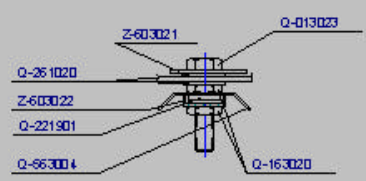

Muntajeko plano: CPE9-05		
Zk / Nº	Pkza	
Zk / Nº	Aldaketak/Modifikazioak	
-	-	-
-	-	-
-	-	-
-	-	-
-	-	-
Marratza/Dibujado	Sinaditza/Firma	Data/Fe
Proiektatza/Proyectado	e.carrascos	2008-10
Egiazatza/Comprobado	e.carrascos	2008-10
Eskala/Escala	2:1	
Plano katezila da luke e...		

Зип Общепит

vsezip.ru

+7(812)987-08-81

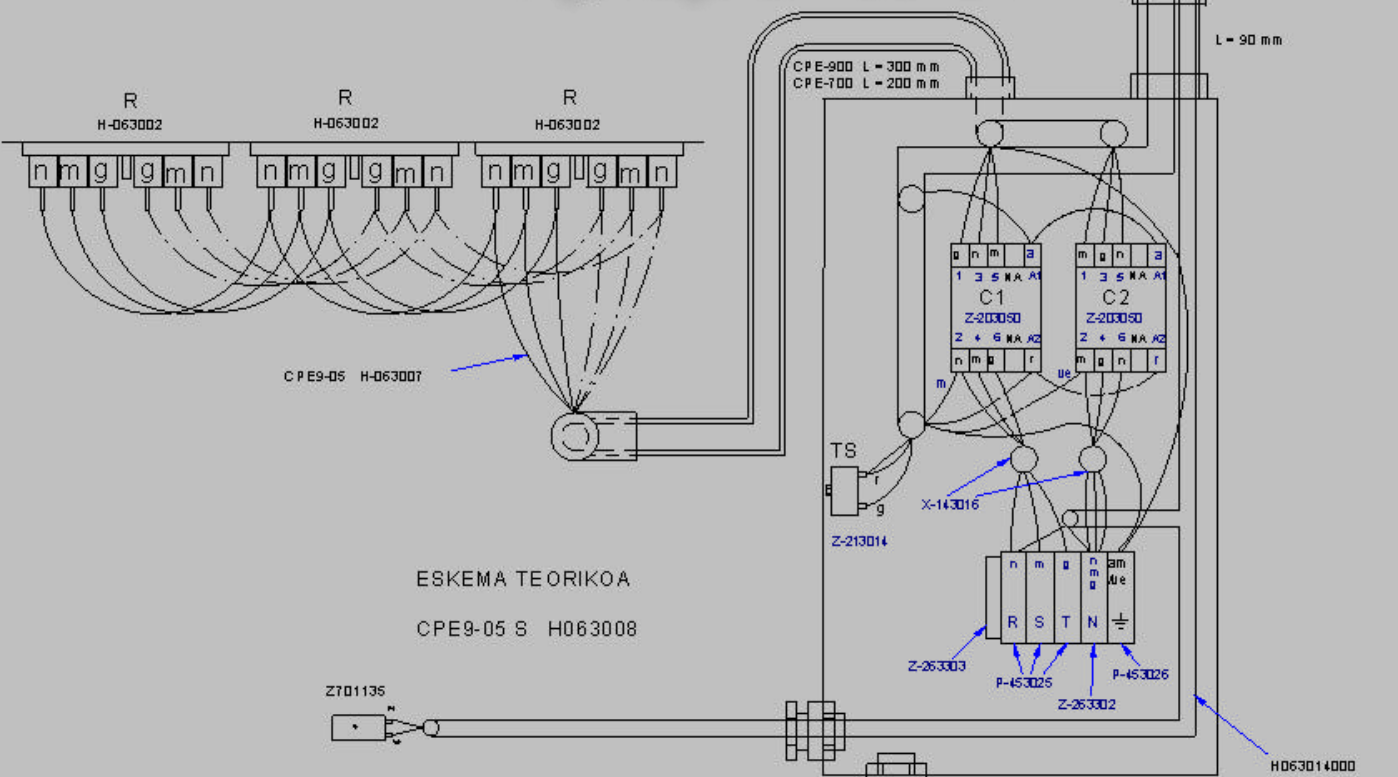
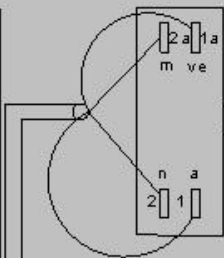
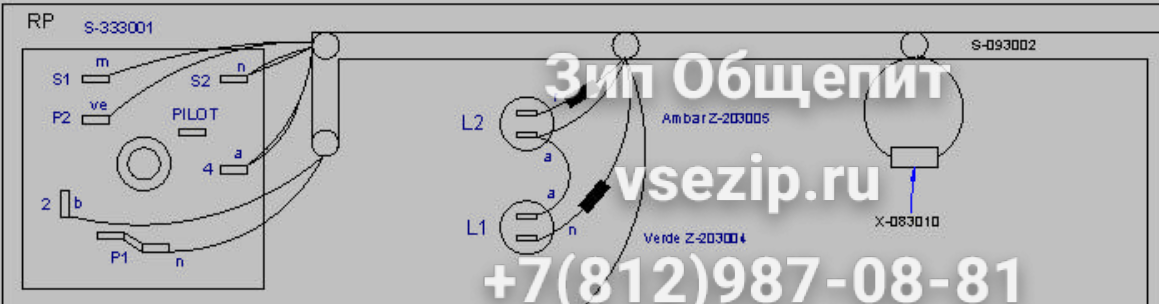

ESKEMA TEORIKOA
CPE9-05 S H063008

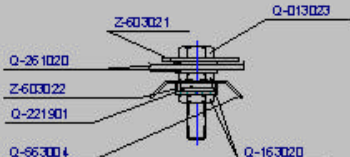

Muntajeko planoak: CPE9-05 S		
Zk / Nº	P kza	
Zk / Nº	Aldaketak/Modifikazioak	
-	-	-
-	-	-
-	-	-
-	-	-
-	-	-
Marratza/Diratzaio	Sinadura/Firma	Data/Fe
Proiektatza/Proyektado	e.carrascos	2008-10
Egiazta/Comprobado	e.carrascos	2008-10
Eskala/Escala	1:1	
Plano katezila/Rele...		