

Зип Общепит

vsezip.ru

DESPIECE TECNICO

+7(812)987-08-81

Hornos a gas
Fours à gaz
Gas ovens
Gas heissluftdämpfer
Forni a gas
Fornos a gás

Modelos:

COG-102

VG-102

VPG-102

Diciembre 2010 December

Revisado Octubre 2012 / Revised October 2012

FAGOR 

F A G O R I N D U S T R I A L

Зип Общепит

ysezip.ru

+7(812)987-08-81

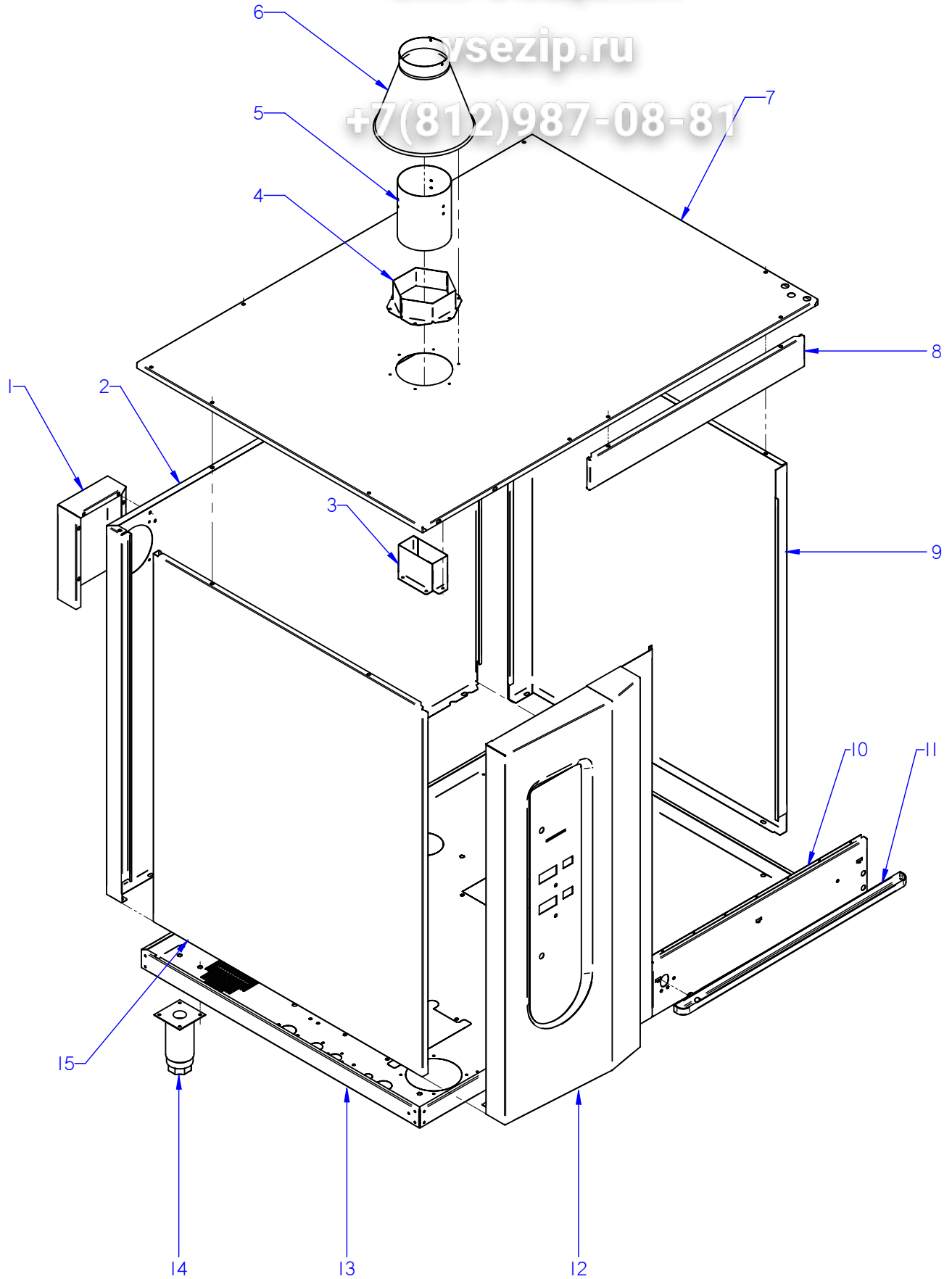

ITEM MARCADO EN COLOR = REPUESTO RECOMENDADO
COLOURED ITEM = RECOMMENDED SPARE PART

N plano	Firma	Fecha	Aparato	MUEBLE / UNIT	Lamina	Fagor Industrial S.Coop. FAGOR
C-2764	<i>(Signature)</i>	2010-12		HORNOS COG-102	1	Oñate

MOD.	HORNOS / OVEN	ZONA / ZONE	MUEBLE / UNIT					
ITEM	CODIGO CODE	DENOMINACION	NAME	COG-102				
1	T812806500	CHAPA SEPARACION IPX5	SEPARATION PLATE IPX5	1				
S/Nº	T812811000	JUNTA IPX5	SEAL IPX5	1				
	Q221342000	REMACHE EXAGONAL M5	HEXAGONAL RIVET M.5	6				
	Q232030000	ARANDELA A5	WASHER A.5	6				
	Q242030000	ARANDELA ABANICO A5 A.304	FAN SHAPED WASHER A.5	6				
	Q012031000	TORNILLO EXAGONAL M5x10 A304	HEXAGONAL SCREW M.5x10	6				
2	T612802000	PANEL POST. EXTERIOR 10/21	REAR EXTERIOR PANEL210/21	1				
	Q221342000	REMACHE EXAGONAL M5	HEXAGONAL RIVET M5	4				
3	T012605000	CHIMENEA INTERIOR COMPLETA	COMPLETE INTER. FLUEPIPE	2				
	Q412002000	REMACHE AVINOX Ø4x10	AVINOX RIVET Ø4x10	4				
4	T832610000	GUIA CHIMENEA	FLUEPIPE GUIDANCE	2				
	Q412002000	REMACHE AVINOX Ø4x10	AVINOX RIVET Ø4x10	6				
5	R292646500	CONDUCTO HUMOS	SMOKE DUCT	1				
6	R272612000	CHIMENEA	FLUEPIPE	1				
S/Nº	R272614000	SOPORTE CHIMENEA HCG/HGC	CHIMNEY SUPPORT	3				
	Q412002000	REMACHE AVINOX Ø4x10	AVINOX RIVET Ø4x10	15				
7	T632801000	PANEL SUPERIOR EXTERIOR HGC	EXTERIOR UPPER PANEL HGC	1				
	Q152004000	TORNILLO APLASTADO M5x13	FLAT HEAD SCREW M5X13	7				
	Q232030000	ARANDELA A5	WASHER A.5	2				
	Q242030000	ARANDELA ABANICO A5 A.304	FAN WASHER A5 A.304	2				
	Q012032000	TORNILLO EXAGONAL M5x15	HEXAGONAL BOLT M5x15	2				
8	T642810000	PANEL FRONTAL SUPERIOR	UPPER FRONT PANEL	1				
	Q221342000	REMACHE EXAGONAL M5	HEXAGONAL RIVET M.5	2				
	Q412005000	REMACHE AVINOX Ø3,2X6	RIVET AVINOX Ø3,2X6	7				
	Q232040000	ARANDELA A6	WASHER A.6	6				
	Q242040000	ARANDELA ABANICO A6 A.304	FAN SHAPED WASHER A.6	6				
	Q012042000	TORNILLO EXAGONAL M6x15	HEXAGONAL BOLT M6x15	6				
9	T642812000	PANEL EXTERIOR DERECHO 10/21	RIGHT EXT. PANEL 10/21	1				
	Q221342000	REMACHE EXAGONAL M5	HEXAGONAL RIVET M.5	2				
10	T642811000	PANEL FRONTAL INFERIOR	LOWER FRONT PANEL	1				

Зип Общепит

vsezip.ru

+7(812)987-08-81

MOD.	HORNOS / OVEN	ZONA / ZONE	MUEBLE / UNIT					
ITEM	CODIGO CODE	DENOMINACION	NAME	COG-102				
11	T302853000	RECOGEAGUAS PLASTICO	PLAST SPRING WATER COLLE.	1				
	Q222041000	REMACHE EXAGONAL M.4 INOX.	HEXAGONAL M.4 INOX.	4				
12	T632803000	PANEL PORTAMANDOS HEI 10/21	CONTROL PANEL HEI 10/21	1				
	Q221342000	REMACHE EXAGONAL M5	HEXAGONAL RIVET M.5	3				
S/Nº	T612806000	JUNTA PORTAMAND. HORZ 10/21	CONTROL HOLDER SEAL HORZ	1				
13	T612801000	BASE EXTERIOR 10/21E	EXTERIOR BASE 10/21E	1				
	Q221343000	REMACHE EXAGONAL M.6	HEXAGONAL RIVET M.6	33				
	Q221342000	REMACHE EXAGONAL M.5	HEXAGONAL RIVET M.5	6				
14	X260151000	PATA REGULABLE	REGULABLE LEG	4				
	Q232040000	ARANDELA A6	WASHER A.6	16				
	Q242040000	ARANDELA ABANICO A6 A.304	FAN SHAPED WASHER A.6	16				
	Q012043000	TORNILLO EXAGONAL M6x20	HEXAGONAL BOLT M6x20	16				
15	T642816000	PANEL EXTER. IZQUIERDO 10/21	REAR LEFT PANEL 10/21	1				
	Q221342000	REMACHE EXAGONAL M.5	HEXAGONAL RIVET M.5	2				
	Q232040000	ARANDELA A6	WASHER A.6	2				
	Q242040000	ARANDELA ABANICO A6 A.304	FAN SHAPED WASHER A.6	2				
	Q012042000	TORNILLO EXAGONAL M6x15	HEXAGONAL BOLT M6x15	2				
	Q152004000	TORNIL. APLASTADO M5X13 A 304	FLAT SCREW M.5x13	2				
	Q242020000	ARANDELA ABANICO A4 A.304	FAN SHAPED WASHER A.4	2				
	Q032021000	TORNILLO ALOMADO M4x10	CURVED SCREW M.4x10	2				

Зип Общепит

vsezip.ru

+7(812)987-08-81

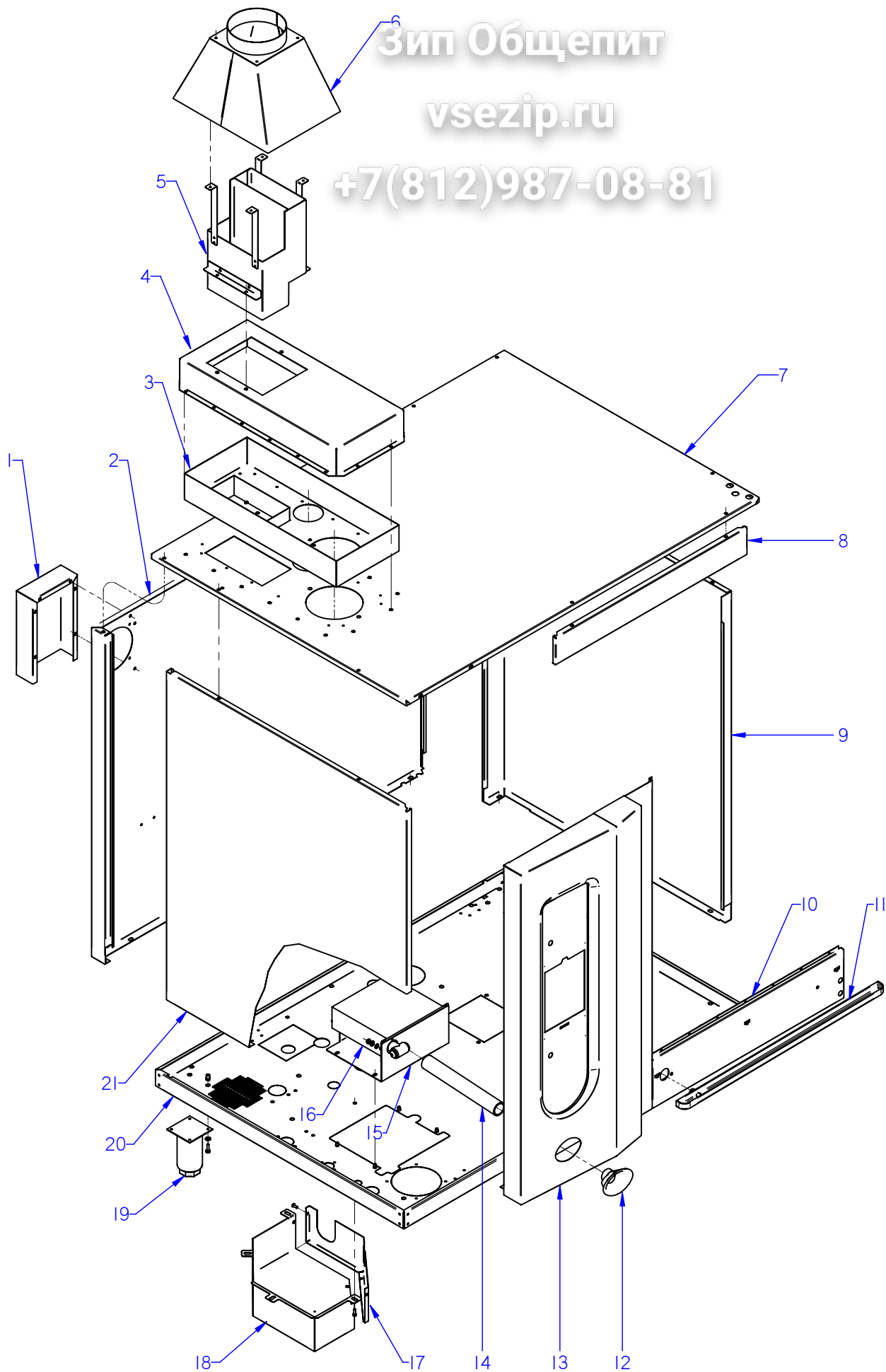

ITEM MARCADO EN COLOR = REPUESTO RECOMENDADO
COLOURED ITEM = RECOMMENDED SPARE PART

N plano	Firma	Fecha	Aparato	MUEBLE / UNIT	Lamina	Fagor Industrial S.Coop. FAGOR
C-2765	<i>(Signature)</i>	2010-12	HORNOS	VG-102 / VPG-102	2	Oñate

MOD.	HORNOS / OVEN	ZONA / ZONE	MUEBLE / UNIT					
ITEM	CODIGO CODE	DENOMINACION	NAME	VG-102	VPG-102			
1	T512807000	CHAPA SEPARACION IPX5	SEPARATION PLATE IPX5	1	1			
	Q221342000	REMACHE EXAGONAL M5	HEXAGONAL RIVET M.5	6	6			
	Q232030000	ARANDELA A5	WASHER A.5	6	6			
	Q242030000	ARANDELA ABANICO A5 A.304	FAN SHAPED WASHER A.5	6	6			
	Q012031000	TORNILLO EXAGONAL M5x10 A304	HEXAGONAL SCREW M.5x10	6	6			
S/Nº	T512808000	JUNTA IPX5	SEAL IPX5	1	1			
2	T642813000	PANEL POST. EXTERIOR 10/21	REAR EXTERIOR PANEL210/21	1	1			
	Q221342000	REMACHE EXAGONAL M5	HEXAGONAL RIVET M5	4	4			
3	T642818000	BANDEJA DE COLECTOR	MANIFOLD TRAY	1	1			
3	T642819000	BANDEJA DE COLECTOR COMPL.	COMPL. MANIFOLD TRAY	1	1			
	Q412002000	REMACHE TUBULAR Ø4x7.5	TUBULAR RIVET Ø4x7.5	15	15			
4	T642820500	TAPA COLECTOR 102	TOP MANIFOLD 102	1	1			
	3715200000	JUNTA CRISTAL	GLASS SEAL	2	2			
	Q012042000	TORNILLO EXAGONAL M6x15	HEXAGONAL BOLT M6x15	3	3			
	Q232030000	ARANDELA A5	WASHER A.5	3	3			
	Q242030000	ARANDELA ABANICO A5 A.304	FAN SHAPED WASHER A.5	3	3			
	Q162040000	TUERCA EXAGONAL M6	HEXAGONAL NUT M6	3	3			
5	T122816000	SALIDA DE COLECTOR COMPL.	COMPL. MANIFOLD OUTPUT	1	1			
S/Nº	T112815000	SOPORTE DE CHIMENEA	CHIMNEY SUPPORT	4	4			
6	T122820000	CHIMENEA EXTERIOR COMPLETA	COMPLETE EXTERIOR FLUEPIPE	1	1			
	Q412002000	REMACHE TUBULAR Ø4x7.5	TUBULAR RIVET Ø4x7.5	12	12			
	Q152004000	TORNILLO APLASTADO M5x13	FLAT HEAD SCREW M5X13	3	3			
	Q242030000	ARANDELA ABANICO A5 A.304	FAN WASHER A5 A.304	3	3			
7	T642817000	PANEL SUPERIOR EXTERIOR	EXTERIOR UPPER PANEL	1	1			
	Q222011000	REMACHE EXAGONAL M5 INOX	HEXAGONAL RIVET M5	16	16			
	Q152004000	TORNILLO APLASTADO M5x13	FLAT HEAD SCREW M5X13	7	7			
	Q232030000	ARANDELA A5	WASHER A.5	2	2			
	Q242030000	ARANDELA ABANICO A5 A.304	FAN WASHER A5 A.304	2	2			
	Q012032000	TORNILLO EXAGONAL M5x15	HEXAGONAL BOLT M5x15	2	2			

MOD.	HORNOS / OVEN	ZONA / ZONE	MUEBLE / UNIT					
ITEM	CODIGO CODE	DENOMINACION	NAME	VG-102	VPG-102			
8	T642810000	PANEL FRONTAL SUPERIOR	UPPER FRONT PANEL	1	1			
	Q221342000	REMACHE EXAGONAL M5	HEXAGONAL RIVET M.5	6	6			
	Q412005000	REMACHE AVINOX Ø3,2X6	RIVET AVINOX Ø3,2X6	7	7			
	Q232040000	ARANDELA A6	WASHER A.6	6	6			
	Q242040000	ARANDELA ABANICO A6 A.304	FAN SHAPED WASHER A.6	6	6			
	Q012042000	TORNILLO EXAGONAL M6x15	HEXAGONAL BOLT M6x15	6	6			
9	T642812000	PANEL EXTERIOR DERECHO 10/21	RIGHT EXT. PANEL 10/21	1	1			
	Q221342000	REMACHE EXAGONAL M5	HEXAGONAL RIVET M.5	2	2			
10	T642811000	PANEL FRONTAL INFERIOR	LOWER FRONT PANEL	1	1			
11	T302853000	RECOGEAGUAS PLASTICO	PLAST SPRING WATER COLLE.	1	1			
	Q222041000	REMACHE EXAGONAL M.4 INOX.	HEXAGONAL M.4 INOX.	4	4			
12	T922801000	EMBELLECEDOR DUCHA	SHOWER TRIM	1	1			
13	T642822000	PANEL PORTAMANDOS VG-102	CONTROL PANEL 1VG-102	1	-			
13	T652803000	PANEL PORTAMANDOS VPG-102	CONTROL PANEL 1VPG-102	-	1			
	Q221342000	REMACHE EXAGONAL M5	HEXAGONAL RIVET M.5	3	3			
S/Nº	T612806000	JUNTA PORTAMAND. HORZ 10/21	CONTROL HOLDER SEAL HORZ	1	1			
14	3714100000	TUBO SILICONA Ø 38*31	SILICON PIPE Ø 38*31	1	1			
	Q881305000	ABRAZADERA 25*40	CLAMP 25*40	2	2			
15	T642815000	AMARRE DUCHA 10/21 COMPLETO	SHOWER FASTENING	1	1			
16	T452809000	DUCHA	SHOWER	1	1			
S/Nº	T452834000	MANGO DUCHA	SHOWER HANDLE	1	1			
	Q232030000	ARANDELA A5	WASHER A.5	4	4			
	Q242030000	ARANDELA ABANICO A5 A.304	FAN SHAPED WASHER A.5	4	4			
	Q012031000	TORNILLO EXAGONAL M5x10 A304	HEXAGONAL SCREW M.5x10	4	4			
17	T650702000	TAPA CUBRE SISTEMA LAVADO	COVER WASHING SYSTEM BOX	-	1			
17	T330752500	TAPA SISTEMA LAVADO	TOP WASHING SYSTEM	-	1			
	Q242030000	ARANDELA ABANICO A5 A.304	FAN SHAPED WASHER A.5	-	9			
	Q152004000	TORNILLO APLAST. M5X13 A 304	FLAT SCREW M.5x13	-	9			
18	T650701500	CAJA CUB SIST LIMP VPG 202 SOL.	CLEANING SYSTEM BOX	-	1			
18	T330753000	CAJA CUBRE BOMBA LAVADO	CLEANING PUMP BOX	-	1			
	Q221342000	REMACHE EXAGONAL M5	HEXAGONAL RIVET M.5	-	9			

MOD.		HORNOS / OVEN		ZONA / ZONE		MUEBLE / UNIT		
ITEM	CODIGO CODE	DENOMINACION	NAME	VG-102	VPG-102			
S/Nº	T550702000	GUIA1 CAJA CUBRE SIST LAVADO	GUIDE1 WASHING SYSTEM BOX	-	1			
S/Nº	T550701000	GUIA2 CAJA CUBRE SIST LAVADO	GUIDE2 WASHING SYSTEM BOX	-	1			
19	X260151000	PATA REGULABLE	REGULABLE LEG	4	4			
	Q232040000	ARANDELA A6	WASHER A.6	16	16			
	Q242040000	ARANDELA ABANICO A6 A.304	FAN SHAPED WASHER A.6	16	16			
	Q012043000	TORNILLO EXAGONAL M6x20	HEXAGONAL BOLT M6x20	16	16			
20	T642801000	BASE EXTERIOR 10/21	EXTERIOR BASE 10/21	1	1			
	Q221343000	REMACHE EXAGONAL M.6	HEXAGONAL RIVET M.6	35	10			
	Q221342000	REMACHE EXAGONAL M.5	HEXAGONAL RIVET M.5	35	10			
21	T642816000	PANEL EXTER. IZQUIERDO 10/21	REAR LEFT PANEL 10/21	1	1			
	Q221342000	REMACHE EXAGONAL M.5	HEXAGONAL RIVET M.5	2	2			
	Q232040000	ARANDELA A6	WASHER A.6	2	2			
	Q242040000	ARANDELA ABANICO A6 A.304	FAN SHAPED WASHER A.6	2	2			
	Q012042000	TORNILLO EXAGONAL M6x15	HEXAGONAL BOLT M6x15	2	2			
	Q152004000	TORNIL. APLASTADO M5X13 A 304	FLAT SCREW M.5x13	2	2			
	Q242020000	ARANDELA ABANICO A4 A.304	FAN SHAPED WASHER A.4	2	2			
	Q032021000	TORNILLO ALOMADO M4x10	CURVED SCREW M.4x10	2	2			

Зип Ощепит

vsezip.ru

+7(812)987-08-81

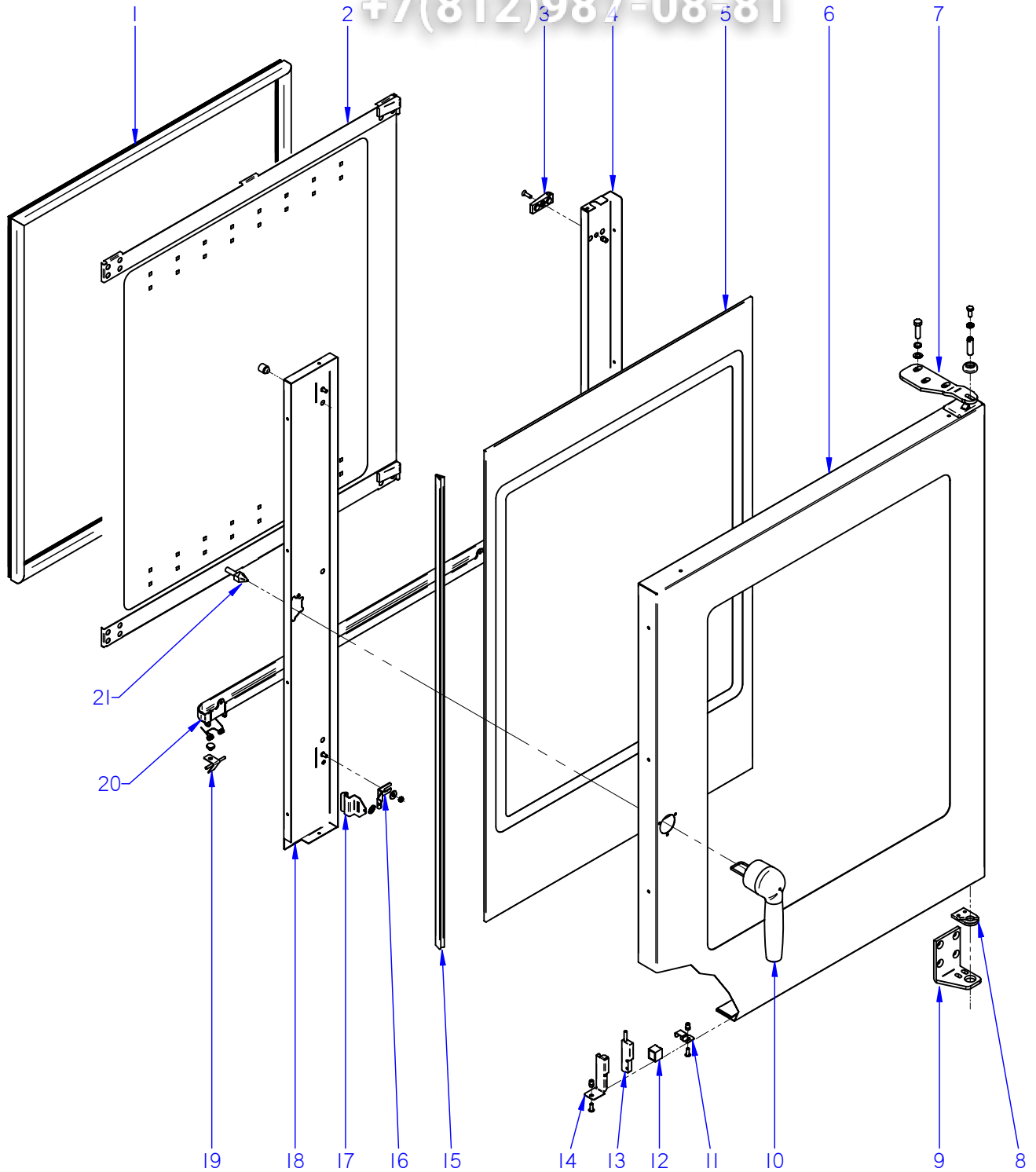

ITEM MARCADO EN COLOR = REPUESTO RECOMENDADO
COLOURED ITEM = RECOMMENDED SPARE PART

N plano	Firma	Fecha	Aparato	PUERTA / DOOR	Lamina	Fagor Industrial S.Coop. FAGOR
C-2766	<i>[Signature]</i>	2010-12	HORNOS COG / VG / VPG-102		3	Oñate

MOD.		HORNOS / OVEN	ZONA / ZONE	PUERTA / DOOR		
ITEM	CODIGO CODE	DENOMINACION	NAME	COG-102	VG-102	VPG-102
	1100003143	KIT PUERTA 10/21 COMPL.	DOOR 10/21 KIT	1	1	1
1	T300500000	JUNTA DE PUERTA 10/21	DOOR JOINT 10/21	1	1	1
2	1100003136	KIT CRISTAL INTER. 10/21	10/21 INNER GLASS KIT	1	1	1
3	R670615000	BASE DE BISAGRA	HINGE BASE	2	2	2
	Q042032000	TORNILLO AVELLANADO M5X15	COUNTERSUNK SCREW M.5x15	2	2	2
4	T640504000	CONTRAPUERTA BISAGRA 10/21	INNER DOOR HINGE 10/21	1	1	1
5	T300546000	CRISTAL EXTERIOR 10/21	EXTERNAL GLASS 10/21	1	1	1
6	T640502000	PANEL PUERTA 10/21	DOOR PANEL 10/21	1	1	1
7	T300520500	BISAGRA SUPERIOR 10/21	UPPER HINGE 10/21	1	1	1
7	T300520000	BISAGRA SUPERIOR 21	UPPER HINGE 21	1	1	1
	Q302025000	ARANDELA 8,4X20X1.5	WASHER 8,4X20X1.5	3	3	3
	Q261050000	ARANDELA MUELLE A8	SPRING WASHER A8	3	3	3
	Q012055000	TORNILLO EXAGONAL M8X30	HEXAGONAL BOLT M8X30	3	3	3
S/Nº	R660534000	EJE SUPERIOR	UPPER SHAFT	1	1	1
	R662807000	ARANDELA AMARRE	DOOR ANCHORING WASHER	1	1	1
	Z850519000	RESORTE 06329	SPRING 06329	1	1	1
8	R660549000	GUIA EJE INFERIOR FUNDIDO	LOWER SHAFT GUIDE	1	1	1
	Q062040000	TORNILLO AVELLANADO M6X16	COUNTERSUNK SCREW M.6x16	4	4	4
9	T300521000	BISAGRA INFERIOR	LOWER HINGE	1	1	1
10	T900506000	MANILLA COMPLETA	HANDLE	1	1	1
	Q042022000	TORNILLO AVELLANADO M4X15	COUNTERSUNK SCREW M.4x15	3	3	3
11	T130513000	SOPORTE IMAN	MAGNET HOLDER	1	1	1
	Q222011000	REMACHE EXAGONAL M.5	HEXAGONAL RIVET M.5	1	1	1
	Q242030000	ARANDELA ABANICO A5 A.304	FAN SHAPED WASHER A.5	1	1	1
	Q152004000	TORNIL. APLASTADO M5X13 A 304	FLAT SCREW M.5x13	1	1	1
12	Z200506000	IMAN	MAGNET	1	1	1
S/Nº	Z200507000	PROTECTOR IMAN	MAGNET PROTECTOR	1	1	1
13	Z100522000	INTERRUPTOR MAGNETICO AC	MAGNETIC SWITCH AC	1	1	1
14	T302819000	SOPORTE MICRO PUERTA	DOOR MICRO SWITCH	1	1	1
	Q152004000	TORNIL. APLASTADO M5X13 A 304	FLAT SCREW M.5x13	1	1	1
15	3715200000	JUNTA CRISTAL	WINDOW SEAL	2	2	2

MOD.		HORNOS / OVEN	ZONA / ZONE	PUERTA / DOOR				
ITEM	CODIGO CODE	DENOMINACION	NAME	COG-102	VG-102	VPG-102		
16	R670612000	BASE DE PESTILLO	LATCH BASE	2	2	2		
17	T300514000	PESTILLO	LATCH	2	2	2		
	R660605000	MUELLE TENSOR	LATCH TENSOR SPRING	2	2	2		
	Q302022000	ARANDELA 16X6X1.2 A.304	FLAT WASHER 16x6x1,2	2	2	2		
	Q242030000	ARANDELA ABANICO A5 A.304	FAN SHAPED WASHER A.5	2	2	2		
	Q162030000	TUERCA EXAGONAL M5	HEXAGONAL NUT M.5	2	2	2		
18	T640506000	CONTRAP MANILLA COMPL 10/21	COMPLETE HANDLE DOOR 10/21	1	1	1		
	T300513000	TOPE CRISTAL INTERIOR	INTERIOR GLASS BUFFER	4	4	4		
19	T300543000	CIERRE RECOGEAGUAS	WATER COLLECTOR COVER	1	1	1		
	T300518000	TAPON CIERRE CANALETA	CAP CHANNEL COVER	1	1	1		
	T840510000	JUNTA CIERRE RECOGEAGUAS	JOINT WATER COLLECTOR COV	1	1	1		
	T840509000	MUELLE CIERRE RECOGEAGUAS	SPRING WATER COLLECTOR CO	1	1	1		
20	T300556000	RECOGEAGUAS PUERTA	DOOR SPRING WATER COLLECT	1	1	1		
	Q042022000	TORNILLO AVELLANADO M4X15	COUNTERSUNK SCREW M.4x15	2	2	2		
21	T900507000	ANCLAJE PUERTA	DOOR ANCHORING	1	1	1		

Зип Общепит

vsezip.ru

+7(812)987-08-81

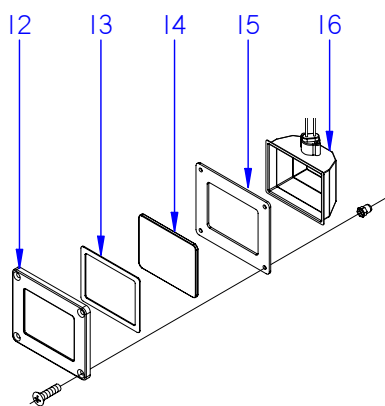

DETALLE DE LAMPARA

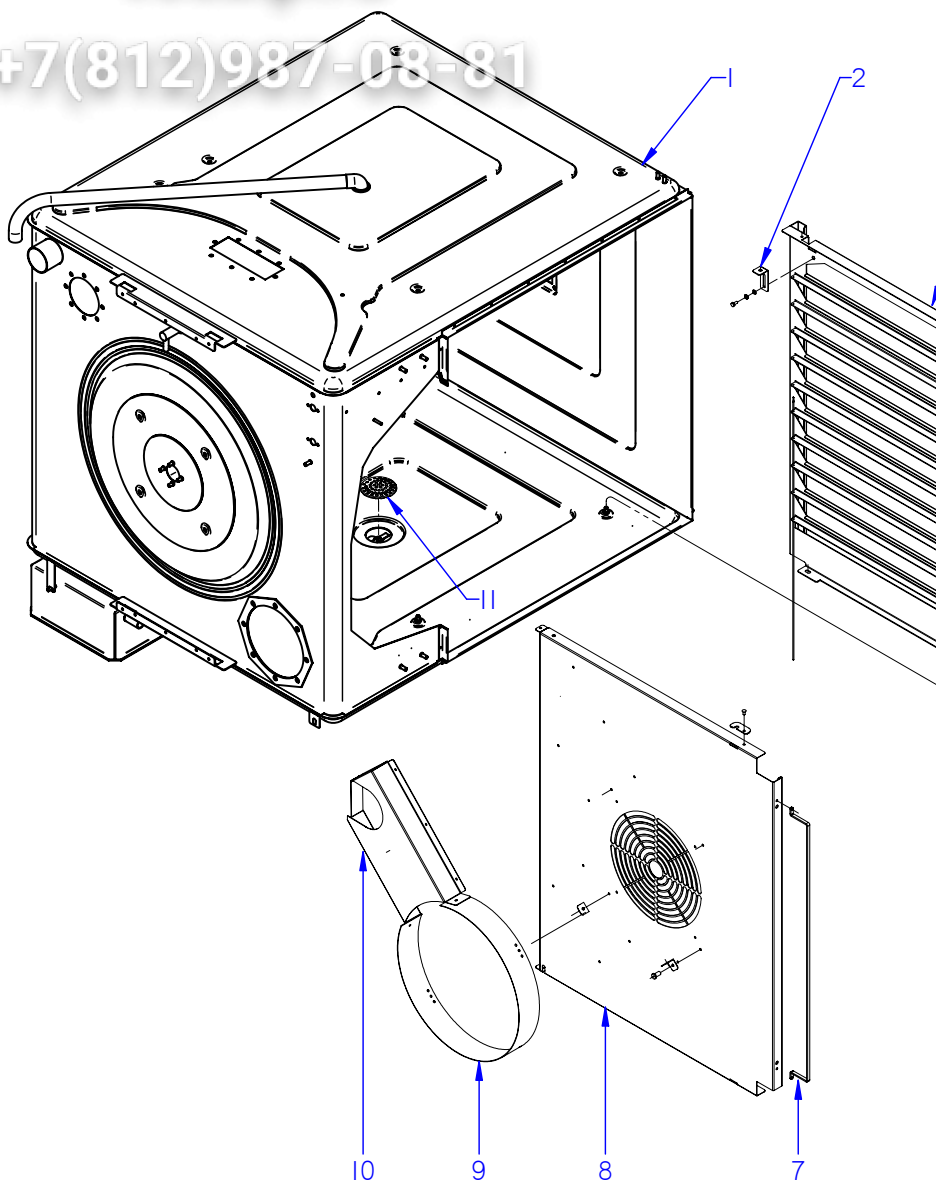

N plano	C-2767
Firma	<i>[Signature]</i>
Fecha	2010-12
Aparato	HORNOS COG- / VG / VPG-102
MUEBLE INTERIOR / INTERIOR OVEN	
Lamina	4
Fagor Industrial S. Coop. Oñate	FAGOR

ITEM MARCADO EN COLOR = REPUESTO RECOMENDADO
COLOURED ITEM = RECOMMENDED SPARE PART

MOD.	HORNOS / OVEN	ZONA / ZONE	MUEBLE INTERIOR / INTERIOR OVEN			
ITEM	CODIGO CODE	DENOMINACION	NAME	COG-102	VG-102	VPG-102
1	T632601000	CUERPO INTERIOR HGC-20/21	INTERIOR BODY HGC -20/21	1	-	-
1	T642603000	CUERPO INTERIOR HGV-20/21	INTERIOR BODY HGV -20/21	-	1	-
1	T652601000	CUERPO INTERIOR HGP-10/21	INTERIOR BODY HGP -10/21	-	-	1
S/Nº	T360712000	PUNTA DIFUSORA LAVADO	WASHING DISPENSER POINT	-	-	1
	Q222042000	REMACHE EXAGONAL R. M6	HEXAGONAL RIVET R. M6	4	4	4
	Q232040000	ARANDELA A6	WASHER A.6	4	4	4
	Q242040000	ARANDELA ABANICO A6 A.304	FAN SHAPED WASHER A.6	4	4	4
	Q012042000	TORNILLO EXAGONAL M6x15	HEXAGONAL BOLT M6x15	4	4	4
2	T302690000	CIERRE PORTABANDEJAS 10/21	TRAY HOLDER CLOSURE 10/21	2	2	2
	Q012021000	TORNILO EXAGONAL M4X10	HEXAGONAL BOLT M4x10	2	2	2
	Q242020000	ARANDELA ABANICO A.4 A304	FAN WASHER A.4 A304	2	2	2
	Q232020000	ARANDELA A-4	WASHER A-4	2	2	2
	Q221341000	REMACHE EXAGONAL M4	HEXAGONAL RIVET M4	2	2	2
3	T322611000	PORTABANDEJAS 1021	TRAY HOLDER 1021	2	2	2
S/Nº	T302692000	TOPE DE BANDEJAS 10/21	TRAY BUFFER 10/21	2	2	2
4	T302688000	ENGANCHE PORTABANDEJAS	TRAY HOLDER FASTENER	2	2	2
	Q412006000	REMACHE AVINOX 4x12	RIVET AVINOX 4x12	2	2	2
5	R682676000	PARRILLA 2x1 REF. 2025200	GRILLE 2X1 REF. 2025200	1	1	1
6	R032605000	CUBETA 530x650 400 MM. 2x1	TRAY 530x650 400 MM. 2x1	1	1	1
7	T302618000	PROTECCION INTERIOR	INTERIOR PROTECTION	1	1	1
	Q412002000	REMACHE AVINOX Ø4x10mm	RIVET AVINOX Ø4x10mm	2	2	2
8	T342609000	CUBREVENTILADOR 10/21	FAN COVER 10/21	1	1	1
S/Nº	T302635000	ENGANCHE CUBREVENTILADOR	FAN COVER FASTENER	2	2	2
S/Nº	T302643000	FIJACIÓN SUPLEMENTO	SUPPLEMENTARY FASTENING	3	3	3
	Q412002000	REMACHE AVINOX Ø4x10mm	RIVET AVINOX Ø4x10mm	6	6	6
9	T302642000	SUPLEMENTO CUBREVENTILAD.	FAN COVER SUPPLEMENT.	1	1	1
10	T342604000	CONDUCTO DE HUMOS HGC	SMOKE DUCT HGC	1	-	-
10	T302641000	CONDUCTO DE HUMOS	SMOKE DUCT	-	1	1
11	T642657000	FILTRO DESAGÜE	DRAINAGE FILTER	1	1	1

MOD.	HORNOS / OVEN	ZONA / ZONE	MUEBLE INTERIOR / INTERIOR OVEN
------	----------------------	-------------	--

ITEM	CODIGO CODE	DENOMINACION	NAME	COG-102	VG-102	VPG-102		
12	T303047000	MARCO LAMPARA	LAMP FRAME	1	1	1		
	R663013000	LAMPARA 10W-12V	LAMP 10W-12V	1	1	1		
	Q222041000	REMACHE EXAGONAL M.4 INOX	HEXAGONAL RIVET M4 (INOX)	4	4	4		
	Q032021000	TORNILLO ALOMADO M4X10	CURVED SCREW M4X10	4	4	4		
13	T303027000	JUNTA INTERIOR LAMPARA	LAMP INTERIOR SEAL	1	1	1		
14	T303025000	CRISTAL LAMPARA	LAMP GLASS	1	1	1		
15	T303026000	JUNTA EXTERIOR LAMPARA	LAMP EXTERIOR SEAL	1	1	1		
16	T303023000	PORTALAMPARAS	LAMP HOLDER	1	1	1		

Зип Общепит

vsezip.ru

+7(812)987-08-81

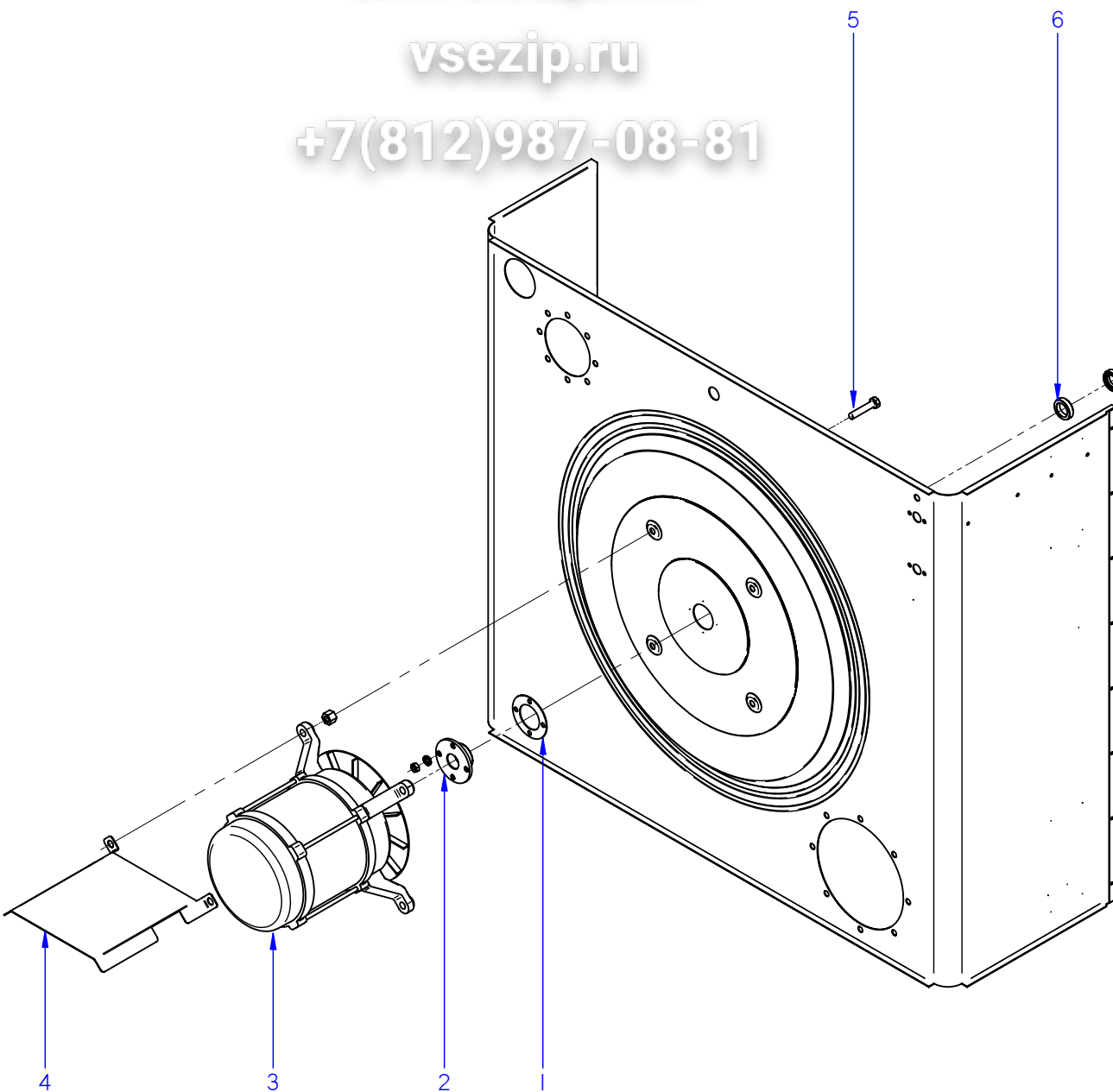

ITEM MARCADO EN COLOR = REPUUESTO RECOMENDADO
COLOURED ITEM = RECOMMENDED SPARE PART

N plano	Firma	Fecha	Aparato	Lamina	Fagor Industrial S. Coop. 
C-2768		2010-12	HORNOS COG / VG / VPG-102 TURBINA / TURBINE	5	Ortfe

Зип Общепит

vsezip.ru

+7(812)987-08-81

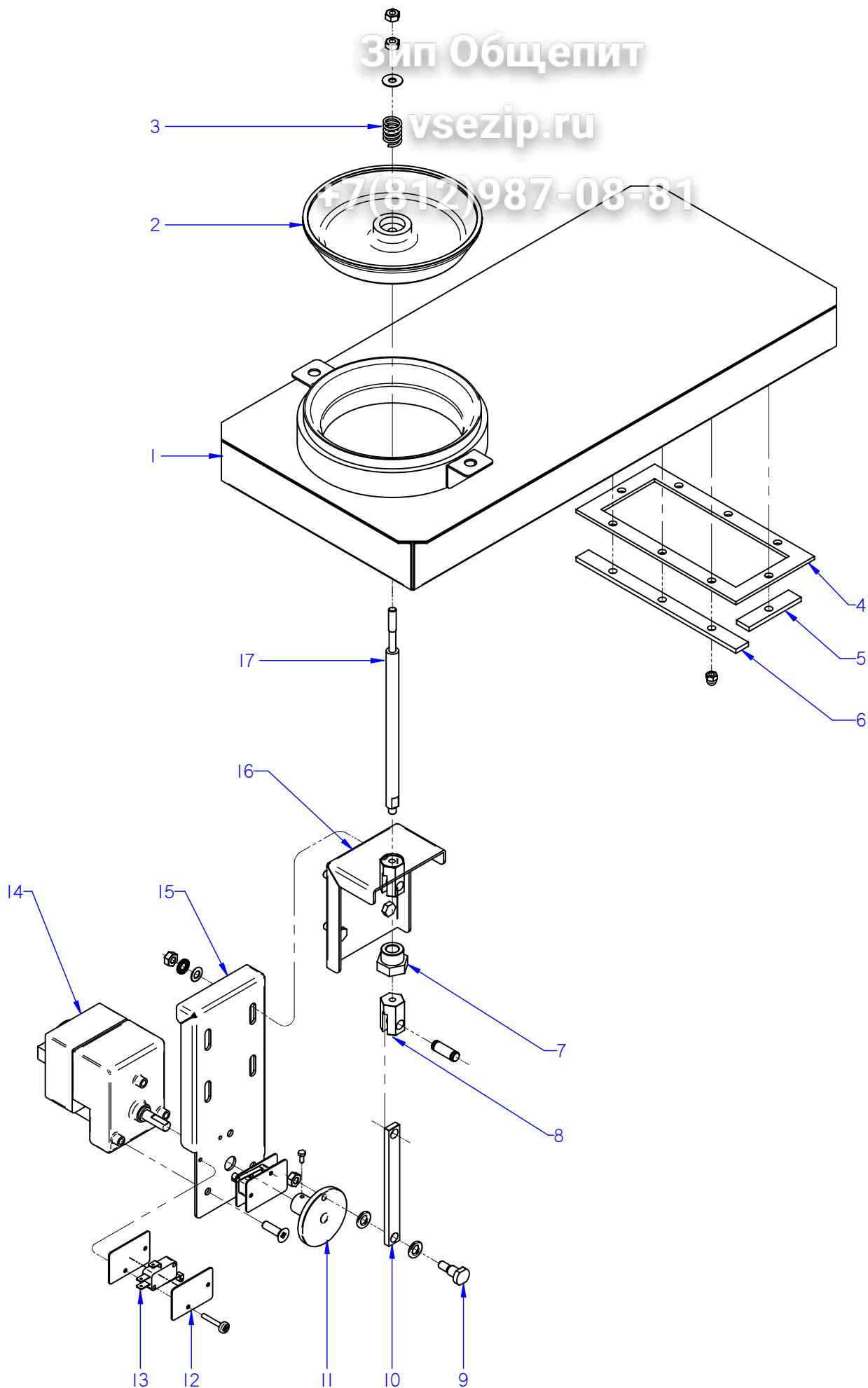

ITEM MARCADO EN COLOR = REPUESTO RECOMENDADO
COLOURED ITEM = RECOMMENDED SPARE PART

N plano	Firma	Fecha	Aparato	CHIMENEA / CHIMNEY	Lamina	Fagor Industrial S.Coop. FAGOR
C-2769	<i>(Signature)</i>	2010-12	HORNOS VG-102 / VPG-102		6	Oñate

MOD.	HORNOS / OVEN	ZONA / ZONE	CHIMENEA / CHIMNEY					
ITEM	CODIGO CODE	DENOMINACION	NAME	VG-102	VPG-102			
1	T642604000	CHIMENEA COM. 10/21	COMPLET. CHIMNEY 10/21	1	1			
1	T652602000	CHIMENEA COM. HGP 10/21	COMPLET. CHIMNEY HGP 10/21	1	1			
2	T125027000	RETENCION DE VAPORES	CLOSE CHIMNEY	1	1			
3	R725008000	RESORTE	SPRING	1	1			
	Q302022000	ARANDELA 16X6X1.2 A.304	FLAT WASHER 16x6x1,2	2	2			
	Q162040000	TUERCA EXAGONAL M6	HEXAGONAL NUT M.6	2	2			
4	T122630000	JUNTA CHIMENEA	FLUEPIPE SEAL	1	1			
5	T132635000	REFUERZO CORTO SU. CHIMENEA	REINFORCIN. CHIMNEY COURT	2	2			
6	T122631000	REFUERZO LARGO INFERIOR	REINFORCIN. LONG BOTTOM	2	2			
	Q213131000	TUERCA SOMBRERETE M5	SOMBRERETE NUT M5	8	8			
7	R725030000	TUERCA GUIA RETENCION	RETAINER NUT GUIDE	1	1			
	Q307067000	JUNTA TORICA 9.19x2.62	O-RING 9.19x2.62	1	1			
8	T135045000	SUPLEMEN. EJE DE RETENCION	AXIS CHARGE RETENTION	1	1			
S/Nº	T135046000	EJE DE GUIA DE RETENCION	GUIDE SHAFT HOLDING	1	1			
	Q271033000	ARANDELA DE SEGURIDAD 6	SAFETY WASHER 6	2	2			
9	T135009000	EJE DE LEVA	CAM SHAFT	1	1			
	Q308013000	ARANDELA Ø14xØ8x2	FLAT WASHER Ø14xØ8x2	2	2			
	Q162040000	TUERCA EXAGONAL M6	HEXAGONAL NUT M.6	1	1			
10	T845012000	PALANCA DE ELEVACION	LIFT LEVER	1	1			
11	T135012000	LEVA	CAM	1	1			
	Q151320000	TORNILLO ALOMADO M4X6 ZINC.	CURVED SCREW M4X6 ZINC.	2	2			
12	R010535000	PLACA SEPARADORA	SPACER PLATE	4	4			
	Q032013000	TORNILLO ALOMADO M3X20	CURVED SCREW M3X20	4	4			
	Q221350000	TUERCA AUTOBLOCANTE M3	SELF-LOCKING NUT M3	4	4			
13	R010534000	INTERRUPTOR PUERTA	DOOR SWITCH	2	2			
14	T113010000	MOTOR CHIMENEA	FLUEPIPE MOTOR	1	1			
14	T843011000	MOTOR CHIMENEA A GAS	FLUEPIPE MOTOR	1	1			
	Q042031000	TORNILLO AVELLANADO M5x10	COUNTERSUNK SCREW M.5x15	3	3			

MOD.		HORNOS / OVEN	ZONA / ZONE	CHIMENEA / CHIMNEY				
ITEM	CODIGO CODE	DENOMINACION	NAME	VG-102	VPG-102			
15	T845011000	ESCUADRA AMARRE MOTOR	MOTOR FASTENING BRACKET	1	1			
	Q232040000	ARANDELA A6	FLAT WASHER A.6	4	4			
	Q242040000	ARANDELA ABANICO A6 A.304	FAN SHAPED WASHER A.6	4	4			
	Q162040000	TUERCA EXAGONAL M6	HEXAGONAL NUT M.6	4	4			
16	T845025000	SOPORTE AMARRE MOTOR	TIE BRACKET MOTOR	1	1			
17	T135044000	EJE DE RETENCION DE VAPORES	VAPOR CHECK SHAFT	1	1			

Зип Общепит

vsezip.ru

+7(812)987-08-81

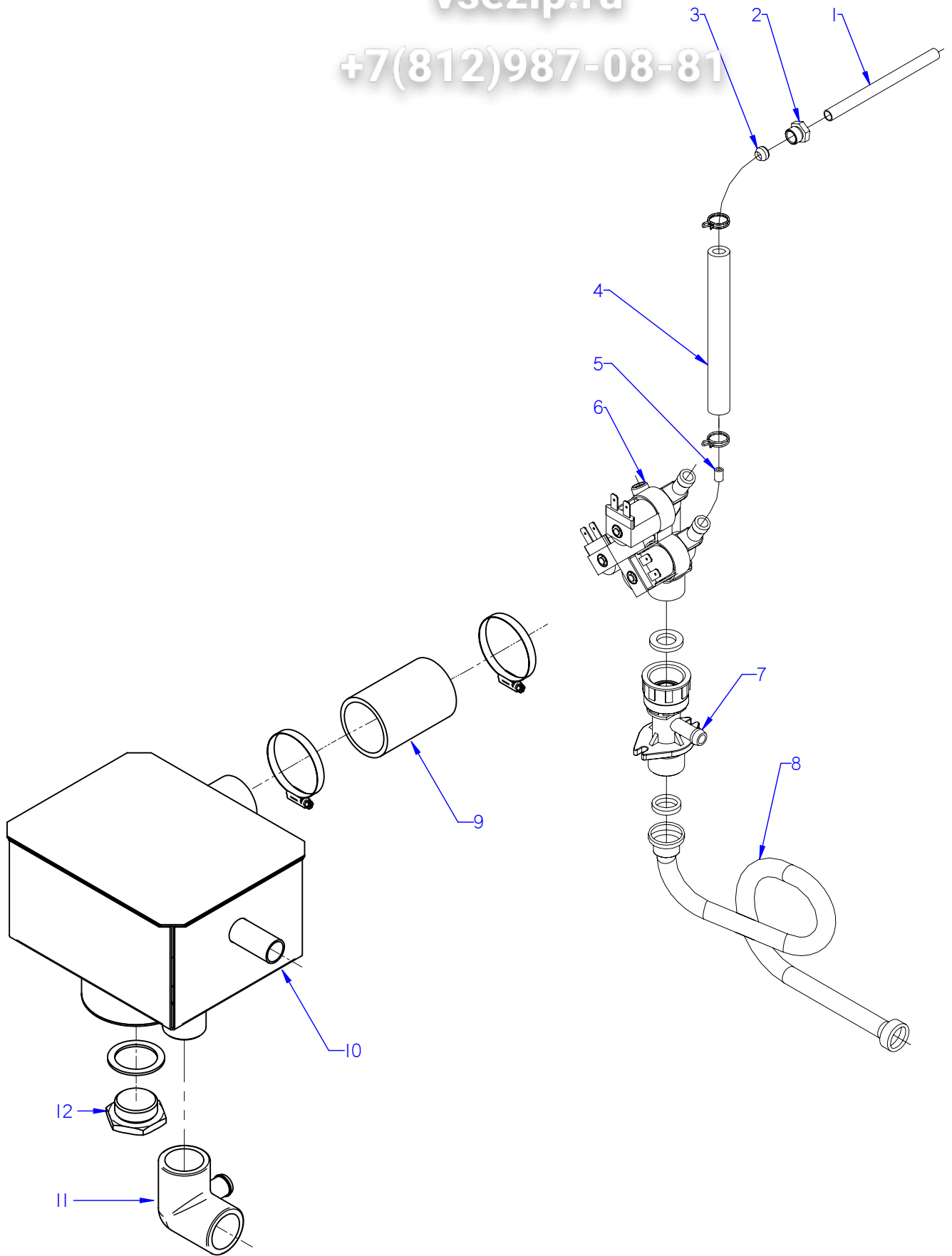

ITEM MARCADO EN COLOR = REPUESTO RECOMENDADO
COLOURED ITEM = RECOMMENDED SPARE PART

N plano	Firma	Fecha	Aparato	CONDUCCIONES DE AGUA / WATER PIPES	Lamina	Fagor Industrial S.Coop. FAGOR
C-2770	<i>[Signature]</i>	2010-12	HORNOS COG-102 / VG-102	7	Oñate	

Зип Ощепит

MOD.		HORNOS / OVEN		ZONA / ZONE		CONDUCCIONES DE AGUA / WATER PIP	
ITEM	CODIGO CODE	DENOMINACION	NAME	COG-102	VG-102		
1	R665024000	TUBO CONDUCCION INYECTOR	INJECTOR DUCT PIPE	1	1		
2	R695003000	MANGUITO CIERRE	CLOSING SLEEVE	1	1		
3	R695004000	BICONO	BICONE	1	1		
4	3676900000	TUBO GOMA NEGRA Ø17*10	BLACK RUBBER PIPE Ø17*10	1	1		
	Q901310000	ABRAZADERA ELASTICA 16.8-17.7	ELASTIC CLAMP 16.8-17.7	2	2		
5	R715011000	REGULADOR 0,5L NARANJA	0.5 L ORANGE REGULATOR	1	—		
5	R665041000	REGULADOR 0,25L ROJO	0.25 L RED REGULATOR	—	1		
6	Z701135000	E.V.SIMP.220V COD.255.208	E.V.SIMP.220V COD.255.208	1	—		
6	Z611123000	ELECTR. TRIPLE COD.255.641	TRIPLE SOLENOID VALVE 255.6	—	1		
7	T645006000	ENTRADA DE AGUA COMPLETA	COMPLETE WATER INLET	—	1		
	Q307031000	JUNTA TUBO 14X24X3	JOINT 14X24X3	—	2		
	Q012021000	TORNILLO EXAGONAL M4x10 A304	HEXAGONAL BOLT M4x10 A304	—	2		
	Q162020000	TUERCA EXAGONAL M4	HEXAGONAL NUT M.4º	—	2		
8	Z601114000	MANGUERA ENTRADA AGUA	WATER INTAKE HOSE	1	1		
9	3715800000	TUBO SILICONA ALTA Tª Ø43*57	HIGH SILICON PIPE Tª Ø43*57	1	1		
	Q901312000	ABRAZADERA ELASTI. Ø50,6-53,2	ELAST. CLAMP Ø50,6-53,2	2	2		
10	T835001000	CAJA DESAGÜE COMPL. HGC	COMPL. DRAINAGE BOX G HGC	1	—		
10	T645001000	CAJA DESAGÜE COMPL. HG V	COMPL. DRAINAGE BOX G HG V	—	1		
	Q232040000	ARANDELA A6	WASHER A6	1	1		
	Q242040000	ARANDELA ABANICO A6	FAN WASHER A6	1	1		
	Q012042000	TORNILLO EXAGONAL M6X15 A304	HEXAGONAL BOLT M6X15 A304	1	1		
11	R665080000	CODO DESAGÜE	DRAIN ELBOW	1	1		
12	T305052000	TAPÓN DESAGÜE	DRAINING PLUG	1	1		
	T305053000	JUNTA DESAGÜE	DRAINAGE BOARD	1	1		

Зип Общепит

vsezip.ru

+7(812)987-08-81

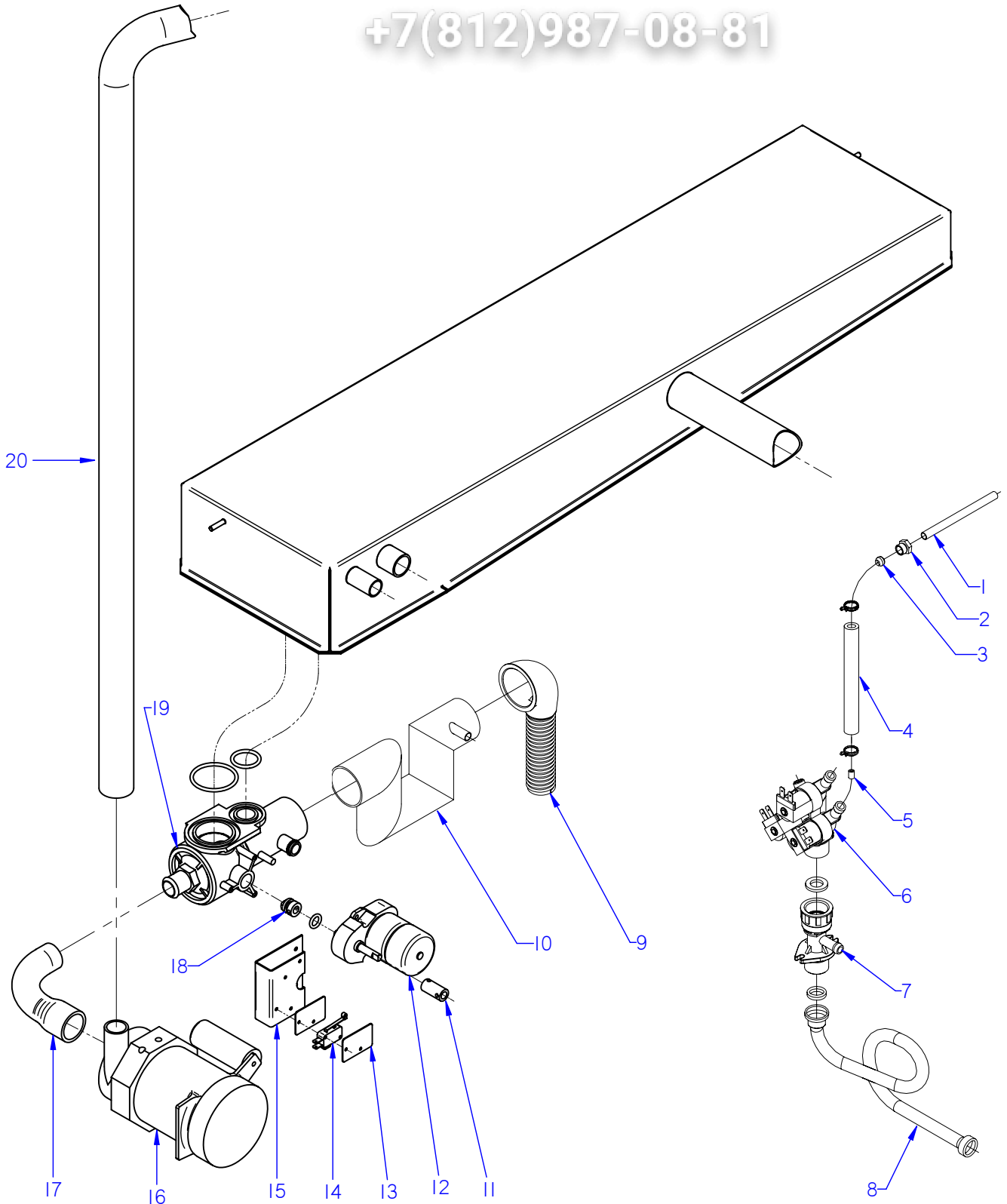

ITEM MARCADO EN COLOR = REPUESTO RECOMENDADO
COLOURED ITEM = RECOMMENDED SPARE PART

N plano	Firma	Fecha	Aparato	CONDUCCIONES DE AGUA / WATER PIPES	Lamina	Fagor Industrial S.Coop. FAGOR
C-2771	<i>(Signature)</i>	2010-12	HORNOS VPG-102		8	Oñate

MOD.	HORNOS / OVEN	ZONA / ZONE	CONDUCCIONES DE AGUA / WATER PIP					
ITEM	CODIGO CODE	DENOMINACION	NAME	VPG-102				
S/Nº	1100003163	KIT VALVULA DE LAVADO COMP.	WASHING VALVE KIT	1				
1	R665024000	TUBO CONDUCCION INYECTOR	INJECTOR DUCT PIPE	1				
2	R695003000	MANGUITO CIERRE	CLOSING SLEEVE	1				
3	R695004000	BICONO	BICONE	1				
4	3676900000	TUBO GOMA NEGRA Ø17*10	BLACK RUBBER PIPE Ø17*10	1				
	Q901310000	ABRAZADERA ELASTICA 16.8-17.7	ELASTIC CLAMP 16.8-17.7	1				
5	R665041000	REGULADOR 0,25L ROJO	0.25 L RED REGULATOR	1				
6	Z611123000	ELECTR. TRIPLE COD.255.641	TRIPLE SOLENOID VALVE 255.6	1				
7	T645006000	ENTRADA DE AGUA COMPLETA	COMPLETE WATER INLET	1				
	Q307031000	JUNTA TUBO 14X24X3	JOINT 14X24X3	2				
	Q012021000	TORNILLO EXAGONAL M4x10 A304	HEXAGONAL BOLT M4x10 A304	2				
	Q162020000	TUERCA EXAGONAL M4	HEXAGONAL NUT M.4º	2				
8	Z601114000	MANGUERA ENTRADA AGUA	WATER INTAKE HOSE	1				
9	Z200910000	MANGUERA DESAGUE	DRAINAGE HOSE	1				
10	T360718000	SIFON SALIDA VALVULA	VALVE OUTPUT SIPHON	1				
	Q881307000	ABRAZADERA 40-60	CLAMP 40-60	1				
11	T330733000	CASQUILLO MOTOR MICRO	MICRO MOTOR BUSHING	1				
	Q151320000	TORNILLO ALOMADO M4X6 H.ZIN.	CURVED SCREW M4X6 H.ZIN.	2				
	Q371026000	MANGUITO SUJEC. 4X14 DIN1481	HOSE FASTENING 4X14 DIN1481	1				
	Q052032000	TORNILLO ALLEN M.5x15(+)	ALLEN HEAD SCREW M.5x15(+)	2				
12	T330711000	MOTOR VALVULA	VALVE MOTOR	1				
	Q042022000	TORNILLO AVELLANADO M4X15	COUNTERSUNK SCREW M.4x15	2				
13	R010535000	PLACA SEPARADORA	SPACER PLATE	4				
	Q032013000	TORNILLO ALOMADO M3X20	CURVED SCREW M3X20	4				
	Q221350000	TUERCA AUTOBLOCANTE M3	SELF-LOCKING NUT M3	4				
14	R010534000	INTERRUPTOR PUERTA	DOOR SWITCH	2				
15	T330713000	CHAPA SUJECCION MICROS	FASTENING PLATE MICROS	1				
15	T330754000	SOPORTE MICROS LAVADO	MICROS WASH STAND	1				
16	T360715000	MOTOBOMBA 5213E2450 FIR 50Hz	MOTOR-PUMP 5213E2450 FIR	1				

MOD.	HORNOS / OVEN	ZONA / ZONE	CONDUCCIONES DE AGUA / WATER PIPE
------	---------------	-------------	-----------------------------------

ITEM	CODIGO CODE	DENOMINACION	NAME	VPG-102				
17	T330731000	GOMA VALVULA BOMBA	PUMP VALVE RUBBER	1				
	Q881304000	ABRAZADERA 20-32	CLAMP 20-32	1				
	Q881305000	ABRAZADERA 25-40	CLAMP 25-40	1				
18	T330707000	PUNTA ACOPLE MOTOR A VALV.	CONN. POINT MOTOR TO VAL.	1				
S/Nº	Q307084000	JUNTA TORICA Ø11X3.5	O-RING Ø18X3.5	1				
S/Nº	12019645	JUNTA TORICA Ø10x3.5	O-RING Ø10X3.5	1				
19	T330723000	CUERPO VALVULA COMPLETO	COMPLETE VALVE BODY	1				
	T330703000	JUNTA TEFLON VALVULA	TEFLON VALVE BOARD	2				
	T330703000	JUNTA TEFLON VALVULA	TEFLON VALVE BOARD	1				
	T330749000	JUNTA TEFLON VALVULA	TEFLON VALVE BOARD	1				
	Q307080000	JUNTA TORICA Ø52X3,5	O-RING Ø52X3.5	1				
	Q307079000	JUNTA TORICA Ø33x3,5	O-RING Ø33x3.5	1				
S/Nº	Z200910000	MANGUERA DESAGUE	DRAIN HOSE	1				
20	3716000000	TUBO SILICONA Tº Ø 35*27	HIGH SILICON PIPE Tº Ø 35*27	1				
	Q881305000	ABRAZADERA 25-40	CLAMP 25-40	2				

Зип Общепит

vsezip.ru

+7(812)987-08-81

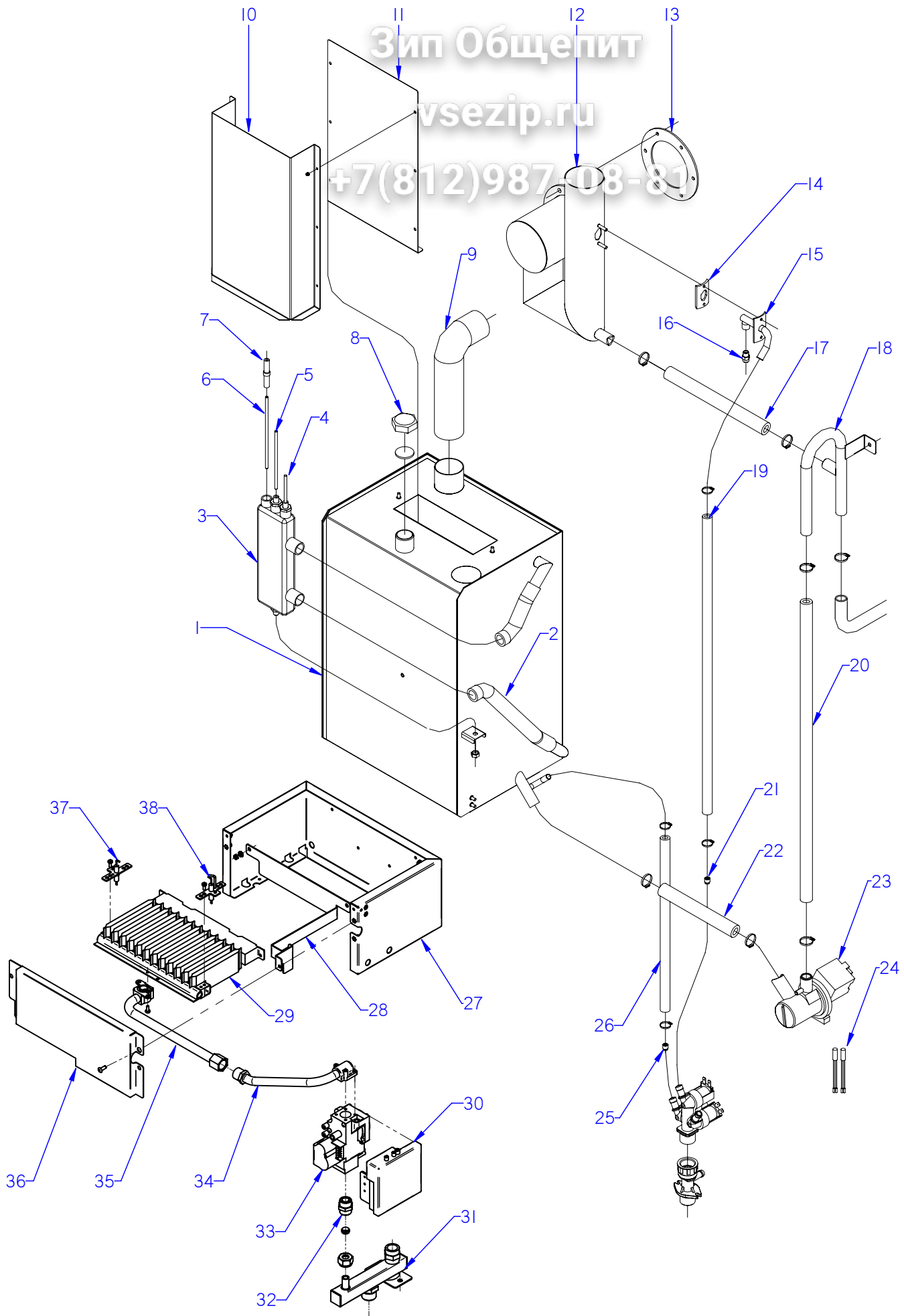

ITEM MARCADO EN COLOR = REPUESTO RECOMENDADO
COLOURED ITEM = RECOMMENDED SPARE PART

N plano	Firma	Fecha	Aparato	CIRCUITO DE VAPOR / STEAM CIRCUIT	Lamina	Fagor Industrial S.Coop. FAGOR
C-2772	<i>(Signature)</i>	2010-12	HORNO VG-201 / VPG-201		9	Oñate

MOD.	HORNOS / OVEN	ZONA / ZONE	CIRCUITO DE VAPOR / STEAM CIRCUIT					
ITEM	CODIGO CODE	DENOMINACION	NAME	VG-102	VPG-102			
1		KIT GENERADOR DE VAPOR 102	STEAM GENERATOR KIT 102	1	1			
1	T645003000	GENERADOR DE VAPOR	STEAM GENERATOR	1	1			
S/Nº	Z956104000	INYECTOR 1.1 A-15009 GN	1.1 A-15 009 INJECTOR GN	12	12			
S/Nº	Z950353000	ESCUADRA PROTECCION	BRACKET PROTECTION	2	2			
	Q242030000	ARANDELA ABANICO A5 A.304	FAN WASHER A5 A.304	4	4			
	Q163030000	TUERCA EXAGONAL M5	HEXAGONAL NUT M5	4	4			
2	3715900000	TUBO SILICONA ALTA Tª Ø26*18	HIGH SILICON PIPE Tª Ø26*18	2	2			
	Q901312000	ABRAZADERA ELASTI. Ø50,6-53,2	ELAST. CLAMP Ø50,6-53,2	4	4			
3	T325079000	BOTE DE NIVELES	LEVELS VESSEL	1	1			
	Q228051000	TUERCA EXAGONAL M8 PLASTICO	HEXAGONAL NUT M8 PLASTIC	1	1			
4	R345063000	ELECTRODO DE NIVEL BAJO	LOW LEVEL ELECTRODE	1	1			
5	R345060000	ELECTRODO DE NIVEL ALTO	HIGH LEVEL ELECTRODE	1	1			
6	R345064000	ELECTRODO DE MASA	EARTH ELECTRODE	1	1			
7	R345069000	GUIA AISLANTE	INSULATION GUIDE	3	3			
8	R015010000	TUERCA TAPON 1"	PLUG NUT 1"	1	1			
	R015011000	ARANDELA Ø32	WASHER Ø32	1	1			
9	T722608000	TUBO FLEXIBLE Ø53X360	FLEXIBLE TUBE Ø53X360	1	1			
9	12041855	TUBO FLEXIBLE Ø53x360 VARIL INO	FLEXIBLE TUBE ROD Ø53x360 IN	1	1			
	Q881307000	ABRAZADERA 40*60	CLAMP 40*60	2	2			
10	T302636000	ANTER. CHIMENEA GENERADOR	FRONT FLUEPIPE GENERATOR	1	1			
	Q412002000	REMACHE TUBULAR Ø4x7,5	TUBULAR RIVET Ø4x7.5	12	12			
11	T302637000	POSTER. CHIMENEA GENERADOR	REAR FLUEPIPE GENERATOR	1	1			
12	T305026000	RETORNO COMPLETO 10/21	COMPLETE RETURN 10/21	1	1			
	Q262040000	ARANDELA GROWER A6	WASHER GROWER A6	6	6			
	Q162040000	TUERCA EXAGONAL M6	HEXAGONAL NUT M6	6	6			
13	T305043000	JUNTA COLECTOR	COLLECTOR SEAL	1	1			
14	R725159000	JUNTA TUBO INYECTOR	INJECTOR PIPE SEAL	1	1			
15	T115112000	CONDUCCION DE VAHOS COMPL.	COMPL. VAPOUR DUCT	1	1			
16	T115086000	TOBERA 1/8"	NOZZLE 1/8	1	1			
	Q242030000	ARANDELA ABANICO A5 A.304	FAN WASHER A5 A.304	2	2			
	Q162030000	TUERCA EXAGONAL M5	HEXAGONAL NUT M5	2	2			

MOD.	HORNOS / OVEN	ZONA / ZONE	CIRCUITO DE VAPOR / STEAM CIRCUIT					
ITEM	CODIGO CODE	DENOMINACION	NAME	VG-102	VPG-102			
17	3715900000	TUBO SILICONA ALTA Tª Ø26*18	HIGH SILICON PIPE Tª Ø26*18	1	1			
	Q901311000	ABRAZADERA ELASTI. Ø26,7-28,1	ELAST. CLAMP Ø26.7-28.1	2	2			
18	T305019000	CONduc. DESAGÜE GENERADOR	GENERATOR DRAIN PIPE	1	1			
	Q221342000	REMACHE EXAGONAL M5	HEXAGONAL RIVET M5	1	1			
	Q242030000	ARANDELA ABANICO A5	FAN WASHER A5	1	1			
	Q012031000	TORNILLO EXAGONAL M5x10	HEXAGONAL BOLT M5x10	1	1			
19	3676900000	TUBO GOMA NEGRA Ø17xØ10	BLACK RUBBER PIPE Ø17*10	1	1			
	Q901310000	ABRAZADERA ELASTI. Ø16,8-17,7	ELAST. CLAMP Ø16.8-17.7	2	2			
20	3715900000	TUBO SILICONA ALTA Tª Ø26*18	HIGH SILICON PIPE Tª Ø26*18	1	1			
	Q901311000	ABRAZADERA ELASTI. Ø26,7-28,1	ELAST. CLAMP Ø26.7-28.1	2	2			
21	P443042000	REGULADOR 3L VERDE 254.023	REGULATOR 3L GREEN 254.023	1	1			
22	3715900000	TUBO SILICONA ALTA Tª Ø26*18	HIGH SILICON PIPE Tª Ø26*18	1	1			
	Q901311000	ABRAZADERA ELASTI. Ø26,7-28,1	ELAST. CLAMP Ø26.7-28.1	2	2			
23	Z220901000	BOMBA DESAGUE 30W	DRAINAGE PUMP 30W	1	1			
23	Z223501000	BOMBA DE DESAGUE 30W 60HZ	DRAINAGE PUMP 30W 60HZ	1	1			
24	Z233012000	CONDENSAD. ANTIPARASITARIO	ANTIPARASITIC CONDENSER	1	1			
25	Z601156000	REGULADOR 8L RO. 254.034	REGULATOR 8L RED 254.034	1	1			
26	3676900000	TUBO GOMA NEGRA Ø17xØ10	BLACK RUBBER PIPE Ø17*10	1	1			
	Q901310000	ABRAZADERA ELASTI. Ø16,8-17,7	ELAST. CLAMP Ø16.8-17.7	2	2			
27	T305704000	CAJA QUEMADOR	BURNER BOX	1	1			
28	T305706000	ESCUADRA AMARRE QUEMADOR	TIE BRACKET BURNER	1	1			
29	Z955801000	QUEMADOR F0000161	BURNER F0000161	1	1			
	Q032021000	TORNILLO ALOMADO M4X10	CURVED SCREW M4X10	2	2			
	Q242020000	ARANDELA ABANICO A4	FAN WASHER A4	2	2			
	Q162020000	TUERCA EXAGONAL M4	HEXAGONAL NUT M4	2	2			
30	T303013000	CONTROL DE ENCENDIDO HONEYWELL	IGNITION CONTROL HONEYWELL	1	1			
31	T305093000	ENTRADA GAS COMPLETA	COMPLETE GAS INPUT	1	1			
	Q232030000	ARANDELA A5	WASHER A5	2	2			
	Q242030000	ARANDELA ABANICO A5 A.304	FAN WASHER A5 A.304	2	2			
	Q012032000	TORNILLO EXAGONAL M5x15	HEXAGONAL BOLT M5x15	2	2			

Зип Общепит

MOD.	HORNOS / OVEN	ZONA / ZONE	CIRCUITO DE VAPOR / STEAM CIRCUIT
------	---------------	-------------	-----------------------------------

ITEM	CODIGO CODE	DENOMINACION	NAME	VG-102	VPG-102				
32	S205023000	MANGUITO DOBLE 1/2	DOUBLE SLEEVE 1/2	1	1				
	Q221334000	TUERCA 1/2"	NUT 1/2"	1	1				
	U055043000	BICONO Ø12	BICONE Ø12	1	1				
33	T305054000	VALVULA VK 4105T	VALVE VK 4105T	1	1				
34	T305090000	TUBO DE GAS FLEXIBLE 300-90º	FLEXIBLE GAS PIPE 300-90 °	1	1				
35	T305718500	ACOPLADOR COMPL. PINTADO	PAINTED COMPL. COUPLER	1	1				
	Z955807000	JUNTA CORCHO	CORK SEAL	1	1				
	T305705000	TAPA CAJA	BOX COVER	1	1				
37	Z955803000	ELECTRODO DETECCION F1643600	DETECTION ELECTRODE F1643600	1	1				
	Q151320000	TOR. ALOMADO M4X6 H. ZINCADO	CURVED SCREW M4X6 H. ZINC-C	1	1				
38	Z955802000	ELECTRODO IGNICION F1643500	IGNITION ELECTRODE F1643500	1	1				
	Q151320000	TOR. ALOMADO M4X6 H. ZINCADO	CURVED SCREW M4X6 H. ZINC-C	1	1				

Зип Общепит

vsezip.ru

+7(812)987-08-81

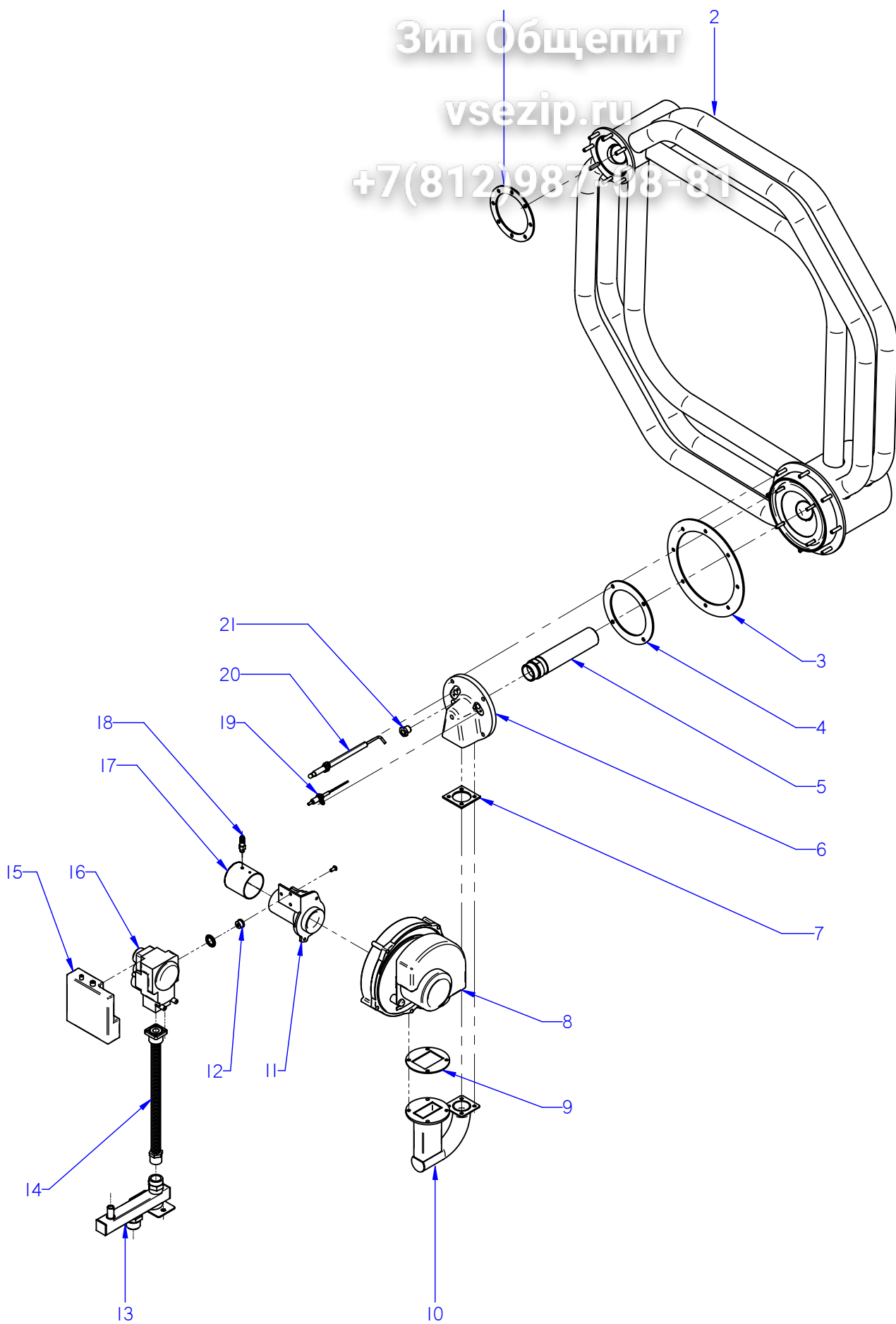

ITEM MARCADO EN COLOR = REPUESTO RECOMENDADO
COLOURED ITEM = RECOMMENDED SPARE PART

N plano	Firma	Fecha	Aparato	PARTE FUNCIONAL GAS / FUNCTIONAL PART GAS	Lamina	Fagor Industrial S.Coop. FAGOR
C-2773	<i>(Signature)</i>	2010-12	HORNO COG / VG / VPG-102		10	Oñate

MOD.		HORNOS / OVEN		ZONA / ZONE		PARTE FUNCIONAL GAS FUNCTIONAL PART GAS		
ITEM	CODIGO CODE	DENOMINACION	NAME	COG-102	VG-102	VPG-102		
1	T305043000	JUNTA COLECTOR	COLLECTOR SEAL	—	1	1		
2	T345701000	CAMARA COMBUSTION	COMBUSTION CHAMBER	1	—	—		
2	T365701000	INTERCAMBIADOR HGP	HEAT EXCHANGER HGP	—	1	1		
	Q232040000	ARANDELA A6	WASHER A6	8	8	8		
	Q262040000	ARAND.GROW. A6 A.304	WASHER GROW. A6 A.304	8	8	8		
	Q163040000	TUER.EXA.M6 LATON	HEX NUTM6 BRASS	8	8	8		
3	R725051000	JUNTA CAMARA COMBUST.	FUEL CHAMBER SEAL	1	1	1		
4	R725055000	JUNTA DE TAPA PRINCIPAL	MAIN COVER SEAL	1	1	1		
5	T115710000	QUEMADOR FURIGAS 10-11/10-21	BURNER 10-11/10-21	1	1	1		
6	T115782000	TAPA PRINCIPAL	PRINCIPAL COVER	1	1	1		
	Q232030000	ARANDELA A5	WASHER A5	4	4	4		
	Q242030000	ARAND.GROW. A5 A.304	WASHER GROW A5 A.304	4	4	4		
	Q163030000	TUER.EXA.M5 LATON	HEX NUTM5 BRASS	4	4	4		
7	T305041000	JUNTA TAPA PRINCIPAL	PRINCIPAL COVER SEAL	1	1	1		
8	T303016000	VENTILADOR RG-130	VALVE FAN RG-130	1	1	1		
9	T305042000	JUNTA VENTILADOR	FAN SEAL	1	1	1		
	Q242030000	ARANDELA ABANICO A5 A.304	FAN WASHER A5 A.304	8	8	8		
	Q012032000	TORNILLO EXAGONAL M5x15	HEXAGONAL BOLT M5x15	8	8	8		
	Q232030000	ARANDELA A5	WASHER A5	12	12	12		
	Q162030000	TUERCA EXAGONAL M5	HEXAGONAL NUT M5	4	4	4		
10	T345000000	CONDUCTO TAPA PRINCIPAL	PRINCIPAL COVER PIPE	1	—	—		
10	T305035000	CONDUCTO TAPA PRINCIPAL	PRINCIPAL COVER PIPE	—	1	1		
11	T303040000	VENTURI 45.900.446.052	VENTURI 45.900.446.052	1	1	1		
	Q032031000	TORNILLO ALOMADO M5X10	CURVED SCREW M5X10	3	3	3		
12	T305068000	TOBERA VK41 Ø 4.8 BP	NOZZLE VK41 Ø 4.8 BP	1	1	1		
12	T305069000	TOBERA VK41 Ø 6 GN	NOZZLE VK41 Ø 6 GN	1	1	1		
S/Nº	T303046000	JUNTA VENTURI 24x15.5	VENTURI SEAL	1	1	1		
13	T345021000	ENTRADA GAS COMPLETA	COMPLETE GAS INPUT	1	—	—		
13	T305093000	ENTRADA GAS COMPLETA	COMPLETE GAS INPUT	—	1	1		
	Q242030000	ARANDELA ABANICO A5 A.304	FAN WASHER A5 A.304	2	2	2		
	Q012032000	TORNILLO EXAGONAL M5x15	HEXAGONAL BOLT M5x15	2	2	2		

MOD.	HORNOS / OVEN	ZONA / ZONE	PARTE FUNCIONAL GAS FUNCTIONAL PART GAS				
------	----------------------	--------------------	--	--	--	--	--

ITEM	CODIGO CODE	DENOMINACION	NAME	COG-102	VG-102	VPG-102		
14	T305091000	TUBO DE GAS FLEXIBLE 850	FLEXIBLE GAS PIPE 850	1				
14	T305089000	TUBO DE GAS FLEXIBLE 300	FLEXIBLE GAS PIPE 300		1	1		
15	T303013000	CONTROL DE ENCENDIDO HONEYW	IGNITION CONTROL HONEYWEL	1	1	1		
16	T303017000	VALVULA VK 4115 V 1121	VALVE VK 4115 V 1121	1	1	1		
17	T305712000	TUBO VENTILADOR COMPLETO	COMPLETE FAN PIPE	1	1	1		
18	R725077000	BOQUILLA CONEXION PRESOST.	NOZZLE PRESSURE CONNECT.	1	1	1		
19	T115712000	ELECTROD DETEC 6/101/102 GAS	DETEC. ELECTRODE 6/101/102	1	1	1		
	Q153021000	TORNILLO ALOMADO M4 X 10	CURVED SCREW M4 X 10	3	3	3		
20	T115781000	ELECTRODO IGNICION 10/11-10/	IGNITION ELECTRODE 10/11-10/	1	1	1		
21	R725015000	VISOR DE ENCENDIDO	IGNITION WINDOW	1	1	1		
	R725063000	CRISTAL DE VISOR	WINDOW GLASS	1	1	1		

Зип Общепит

vsezip.ru

+7(812)987-08-81

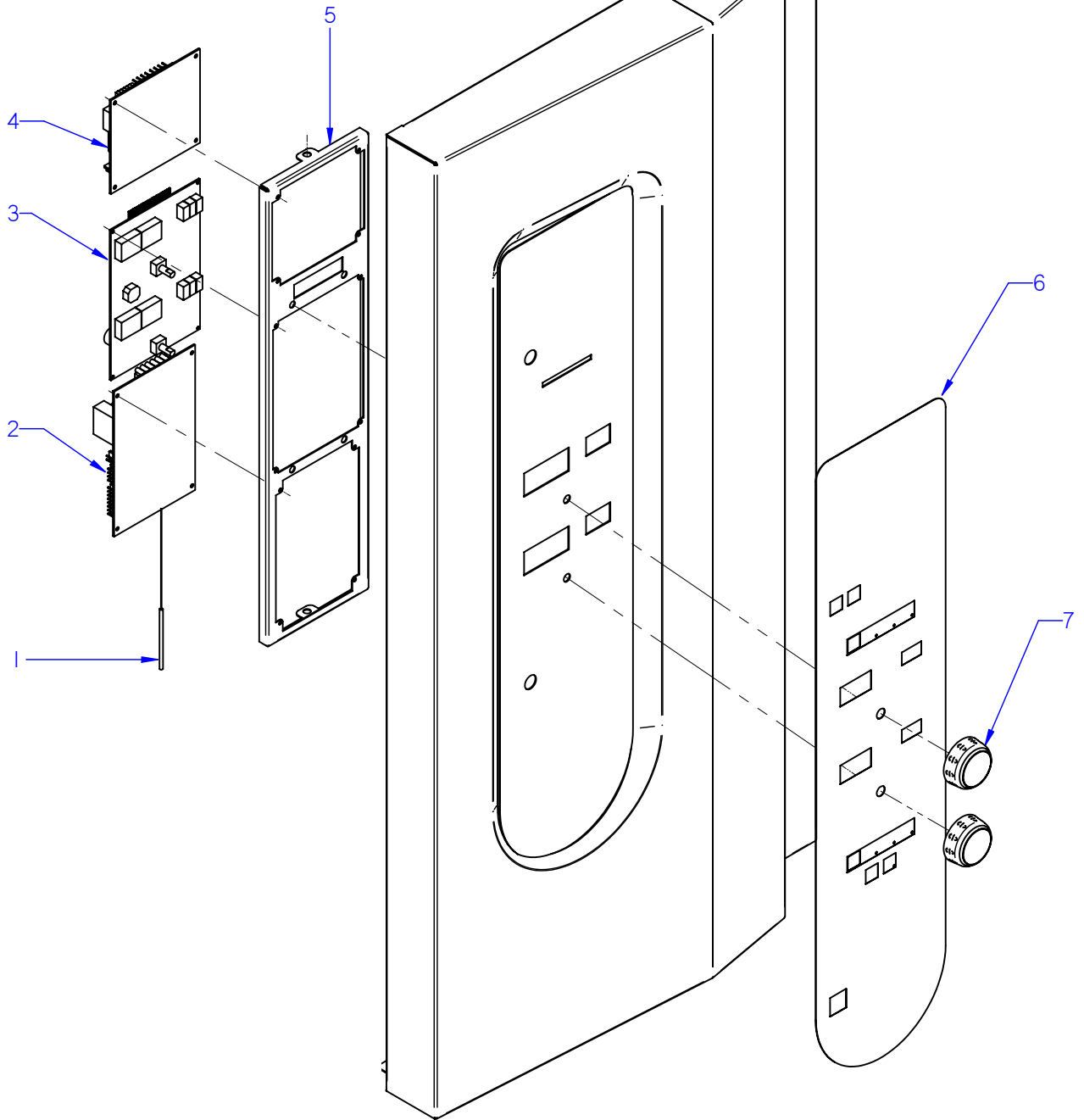

ITEM MARCADO EN COLOR = REPUESTO RECOMENDADO
COLOURED ITEM = RECOMMENDED SPARE PART

N plano	Firma	Fecha	Aparato	CONJUNTO ELECTRICO PORTAMANDOS / CONTROL HOLDER ELECTRIC	Lamina	Fagor Industrial S.Coop. FAGOR
C-2774	<i>(Signature)</i>	2012-10	HORNOS COG-102		11	Oñate

+7(812)987-08-01

APARATO / APPLIANCE		HORNOS / OVENS		ZONA / ZONE		CONJUNTO ELECTRICO PORTAMANDOS CONTROL HOLDER ELECTRIC UNIT								
ITEM	CODIGO REFERENCE	DENOMINACION	DENOMINATION	COG-12										
1	T323011000	CONJUN. TERMOPAR CAMARA (K)	CHAMBER THERMOCOUPLE UNI	1										
2	T553003000	TARJETA CONTROL DE CAMARA	CHAMBER CONTROL CARD	1										
2	12097540	CONTROL TARJETA CAM.12V AC .	CARD CONTROL 12V AC 50/60Hz	1										
	Q221026000	CLIP SUJECIÓN RÁPIDA Ø 4	RAPID CONNE RAPID RAPID RA	4										
3	T533001000	TARJETA PORTAMANDOS HEI-HG	CONTROL PANEL CARD	1										
3	12097547	VISUALIZADOR 12V AC 50/60Hz 12	12V AC 50/60Hz 12D DISPLAY	1										
	Q221026000	CLIP SUJECIÓN RÁPIDA Ø 4	RAPID CONNE RAPID RAPID RA	4										
4	T553004000	TARJETA CONTROL DE GAS	CONTROL CARD GAS	1										
	Q221026000	CLIP SUJECIÓN RÁPIDA Ø 4	RAPID CONNE RAPID RAPID RA	4										
5	T932802000	SOPORTE PROGRAMADOR	PROGRAM. SUPPORT	1										
6	T633001000	SERIGRAFIA HEM 21	SERIGRAPHY HEM 21	1										
7	T903007000	BOTON DE MANDO	CONTROL BUTTON	2										

Зип Общепит

vsezip.ru

+7(812)987-08-81

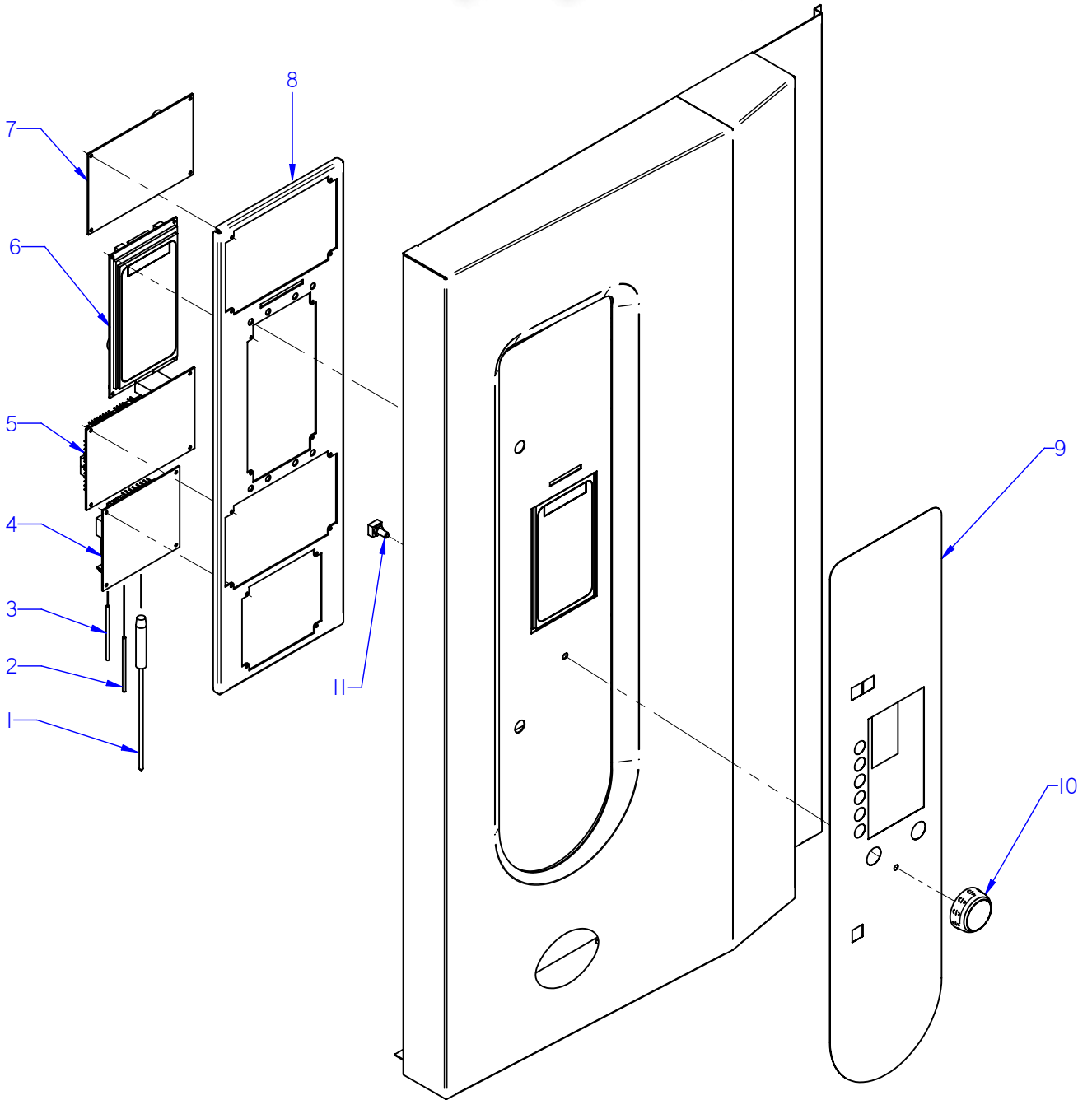

ITEM MARCADO EN COLOR = REPUESTO RECOMENDADO
COLOURED ITEM = RECOMMENDED SPARE PART

N plano	Firma	Fecha	Aparato	CONJUNTO ELECTRICO PORTAMANDOS / CONTROL HOLDER ELECTRIC	Lamina	Fagor Industrial S.Coop. FAGOR
C-2775	<i>(Signature)</i>	2010-12		HORNOS VG-102	12	Oñate

APARATO / APPLIANCE		HORNOS / OVENS		ZONA / ZONE		CONJUNTO ELECTRICO PORTAMANDOS CONTROL HOLDER ELECTRIC UNIT							
ITEM	CODIGO REFERENCE	DENOMINACION	DENOMINATION	VG-102									
1	T303007000	CONJUNTO Sonda para Nucleo	PROBE UNIT FOR CORE	1									
2	T323011000	CONJUN. TERMOPAR CAMARA (K)	CHAMBER THERMOCOUPLE UNI	1									
3	T323024000	CONJUN. TERMOPAR VAPOR 10/2	STEAM THERMOCOUPLE UNIT 1	1									
4	T553004000	TARJETA CONTROL DE GAS	CONTROL CARD GAS	1									
	Q221026000	CLIP SUJECIÓN RÁPIDA Ø 4	RAPID CONNE RAPID RAPID RAP	4									
5	T553003000	TARJETA CONTROL DE CAMARA	CHAMBER CONTROL CARD	1									
5	12097540	CONTROL TARJETA CAM.12V AC .	CARD CONTROL 12V AC 50/60Hz	1									
	Q221026000	CLIP SUJECIÓN RÁPIDA Ø 4	RAPID CONNE RAPID RAPID RAP	4									
6	T913003000	CIRC PORTAMANDOS HEM HGV	CONTROL HOLDER CIRCUIT HE	1									
6	12046658	VISUALIZADOR 12V AC 50/60Hz 32	12V AC 50/60Hz 32 D DISPLAY	1									
	Q221026000	CLIP SUJECIÓN RÁPIDA Ø 4	RAPID CONNE RAPID RAPID RAP	4									
7	T553002000	TARJETA CONTROL CALDERA	BOILER CONTROL CARD	1									
7	12097545	CONTROL TARJETA CALD. 12V AC	CARD CONTROL 12V AC 50/60Hz	1									
	Q221026000	CLIP SUJECIÓN RÁPIDA Ø 4	RAPID CONNE RAPID RAPID RAP	4									
8	T842812000	SOPORTE CIRCUITOS HGV 10-11	SUPPORT CIRCUITS HGV 10-11	1									
	Q232030000	ARANDELA A5	WASHER A.5	4									
	Q221308000	TUE.EX.AUT.M5 H.ZINCADA	HEXAGONAL NUT M5 H. ZINC,	4									
	Q412005000	REMACHE AVINOX Ø3x2,6MM	TUBULAR RIVET Ø3x2,6MM	15									
9	T613006000	SERIGRAFIA HEM 21	SERIGRAPHY HEM 21	1									
10	T903007000	BOTON DE MANDO	CONTROL BUTTON	1									
11	T513009000	ENCODER GAMA VISUAL	VISUAL RANGE ENCODER	1									

Зип Общепит

vsezip.ru

+7(812)987-08-81

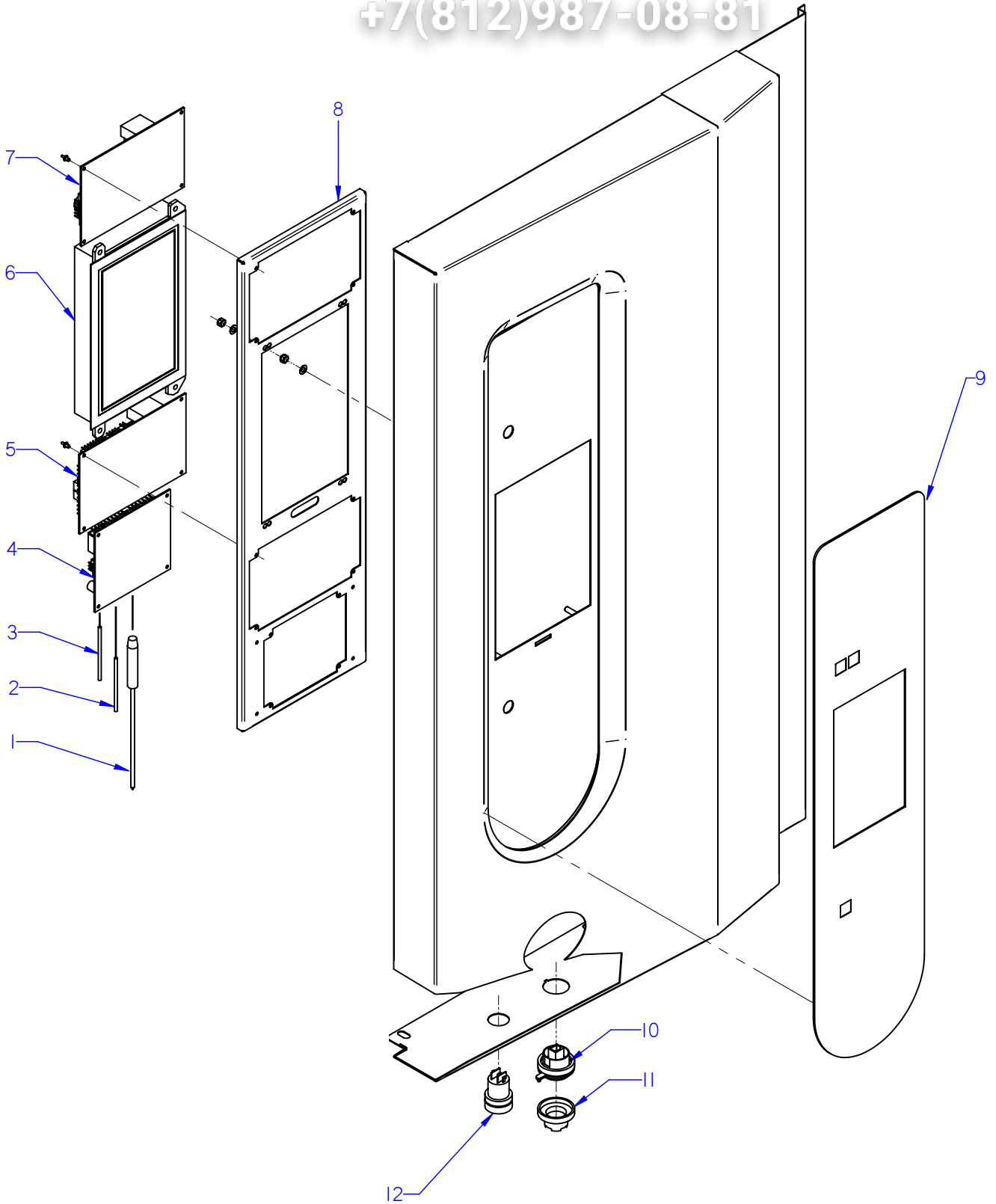

ITEM MARCADO EN COLOR = REPUESTO RECOMENDADO
COLOURED ITEM = RECOMMENDED SPARE PART

N plano	Firma	Fecha	Aparato	CONJUNTO ELECTRICO PORTAMANDOS / CONTROL HOLDER ELECTRIC	Lamina	Fagor Industrial S.Coop. FAGOR
C-2776	<i>(Signature)</i>	2010-12	HORNOS VPG-102		13	Oñate

APARATO / APPLIANCE		HORNOS / OVENS		ZONA / ZONE		CONJUNTO ELECTRICO PORTAMANDOS CONTROL HOLDER ELECTRIC UNIT					
ITEM	CODIGO REFERENCE	DENOMINACION	DENOMINATION	VPG-102							
1	T623006000	CONJUN. Sonda NUCLEO 5 PUNT	PROBE UNIT FOR CORE	1							
2	T323011000	CONJUN. TERMOPAR CAMARA (K)	CHAMBER THERMOCOUPLE UNI	1							
3	T323024000	CONJUN. TERMOPAR VAPOR 10/2	STEAM THERMOCOUPLE UNIT 1	1							
4	T553004000	TARJETA CONTROL DE GAS	CONTROL CARD GAS	1							
	Q221026000	CLIP SUJECIÓN RÁPIDA Ø 4	RAPID CONNE RAPID RAPID RAP	4							
5	T553003000	TARJETA CONTROL DE CAMARA	CHAMBER CONTROL CARD	1							
5	12097540	CONTROL TARJETA CAM.12V AC .	CARD CONTROL 12V AC 50/60Hz	1							
	Q221026000	CLIP SUJECIÓN RÁPIDA Ø 4	RAPID CONNE RAPID RAPID RAP	4							
6	T553010000	PLATAFORMA VISUAL PLUS	VISUAL PLUS PLATFORM	1							
	Q032011000	TORNILLO ALOMADO M3x10	CURVED SCREW M.3x10	4							
	Q232010000	ARANDELA PLANA A3 DIN 125	WASHER A3 DIN 125	4							
	Q242010000	ARANDELA ABANICO A3 A.304	FAN SHAPED WASHER A.3	4							
	Q161310000	TUERCA EXAGONAL M3 H. ZINC,	HEXAGONAL NUT M3 H. ZINC,	4							
	Q221026000	CLIP SUJECIÓN RAPIDA Ø 4	RAPID CONNE RAPID RAPID RAP	4							
7	T553002000	TARJETA CONTROL CALDERA	BOILER CONTROL CARD	1							
7	12097545	CONTROL TARJETA CALD. 12V AC	CARD CONTROL 12V AC 50/60Hz	1							
	Q221026000	CLIP SUJECIÓN RAPIDA Ø 4	RAPID CONNE RAPID RAPID RAP	4							
8	T652804000	SOPORTE CIRCUITOS VPE VPG 21	SUPPORT CIRCUITS VPE VPG 21	1							
	Q232030000	ARANDELA A5	WASHER A.5	4							
	Q221308000	TUE.EX.AUT.M5 H.ZINCADA	HEXAGONAL NUT M5 H. ZINC,	4							
	Q412005000	REMACHE AVINOX Ø3x2,6MM	TUBULAR RIVET Ø3x2,6MM	15							
9	T623016000	SERIGRAFIA VISUAL PLUS 8" 16	SERIGRAPHY VISUAL PLUS 8" 16	1							
10	T723006000	CONECTOR USB VISUAL PLUS	VISUAL PLUS USB CONNECTOR	1							
11	T723007000	TAPA USB VISUAL PLUS	VISUAL PLUS USB COVER	1							
12	T723009000	PULSADOR SERIE MICRO	MICRO SWITCH SERIES	1							

Зип Общепит

vsezip.ru

+7(812)987-08-81

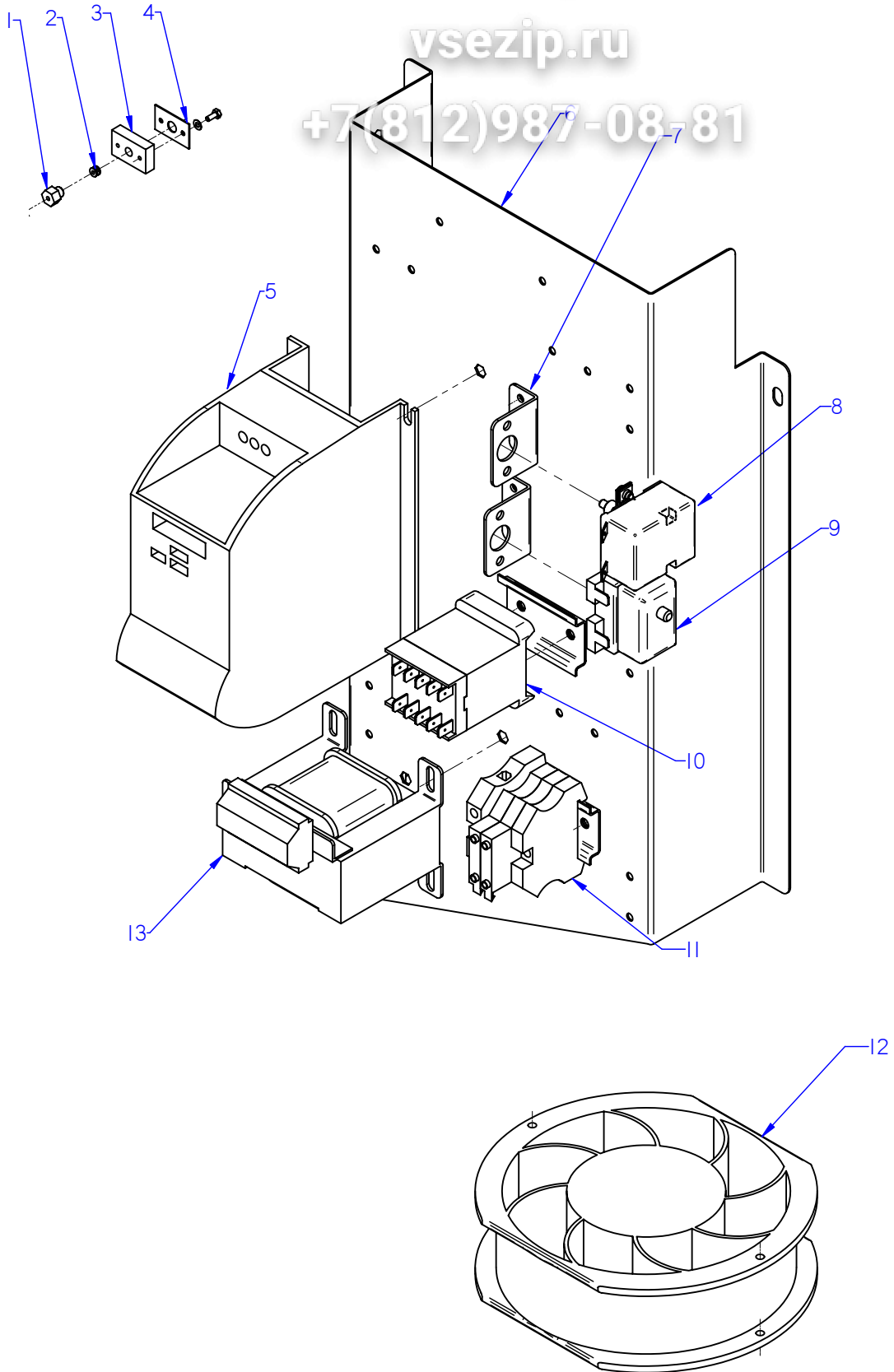

ITEM MARCADO EN COLOR = REPUESTO RECOMENDADO
COLOURED ITEM = RECOMMENDED SPARE PART

N plano	Firma	Fecha	Aparato	Lamina	Fagor Industrial S.Coop. FAGOR
C-2777	<i>(Signature)</i>	2010-12	CUADRO ELECTRICO / ELECTRIC PANEL HORNOS COG / VG / VPG-102	14	Oñate

MOD.		HORNOS / OVEN	ZONA / ZONE	CUADRO ELECTRICO / ELECTRIC PANEL			
ITEM	CODIGO CODE	DENOMINACION	NAME	COG-102	VG-102	VPG-102	
1	R662629000	RACORD CIERRE SONDA	PROBE CLOSING ADAPTOR	2	2	2	
S/Nº	R662662000	JUNTA CIERRE BULBO LIMITADOR	BULB LIMITER CLOSING SEAL	1	1	1	
2	R662652000	BICONO CIERRE SONDA	PROBE CLOSING BICONE	1	1	1	
3	T112625000	BASE CIERRE SONDA	FIXING CORE PROBE	2	2	2	
4	R692812000	JUNTA PASAMUROS SIMPLE	SIMPLE FEEDTHROUGH SEAL	2	2	2	
	Q232020000	ARANDELA A4	WASHER A.4	4	4	4	
	Q012021000	TORNILLO EXAGONAL M4X10	HEXAGONAL SCREW M.4X10	4	4	4	
5	T323037000	VARIADOR FRECUENCIA SIE 0,37	FREQUENCY VARIATOR SIE 0.37	1	1	1	
	Q232020000	ARANDELA A4	WASHER A.5	2	2	2	
	Q242020000	ARANDELA ABANICO A4 A.304	FAN SHAPED WASHER A.4	2	2	2	
	Q032021000	TORNILLO ALOMADO M4X10	CURVED SCREW M.4x10	2	2	2	
6	T633003000	CHAPA CUADRO ELEC VG-P 102	SQUARE PLATE ELEC VG-P102	1	1	1	
	Q221341000	REMACHE EXAGONAL M4	HEXAGONAL RIVET M.4	8	8	8	
	Q232030000	ARANDELA A5	WASHER A.5	2	2	2	
	Q242030000	ARANDELA ABANICO A5 A.304	FAN SHAPED WASHER A.5	2	2	2	
	Q012032000	TORNILLO EXAGONAL M5x15A304	HEXAGONAL SCREW M.5x15	2	2	2	
	Q232040000	ARANDELA A6	WASHER A.6	1	1	1	
	Q242040000	ARANDELA ABANICO A6 A.304	FAN SHAPED WASHER A.6	1	1	1	
	Q162040000	TUERCA EXAGONAL M6	HEXAGONAL NUT M.6	1	1	1	
7	R343039000	SOPORTE TERMOS VAPOR	THERMOSTAT SUPPORT	1	2	2	
	Q412002000	REMACHE AVINOX Ø4x10MM	TUBULAR RIVET 4x7,5	2	4	4	
8	T303009000	TERMOSTATO LIMITADOR	THERMOSTAT LIMITER	1	1	1	
9	Z953035000	TERMOSTATO LIMITADOR AVISO	LIMITER THERMOSTAT WARNIN	1	1	1	
	Z953041000	TUERCA M.10x1 EGO 00.00600.075	NUT M.10x1 EGO 00.00600.075	2	2	2	
10	Z213007000	CONTACTOR 230V.50-60	230V.50-60 CONTACTOR	1	1	1	
11	P453026000	BORNE TIER 10 WPE-10103.O	10 WPE-10103.O EARTH TERM.	1	1	1	
	R073005000	BORNA PORTAFUSIBLES	FUSE HOLDER TERMINAL	1	1	2	
	Z263303000	TOPE FINAL	END BUFFER	1	1	1	

MOD.	HORNOS / OVEN	ZONA / ZONE	CUADRO ELECTRICO / ELECTRIC PANEL
------	---------------	-------------	-----------------------------------

ITEM	CODIGO CODE	DENOMINACION	NAME	COG-102	VG-102	VPG-102		
12	Z103066000	VENTILADOR 230V.50-60HZ	FAN 230V 50/60HZ	2				
12	T453005000	VENTILADOR 230V.20/21	FAN 230V 20/21		2	2		
	Q031322000	TORNILLO ALOMADO M4x15	CURVED SCREW M.4x15	4	4	4		
	Q232020000	ARANDELA A4	WASHER A.4	4	4	4		
	Q242020000	ARANDELA ABANICO A4 A.304	FAN SHAPED WASHER A.4	4	4	4		
	Q162020000	TUERCA EXAGONAL M4	HEXAGONAL NUT M.4	4	4	4		
S/Nº	T113015000	PROTECCION VENTILADOR	FAN PROTECTION	1				
	Q418022000	REMACHE NYLON 4x15	TUBULAR RIVET NYLON 4x15	4				
13	R503005000	TRANSFORMADOR 230/14-0-12,0-1	TRANSFORMER 230/14-0-12,0-1	1	1			
13	T853002000	TRANSFORMADOR 12-0-12-0,24-0	TRANSFORMER 12-0-12-0,24-0			1		
	Q232020000	ARANDELA A4	WASHER A.5	4	4	4		
	Q242020000	ARANDELA ABANICO A4 A.304	FAN SHAPED WASHER A.4	4	4	4		
	Q032021000	TORNILLO ALOMADO M4X10	CURVED SCREW M.4x10	4	4	4		

MOD.		HORNOS / OVEN	ZONA / ZONE	VARIOS / MISCELLANEOUS			
ITEM	CODIGO CODE	DENOMINACION	NAME	COG-102	VG-102	VPG-102	
	T936501000	MANUAL DE INSTRUCCION. COG	INSTRUCTIO. BROCHURE COG	1	-	-	
	T946501000	MANUAL DE INSTRUCCION. VG	INSTRUCTIO. BROCHURE VG	-	1	-	
	T956501000	MANUAL DE INSTRUCCION. VPG	INSTRUCTIO. BROCHURE VPG	-	-	1	
	T643005000	ESQUEMA TEORICO GAS 102-202	THE. DIAGRAM GAS 102-202	1	1	1	
	T633006000	PLANO MONTAJE COG	ASSEMBLY PLAN COG	1	-	-	
	T643006000	PLANO MONTAJE VG-202 VPG-202	ASSEMBLY PLAN VG-202 VPG-202	-	1	1	
	T303042000	LEYENDA HORNOS	LEGEND OVENS	1	1	1	
	T633004000	INSTAL. ELECTRICA 201	201VG 102	1	-	-	
	T643007000	INSTAL. ELECTRICA VG 102	ELEC. INSTALL. VG 102	-	1	1	
	T303031000	CABLEADO LUZ INTERIOR HVG10-	INTERIOR LIGHT WIRING HVG10-	1	1	1	
	T333009000	CABLEADO LAVADO HEP	WASH WIRING HEP	-	-	1	
	T853003000	CABLEADO TRANSFORMA. - TFT	TRANSFORMER WIRING - TFT	-	-	1	
	T723008000	CABLE USB VISUAL PLUS	VISUAL PLUS USB CABLE	-	-	1	
	T303058000	CABL. VARIADOR SOPL.HGV10-21	VARIATOR WIRING SOPL.HGV10-	1	1	1	
	T303034000	CABLE ENCENDIDO CAMARA 102	ON CAMERA WIRING 102	1	1	1	
	T303035000	CABLE DETEC LLAMA CAMARA 102	10220-21	1	1	1	
	T303036000	CABLE ENCENDIDO CALDERA 10-2	ON BOILER WIRING 20-21	-	1	1	
	T303037000	CABLE DETECT LLAMA CALD.102	FLAME BOILER WIRING 102	-	1	1	
	T923016000	CABLEADO BMF	WIRING BMF	2	3	3	
	T523004000	CABLEADO PULSADOR RESET	RESET BUTTON WIRING	-	-	1	

VPG 10 2,
VG 10 2
COG 10 2

+7(812)987-08-81

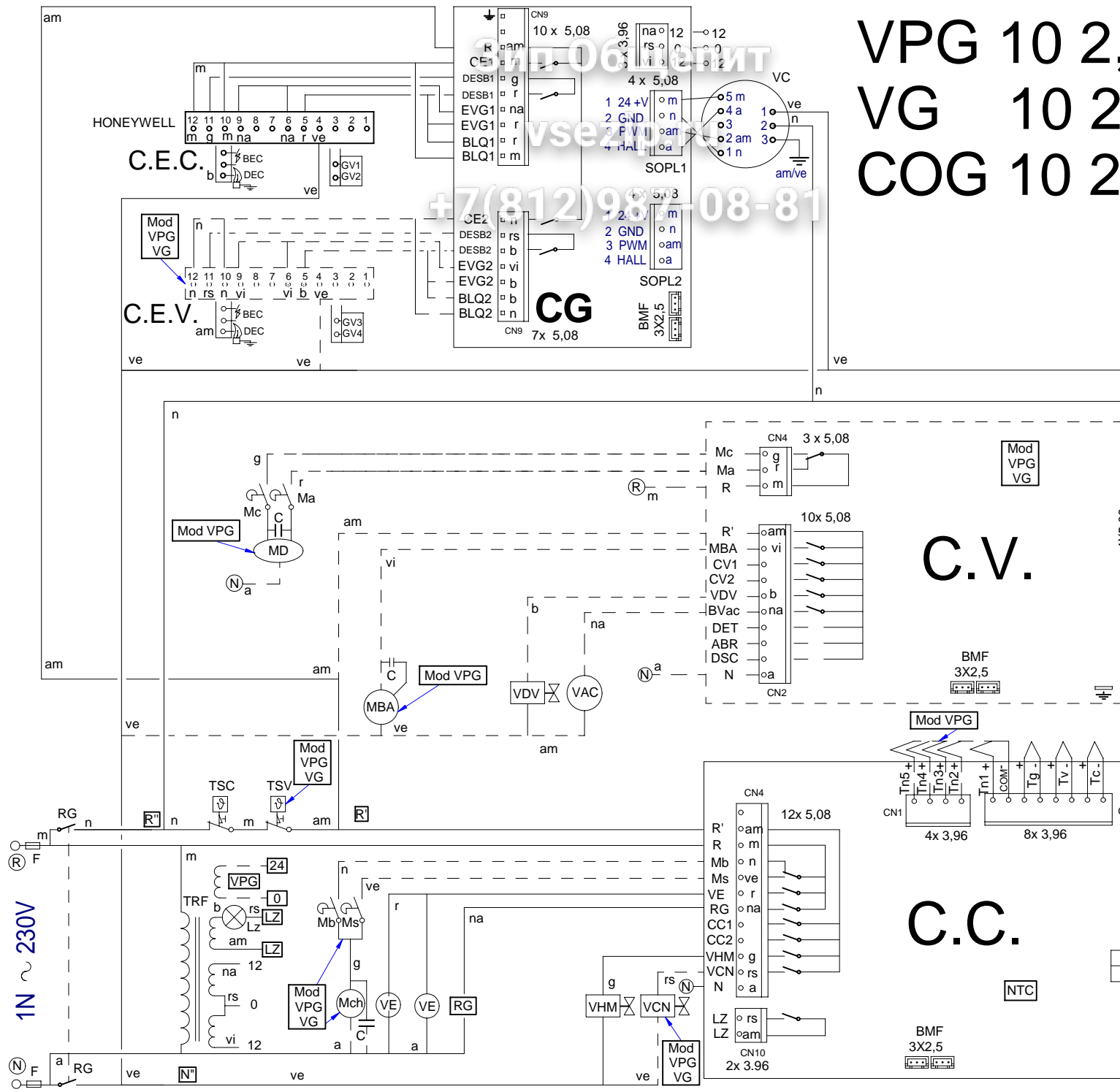

Зип Общепит

vsezip.ru

+7(812)987-08-81

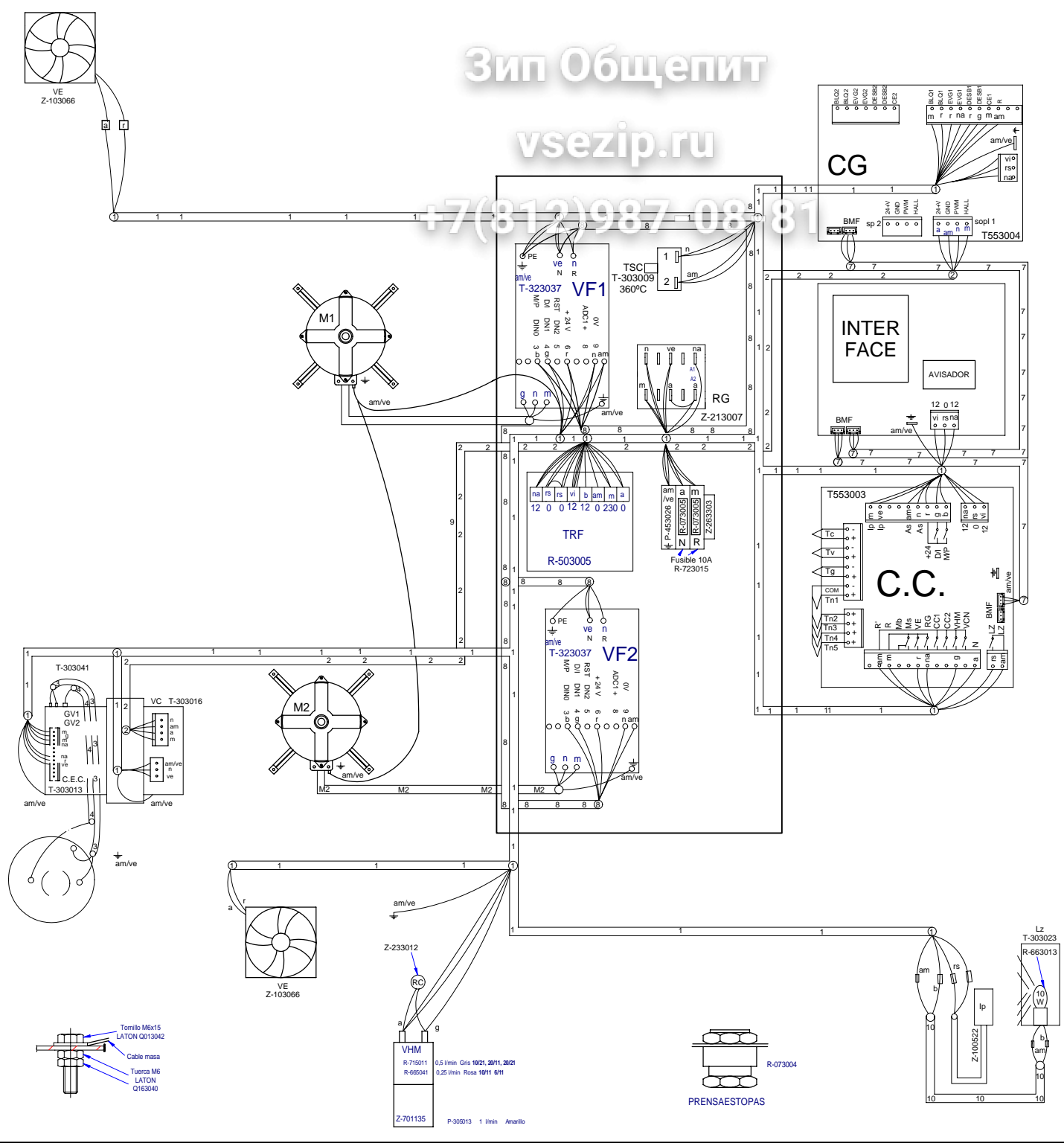

Зип Общепит
vsezip.ru

+7(812)087-08-81

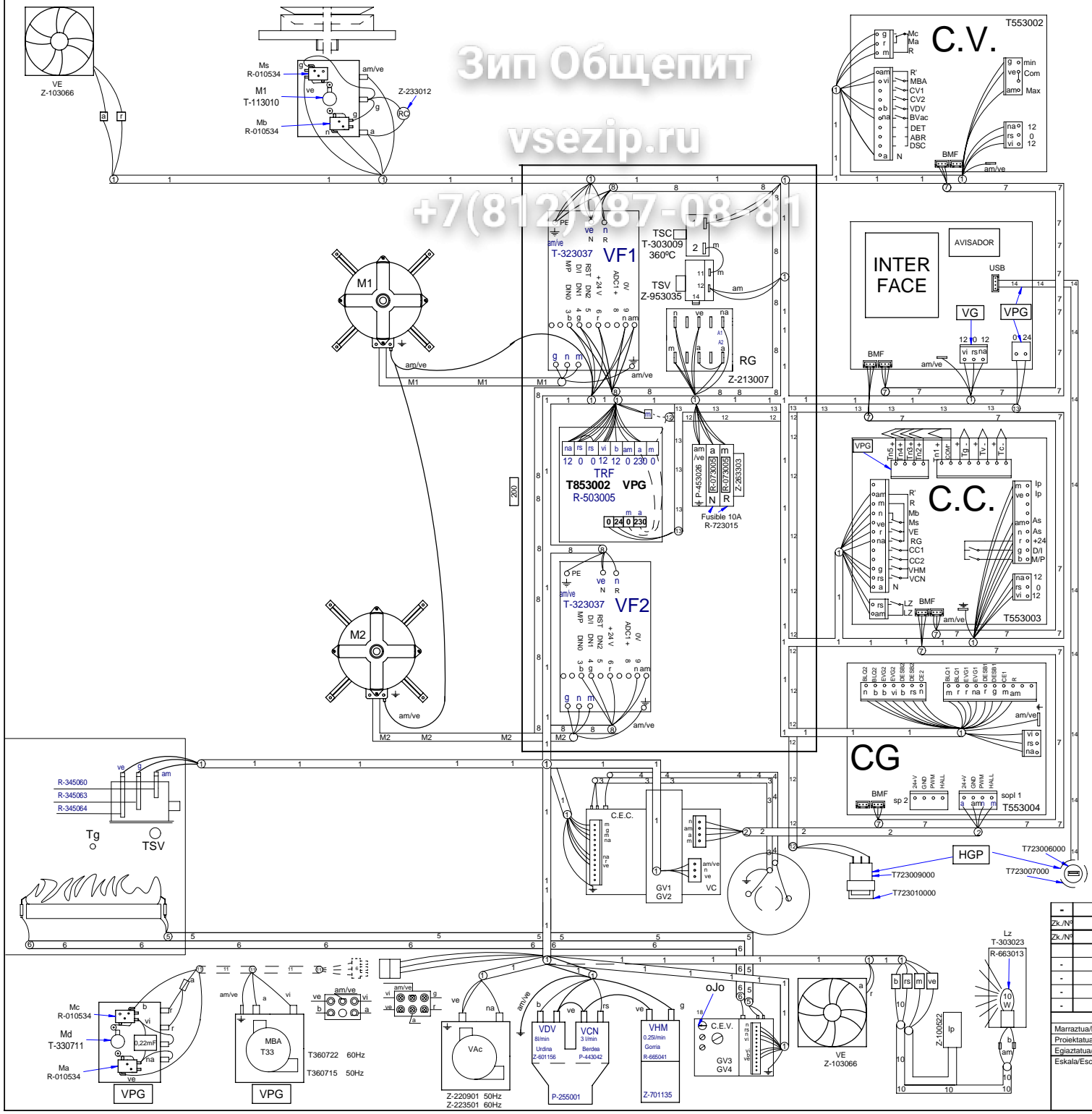

	ESPAÑOL	FRANÇAIS	ENGLISH	DEUTSCH
BEC	Bujía Encendido Cámara	Bougie Allumage Chambre	Chamber Spark Plug	Zündkerze Einschalten Ga
BEV	Bujía Encendido Caldera	Bougie Allumage Chaudière	Boiler Spark Plug	Zündkerze Einschalten Bo
C.C.	Control Camara	Contrôle Chambre	Chamber Control	Steuerung Garraum
C.E.C	Control Combustión Cámara	Contrôle Combustion Chambre	Chamber Combustion Control	Steuerung Verbrennung Ga
C.E.V	Control Combustión Caldera	Contrôle Combustion Chaudière	Boiler Combustion Control	Steuerung Verbrennung Bo
C.G.	Control Gas	Contrôle Gaz	Control Gas	Steuern Sie Gas
C.V.	Control Caldera	Contrôle Chaudière	Boiler Control	Steuerung Boiler
CC1, CC2	Contactador Resistencia Cámara	Contacteur Élément Chauffant Chambre	Chamber Heating Element Contactor	Schütz Heizwiderstand Ga
CK1, CK2	Contactador General Calentamiento	Relais Élément Chauffant	Heating Element Relay	Relais Heizwiderstand
CV1, CV2	Contactador Resistencias Caldera	Contacteur Élément Chauffant Chaudière	Boiler Heating Element Contactor	Schütz Heizwiderstand Bo
DEC	Detector Llama Cámara	Détecteur Flamme Chambre	Chamber Flame Detector	Flammendetektor Garraum
DEV	Detector Llama Caldera	Détecteur Flamme Chaudière	Boiler Flame Detector	Flammendetektor Boiler
DN	Detector Nivel Caldera	Détecteur Niveau Chaudière	Boiler Level Detector	Pegeldetektor Boiler
F	Fusibles	Fusibles	Fuses	Sicherungen
FI	Filtro Interferencias	Filtre Interférences	Interference Filter	Störungsfilter
FM	Térmico Motor	Thermique Moteur	Thermal Engine	Thermoschalter Motor
GV1, GV2	Electro válvula Gas Cámara	Électrovanne Gaz Chambre	Chamber Gas Solenoid Valve	Elektroventil Gas Garraum
GV3, GV4	Electro válvula Gas Caldera	Électrovanne Gaz Chaudière	Boiler Gas Solenoid Valve	Elektroventil Gas Boiler
Ip	Interruptor Seguridad Puerta	Interrupteur Sécurité Porte	Door Safety Switch	Sicherheitsschalter Tür
Lz	Luz Interior	Éclairage Intérieur	Inner Light	Innenbeleuchtung
M, M2	Motor Turbina	Moteur Turbine	Turbine Engine	Motor Turbine
Ma	Interruptor Micro Abierto	Microrupteur Ouvert	Open Microswitch	Mikroschalter Geöffnet
Mb	Interruptor Micro Bajada	Microrupteur Descente	Drop Microswitch	Mikroschalter Senken
Mc	Interruptor Micro Cerrado	Microrupteur Fermé	Closed Microswitch	Mikroschalter Geschlossen
Mch	Motor Chimenea	Moteur Cheminée	Stack Engine	Motor Abluftkamin
MD	Motor Desague	Moteur évacuation	Drain Engine	Motor Abfluss
Ms	Interruptor Micro Subida	Microrupteur Montée	Rise Microswitch	Mikroschalter Heben
PF	Potenciómetro Selector Funciones	Potentiomètre Sélecteur Fonctions	Functions Selector Potentiometer	Potentiometer Funktionsw
RC	Resistencias Cámara	Éléments Chauffants Chambre	Chamber Heating Element	Heizwiderstände Garraum
RG	Rele General	Relais Général	Main Relay	Hauptrelais
RV	Resistencias Caldera	Éléments Chauffants Chaudière	Boiler Heating Element	Heizwiderstände Boiler
Tc	Sonda Cámara	Sonde Chambre	Chamber Probe	Sonde Garraum
TCN	Termostato Condensación	Thermostat Condensation	Condensation Thermostat	Thermostat Kondensierung
Tg	Sonda Caldera	Sonde Chaudière	Boiler Probe	Sonde Boiler
Tn	Sonda Núcleo	Sonde Noyau	Core Probe	Kerntemperaturmesssonde
TRF	Transformador	Transformateur	Transformer	Transformator
TSC	Termostato Seguridad Cámara	Thermostat Sécurité Chambre	Chamber Safety Thermostat	Sicherheitsthermostat Gar
TSV	Termostato Seguridad Caldera	Thermostat Sécurité Chaudière	Boiler Safety Thermostat	Sicherheitsthermostat Boi
Tv	Sonda Vapor	Sonde Vapeur	Steam Probe	Sonde Dampf
VAC	Bomba Vaciado	Pompe Vidange	Vacuum Pump	Ablasspumpe
MBA	Moto Bomba Aclarado	Pompe Rinçage	Rinsing Pump	Pumpe Ausspülen
VC1, VC2	Ventilador Soplante Camara	Ventilateur Soufflant	Blowing Fan	Ventilator Gebläse
VCN	Electro válvula Condensación	Électrovanne Condensation	Condensation Solenoid Valve	Elektroventil Kondensierun
VDV	Electro válvula Llenado Caldera	Électrovanne Remplissage Chaudière	Chamber Filling Solenoid Valve	Elektroventil Füllung Boiler
VE	Ventilador Cuadro Eléctrico	Ventilateur Tableau Électrique	Fan Switchboard	Ventilator Elektrotafel
VF1, VF2	Variador de Frecuencia	Variateur Vitesse	Speed Variator	Geschwindigkeitsregler
VHM	Electro válvula Humidificador	Électrovanne Humidificateur	Humidifier Solenoid Valve	Elektroventil Befeuchtungs
Vv	Ventilador Soplante Caldera	Ventilateur soufflement chaudière	Boiler Blowing Fan	Durchbrennenventilator zur
	COLORES	COULEURS	COLOUR	FARBEN
a	Azul	Bleu	Blue	Blau
am	Amarillo	Jaune	Yellow	Gelb
am/ve	Amarillo/verde	Jaune / vert	Yellow / green	Gelb/grün
b	Blanco	Blanc	White	Weiß
g	Gris	Gris	Grey	Grau
m	Marrón	Marron	Brown	Braun
n	Negro	Noir	Black	Schwarz
na	Naranja	Orange	Orange	Orange
r	Rojo	Rouge	Red	Rot
rs	Rosa	Rose	Pink	Rosa
ve	Verde	Vert	Green	Grün
vi	Violeta	Violet	Purple	Violett