



FR7-4E...
FR7-7E...

SERIE 700

Зип Общепит
vsezip.ru
+7(812)987-08-81

FRIGGITRICI ELETTRICHE
ELECTRIC HEATED FRYERS
FRITEUSES ELECTRIQUES
ELEKTRO FRITEUSEN
FREIDORAS ELECTRICAS

93868-20 FR7-4E
93670-00 FR7-4E/2
93870-20 FR7-7E
93671-00 FR7-7E/2

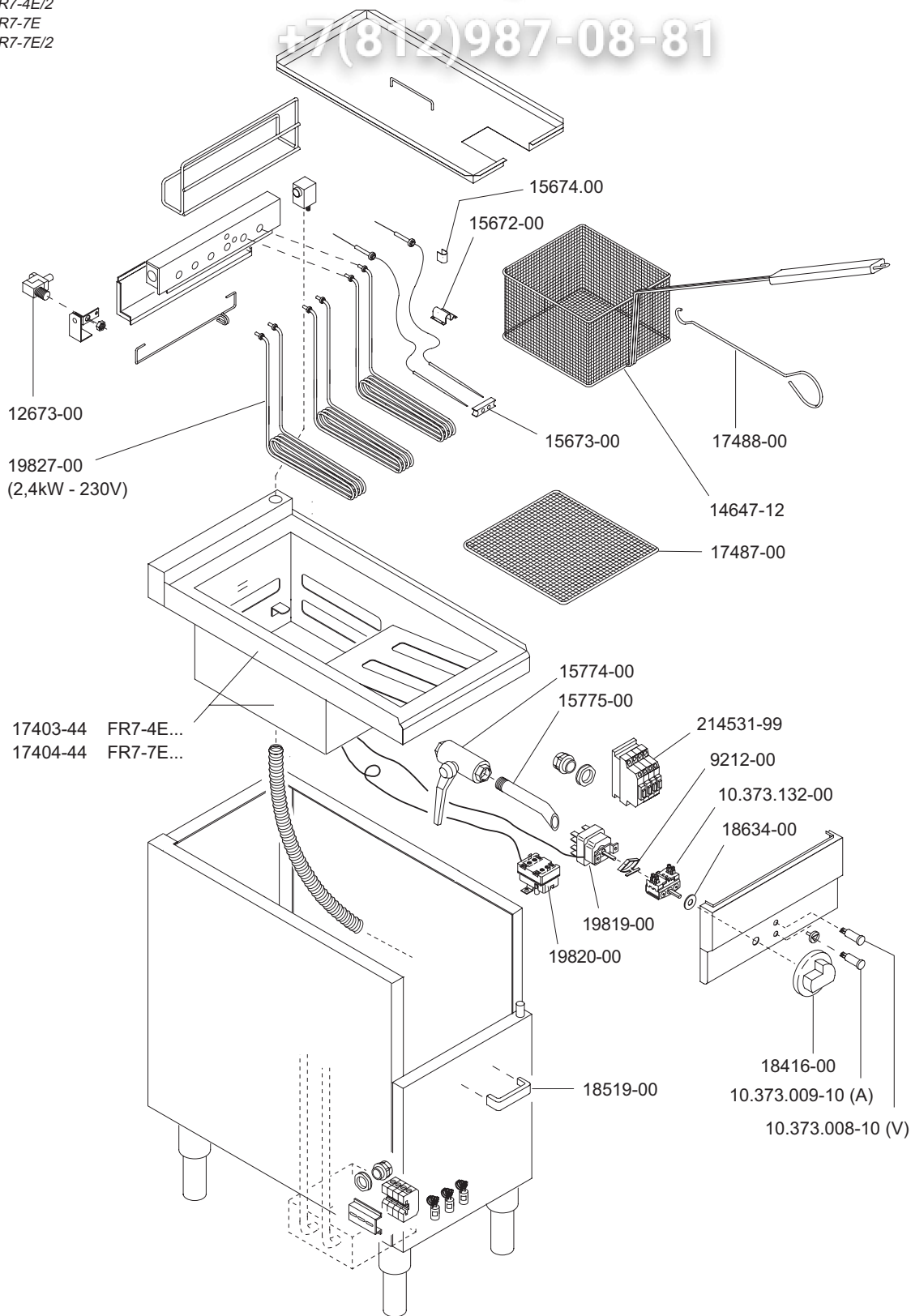

 MARENO INDUSTRIE ALI spa Mareno di Piave (TV)	ELABORATO:	APPROVATO:	GRUPPO:	DENOMINAZIONE:		
	<i>Plum</i>		Serie 700	Impianto elettrico friggitrice da 22 litri		
	DATA:	DATA:	PARTICOLARE:	REV. N.	DEL	DISEGNO N.
	10 Gen 97	10 Gen 97	Disegno esploso per ricambi	▼	▼	▼
SOST. DIS.	Z00 - 9701.3.7.01.FRE		Z00 - 9701.3.7.01.FRE			

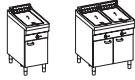

FR7-4E
FR7-7E

SERIE 700

Зип Общепит
vsezip.ru

FRIGGITRICI ELETTRICHE
ELECTRIC HEATED FRYERS
FRITEUSES ELECTRIQUES
ELEKTRO FRITEUSEN
FREIDORAS ELECTRICAS

93868-10 FR7-4E
93870-10 FR7-7E

+7(812)987-08-81

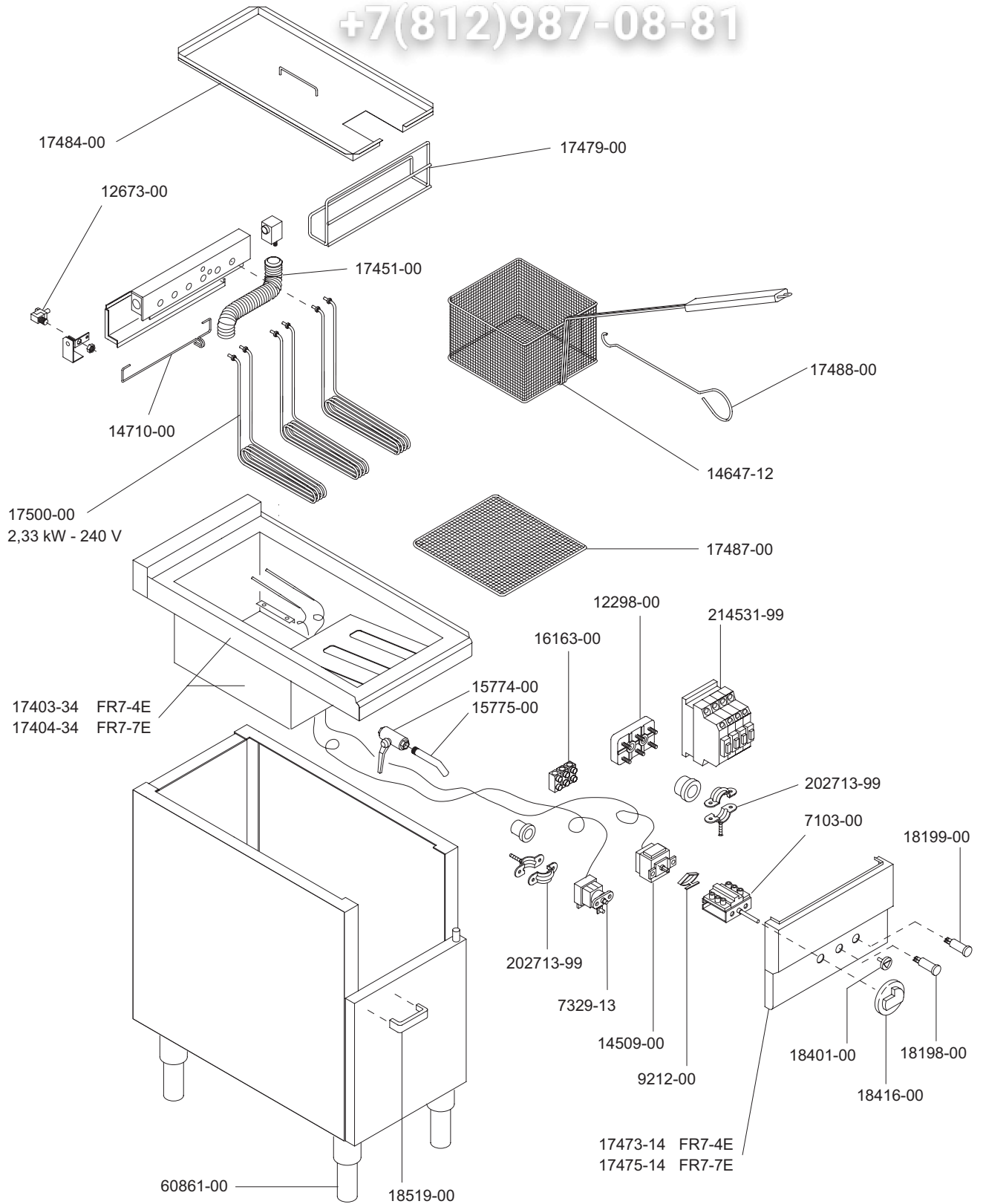

 MARENO INDUSTRIE ALI spa Mareno di Piave (TV)	ELABORATO:	APPROVATO:	GRUPPO:	DENOMINAZIONE:		
	<i>Plum</i>		Serie 700	Impianto elettrico e mobile		
	DATA: 10 Nov 96	DATA: 10 Nov 96	PARTICOLARE:	REV. N. ▼	DEL ▼	DISEGNO N. ▼
	SOST. DIS.	Z02 - 9611.3.7.21.FRE		Z02 - 9611.3.7.21.FRE		

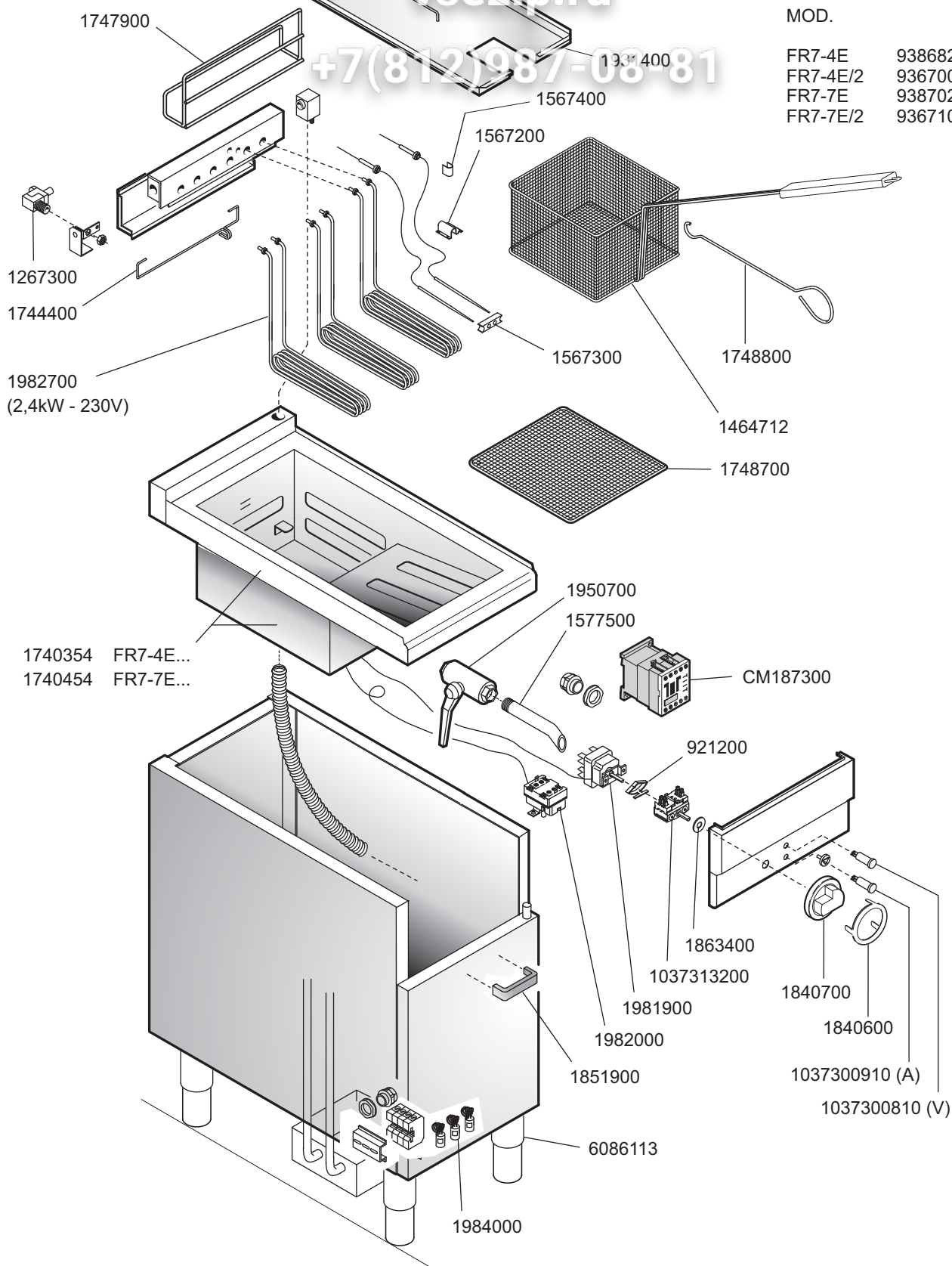

MOD.

FR7-4E	9386820
FR7-4E/2	9367000
FR7-7E	9387020
FR7-7E/2	9367100

 MARENO INDUSTRIE ALI spa Mareno di Piave (TV)	ELABORATO:	APPROVATO:	GRUPPO:	DENOMINAZIONE:		
	G.Z.		Serie 700	Impianto elettrico e mobile		
	DATA:	DATA:	PARTICOLARE:	REV. N.	DEL	DISEGNO N.
	24 Nov 1996	24 Nov 1996	Disegno esploso per ricambi	Z01	0303	3.7.01
SOST. DIS.	Z00 9701 3.7.01.FRE					