

+7(812)987-08-81

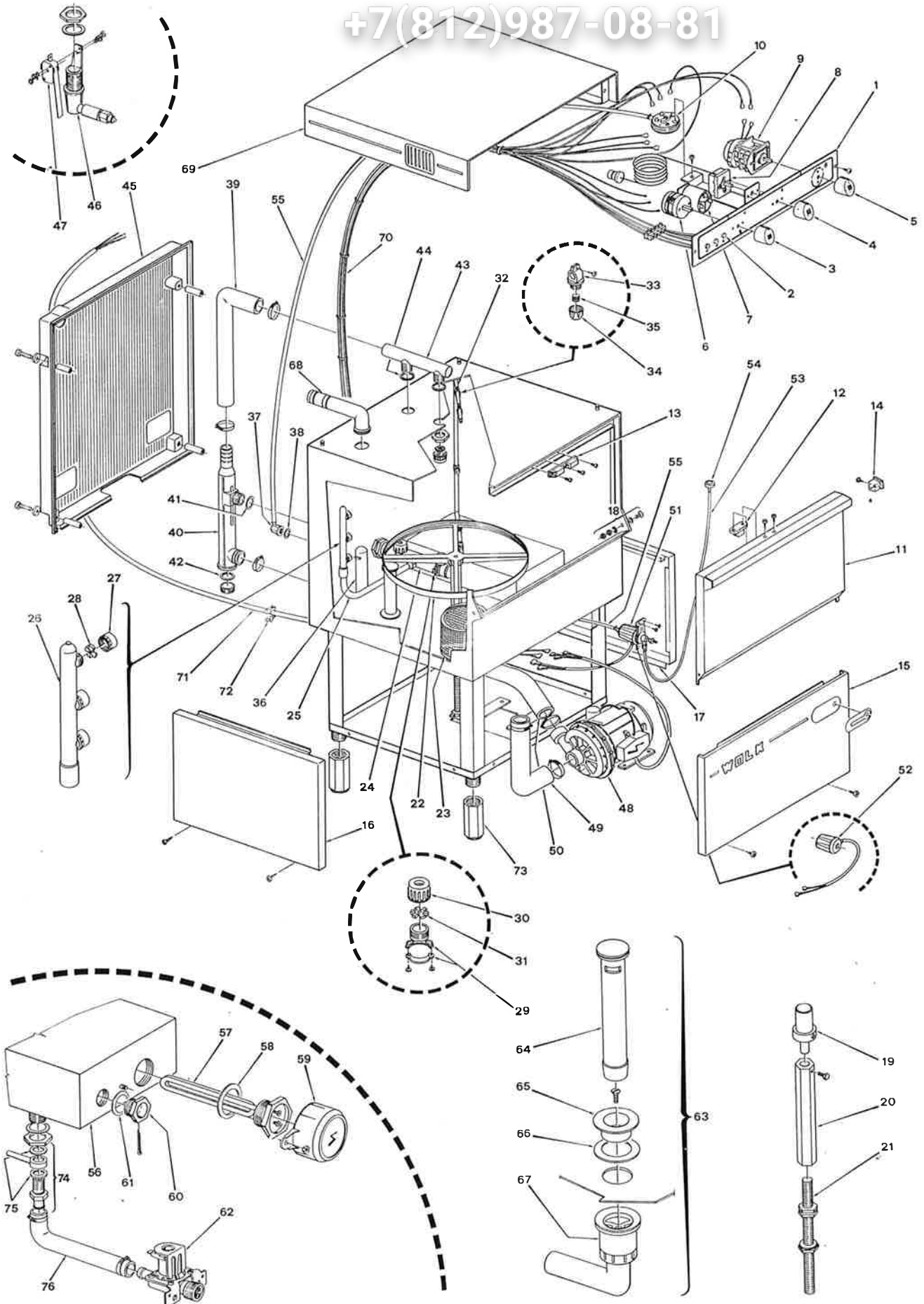

OS.	CODICE CODE KODE	POS.	CODICE CODE KODE	POS.	CODICE CODE KODE	POS.	CODICE CODE KODE
1	02 50 03	33	11 00 02	62	pag. 93		
2	{ 21 60 02	34	14 00 06	63	99 90 20		
	21 60 03	35	13 80 01	64	14 20 11		
3	44 70 07	36	98 40 02	65	14 20 01		
4/5	44 70 08	37	46 80 29	66	{ 43 70 38		
6	21 30 02	38	{ 45 60 20		43 70 33		
7	21 20 01		43 70 19	67	99 90 43		
8	23 60 07	39	12 70 10	68	10 80 04		
9	pag. 90	40	99 90 32	69	00 40 08		
10	22 40 02	41	43 70 27	70	20 30 33		
11	99 90 26	42	45 60 16	71	20 40 14		
12	12 30 02	43	99 00 29	72	42 50 01		
13	99 40 01	44	43 70 25	73	46 10 06		
	{ 48 00 15	45	45 80 01	74	99 10 01		
48 00 16		46	99 90 08	75	43 70 07		
15	02 00 07	47	21 80 02	76	14 30 04		
16	02 10 12	48	pag. 101				
17	02 10 05	49	12 70 08				
18	99 90 04	50	12 70 09				
19	32 20 03	51	{ 98 70 01				
20	99 90 29		98 70 05				
21	99 90 33	52	{ 20 10 02				
22	31 90 02		20 10 11				
23	12 10 12	53	14 30 13				
24	99 00 27	54	12 10 17				
25	99 00 28	55	14 30 05				
26	99 90 30	56	98 20 09				
27	14 00 02	57	{ 23 00 07				
28	11 90 01		23 00 21				
		58	43 70 28				
29	11 00 05	59	41 50 01				
30	14 00 03	60	43 50 01				
31	11 90 02	61	43 70 31				
32	99 30 27						

Эл.Общепит

vsezip.ru

+7(812)987-08-81



E3 wolk

Timer serie «R» - Timer «R» range

Programmateur serie «R» - Programmschalter Serie «R»

91

10/87

Q.S.	CODICE CODE KODE	DESCRIZIONE - DESCRIPTION - BESCHREIBUNG
1	23 80 25	Timer ciclo 180" - Cronel 2C Cycle timer 180" - Cronel 2C Programmateur cycle 180" - Cronel 2C Programmschalter 180" - Cronel 2C
1	23 80 01	Timer ciclo 180" - Crouzet 3C Cycle timer 180" - Crouzet 3C Programmateur cycle 180" - Crouzet 3C Programmschalter 180" - Crouzet 3C
1	23 80 24	Timer ciclo 180" - Cronel 3C Cycle timer 180" - Cronel 3C Programmateur cycle 180" - Cronel 3C Programmschalter 180" - Cronel 3C
1	23 80 05	Timer ciclo 180" - Cronel 3C Cycle timer 180" - Cronel 3C Programmateur cycle 180" - Cronel 3C Programmschalter 180" - Cronel 3C
1	23 80 16	Timer ciclo 180" - Cronel 3C Cycle timer 180" - Cronel 3C Programmateur cycle 180" - Cronel 3C Programmschalter 180" - Cronel 3C

E3 wolk

Timer serie «R»

Programmateur serie «R»

POS.	CODICE CODE KODE	
1	23 80 09	Timer pompa Drain pump t Programmate Laugenpump
2	21 80 09	Micro timer C Microtimer C Minirupteur p Mikroschalter

Этп Общепит

vsezip.ru

+7(812)987-08-81

+7(812)987-08-81



POS.	CODICE CODE KODE	DESCRIZIONE - DESCRIPTION - BESCHREIBUNG
1	24 00 06	Valvola - Elbi - 1 via 90° Solenoid valve - Elbi - 1 way 90° Vanne - Elbi - 1 bobine 90° Einweg - Einlassmagnetventil - Elbi - 90° 220-240/50-60/1 Mod. R 495
1	24 00 05	Valvola - Elbi - 1 via 180° Solenoid valve - Elbi - 1 way 180° Vanne - Elbi - 1 bobine 180° Einweg - Einlassmagnetventil - Elbi - 180° 220-240/50-60/1 Mod. R 704 - 706
1	24 00 03	Valvola - 2 vie 180° Solenoid valve - 2 ways 180° Vanne - 2 bobines 180° Zweiweg - Einlassmagnetventil - 180° 220-240/50-60/1 Mod. R 497 - 499 - 501 - 505 - 509 - S 641
1	24 00 02	Valvola - 3 vie 180° Solenoid valve - 3 ways 180° Vanne - 3 bobines 180° Dreiweg - Einlassmagnetventil - 180° 220-240/50-60/1 Mod. R 503 - 507 - 511 - S 643
1	24 00 08	Valvola ottone piccola portata Brass solenoid valve - small capacity Vanne laiton - petite Kleines Einlassmagnetventil aus Messing 220-240/50-60/1 Mod. R 708
1	24 00 07	Valvola ottone grande portata Brass solenoid valve - big capacity Vanne laiton - grande Grosses Einlassmagnetventil aus Messing 220-240/50-60/1 Mod. S 870 fino matricola n° 64902 till serial no. 64902 au matricule n° 64902 bis Maschinen-Nr. 64902

OS.	CODICE CODE KODE	DESCRIZIONE - DESCRIPTION - BESCHREIBUNG
2	20 10 06	Bobina va Coil for so Bobine po Spule für
2	20 10 08	Bobina va Coil for br Bobine va Spule für
2	20 10 07	Bobina va Coil for br Bobine va Spule für
3	29 90 22	Membrana Membrane Membrane Membran

Зин Общепит

vsezip.ru

+7(812)987-08-81

POMPA
WASH PUMP
POMPE
ELEKTROPUMPE

mod. R:
509 - 511 - 704

Зип Общепит

101

10/87

vsezip.ru

+7(812)987-08-81

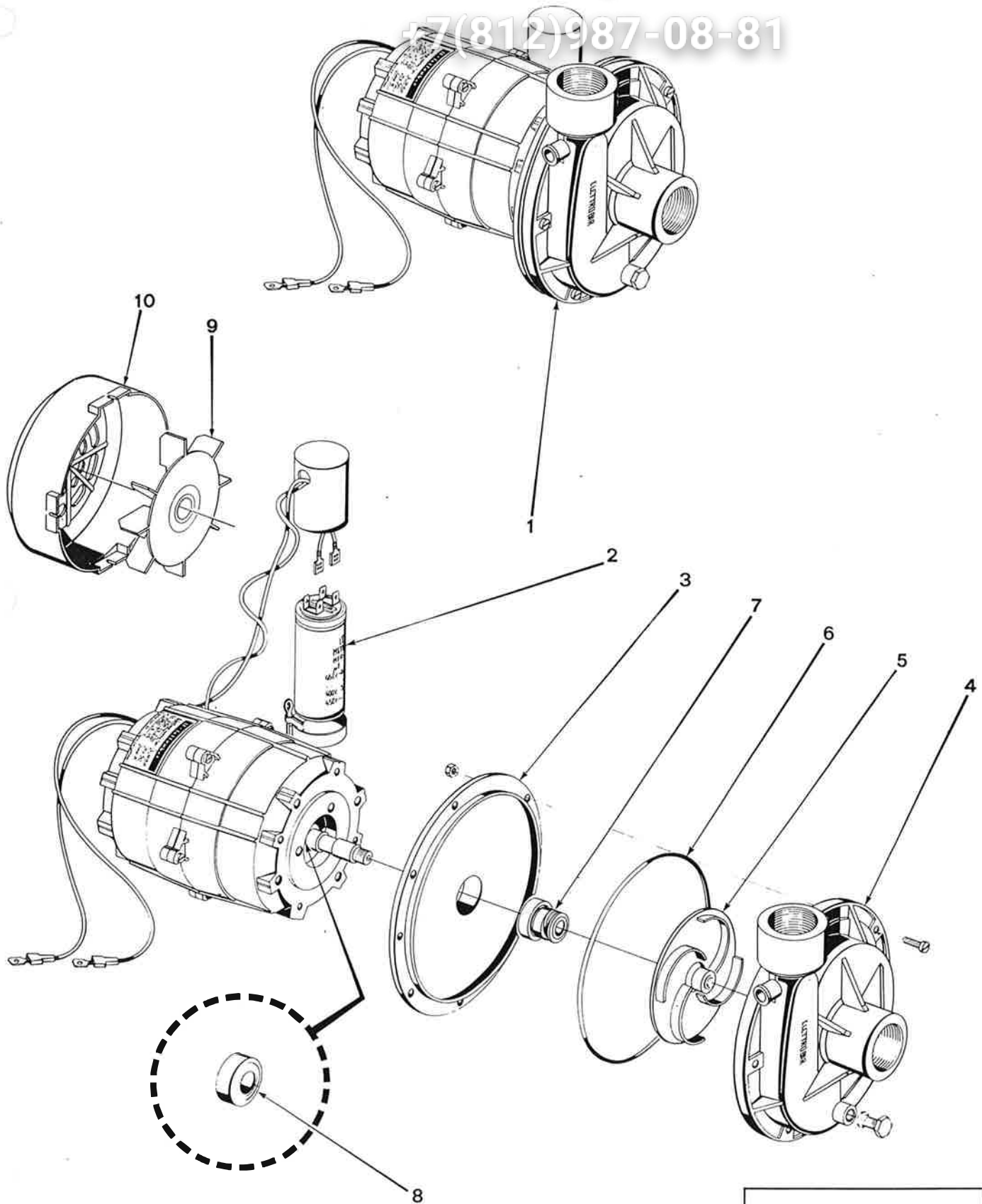

Э волк

POMPA
WASH PUMP
POMPE
ELEKTROPUMPE

mod. R:
509 - 511 - 704

Зип Общежитие

102
10/87

F PA
WASH PUMP
POMPE
ELEKTROPUMPE

mod. R:
509 - 511 - 704

PCS.	CODICE CODE KODE	DESCRIZIONE - DESCRIPTION - BESCHREIBUNG	POS.	CODICE CODE KODE	DESCRIZIONE - DESCRIPTION - BESCHREIBUNG
1	13 00 16	Pompa T 20 HP 0,7 Wash pump T 20 HP 0,7 Pompe T 20 HP 0,7 Elektropumpe T 20 HP 0,7	5	12 40 21	Girante T 20 60 Hz. Impellor T 20 60 Hz. Turbine T 20 60 Hz. Pumpenflügel T 20 60 Hz.
1	13 00 10	Pompa T 20 HP 0,7 Wash pump T 20 HP 0,7 Pompe T 20 HP 0,7 Elektropumpe T 20 HP 0,7	5	12 40 03	Girante 1296 FIR 50 Hz. Impellor 1296 FIR 50 Hz. Turbine 1296 FIR 50 Hz. Pumpenflügel 1296 FIR 50 Hz.
1	13 00 31	Pompa T 20 HP 0,7 Wash pump T 20 HP 0,7 Pompe T 20 HP 0,7 Elektropumpe T 20 HP 0,7	6	45 60 24	OR T 20 O-ring T 20 Joint thorique T 20 O-Ring Dichtung T 20
2	20 60 03	Condensatore T 20 1296 FIR Condenser T 20, 1296 FIR Condensateur T 20, 1296 FIR Kondensator T 20, 1296 FIR	6	43 70 44	OR 1296 FIR O-ring 1296 FIR Joint thorique 1296 FIR O-Ring Dichtung 1296 FIR
3	31 50 08	Flangia T 20 Flange int. T 20 Flansque int. T 20 Flansch T 20	7	14 10 02	Tenuta meccanica T 20, 1296 FIR Seal T 20, 1296 FIR Presse etoupe T 20, 1296 FIR Gleitringdichtung T 20, 1296 FIR
3	31 50 03	Flangia + cappello 1296 FIR Flange 1296 FIR Flansque 1296 FIR Flansch 1296 FIR	8	31 40 02	Cuscinetto T 20, 1296 FIR Bearing T 20, 1296 FIR Roulement T 20, 1296 FIR Kugellager T 20, 1296 FIR
4	11 60 10	Corpo pompa T 20 Flange ext. T 20 Flansque ext. T 20 Pumpengehäuse T 20	9	33 50 04	Ventola T 20 Fan T 20 Turbine de refroidissement Flügel T 20
4	11 60 03	Corpo pompa 1296 FIR Flange ext. 1296 FIR Flansque ext. 1296 FIR Pumpengehäuse 1296 FIR	9	33 50 02	Ventola 1296 FIR Fan 1296 FIR Turbine de refroidissement Flügel 1296 FIR
5	12 40 08	Girante T 20 50 Hz. Impellor T 20 50 Hz. Turbine T 20 50 Hz. Pumpenflügel T 20 50 Hz.	10	31 30 04	Copriventola T 20 Fan protection T 20 Protection turbine T 20 Flügelschutz T 20
			10	31 30 02	Copriventola 1296 FIR Fan protection 1296 FIR Protection turbine 1296 FIR Flügelschutz 1296 FIR

E3 wolk

+7(812)987-08-81

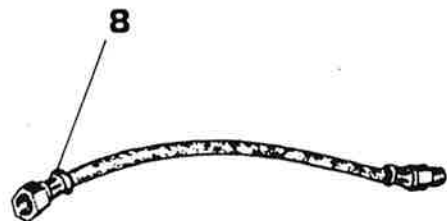
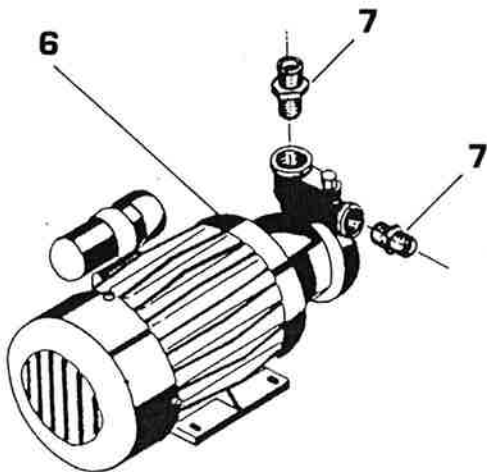
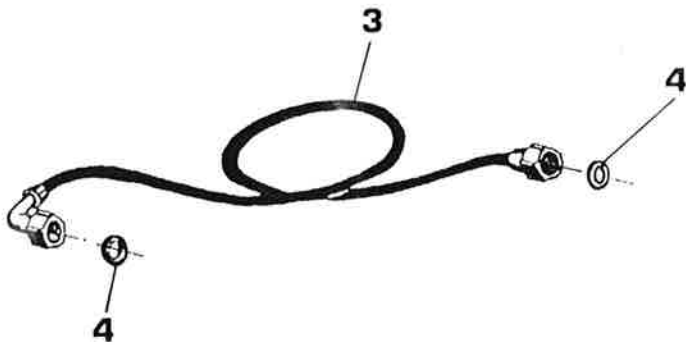
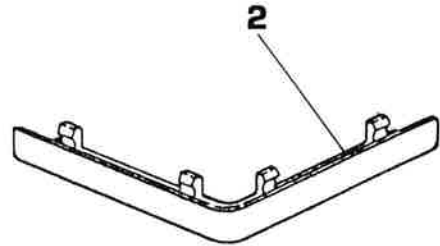

www.Общественный
vsezip.ru

+7(812)987-08-81

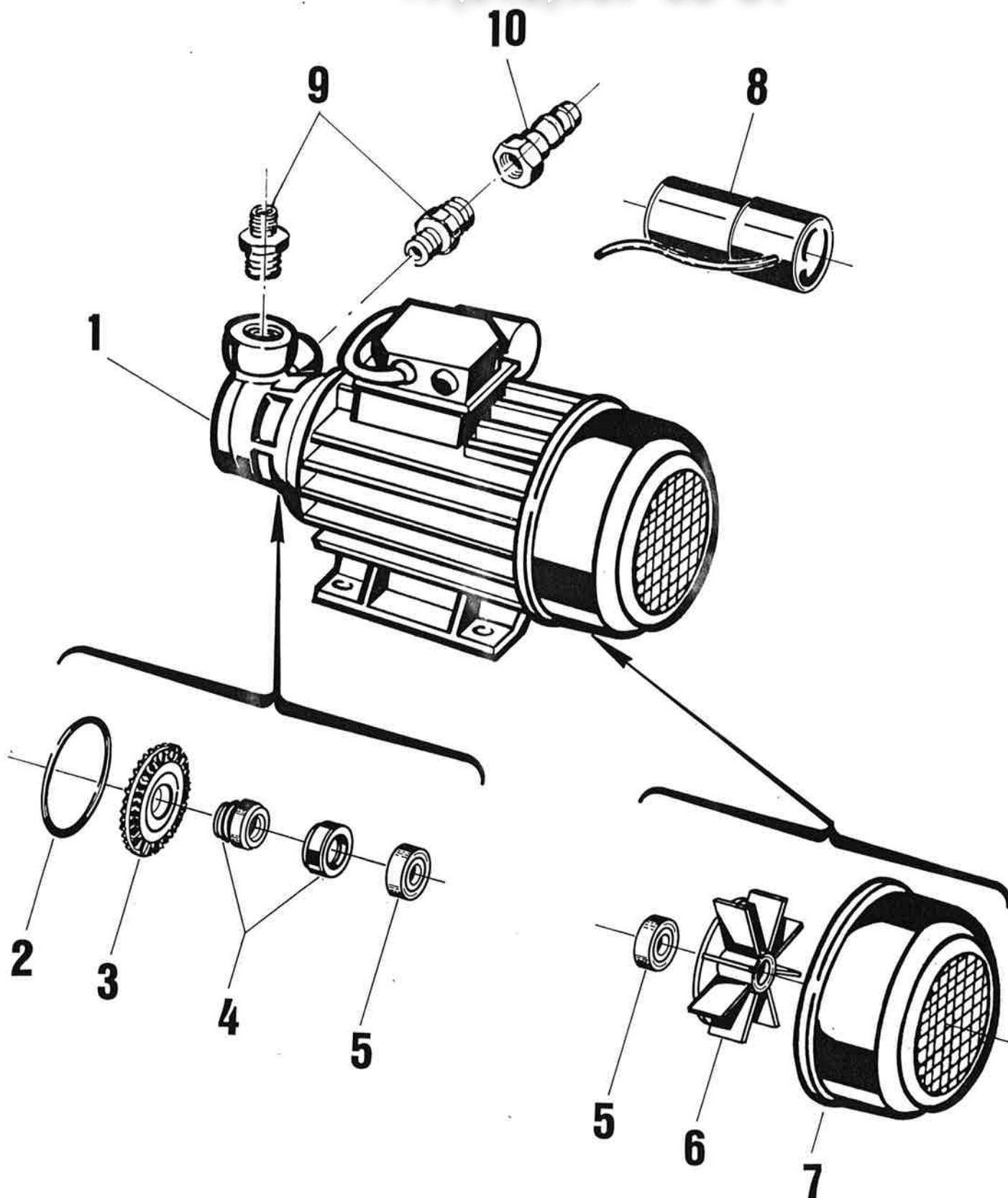

DESCRIZIONE - DESCRIPTION - BESCHREIBUNG

+7(812)987-08-81

POS.	CODICE CODE KODE	DESCRIZIONE - DESCRIPTION - BESCHREIBUNG
1	13 00 13	Pompa ausiliaria Dab K 30 HP 0,4 Rinse booster pump Dab K 30 HP 0,4 Pompe rincage Dab K 30 HP 0,4 Nachspülpumpe Dab K 30 HP 0,4 220/50/1 Per tutti i modelli For all the models Tous modeles Für alle Modelle
1	13 00 52	Pompa ausiliaria Dab K 30 HP 0,4 Rinse booster pump Dab K 30 HP 0,4 Pompe rincage Dab K 30 HP 0,4 Nachspülpumpe Dab K 30 HP 0,4 240/50/1 Per tutti i modelli For all the models Tous modeles Für alle Modelle
2	45 60 37	OR K 30 O-ring K 30 Joint thorique K 30 O-Ring Dichtung K 30
3	12 40 15	Girante K 30 Impellor K 30 Turbine K 30 Pumpenflügel K 30
4	14 10 02	Tenuta meccanica K 30 Seal K 30 Presse etoupe K 30 Gleitringdichtung K 30
5	31 40 01	Cuscinetto K 30 Bearing K 30 Roulement K 30 Kugellager K 30
6	33 50 07	Ventola K 30 Fan K 30 Turbine de refroidissement K 30 Flügel K 30
7	31 30 08	Copriventola K 30 Fan protection K 30 Protection turbine K 30 Flügelschutz K 30
8	20 60 01	Condensatore K 30 Condenser K 30 Condensateur K 30 Kondensator K 30
9	46 80 26	Raccordo K 30 Connection K 30 Raccord K 30 Anschluss K 30
10	45 30 02	Raccordo pompa ausiliaria Dab K 30 Rinse booster pump connection Dab K 30 Raccord pompe rincage Dab K 30 Nachspülpumpeanschluss Dab K 30 Mod. S 850 - 870 - 950

+7(812)987-08-81

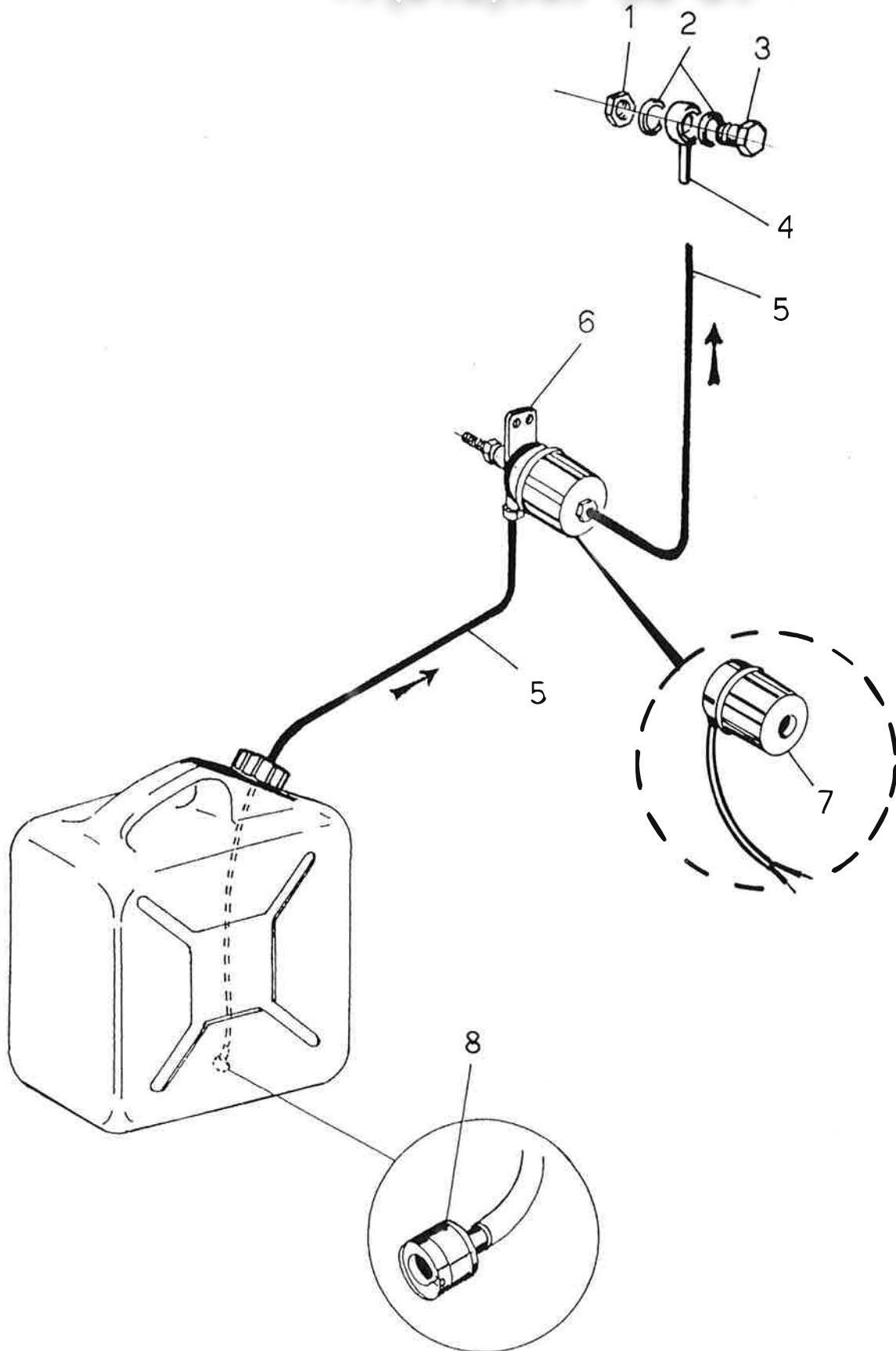



DOSATORE SAPONE
LIQUID DETERGENT DISPENSER
DOSEUR DU PRODUIT DE LAVAGE
SPUELMITTEL-DOSIERGERAET

121

10/87

POS.	CODICE CODE KODE	POS.	CODICE CODE KODE	POS.	CODICE CODE KODE	POS.	CODICE CODE KODE
1	41 70 16						
2	43 70 07						
3	46 80 24						
4	46 80 23						
5	14 30 14						
6	98 70 12						
7	20 10 18						
8	98 60 02						

+7(812)987-08-81

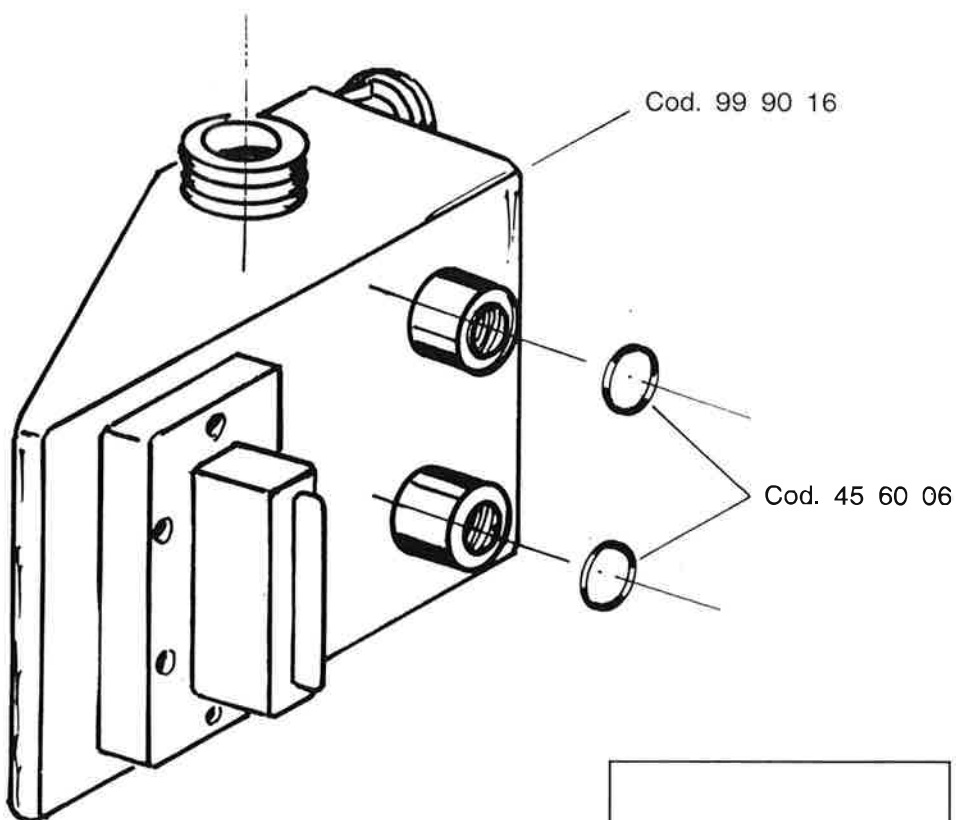
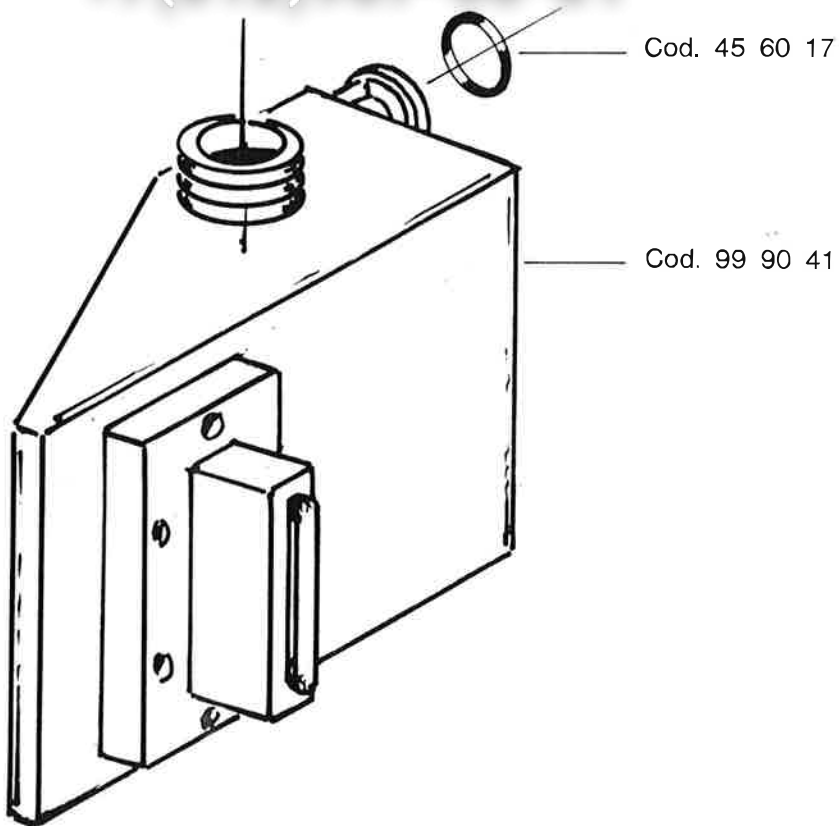

NUOVO
NEW
NOUVEAU
NEU

DA MATRICOLA N° 68473
DE MATRICULE NR. 68473
FROM SERIAL NO. 68473
AB MASCHINEN NR. 68473

E3 wolk

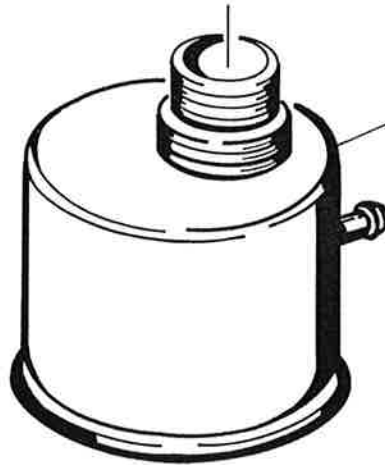
+7(812)987-08-81

Cod. 40 69 99

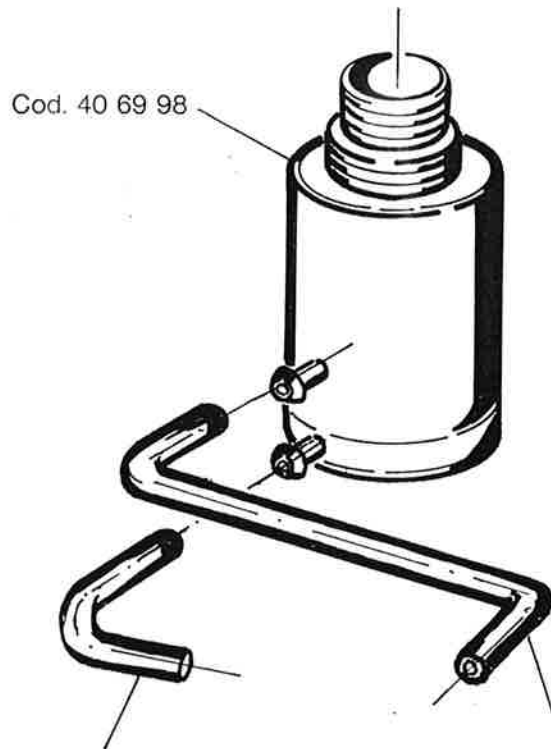

Cod. 40 69 98

Cod. 14 31 05

Cod. 14 31 06

**NUOVO
NEW
NEU
NOUVEAU**DA MATRICOLA N° 92582
FROM SERIAL NO. 92582
AB MASCHINEN NR. 92582
DU MATRICULE NO. 92582