

Зип Общепит
Service Manual

+7(812)987-08-81

TG 4 & TG110

MODELS

TG4
TG4 SB
TG110
TG110 SB



Model TG4



Model TG110

- NOTICE -

This manual is prepared for the use of trained Service Technicians and should not be used by those not properly qualified. If you have attended a training for this product, you may be qualified to perform all the procedures in this manual.

This manual is not intended to be all encompassing. If you have not attended a training for this product, you should read, in its entirety, the repair procedure you wish to perform to determine if you have the necessary tools, instruments and skills required to perform the procedure. Procedures for which you do not have the necessary tools, instruments and skills should be performed by a trained technician.

Reproduction or other use of this Manual, without the express written consent of Fri-Jado, is prohibited.



This manual covers the following units.

Part number	Model	Remarks
9049100	TG-4M	
9049110	TG-4M 230V SB	13A Solid Back
9049120	TG-4M 208V PT	
9049130	TG-4M 230V SB C UK	13A Solid Back, coated parts
9049140	TG-4M 200V +MB JPN	
9049019	TG-110-M Eurogrill	
9049021	TG-110-M Eurogrill JPN	
9049023	TG-110-M 13A/SB	
9049026	TG-110-M 230V/SB	
9049029	TG-110-M Eurogrill AUS	
9049041	TG-110-M-Eurogrill	coated parts
9049049	TG-110-M 208V USA	
9049051	TG-110-M 13A/SB C	13A Solid Back, coated parts

Versions
+7(812)987-08-81

Version	Issue date dd/mm/yy	Remarks
1607	22/07/2016	First release
1701	16/01/2017	Minor updates in exploded views and electrical drawings

Index	4
General Technical Data TG4 & TG110	6
TG110 And TG4, Technical Data.....	6
Service Instruction Blower TG4 and TG110	8
Service Instruction Heating el. TG4 and TG110	9
Service Instruction Rotor motor TG4 and TG110	10
Exploded views and partslists TG4 & TG110	12
TG110 And TG4, Electrical parts.....	12
TG110 and TG4, Partslist Electrical parts	13
TG110, Doors.....	14
TG110, Partslist Doors.....	15
TG4, Doors.....	16
TG4, Partslist Doors.....	17
TG110 and TG4, Illumination	18
TG110 and TG4, Partslist Illumination	19
TG110 and TG4, Rotor	20
TG110 and TG4, Partslist Rotor	21
TG110 and TG4, Heating	22
TG110 And TG4, Partslist Heating.....	23
TG110 and TG4, Sheet metal.....	24
TG110 and TG4, Partslist Sheet metal.....	25
TG110 and TG4, Insulation	26
TG110 and TG4, Partslist Insulation	27
Electrical diagrams TG4 and TG110	28
Circuit diagram TG4 and TG110 230V	28
Wiring diagram TG4 and TG110 230V.....	29
Circuit diagram TG4 and TG110 208V	30
Wiring diagram TG4 and TG110 208V.....	31
Circuit diagram TG4 SB (solid back).....	32
Wiring diagram TG4 SB (solid back)	33
Circuit diagram TG110 SB (solid back).....	34
Wiring diagram TG110 SB (solid back)	35

Зип Общепит

vsezip.ru

+7(812)987-08-81

EMPTY PAGE

Model	TG 4M	TG 4M SB	TG 110M	TG 110M SB
Dimensions				
- Width	825 mm	825 mm	825 mm	825 mm
- Depth	540 mm	540 mm	500 mm	500 mm
- Height	750 mm	750 mm	750 mm	750 mm
Weight				
- Gross	87 kg	87 kg	87 kg	87 kg
- Net	75 kg	75 kg	75 kg	75 kg
Maximum ambient temperature	35 °C	35 °C	35 °C	35 °C
Sound pressure	< 70 dB(A)	< 70 dB(A)	< 70 dB(A)	< 70 dB(A)
Electrical installation				
- Voltage	3~ 200-230V 3N~ 400/230V 1N~ 230V	3~ 200-230V 3N~ 400/230V 1N~ 230V	3~ 200-230V 3N~ 400/230V 1N~ 230V	3~ 200-230V 3N~ 400/230V 1N~ 230V
- Frequency	50/60 Hz	50/60 Hz	50/60 Hz	50/60 Hz
- Required power	5200 W	3100 W	5200 W	3100 W
Plug ¹	CEE-form 16 A	CEE-form 16 A / 2 pole + PE	CEE-form 16 A	CEE-form 16 A / 2 pole + PE
Length of power cable approx.	2,20 m	2,20 m	2,20 m	2,20 m

¹) Depending on Country

Зип Общепит

vsezip.ru

+7(812)987-08-81

EMPTY PAGE

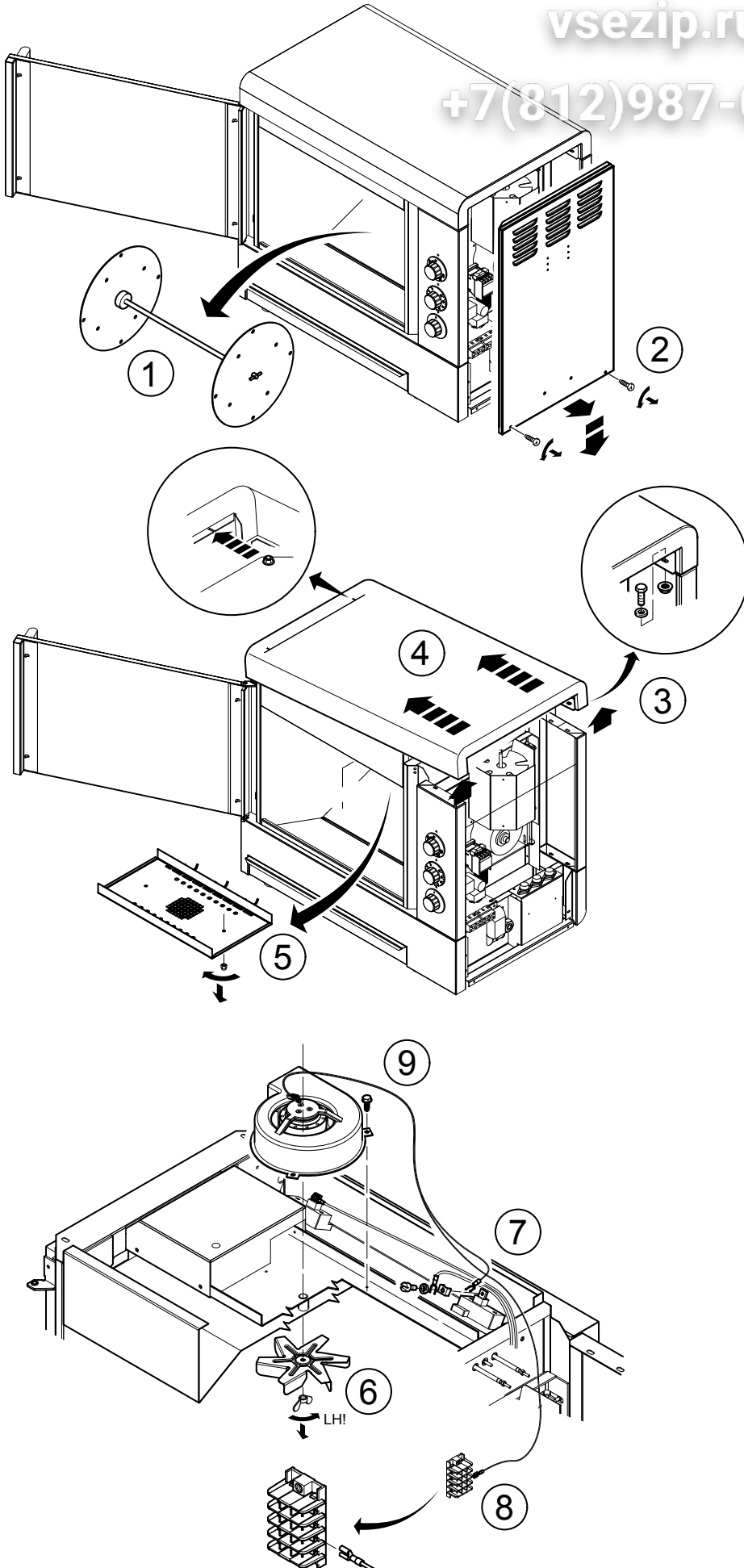

- 1 Remove the rotor
- 2 Remove the side panel
- 3 Remove 4 screws.
- 4 Lift and slide off the top panel.
- 5 Remove the blower panel
- 6 Unscrew the wingnut (left threaded) and take out the fan blade.
- 7 Disconnect the wire from the lamp connection.
- 8 Disconnect the wire from the terminal block.

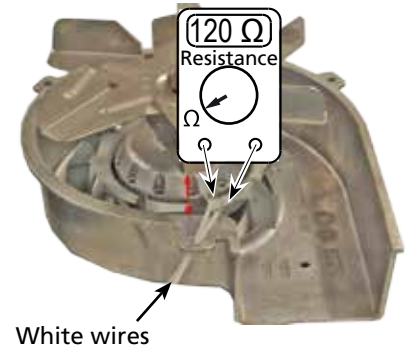

Blower 9070581 in 208V models only. thermistor protected

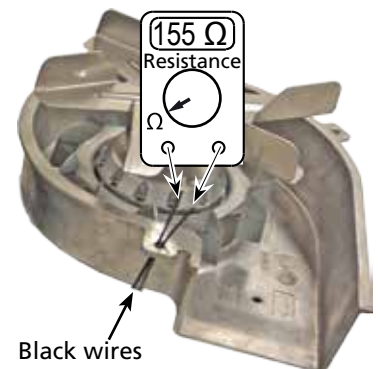

Зип Общепит

vsezip.ru

+7(812)987-08-81

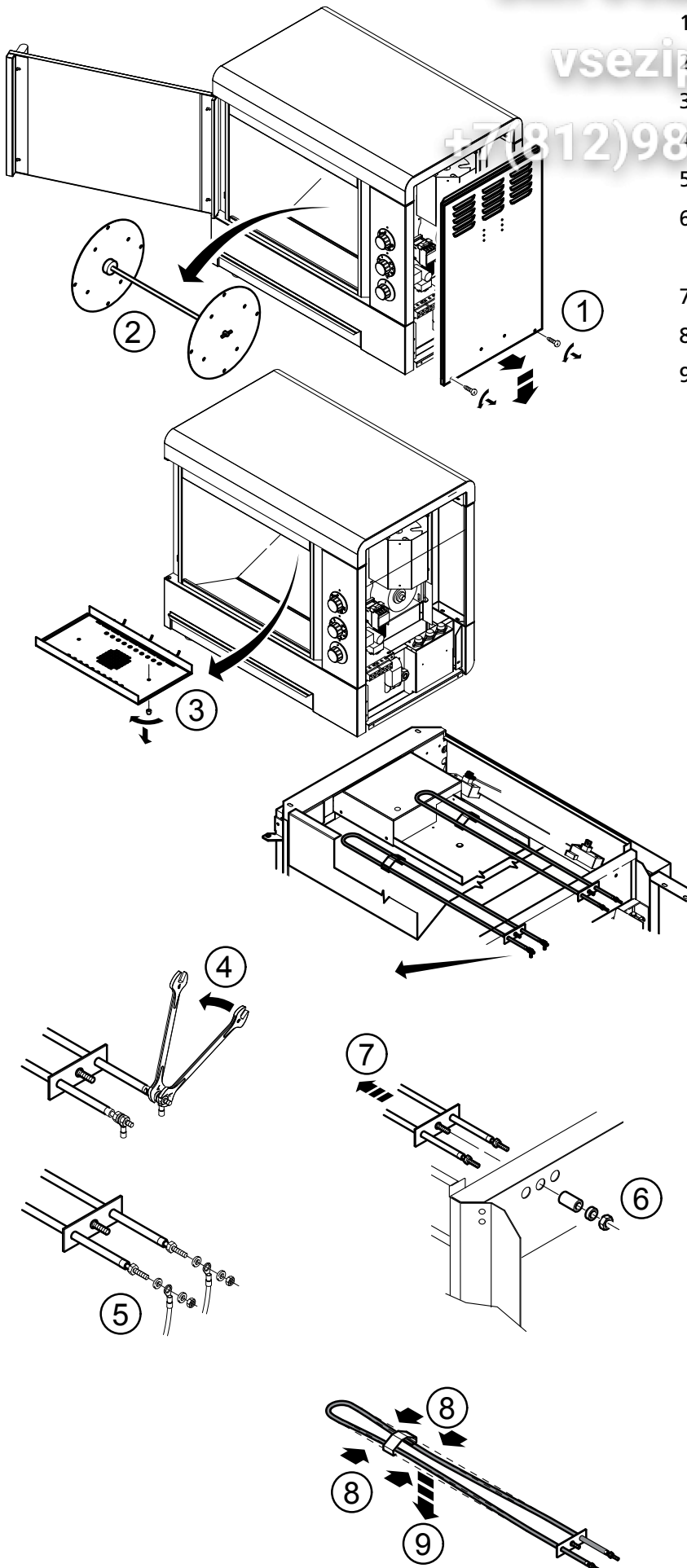

1 Remove the side panel.

2 Remove the rotor.

3 Remove the blower panel.

4 Unscrew the connection nuts.

5 Take off the wires.

6 Unscrew the suspension nut and take care of the spacer.

7 Slide the heating element inwards.

8 Bend the rods towards each other.

9 Move the heating element downwards out of the suspension clip.

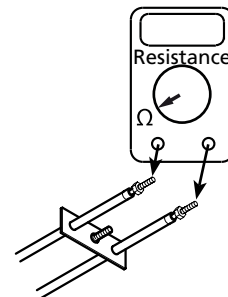

Part nr.	Power / Volt	Ω	Comment
9175008	900W 230V	59 Ω	SB Only
9040015	1,5 kW 230V	35 Ω	230V version
9040625	1,5 kW 208V	29 Ω	208V version

- 1 Remove the rotor
- 2 Remove the side panel
- 3 Remove the Air guide
- 4 Loosen the screw and remove the fan blade
- 5 Disconnect the motor from the terminal block.
- 6 Remove the motor

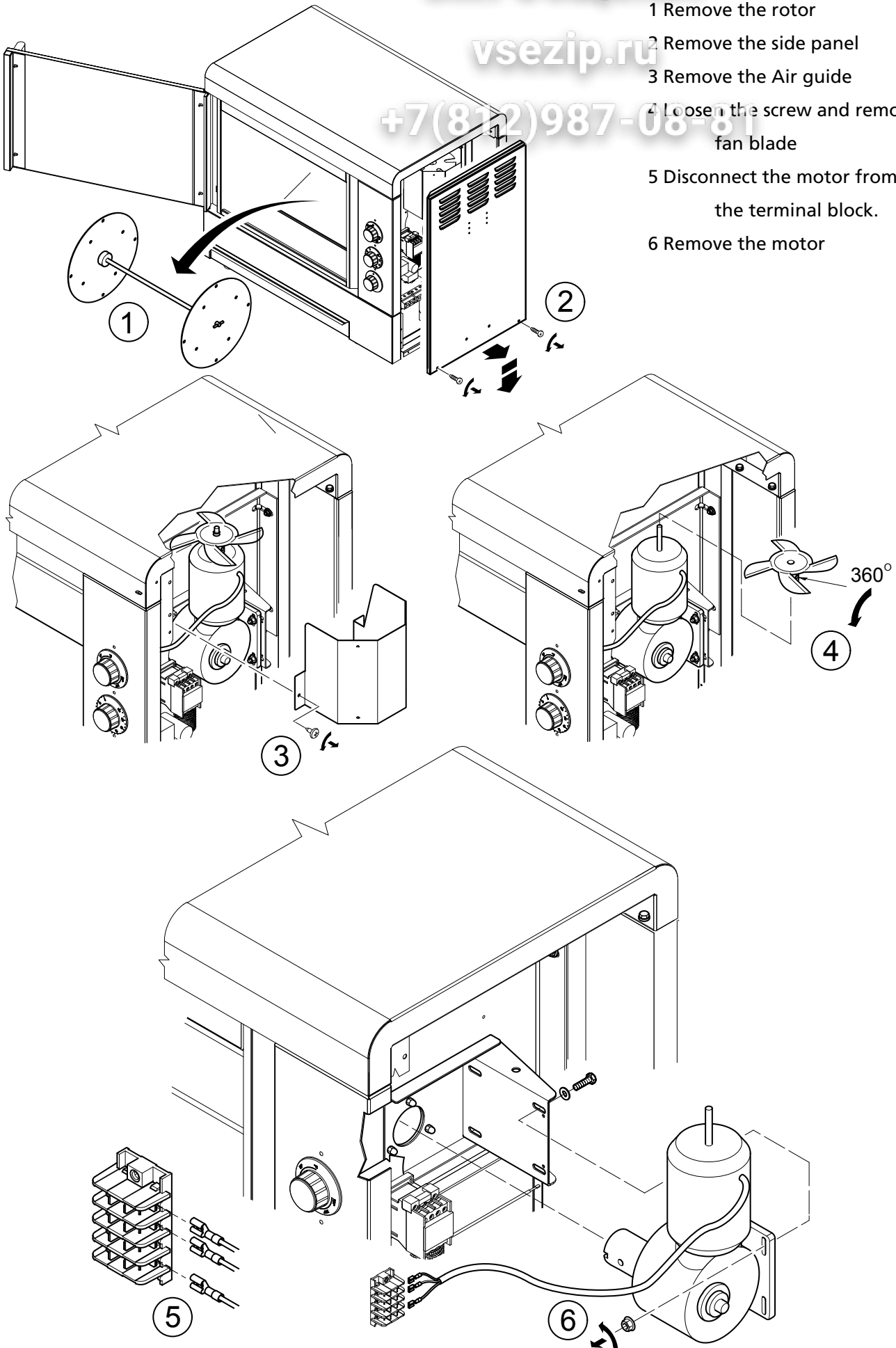

Electrical information.

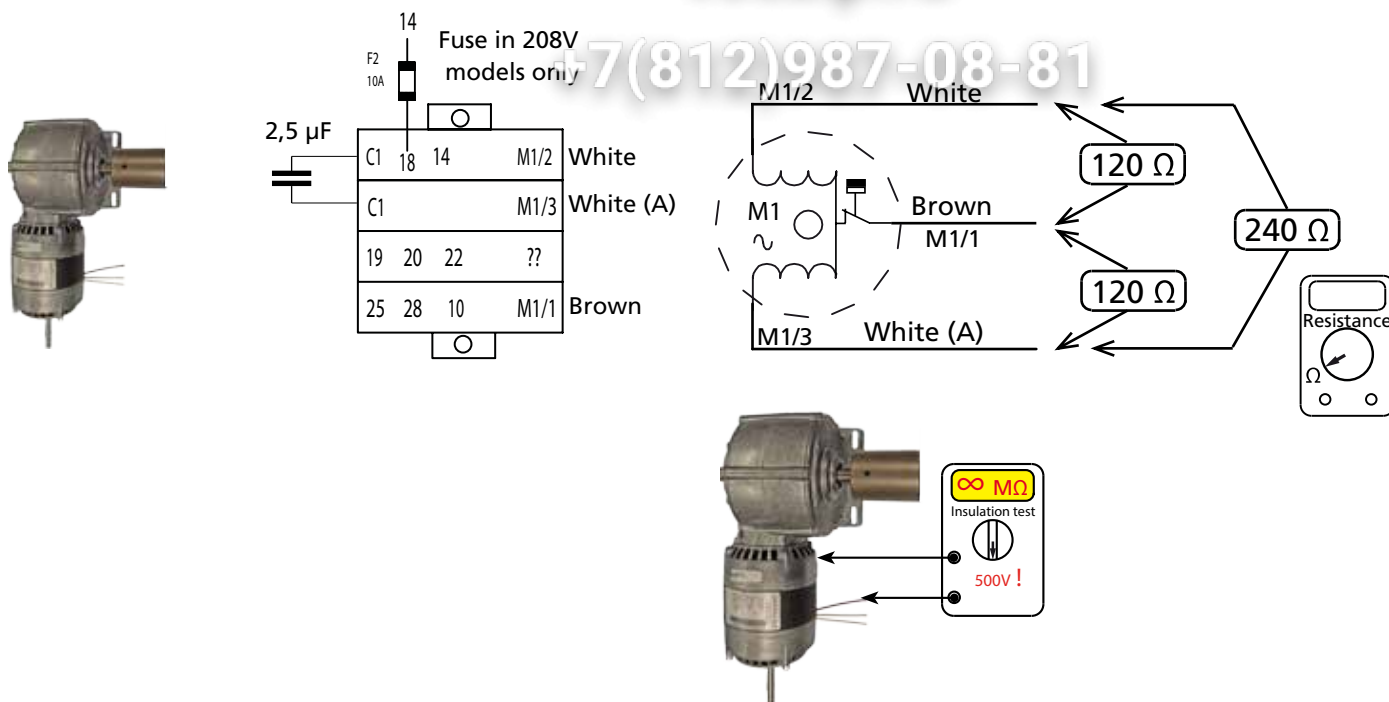

In TG 110 models only.

208V models untill serial number 100041311

230V models untill serial number 100071216

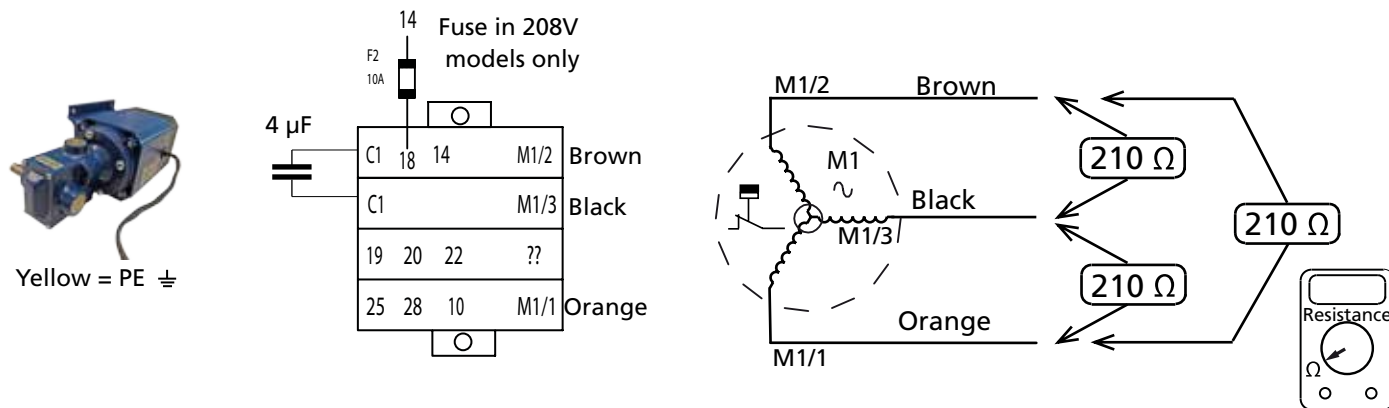

3 ил. Общепит
vsezip.ru
+7(812)987-08-81

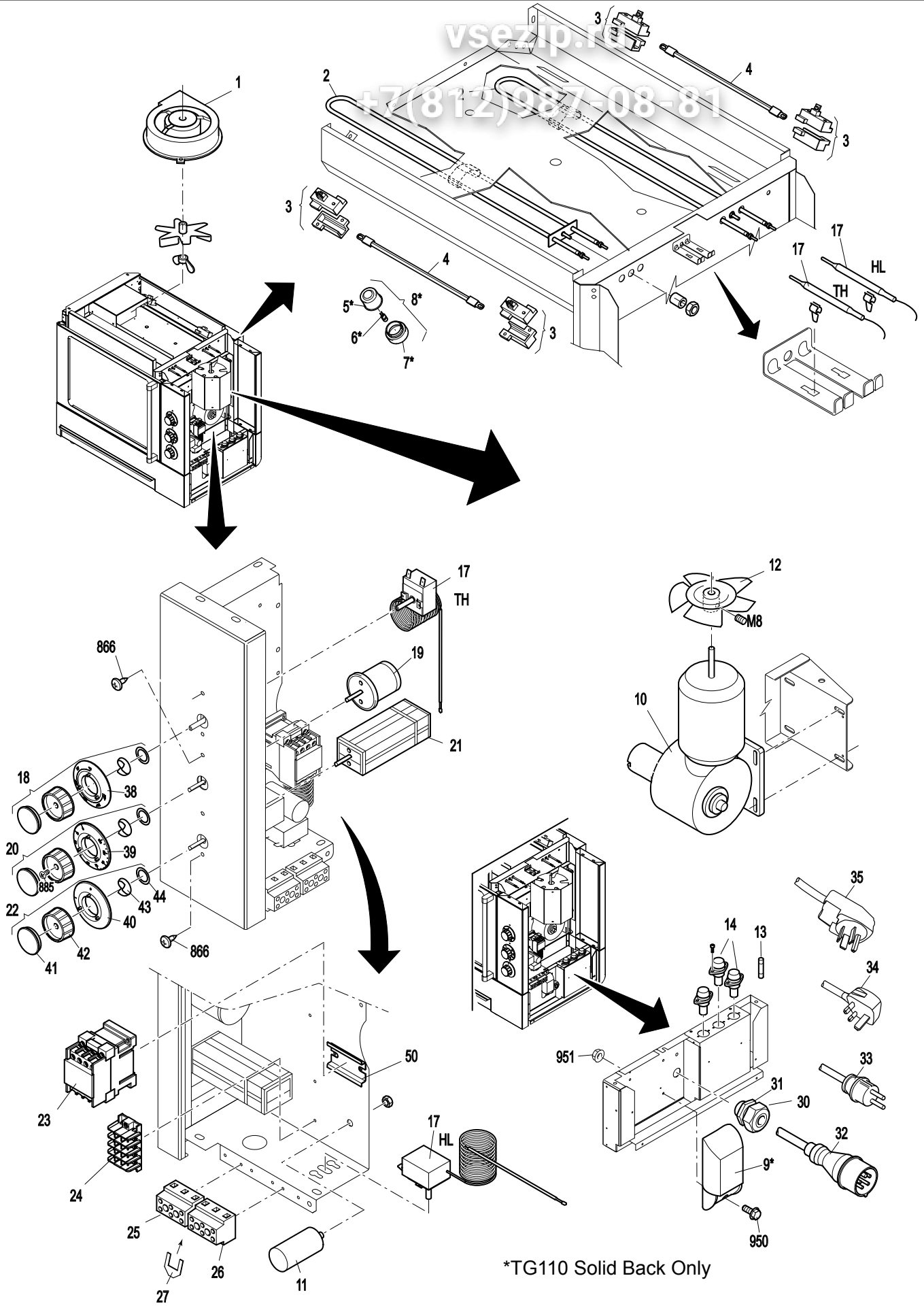

*TG110 Solid Back Only

TG110 AND TG4, PARTSLIST ELECTRICAL PARTS

Pos	part nr.	Description	Qty	Unit	Priority	Comment
1	9070581	Fan G2S150AB56.42 XD 230V 60Hz wire 550mm	1	pc	1	Thermistor protected. 208V models only
1	9070125	Fan G2S150AB08 43 50 Hz 220V wire 550mm	1	pc	1	
2	9175008	Heating element 900W 230V	2	pc	1	Only in Solid Back
2	9040015	Heating element 1,5 kW 230V	2	pc	1	only in Pass Through
2	9040625	Heating element 1,5 kW 208V	2	pc	1	USA & JPN only
3	9110023	Lamp holder quartz lamp	2	pc	2	
4	9056082	Quartz lamp 1000W 220...250V infra-red IRKL	1	pc	1	
5	9171135	Lamp holder excl. Glass	5	pc		Only in Solid Back
6	3701052	Lamp halogen 20W	5	pc		Only in Solid Back
7	9171136	Glass-pane for lampholder	5	pc		Only in Solid Back
8	9171135s	Lamp holder incl. glass	5	pc	2	TG110 SB only
9	3701026	Transformator halogeen HTM 105 230/240 Vac	1	pc	2	Only in Solid Back
10	9173005	Drive motor 1,5 RPM (from serial number 100071217)	1	pc	1	
11	9077101	Capacitor 2,5 µF	1	pc	1	
12	9172078	Blade fan 150 mm for STG	1	pc		
17	9070531	Thermostat 50-250°C, 1-pole	2	pc	1	
18	9178508s	Knob, thermostat, ass.			2	
19	9040463	Clock MI2R 107 120 MN	1	pc	1	
20	9178506s	Knob, Timer switch, ass			2	
21	9172056	Switch main	1	pc		
22	9178507s	Knob, Main switch, ass			2	
23	3500069	Contacto ABB A-09-40-00 230V	1	pc	2	
24	9040374	Terminal block 4-pole OK501-4 ABC	1	pc		
25	9044564	Terminal block G10/3 1-2-3, polyamide	1	pc		
26	9044572	Terminal block G10/3 4-5-6, polyamide	1	pc		
27	9044580	Jumper copper, G10/3 block	4	pc		
30	9222076	Strain relief M20	1	pc		Only in Solid Back
30	9261022	Cable gland M25	1	pc		only in Pass Through
31	9222077	Nut for cable gland	1	pc		Only in Solid Back
31	9261023	Nut for cable gland	1	pc		only in Pass Through
32	9070028	Power cord L=3m H07RN-F 5G2,5 QMM zwart	1	pc		only in Pass Through
33	9091383	Power cord length 3 m black	1	pc		Only in Solid Back
34	3501008	Mains supply cable for UK 13Amp	1	pc		Only in United Kingdom
35	9172403	Power cord L=100inch type 15-20P	1	pc		Only in USA and Japan
38	9172298	Knob rear plate, 250°C	1	pc		
39	9172296	Knob rear plate, 120 min.	1	pc		
40	9172297	Knob rear plate	1	pc		
41	9172050	Cover knob	3	pc		
42	9172022	Knob control	3	pc		
43	9172052	Anti-rotation ring for control knob	3	pc		
44	9110802	Seal 403C silicone 80+/-5C shore	3	pc		
50	9077088	Rail mounting, for magnetic switch	1	pc		

800 -999 => For Fasteners, see next pages

Зип Общепит
TG110, DOORS

vsezip.ru

+7(812)987-08-81

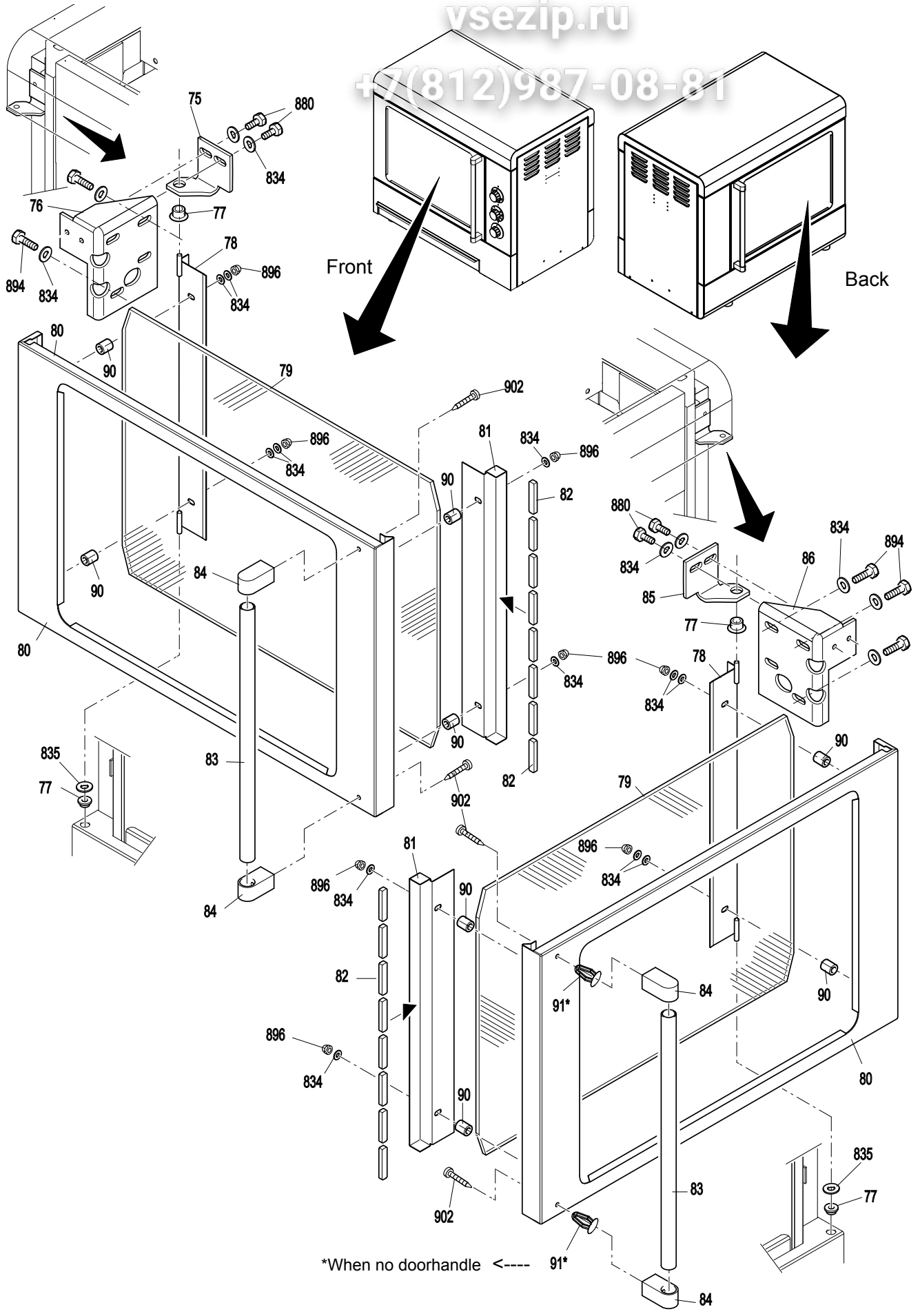

Зип Общепит

TG110, PARTSLIST DOORS

Pos	part nr.	Description	Qty SB	Qty PT	Unit	Priority	Comment
75	9175096	Plate hinge, door	1	1	pc		
76	9175094	Plate hinge, cabinet	1	1	pc		
77	0602072	Collar bearing 6/10 x 6 brass	2	4	pc		
78	9045099	Pin hinge, angle	1	2	pc		
79	9077054	Glass-pane	1	2	pc		
80	9048518	Door operator side	1	2	pc		
81	9041053	Holder magnetic block	1	2	pc		
82	9040081	Magnet 50x9x6 mm	8	16	pc		
83	9040243	Handle	1	2	pc		1 if ST
84	9040031	Base for handle	2	4	pc		2 if ST
85	9175151	Plate hinge, back door	0	1	pc		
86	9175150	Plate hinge, back cabinet	0	1	pc		
90	0018647	Spacer drawing 001.8647 8mm	4	8	pc		
91	9044378	Pressure-nail 615 T=2-6,5 D=12 H=2,0 zwart	0	0	pc		2 if ST

PT: 2 Doors 2 handles

ST: 2 Doors 1 handle

SB: 1 Door 1 handle

Fasteners

Pos	Part number	Description	Qty
800	4280107	Bolt M6x20 ZP	
801	4289559	Washer serrated lock,ext. teeth DIN 6798, M6x0,6 galv.	
804	4285092	Nut hexagon self-locking	
805	4288232	Screw mushroom head, with flange M5x12, A2	
812	9087570	Nut hexagon, tenziloc DIN 985 M5, galv.	
829	4280558	Screw M5x16, SS Slotted wide head	
833	0142307	Nut M4, SS	
834	4311110	Washer plain, d2 ~ 3 x d1 SS A2 DIN 9021 M5x1,2, A2	
835	0142111	Washer plain DIN 125 M6x1,6, A2	
837	0195910	Nut hexagon domed cap, brass, nickel plated DIN 1587 M6	
847	9070688	Screw hexagon head DIN 933 M8x12, A2	
864	4285319	Screw hexagon head, drilling, collar DIN 7504, 4,8x13, galv.	
866	4287620	Screw pan head tapping, Philips DIN 7981, 4,2x13, nickle pl.	
877	4285135	Screw taptite, hexagon head flange DIN 7500, M5x10, galv.	
880	9008178	Screw hexagon head DIN 933 M5x8, A2	
881	0141246	Screw hexagon head M6x12, A2	
885	4288324	Screw button head M4x8, A2	

Pos	Part number	Description	Qty
888	6962153	Washer mudwing repair M6x1,5, Elec. Galv. Steel	
890	9172053	Nut-plate 14079 M5 zi.s	
894	0211520	Screw hexagon head M5x12	
895	0144359	Locknut M5, SS	
896	4285408	Nut hexagon domed cap DIN 1587 M5x10, Brass nickle plated	
898	9073987	Washer M8, SS ø8xØ25	
902	4288319	Screw taptite pan head, Pozidriv, M6x20, galv.	
908	9006930	Lockwasher M4, countersunk SS serrated	
910	4287520	Washer plain DIN 125 M4x0,8, Mes-sing	
911	4285020	Nut hexagon DIN 934 M4x3,2, Brass Cu2/Cu3	
915	8047381	Washer mudwing repair M6x1,5, A2	
936	9073149	Nut wing nut M6, A2	2
946	4286728	Screw , socket head cap DIN 916	
949	0142975	Screw socket head cap M6x20, A2	6
950	4285120	Screw taptite, thread rolling DIN 7500	
951	8071043	Nut hexagon flange, knurled	
952	6962187	Washer mudwing repair M8x1,5, Elec. Galv. Steel	
953	0197807	Screw cheese head M4x30 galv.	

Зип Общепит
TG4, DOORS

vsezip.ru

+7(812)987-08-81

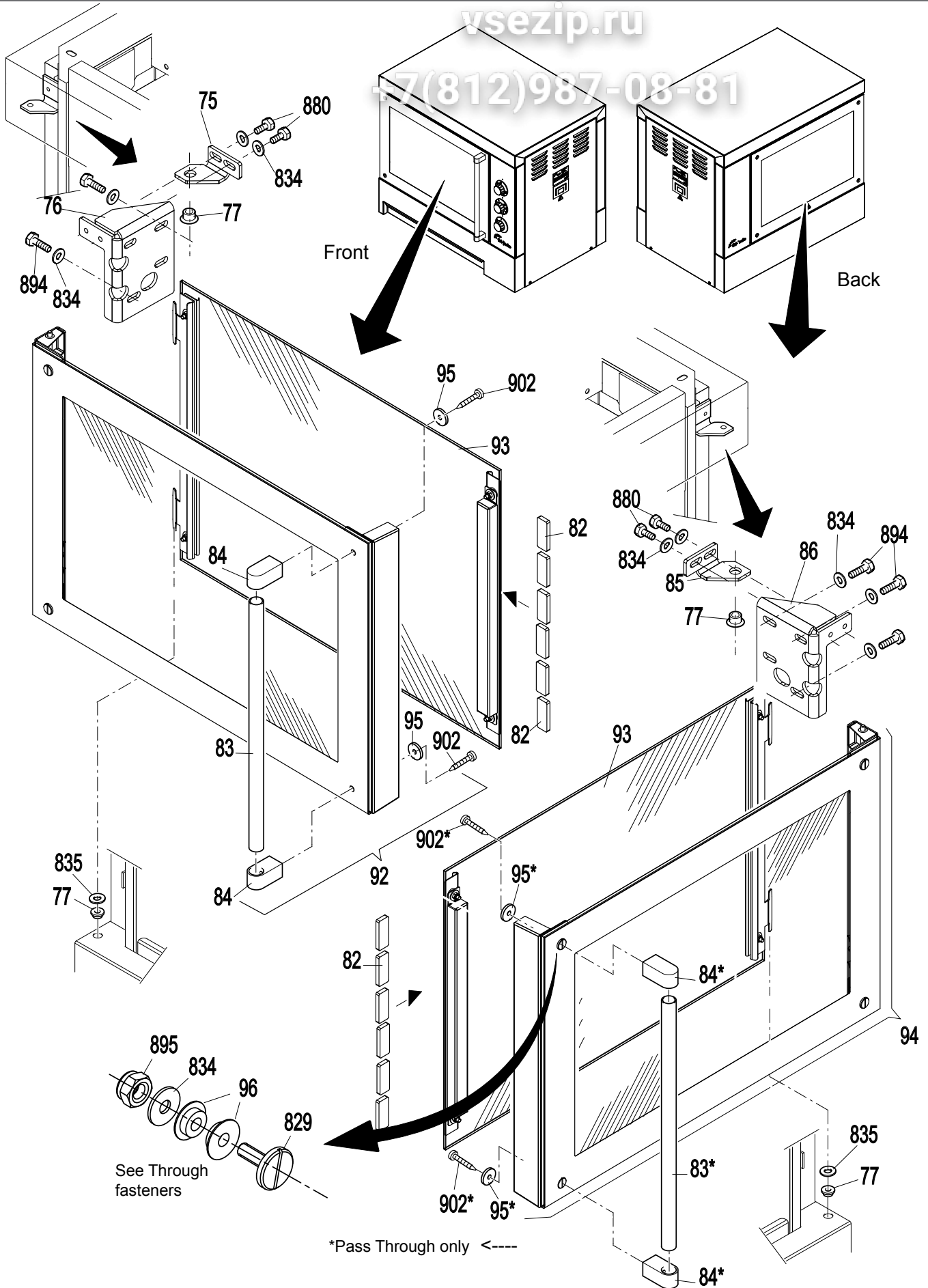

Зип Общепит

TG4, PARTSLIST DOORS

Pos	part nr.	Description	Qty SB	Qty PT	Unit	Priority	Comment
75	9175272	Hinge top	1	1	pc		
76	9175273	Hinge top, casco	1	1	pc		
77	0602072	Collar bearing 6/10 x 6 brass	2	4	pc		
82	9070141	Magnet 50x19x6 mm	6	12	pc		
83	9040243	Handle	1	2	pc		1 if PT
84	9040031	Base for handle	2	4	pc		2 if PT
85	9175275	Hinge top, back	0	1	pc		
86	9175276	Hinge top, casco back	0	1	pc		
92	9178313s	Ass. Outer Door TG-4M PT	1	2	pc		
93	9178304s	Ass. Inner Door TG-4M	1	2	pc		
94	9178303s	Ass. Outer Door TG-4M ST	1	2	pc		
96	3702342	Collar bush, PTFE 10x5x3,5	4	4	pc	1	
95	9174680	Washer ø5,2xØ20	2	4	pc		2 if PT

PT: 2 Doors 2 handles

ST: 2 Doors 1 handle

SB: 1 Door 1 handle

Fasteners

Pos	Part number	Description	Qty
800	4280107	Bolt M6x20 ZP	
801	4289559	Washer serrated lock, ext. teeth DIN 6798, M6x0,6 galv.	
804	4285092	Nut hexagon self-locking	
805	4288232	Screw mushroom head, with flange M5x12, A2	
812	9087570	Nut hexagon, tenziloc DIN 985 M5, galv.	
829	4280558	Screw M5x16, SS Slotted wide head	
833	0142307	Nut M4, SS	
834	4311110	Washer plain, d2 ~ 3 x d1 SS A2 DIN 9021 M5x1,2, A2	
835	0142111	Washer plain DIN 125 M6x1,6, A2	
837	0195910	Nut hexagon domed cap, brass, nickel plated DIN 1587 M6	
847	9070688	Screw hexagon head DIN 933 M8x12, A2	
864	4285319	Screw hexagon head, drilling, collar DIN 7504, 4,8x13, galv.	
866	4287620	Screw pan head tapping, Philips DIN 7981, 4,2x13, nickle pl.	
877	4285135	Screw taptite, hexagon head flange DIN 7500, M5x10, galv.	
880	9008178	Screw hexagon head DIN 933 M5x8, A2	
881	0141246	Screw hexagon head M6x12, A2	
885	4288324	Screw button head M4x8, A2	

Pos	Part number	Description	Qty
888	6962153	Washer mudwing repair M6x1,5, Elec. Galv. Steel	
890	9172053	Nut-plate 14079 M5 zi.s	
894	0211520	Screw hexagon head M5x12	
895	0144359	Locknut M5, SS	
896	4285408	Nut hexagon domed cap DIN 1587 M5x10, Brass nickle plated	
898	9073987	Washer M8, SS ø8xØ25	
902	4288319	Screw taptite pan head, Pozidriv, M6x20, galv.	
908	9006930	Lockwasher M4, countersunk SS serrated	
910	4287520	Washer plain DIN 125 M4x0,8, Messing	
911	4285020	Nut hexagon DIN 934 M4x3,2, Brass Cu2/Cu3	
915	8047381	Washer mudwing repair M6x1,5, A2	
936	9073149	Nut wing nut M6, A2	2
946	4286728	Screw , socket head cap DIN 916	
949	0142975	Screw socket head cap M6x20, A2	6
950	4285120	Screw taptite, thread rolling DIN 7500	
951	8071043	Nut hexagon flange, knurled	
952	6962187	Washer mudwing repair M8x1,5, Elec. Galv. Steel	
953	0197807	Screw cheese head M4x30 galv.	

Зип Общепит
TG110 AND TG4, ILLUMINATION

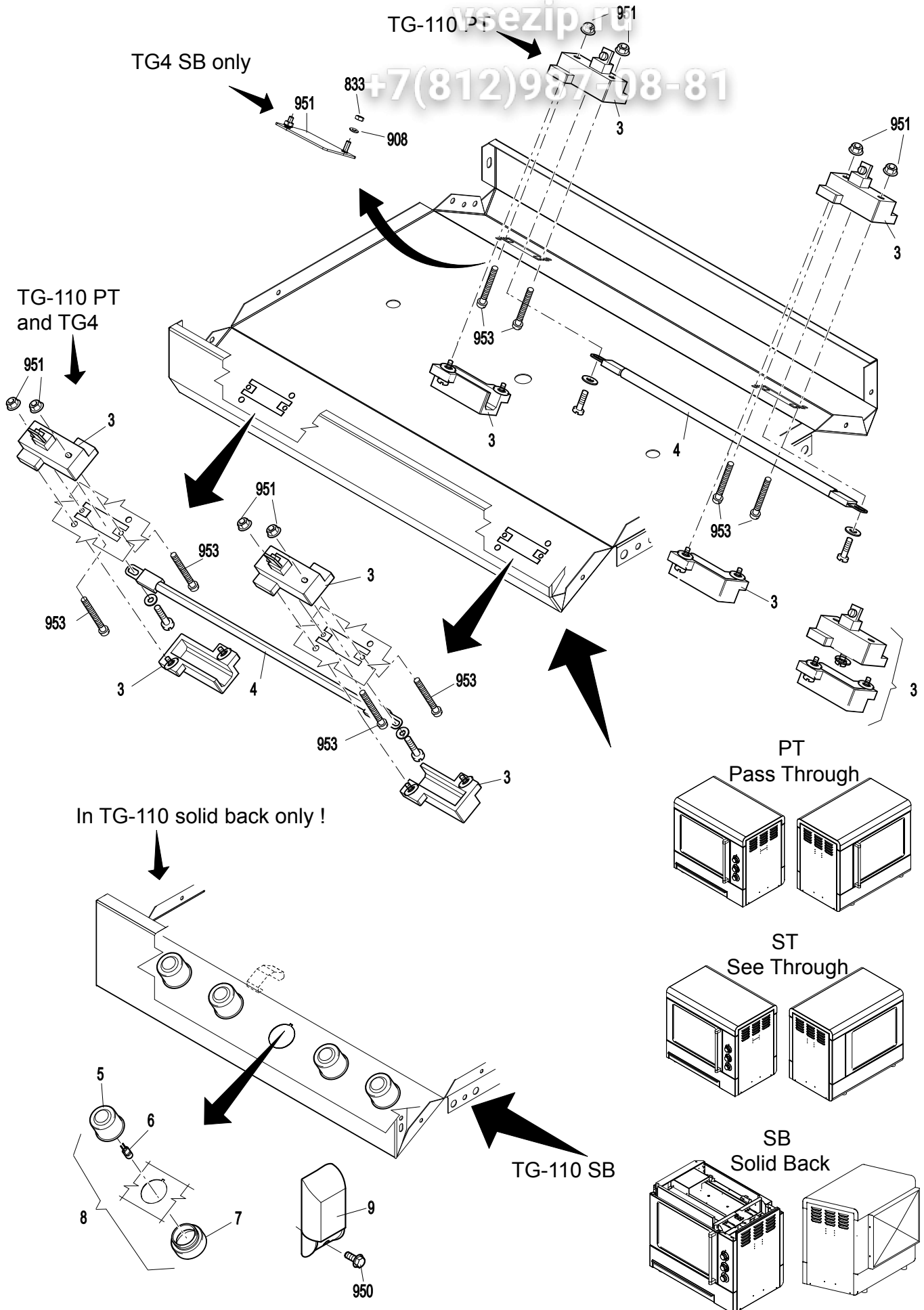

Зип Общепит

TG110 AND TG4, PARTSLIST ILLUMINATION

Pos	part nr.	Description	Qty	Unit	Priority	Comment
3	9110023	Lamp holder quartz lamp	2	pc	2	
4	9056082	Quartz lamp 1000W 220...250V infra-red IR K...	1	pc		
5	9171135	Lamp holder excl. Glass	5	pc		Only in SB
6	3701052	Lamp halogen 20W	5	pc		Only in SB
7	9171136	Glass-pane for lampholder	5	pc		Only in SB
8	9171135s	Lamp holder incl. glass	5	pc	2	Only in SB
9	3701026	Transformator halogeen HTM 105 230/240 Vac	1	pc	2	Only in SB
49	9175291	Cover plate, hole	2	pc		Only in SB

Fasteners

Pos	Part number	Description	Qty
800	4280107	Bolt M6x20 ZP	
801	4289559	Washer serrated lock,ext. teeth DIN 6798, M6x0,6 galv.	
804	4285092	Nut hexagon self-locking	
805	4288232	Screw mushroom head, with flange M5x12, A2	
812	9087570	Nut hexagon, tenziloc DIN 985 M5, galv.	
829	4280558	Screw M5x16, SS Slotted wide head	
833	0142307	Nut M4, SS	
834	4311110	Washer plain, d2 ~ 3 x d1 SS A2 DIN 9021 M5x1,2, A2	
835	0142111	Washer plain DIN 125 M6x1,6, A2	
837	0195910	Nut hexagon domed cap, brass, nickel plated DIN 1587 M6	
847	9070688	Screw hexagon head DIN 933 M8x12, A2	
864	4285319	Screw hexagon head, drilling, collar DIN 7504, 4,8x13, galv.	
866	4287620	Screw pan head tapping, Philips DIN 7981, 4,2x13, nickle pl.	
877	4285135	Screw taptite, hexagon head flange DIN 7500, M5x10, galv.	
880	9008178	Screw hexagon head DIN 933 M5x8, A2	
881	0141246	Screw hexagon head M6x12, A2	
885	4288324	Screw button head M4x8, A2	

Pos	Part number	Description	Qty
888	6962153	Washer mudwing repair M6x1,5, Elec. Galv. Steel	
890	9172053	Nut-plate 14079 M5 zi.s	
894	0211520	Screw hexagon head M5x12	
895	0144359	Locknut M5, SS	
896	4285408	Nut hexagon domed cap DIN 1587 M5x10, Brass nickle plated	
898	9073987	Washer M8, SS ø8xØ25	
902	4288319	Screw taptite pan head, Pozidriv, M6x20, galv.	
908	9006930	Lockwasher M4, countersunk SS serrated	
910	4287520	Washer plain DIN 125 M4x0,8, Messing	
911	4285020	Nut hexagon DIN 934 M4x3,2, Brass Cu2/Cu3	
915	8047381	Washer mudwing repair M6x1,5, A2	
936	9073149	Nut wing nut M6, A2	2
946	4286728	Screw , socket head cap DIN 916	
949	0142975	Screw socket head cap M6x20, A2	6
950	4285120	Screw taptite, thread rolling DIN 7500	
951	8071043	Nut hexagon flange, knurled	
952	6962187	Washer mudwing repair M8x1,5, Elec. Galv. Steel	
953	0197807	Screw cheese head M4x30 galv.	

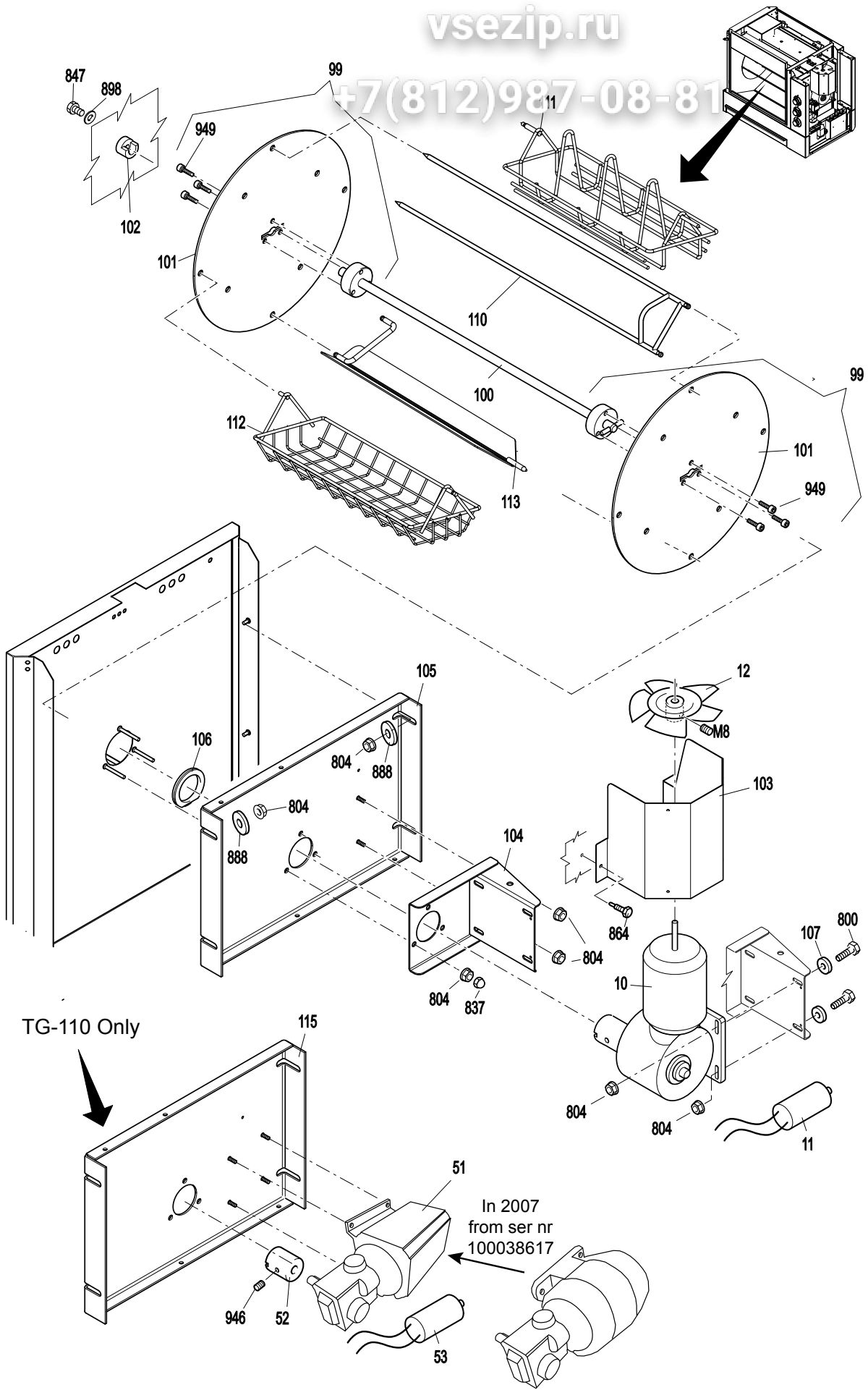

TG-110 Only

In 2007
from ser nr
100038617

TG110 AND TG4, PARTSLIST ROTOR

Pos	part nr.	Description	Qty	Unit	Priority	Comment
10	9173005	Drive motor 1,5 RPM (from serial number 100071217)	1	pc	1	
11	9077101	Capacitor 2,5 µF	1	pc	1	
12	9172078	Blade fan 150 mm for STG	1	pc	1	
51	9070565	Drive motor (untill serial number 100071216)	1	pc		TG-110 only
52	9070206	Drive head (untill serial number 100071216)	1	pc		TG-110 only
53	9171084	Capacitor 4µF				TG-110 only
99	9040154	Rotor ass., coated				
100	9170571	Rotor shaft, welding ass.	1	pc		
100	9172250	Rotor shaft coated, welding ass.				
101	9175000	Rotor disc 3 mm / 4-spits	2	pc		
101	9175016	Rotor disc coated, 3 mm / 4-spits				
102	9172062	Axle support 12mm	1	pc		
103	9174753	Cover fan	1	pc		
104	9170656	Ass. motorsupport	1	pc		
105	9174749	Mounting plate engine	1	pc		
106	9073131	Ring-Virgin-PTFE 62 x 45 x 6 mm VLG	1	pc		
107	9294083	Shim fan	4	pc		
110	9079250	Spit set TG 101 packed per 4 pcs				
110	9010549	Spit double TG101/220, STG 5				
111	9172112	Chickenrack STG5				
112	9010387	Basket TG101/220,STG5				
113	9112472	V-spit TG101/220, STG5				
115	9045073	Mounting plate motor (untill serial number 100071216)				TG-110 only

Fasteners

Pos	Part nr.	Description	Qty	Pos	Part nr.	Description	Qty
800	4280107	Bolt M6x20 ZP		888	6962153	Washer mudwing repair M6x1,5, Elec. Galv. Steel	
801	4289559	Washer serrated lock,ext. teeth DIN 6798, M6x0,6 galv.		890	9172053	Nut-plate 14079 M5 zi.s	
804	4285092	Nut hexagon self-locking		894	0211520	Screw hexagon head M5x12	
805	4288232	Screw mushroom head, with flange M5x12, A2		896	4285408	Nut hexagon domed cap DIN 1587 M5x10, Brass nickle plated	
812	9087570	Nut hexagon, tenziloc DIN 985 M5, galv.		898	9073987	Washer M8, SS ø8xØ25	
833	0142307	Nut M4, SS		902	4288319	Screw taptite pan head, Pozidriv, M6x20, galv.	
834	4311110	Washer plain, d2 ~ 3 x d1 SS A2 DIN 9021 M5x1,2, A2		908	9006930	Lockwasher M4, countersunk SS serrated	
835	0142111	Washer plain DIN 125 M6x1,6, A2		910	4287520	Washer plain DIN 125 M4x0,8, Messing	
837	0195910	Nut hexagon domed cap, brass, nickel plated DIN 1587 M6		911	4285020	Nut hexagon DIN 934 M4x3,2, Brass Cu2/ Cu3	
847	9070688	Screw hexagon head DIN 933 M8x12, A2		915	8047381	Washer mudwing repair M6x1,5, A2	
864	4285319	Screw hexagon head, drilling, collar DIN 7504, 4,8x13, galv.		936	9073149	Nut wing nut M6, A2	2
866	4287620	Screw pan head tapping, Philips DIN 7981, 4,2x13, nickle pl.		946	4286728	Screw , socket head cap DIN 916	
877	4285135	Screw taptite, hexagon head flange DIN 7500, M5x10, galv.		949	0142975	Screw socket head cap M6x20, A2	6
880	9008178	Screw hexagon head DIN 933 M5x8, A2		950	4285120	Screw taptite, thread rolling DIN 7500	
881	0141246	Screw hexagon head M6x12, A2		951	8071043	Nut hexagon flange, knurled	
885	4288324	Screw button head M4x8, A2		952	6962187	Washer mudwing repair M8x1,5, Elec. Galv. Steel	
				953	0197807	Screw cheese head M4x30 galv.	

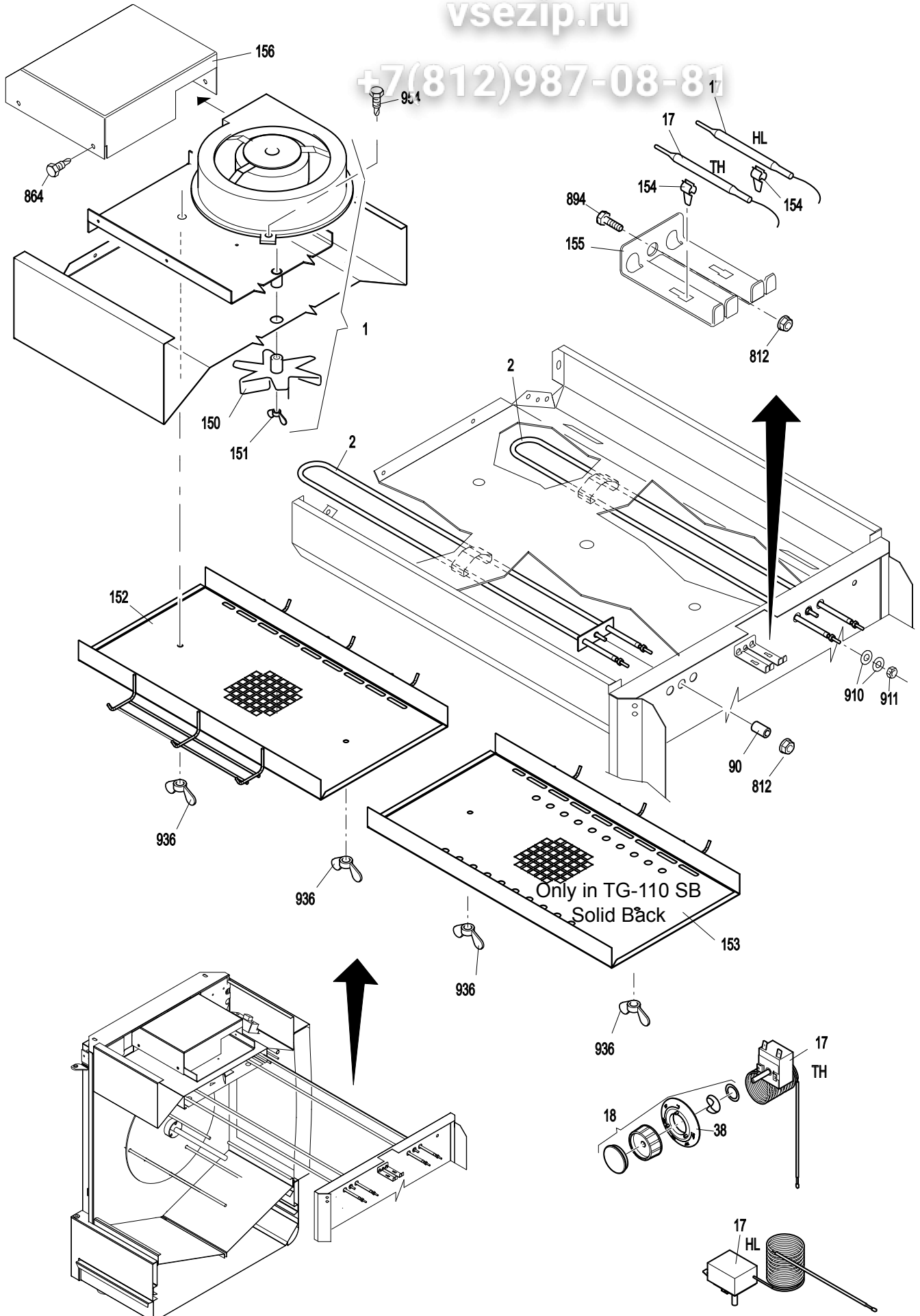

Зип Общепит

TG110 AND TG4, PARTSLIST HEATING

Pos	part nr.	Description	Qty	Unit	Priority	Comment
1	9070581	Fan G2S150AB56.42 XD 230V 60Hz wire 550mm	1	pc	1	Thermistor protected. 208V models only.
1	9070125	Fan G2S150AB08 43 50 Hz 220V wire 550mm	1	pc	1	
2	9175008	Heating element 900W 230V	2	pc	1	Only in Solid Back
2	9040015	Heating element 1,5 kW 230V	2	pc	1	only in Pass Through
2	9040625	Heating element 1,5 kW 208V	2	pc	1	USA & JPN only
17	9070531	Thermostat 50-250°C, 1-pole	2	pc	1	
18	9178508s	Knob, thermostat, ass.			2	
150	9110153	Fan blade	1	pc		
151	9073150	Nut wing nut Din 315 M6, left threaded	1	pc		
152	9045188	Air guide plate	1	pc		TG-110 PT + TG-4
153	9045190	Air guide plate	1	pc		TG-110 SB only
154	9110072	Cable clamp 11503-100-300 ZI-GE	2	pc		
155	9294067	Mounting plate sensors	1	pc		
156	9041354	Air channel	1	pc		

Fasteners

Pos	Part number	Description	Qty
800	4280107	Bolt M6x20 ZP	
801	4289559	Washer serrated lock, ext. teeth DIN 6798, M6x0,6 galv.	
804	4285092	Nut hexagon self-locking	
805	4288232	Screw mushroom head, with flange M5x12, A2	
812	9087570	Nut hexagon, tenziloc DIN 985 M5, galv.	
829	4280558	Screw M5x16, SS Slotted wide head	
833	0142307	Nut M4, SS	
834	4311110	Washer plain, d2 ~ 3 x d1 SS A2 DIN 9021 M5x1,2, A2	
835	0142111	Washer plain DIN 125 M6x1,6, A2	
837	0195910	Nut hexagon domed cap, brass, nickel plated DIN 1587 M6	
847	9070688	Screw hexagon head DIN 933 M8x12, A2	
864	4285319	Screw hexagon head, drilling, collar DIN 7504, 4,8x13, galv.	
866	4287620	Screw pan head tapping, Philips DIN 7981, 4,2x13, nickle pl.	
877	4285135	Screw taptite, hexagon head flange DIN 7500, M5x10, galv.	
880	9008178	Screw hexagon head DIN 933 M5x8, A2	
881	0141246	Screw hexagon head M6x12, A2	
885	4288324	Screw button head M4x8, A2	

Pos	Part number	Description	Qty
888	6962153	Washer mudwing repair M6x1,5, Elec. Galv. Steel	
890	9172053	Nut-plate 14079 M5 zi.s	
894	0211520	Screw hexagon head M5x12	
895	0144359	Locknut M5, SS	
896	4285408	Nut hexagon domed cap DIN 1587 M5x10, Brass nickle plated	
898	9073987	Washer M8, SS ø8xØ25	
902	4288319	Screw taptite pan head, Pozidriv, M6x20, galv.	
908	9006930	Lockwasher M4, countersunk SS serrated	
910	4287520	Washer plain DIN 125 M4x0,8, Mes-sing	
911	4285020	Nut hexagon DIN 934 M4x3,2, Brass Cu2/Cu3	
915	8047381	Washer mudwing repair M6x1,5, A2	
936	9073149	Nut wing nut M6, A2	2
946	4286728	Screw , socket head cap DIN 916	
949	0142975	Screw socket head cap M6x20, A2	6
950	4285120	Screw taptite, thread rolling DIN 7500	
951	8071043	Nut hexagon flange, knurled	
952	6962187	Washer mudwing repair M8x1,5, Elec. Galv. Steel	
953	0197807	Screw cheese head M4x30 galv.	

Зип Общепит
TG110 AND TG4, SHEET METAL

vsezip.ru

+7(812)987-08-81

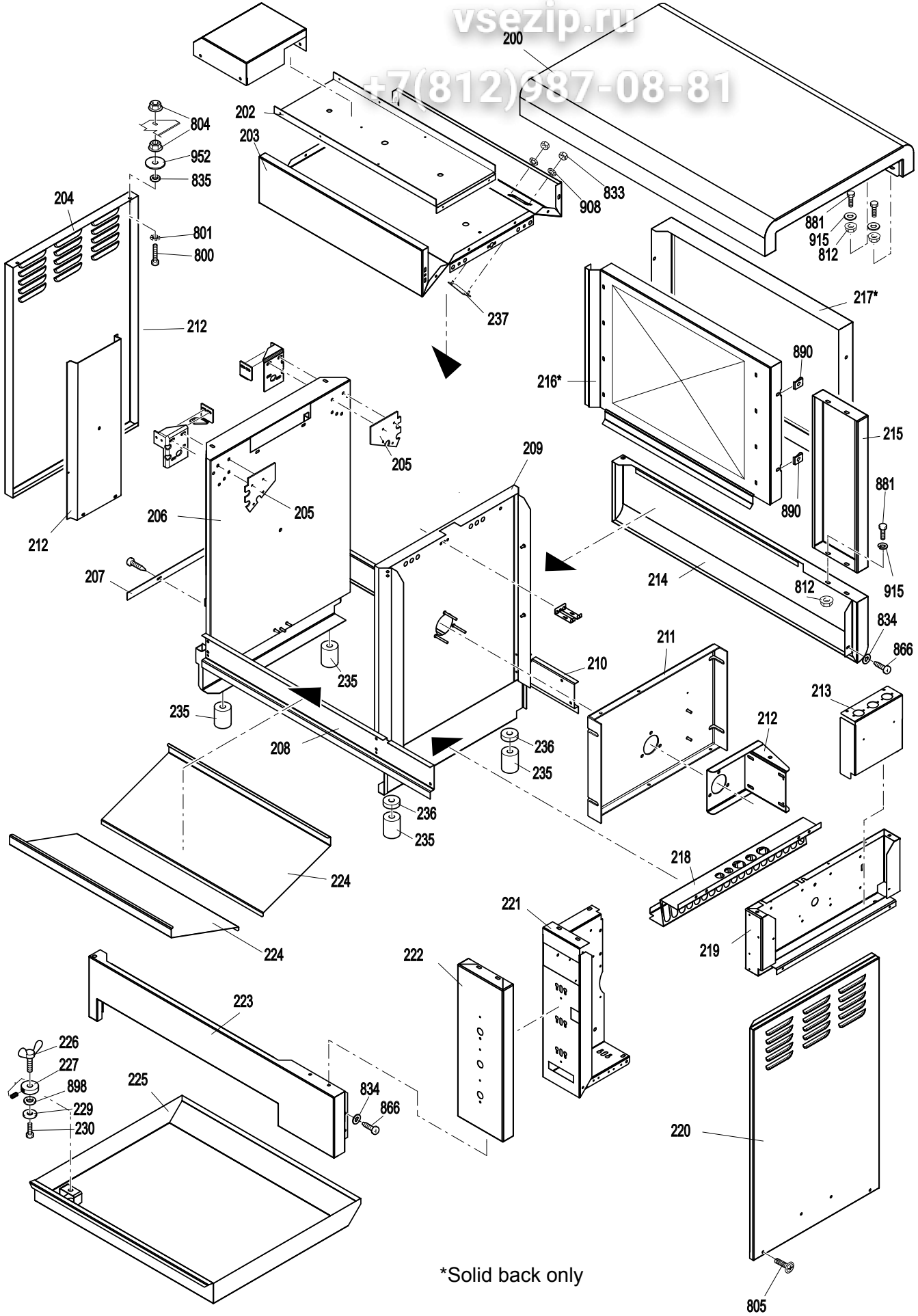

*Solid back only

Зип Общепит

TG110 AND TG4, PARTSLIST SHEET METAL

Pos	part nr.	Description	Qty	Unit	Priority	Comment
200	9045007	Cover plate top	1	pc		Only TG110
200	9175262	Top panel	1	pc		Only TG4
202	9045065	Plate fan	1	pc		
203	9175101	Ceiling Welding ass.	1	pc		TG-110 SB only
203	9041090	Ceiling	1	pc		TG-4 + TG-110 PT
204	9041011	Panel outer, left	1	pc		
205	9175097	Trunnion hinge	2	pc		
206	9045015	Side panel left	1	pc		
207	9041320	Mounting plate insulation	1	pc		
208	9041192	Reinforcement plate operator side bottom	1	pc		
209	9045023	Side panel right	1	pc		
210	9041184	Reinforcement plate customer side	1	pc		
212	9041312	Reinforcement plate bearing	1	pc		
214	9045057	Front bottom, customerside	1	pc		Only TG110
214	9175261	Underframe Bottom, customer side	1	pc		Only TG4
215	9048267	Customer side panel TG 110	1	pc		Only TG110
215	9178308	Ass. Frontpanel TG 4M	1	pc		Only TG4
216	9175024	Back panel inner	1	pc		Only in SB
217	9175025	Back panel	1	pc		Only in SB
219	9041362	Mounting plate	1	pc		
220	9041029	Panel outer, right	1	pc		
221	9045324	Mounting plate electricity	1	pc		Only TG110
221	9175277	Electrical panel	1	pc		Only TG4
222	9048048	Control panel TG 110H	1	pc		Only TG110
222	9178309	Ass. Operation panel TG 4M	1	pc		Only TG4
223	9045049	Front bottom, operatorside	1	pc		Only TG110
223	9175260	Underframe Bottom, operator side	1	pc		Only TG4
224	9041142	Bottom plate	2	pc		
224	9175017	Bottom plate, coated	2	pc		
225	9044815	Drawer TG101	1	pc		
226	9070662	Wing screw M8x30 nickel-plated	1	pc		
227	9070777	Brass disc ø30 with inner hexagon M5x12	1	pc		
229	9070670	Ring viton	1	pc		
230	9070688	Bolt M8x12, SS	1	pc		
235	9082910	Rubber foot ø40 mm h=40 mm	4	pc		
236	9174696	Shim for legs TG110	4	pc		
237	9175291	Cover plate Lighting	2	pc		Only TG-4 SB

800 -999 => For Fasteners, see previous pages

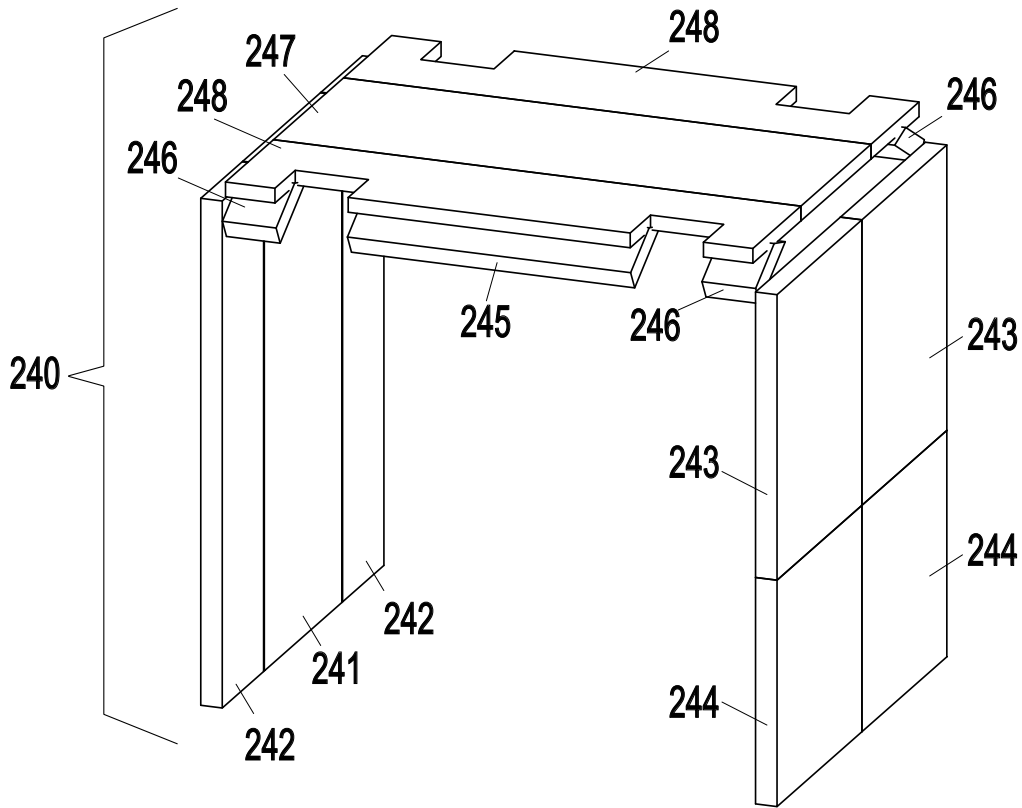

Зип Общепит

TG110 AND TG4, PARTSLIST INSULATION

Pos	part nr.	Description	Qty	Unit	Priority	Comment
240	9040131	Ass. Insulation TG 4M	1	pc		
241	9043113	Insulation left side TG 4M	1	pc		
242	9043112	Insulation left side small TG 4M	2	pc		
243	9043115	Insulation right side above TG 4M	2	pc		
244	9043114	Insulation right side below TG 4M	2	pc		
245	9043118	Insulation Top between lamps	2	pc		
246	9043116	Insulation Top small TG 4M	4	pc		
247	9043119	Insulation Top middle TG 4M	1	pc		
248	9043117	Insulation Top TG 4M	2	pc		

Fasteners

Pos	Part number	Description	Qty
800	4280107	Bolt M6x20 ZP	
801	4289559	Washer serrated lock,ext. teeth DIN 6798, M6x0,6 galv.	
804	4285092	Nut hexagon self-locking	
805	4288232	Screw mushroom head, with flange M5x12, A2	
812	9087570	Nut hexagon, tenziloc DIN 985 M5, galv.	
829	4280558	Screw M5x16, SS Slotted wide head	
833	0142307	Nut M4, SS	
834	4311110	Washer plain, d2 ~ 3 x d1 SS A2 DIN 9021 M5x1,2, A2	
835	0142111	Washer plain DIN 125 M6x1,6, A2	
837	0195910	Nut hexagon domed cap, brass, nickel plated DIN 1587 M6	
847	9070688	Screw hexagon head DIN 933 M8x12, A2	
864	4285319	Screw hexagon head, drilling, collar DIN 7504, 4,8x13, galv.	
866	4287620	Screw pan head tapping, Philips DIN 7981, 4,2x13, nickle pl.	
877	4285135	Screw taptite, hexagon head flange DIN 7500, M5x10, galv.	
880	9008178	Screw hexagon head DIN 933 M5x8, A2	
881	0141246	Screw hexagon head M6x12, A2	
885	4288324	Screw button head M4x8, A2	

Pos	Part number	Description	Qty
888	6962153	Washer mudwing repair M6x1,5, Elec. Galv. Steel	
890	9172053	Nut-plate 14079 M5 zi.s	
894	0211520	Screw hexagon head M5x12	
895	0144359	Locknut M5, SS	
896	4285408	Nut hexagon domed cap DIN 1587 M5x10, Brass nickle plated	
898	9073987	Washer M8, SS ø8xØ25	
902	4288319	Screw taptite pan head, Pozidriv, M6x20, galv.	
908	9006930	Lockwasher M4, countersunk SS serrated	
910	4287520	Washer plain DIN 125 M4x0,8, Mes-sing	
911	4285020	Nut hexagon DIN 934 M4x3,2, Brass Cu2/Cu3	
915	8047381	Washer mudwing repair M6x1,5, A2	
936	9073149	Nut wing nut M6, A2	2
946	4286728	Screw , socket head cap DIN 916	
949	0142975	Screw socket head cap M6x20, A2	6
950	4285120	Screw taptite, thread rolling DIN 7500	
951	8071043	Nut hexagon flange, knurled	
952	6962187	Washer mudwing repair M8x1,5, Elec. Galv. Steel	
953	0197807	Screw cheese head M4x30 galv.	

vsezip.ru
+7(812)987-08-81

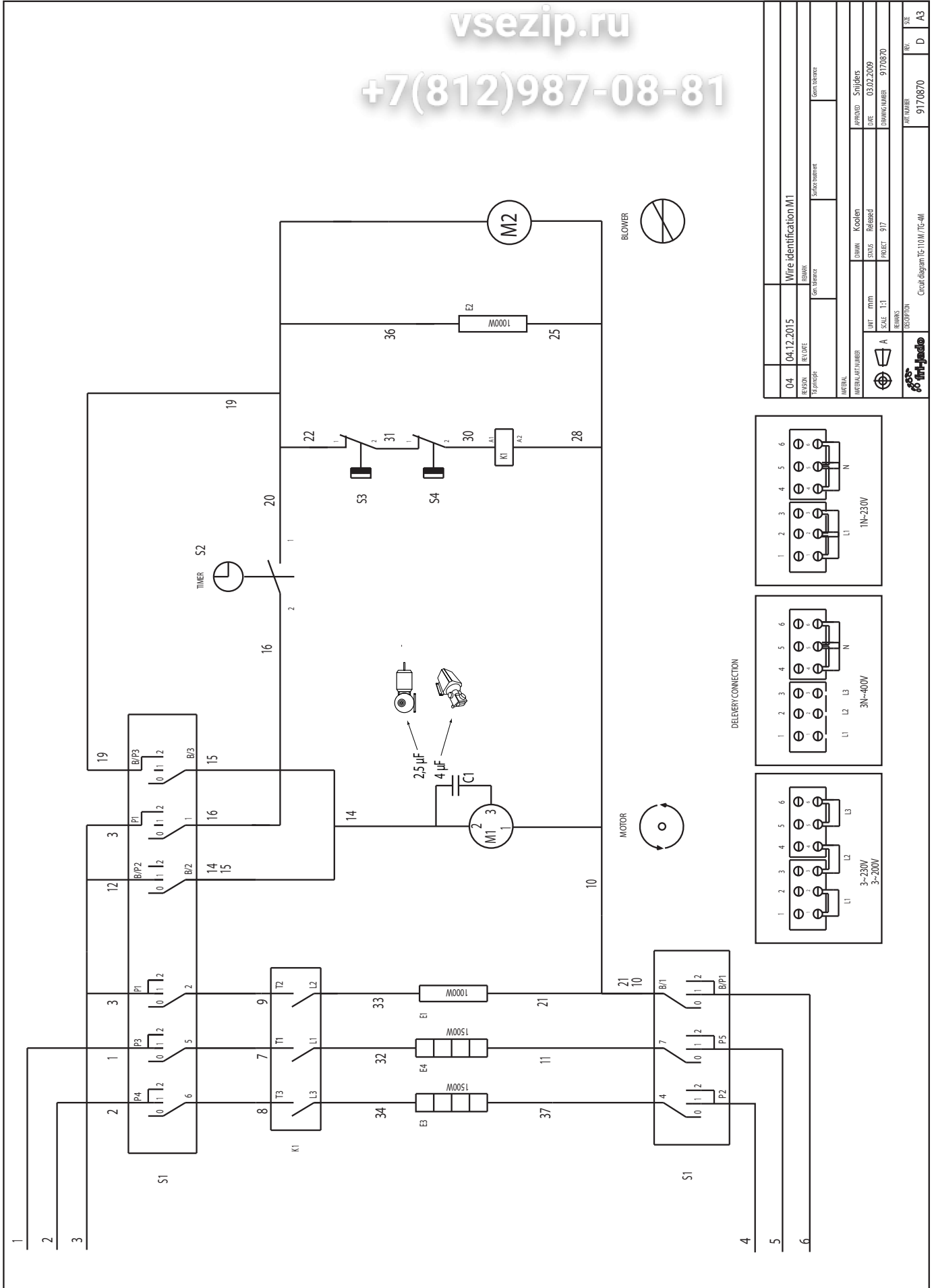

04		04.12.2015		Wire identification M1	
REASON	TELETYPE	REASON	REVISION	Blank	
Echoprojekt		Soprotovobnash		Soprotovobnash	
MATERIAL		MATERIAL/ARTICLE NUMBER		MATERIAL/ARTICLE NUMBER	
OK	OK	OK	OK	OK	OK
UNIT	mm	UNIT	mm	STATUS	Released
SCALE	1:1	SCALE	1:1	PACKET	917.0870
FORMS		FORMS		FORMS	
DESCRIPTION		DESCRIPTION		DESCRIPTION	
Circuit diagram TG-110M/TG-4M		Circuit diagram TG-110M/TG-4M		Circuit diagram TG-110M/TG-4M	
ART. NUMBER	917.0870	ART. NUMBER	917.0870	REV.	D
SIZE	D	SIZE	D	REV.	A3

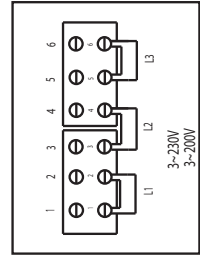
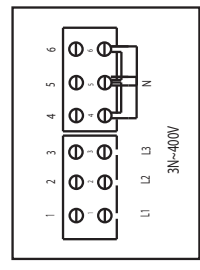
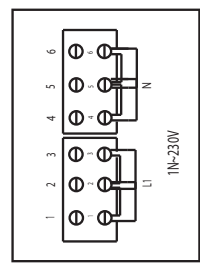

DELIVERY CONNECTION

WIRING DIAGRAM TG4 AND TG110 230V

Зип Общепит

vsezip.ru

+7(812)987-08-81

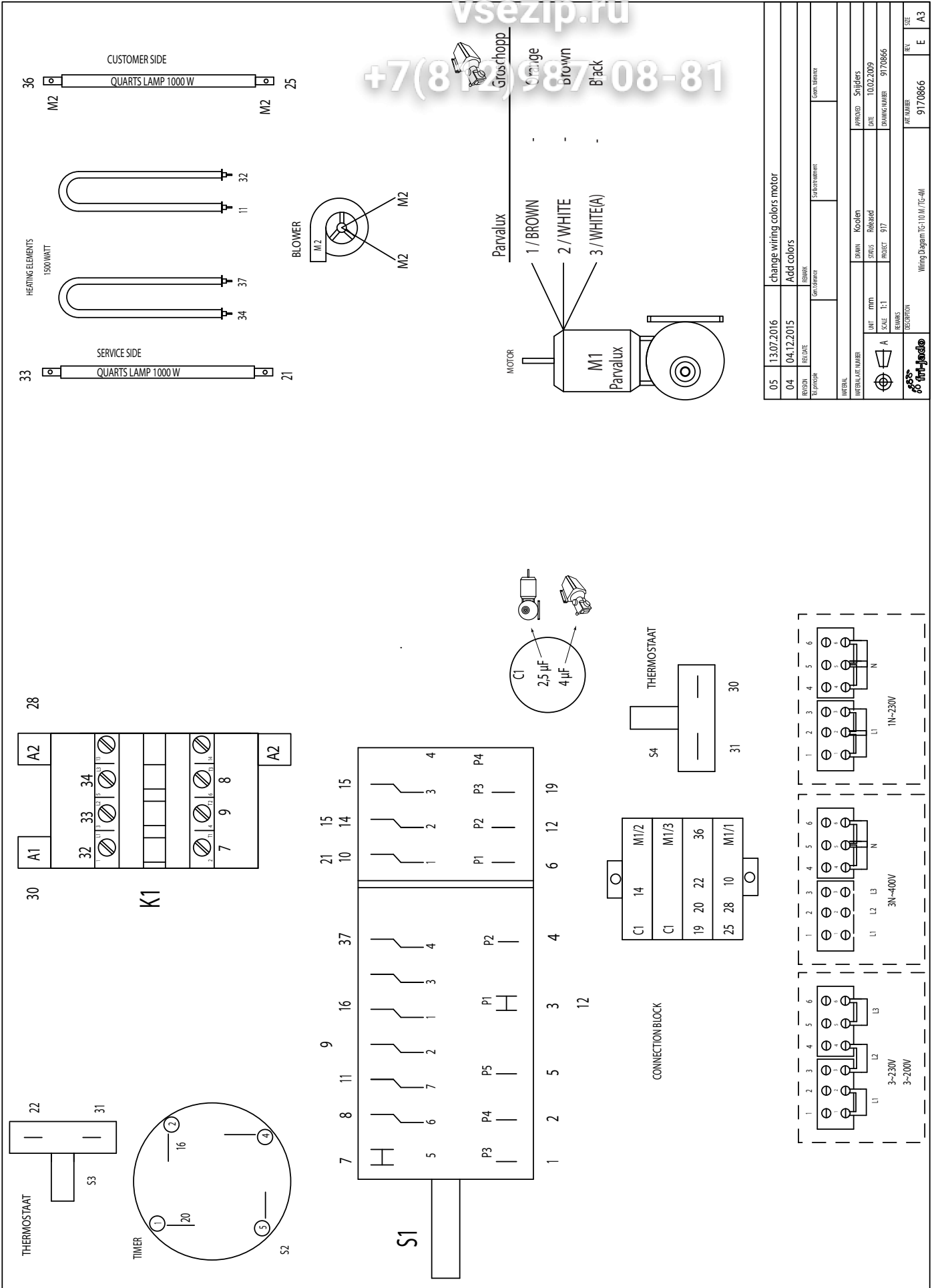

05	13.07.2016	change wiring colors motor
04	04.12.2015	Add colors
PERSON	DESIGNER	REVISION
TRAPROOF	GEN. ENGINEER	SPECIALIST
APPROVED	APPROVED	APPROVED
DATE	DATE	DATE
PROJECT	PROJECT	PROJECT
DRIVING NUMBER	DRIVING NUMBER	DRIVING NUMBER
9170866	9170866	9170866
REV.	REV.	REV.
E	A3	A3

Зип Общедит

vsezip.ru

+7(812)987-08-81

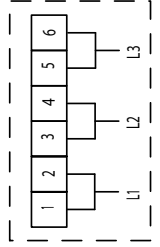
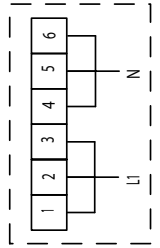
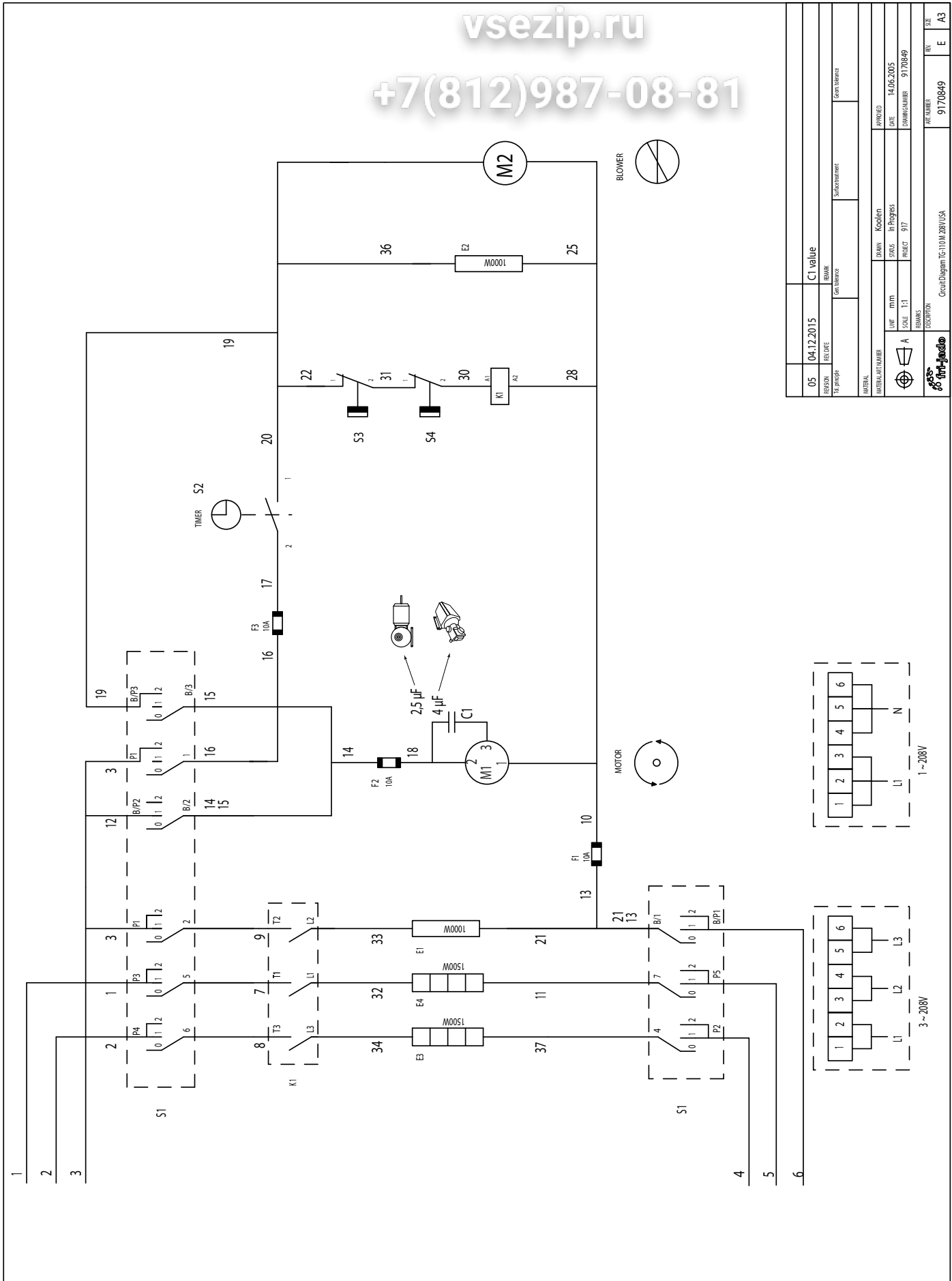

REVISION	05	DATE	04.12.2015	REMARK	C1 value
BY	SPINCH	DATE		BY	Gen. Manager
APPROVED		DATE		BY	Gen. Manager
DRAWN	Kozlen	DATE	14.06.2005	PROJECT	9170849
SCALE	In Progress	PROJECT	917		
UNIT	mm				
SCALE	1:1				
DRAWING NUMBER	9170849				
DESCRIPTION	Circuit Diagram TG-110M-208V/USA				
REVISION		DATE		BY	SIZE
					E A3

WIRING DIAGRAM TG4 AND TG110 208V

Зип Общепит

vsezip.ru

+7(812)987-08-81

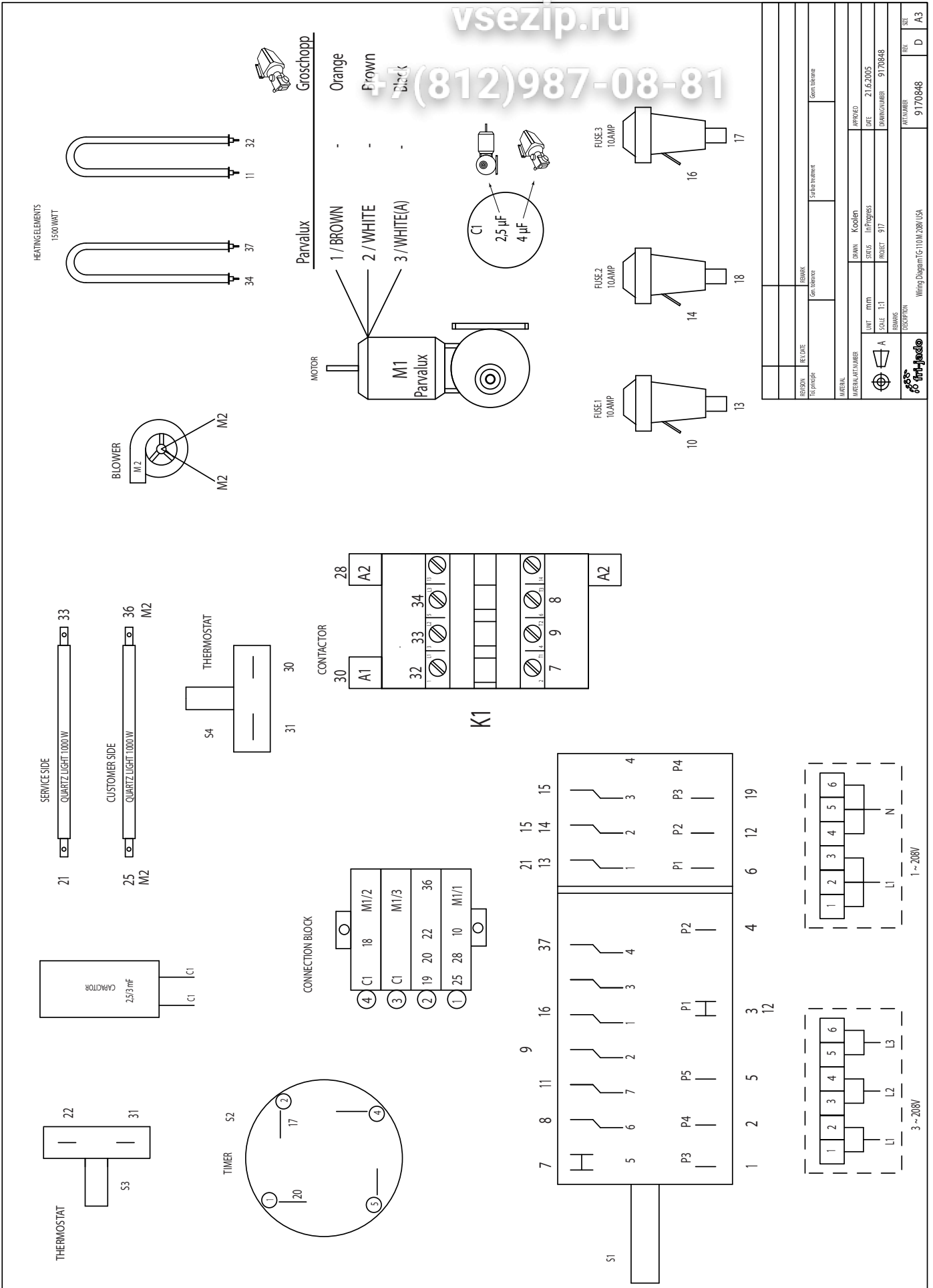

REVISION	REVISION	REVISION	REVISION
TELEPHONE	TELEPHONE	TELEPHONE	TELEPHONE
MATERIAL	MATERIAL	MATERIAL	MATERIAL
DATE	DATE	DATE	DATE
PROJECT	PROJECT	PROJECT	PROJECT
APPROVED	APPROVED	APPROVED	APPROVED
DRAWN	DRAWN	DRAWN	DRAWN
SCALE	SCALE	SCALE	SCALE
DESCRIPTION	DESCRIPTION	DESCRIPTION	DESCRIPTION
WIRING DIAGRAM	WIRING DIAGRAM	WIRING DIAGRAM	WIRING DIAGRAM
9170548	9170548	9170548	9170548
9170548	9170548	9170548	9170548
D	D	D	D
A3	A3	A3	A3

CIRCUIT DIAGRAM TG4 SB (SOLID BACK)

Зип Общедит

vsezip.ru

+7(812)987-08-81

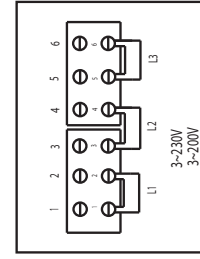
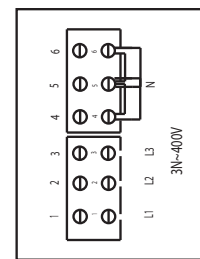
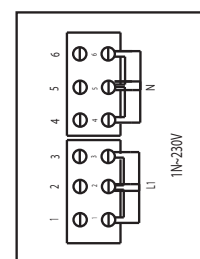
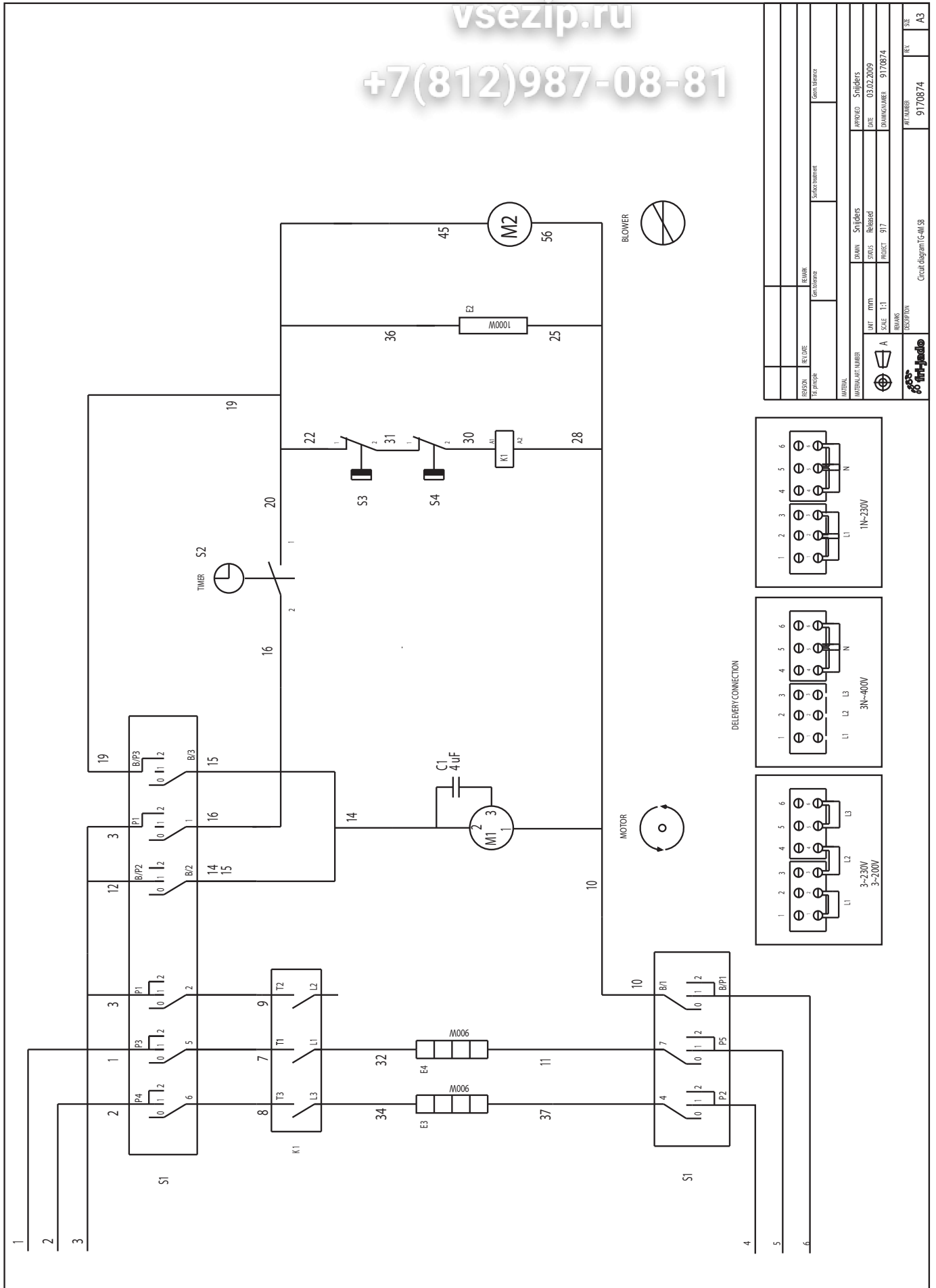

REGION	RU/DAK	REMARK	on tolerance	Surface treatment	on tolerance
ARTICLE NUMBER					
APPROVED	Snijders	DATE	03.02.2009	PROJECT	917/0874
STATUS	Released	SCALE	1:1		
DRAWN					
REVISION					
DESCRIPTION			Circuit diagram TG4 SB		
DATE	917/0874		REV	A3	

WIRING DIAGRAM TG4 SB (SOLID BACK)

Зип Общепит

vsezip.ru

+7(812)987-08-81

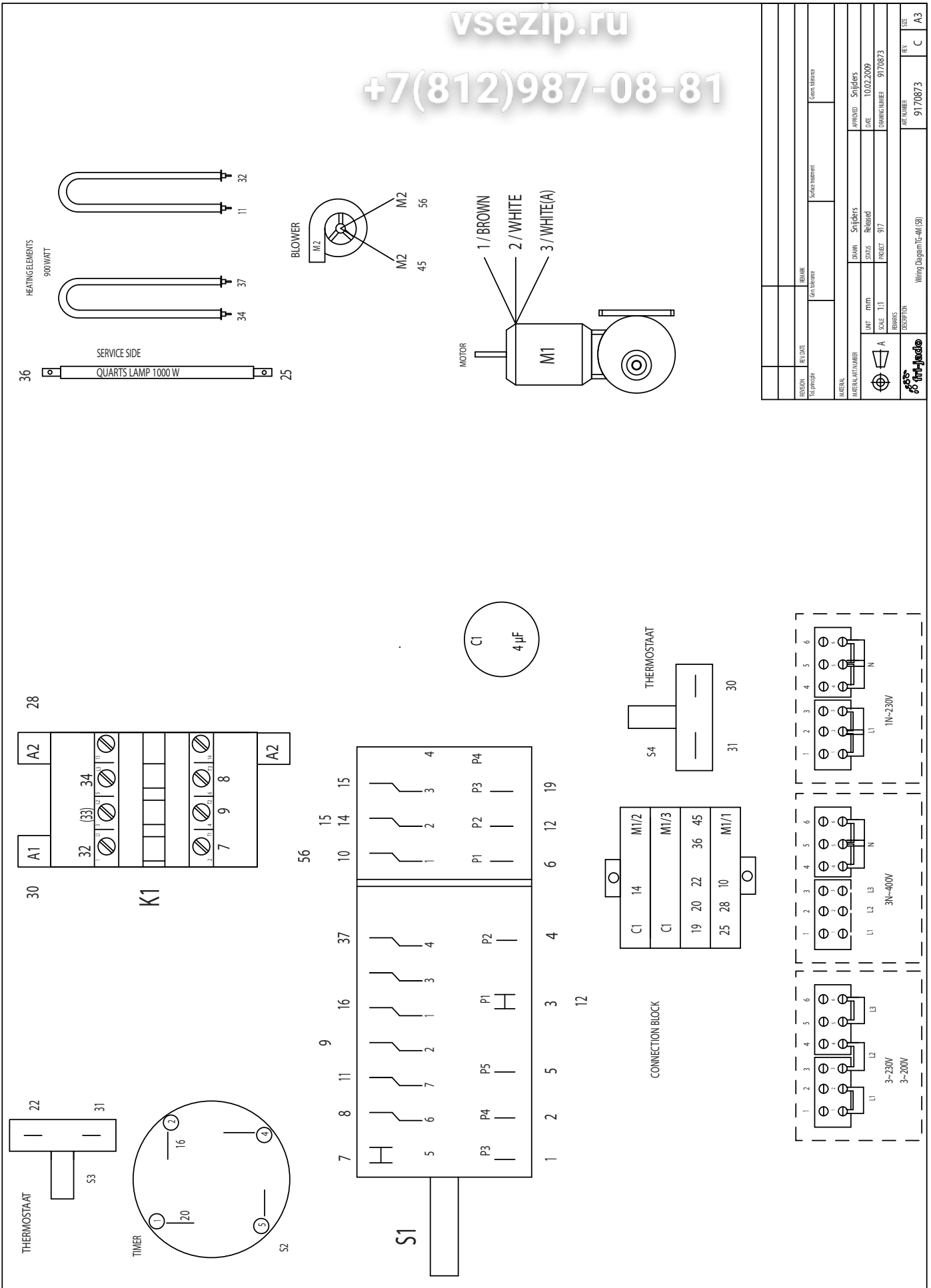

REVISION	REV. DATE	REMARK	DATE	SCALE	TITLE
DRAWN		CHECKED		DATE	
S. N. S. N.		S. N. S. N.		10.02.2009	
PROJECT		PROJECT		9170873	
DIMENSION		DIMENSION		9170873	
REVISION		REVISION		DATE	
REV. 1		REV. 1		10.02.2009	
DESCRIPTION		DESCRIPTION		Wiring Diagram (C-AM) (SB)	
REV. 1		REV. 1		DATE	
C		C		DATE	
A3		A3		DATE	

CIRCUIT DIAGRAM TG110 SB (SOLID BACK)

Зип Общепит

vsezip.ru

+7(812)987-08-81

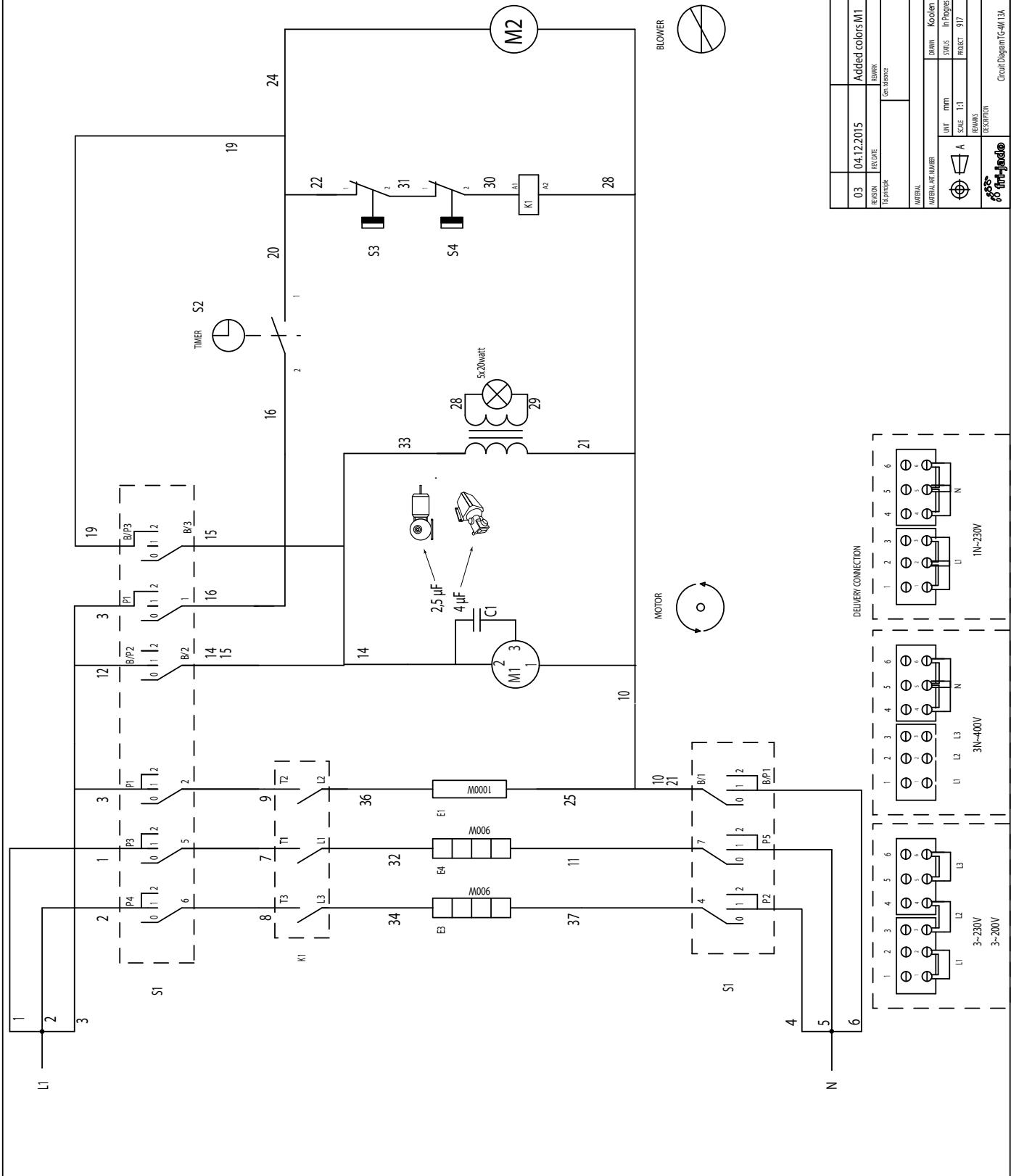

VERSION	04.12.2015	REVISION	Added colors M1
DATE	04.12.2015	DATE	10.02.2009
SCALE	1:1	PROJECT	9170951
PROJECT	917	DRAWING NUMBER	9170951
DESCRIPTION	Circuit Diagram TG-110 SB		
REV.	C	REV.	A3

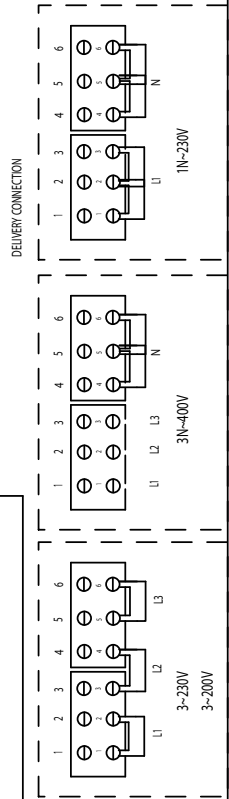

Зип Общепит
vsezip.ru
+7(812)987-08-81

