

Зип Общепит 
Wexiödisk
vsezip.ru

+7(812)987-08-81
**HOOD TYPE DISHWASHER
WD-7**

(translation of the original documentation)

Spare parts manual



WD67r1

1. Spare parts	1
1.1 External details	2
1.2 Hood lift	4
1.3 Tank details	6
1.4 Wash and rinse system	8
1.5 Water connections booster heater	10
1.6 Booster heater 400V 9kW	12
1.7 Booster heater (option)	14
1.8 Booster heater (option)	18
1.9 Electric cubicle	22
1.10 Booster pump (option)	24
1.11 Valve packet 301773	26
1.12 Valve packet 301783	28
1.13 Emptying pump (option)	30
1.14 Breaktank (option)	32
1.15 Backflow prevention device (option)	34
1.16 Support for bakery plates (option)	36
1.17 Rebuilding kit 460 basket (option)	38
1.18 Heat recovery by the exhausted steam (option)	40
1.19 Heat recovery by the drain water (option)	42
1.20 Pump 1225	44
1.21 Pump 2HM4T/A	46

vsezip.ru

+7(812)987-08-81

1. Spare parts



Switch off the machine immediately in the event of a fault or malfunction. The machine must only be serviced by trained engineers. The machine must be serviced by a person authorised to do so by the manufacturer. Use original spare parts. Contact an authorised service company to draw up a programme of preventative maintenance. Dangerous situations may arise if the instructions above are not followed.

When a position does not have item numbers, it has its own section in the spare parts manual.

Positions that have a * in front of the name is included in a complete article but can also be purchased separately.

1.1 External details

vsezip.ru

+7(812)987-08-81

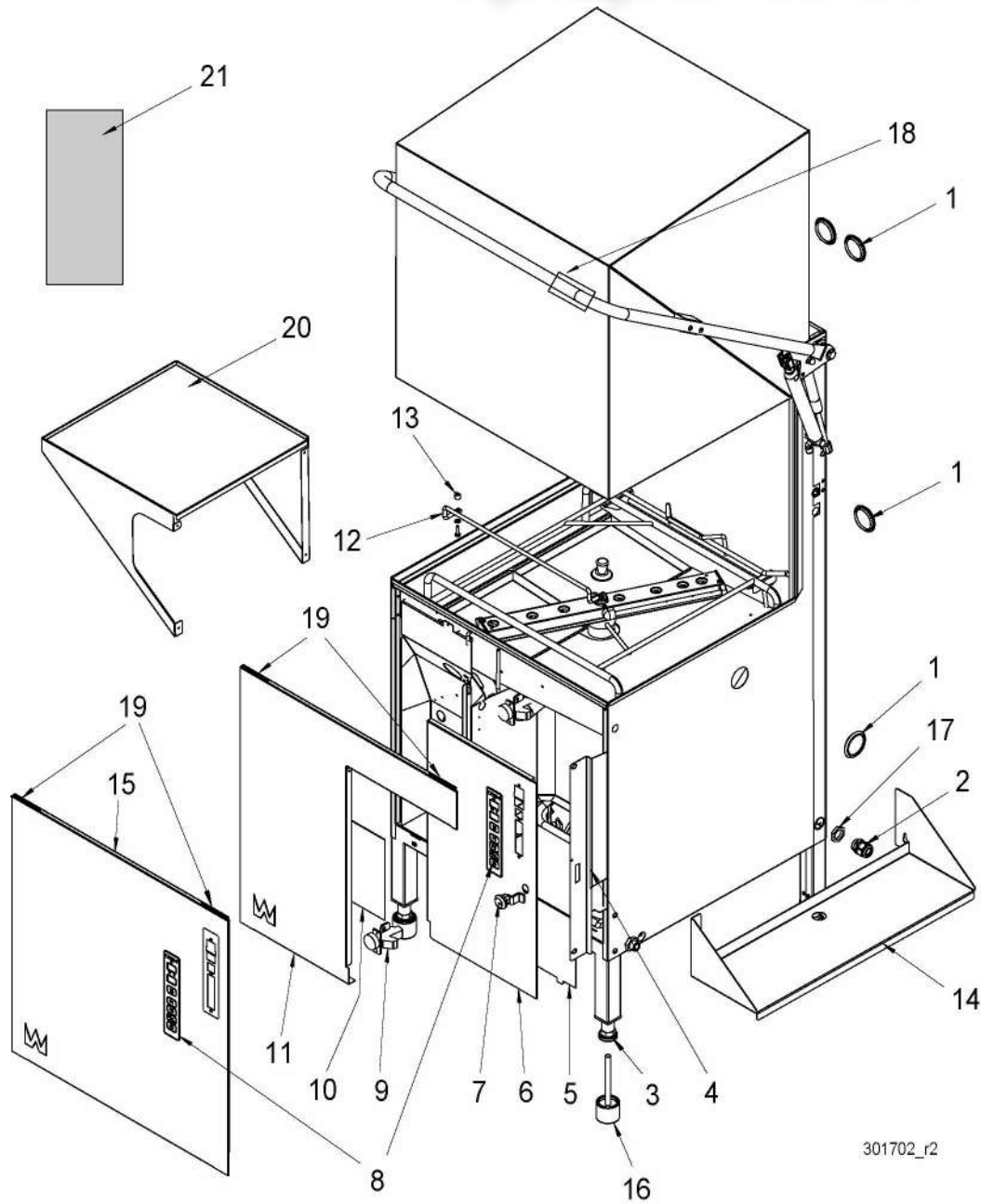

301702_r2

External details		
Pos	WD no	Description
1	WD718.1050	Plug
2	WD51476114	Cable screw cap 25 polyamid
3	WD718.0305	Foot grey 40x40 adjustable
3	WD42820.31	Foot blade (Option)
4	WD300684.31	Cabinet (Option)
5	WD300958.31	Base-cabinet (Option)
6	WD26923.31	Panel plate (Option)
7	WD792.0220	Cylinder lock (Option)
8	WD301060.03	Panel sign WD7
8	WD301736.01	Panel sign WD-7 Metos
8	WD301060.04	Panel sign WD-7 hoodautomaticity (Option)
8	WD301736.02	Panel sign WD-7 Metos hoodautomaticity (Option)
9	WD790.0301	Hinge door (Option)
10	WD724.0502	Plastic case A4
11	WD26991.31	Front plate (Option)
12	WD44880.31	Side support O494
13	WD44930.31	Distance basket frame rail
14	WD27316.31	Shelf left side (Option)
14	WD27316.32	Shelf right side (Option)
15	WD26920.01	Front plate right with bumping
15	WD26920.02	Front plate left without bumping (Option)
15	WD26920.03	Front plate right without bumping
16	WD46202.01	Extension leg (Option)
17	WD51476534	Locking nut 25 polyamid
18	WD45941.31	Model sign WD
18	WD42868.31	Model sign Metos
18	WD42998.31	Model sign Rhima
18	WD46094.31	Model sign Ravimo / Shark
19	WD719.0512	Sealing strip 8x2mm
20	WD27362.31	Sideboard
21	WD724.6006	Quick reference WD-6/WD-7 without hood lift
21	WD724.6005	Quick reference WD-6/WD-7 with hood lift (Option)
21	WD724.6024	Quick guide to WD-6/WD-7 without hood lift and with drain pump (optional)
21	WD724.6025	Quick guide to WD-6/WD-7 with hood lift and with drain pump (optional)

1.2 Hood lift

vsezip.ru

+7(812)987-08-81

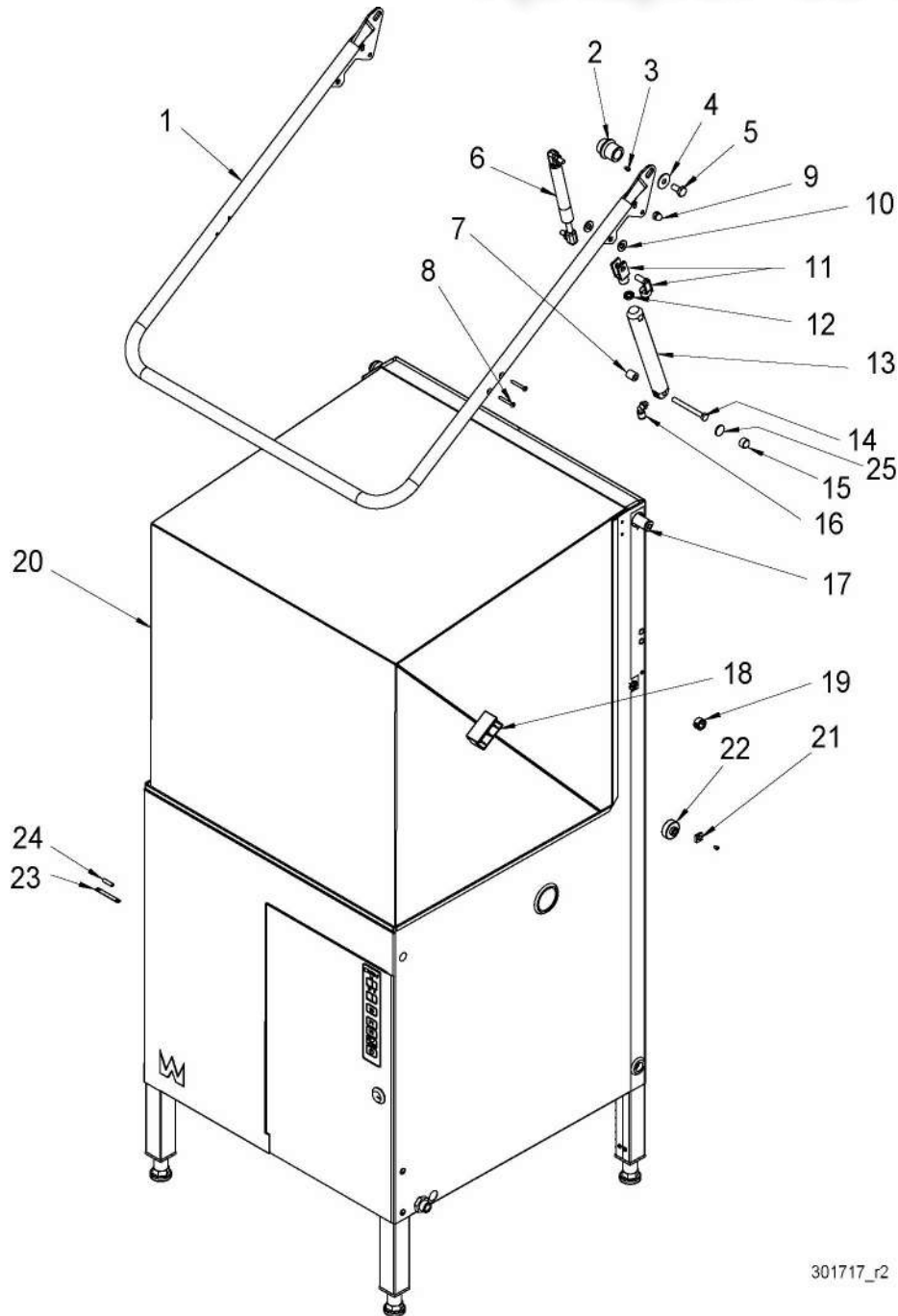

301717_r2

Hood lift		
Pos	WD no	Description
1	WD38833.01	Lifting handle op
2	WD45256.31	Bearing liftlamp
3	WD700.0207	Screw MC6S M4x6 A2
4	WD45310.31	Washer
5	WD700.0148	Screw M6S M10x20
6	WD713.0512	Gas spring800N ball joint
6	WD713.0506	Gas spring 500N protection cap (option)
7	WD701.0110	Distance cylinder hold (Option)
8	WD700.0824	Screw KFSS 4.8x38 A2
9	WD700.1105	Nut RMHM M8 A2
10	WD701.0115	Plastic washer 10.5x21x3.0mm (Option)
11	WD737.0150	Fork link (Option)
12	WD737.0153	Nut M6M M10x1.25 fzb (Option)
13	WD737.0180	Cylinder (Option)
14	WD46217.31	Pin bolt for hood lift (Option)
15	WD718.1108	Nut cover (Option)
16	WD706.0915	L-coupling (Option)
17	WD38828.31	Axle hood lift
18	WD41223.31	Hood bearing WD6/7
19	WD61701519	Conduit entry
20	WD25941.01	Hood
21	WD40016.31	* Sliding block
22	WD41224.31	* Sliding roller
23	WD46521.31	* Magnet holder
24	WD602.0551	* Magnet
25	WD700.0906	Nut ML6M M10 A2

1.3 Tank details

vsezip.ru

+7(812)987-08-81

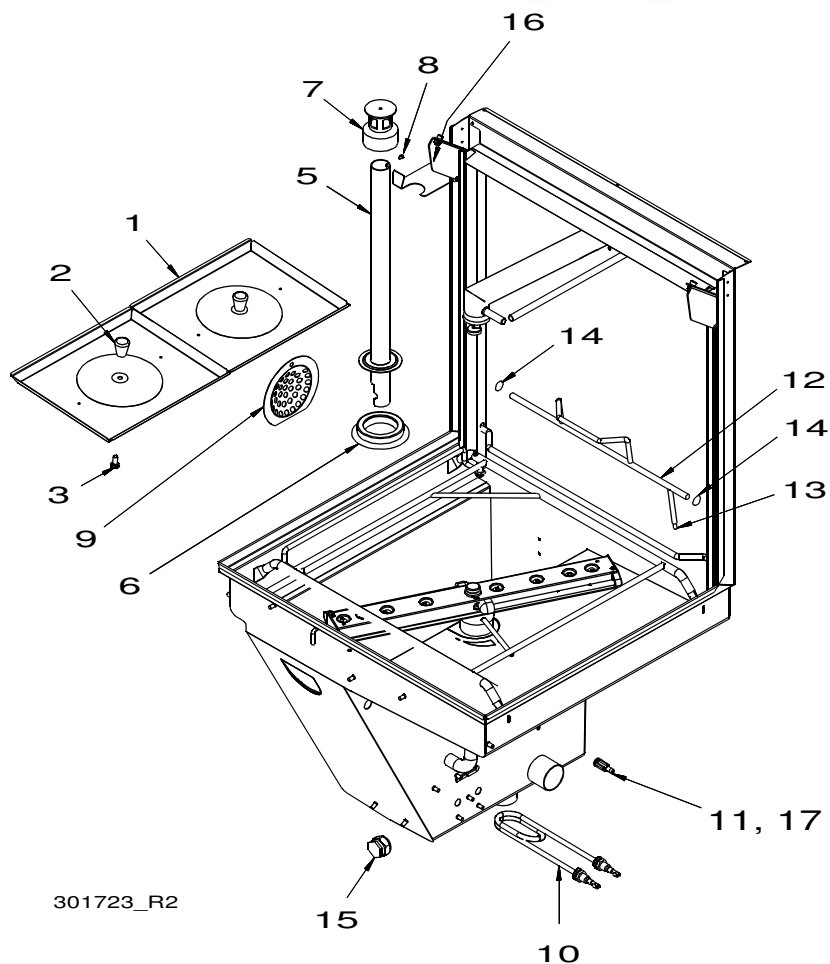

Tank details		
Pos	WD no	Description
1	WD301689.01	Chem strainer
2	WD718.0826	* Nob
3	WD700.2864	* Screw M6SF M8x25 A2
4	WD38210.01	Level pipe
5	WD44643.01	* Level pipe
6	WD719.4036	* Level pipe sealing
7	WD41225.31	* Foam remover
8	WD700.0607	* Screw MCS M4x6 A2
9	WD32422.31	Pumpstrainer chemical
10	WD604.1805	Element 1800W 230V
11	WD45152.31	Dosage connection, floating
12	WD304150.75	Breaker with axle (Option)
13	WD602.0551	* Magnet round 6x50 (Option)
14	WD701.2010	Stop collar ø10mm
15	WD705.1022	Coupling test pressure
	WD705.0323	* Clamping sleeve 22mm
	WD705.0207	* Nut Lk 63 22
16	WD46198.31	Level pipe support (Option)
17	WD43861.31	O-ring

1.4 Wash and rinse system

vsezip.ru

+7(812)987-08-81

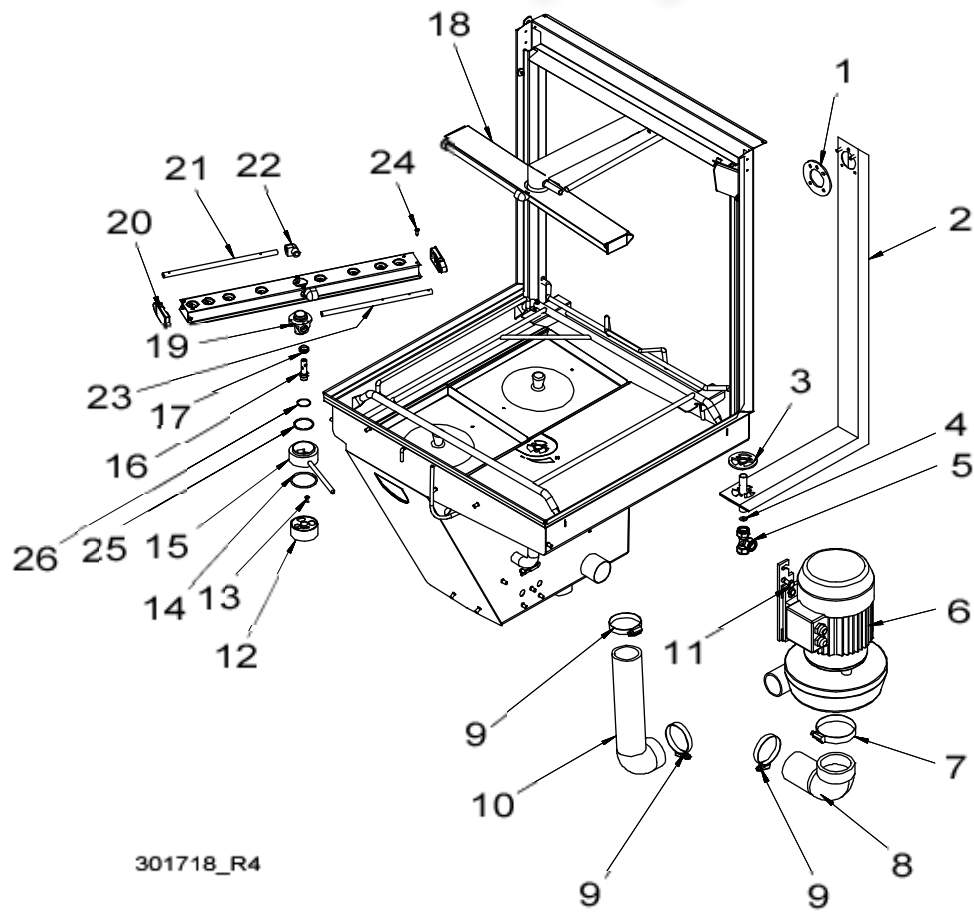

301718_R4

Wash and rinse system		
Pos	WD no	Description
1	WD44625.31	Rubber stopping upper rinse pipe
2	WD39459.01	Main pipe
3	WD44626.31	Rubber stopping lower rinse pipe
4	WD46188.31	Adjusting plate
5	WD705.2706	T-Coupling
6	WD301169.01	Pump with attachment , cpl
7	WD714.0112	Hose clamp 60-80 mm
8	WD36364.31	Pump connection inlet
9	WD714.0111	Hose clamp 50-70 mm
10	WD38232.31	Pump connection
11	WD700.0132	Screw M6S M8x16 A2
12	WD45232.01	Connectioncase throttle
13	WD700.0609	Screw MCS M4x10 A2
14	WD719.1092	O-ring
15	WD45277.01	Throttle
16	WD44600.31	Neck
17	WD719.0111	V-ring V16S
18	WD27252.01	Rinse arm
19	WD46852.01	* Rinse arm bearing, complete
20	WD38719.31	* End cover
21	WD45136.01	* Rinse pipe
22	WD44969.31	* Rinse pipe attachment
23	WD45136.02	* Rinse pipe
24	WD700.2001	* Screw RXS Z T4.2x9.5 A4
25	WD45233.31	Stop washer throttle
26	WD45309.31	Spacer for damper

1.5 Water connections booster heater

+7(812)987-08-81

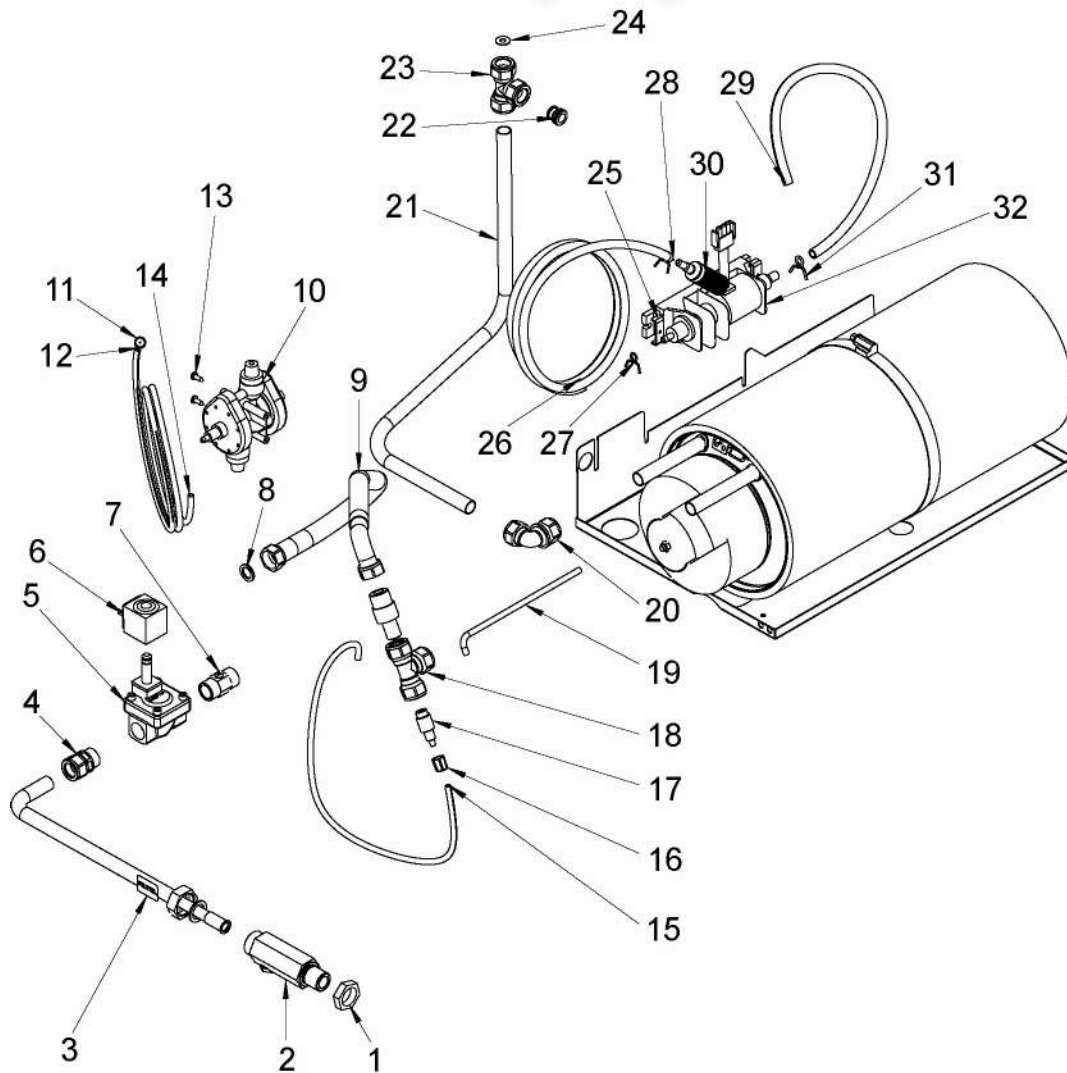

301722_R3

Water connections booster heater vsezip.ru		
Pos	WD no	Description
1	WD706.0203	Nut R 1/2"
2	WD39325.01	Incoming water connection
	WD40301.01	* Strainer w supporting housing
	WD701.0123	* Packing 24x17x2
2	WD741.7019	Incoming water connection (Option)
	WD706.1303	* Cap (Option)
	WD706.0809	* Nipple (Option)
	WD701.0123	* Packing (Option)
3	WD45234.31	Marksign "FILTER"
4	WD705.0915	Coupling 302-15xr15
	WD705.0405	* Clamping sleeve
	WD705.0205	* Nut LK 63-15
5	WD729.1540	Solenoid valve, housing
6	WD729.1519	Coil 24V/50 10W
7	WD709.0809	Ball valve
8	WD701.0122	Packing 1/2"
9	WD719.5024	Slang RFR F1/2"xFC1/2" L=510
10	WD716.0401	Drying agent pump N6
11	WD716.0404	Strainer
12	WD42946.31	Reinforcement pin
13	WD700.2001	Screw RXS Z T4.2x9.5 A4
14	WD716.0402	Hose 4x6 L=2m
15	WD716.0405	Pressure hose 4x6 L=0,6m
16	WD716.0403	Attachment nut N6
17	WD45985.31	Connection nipple
18	WD705.2205	Coupling 15mm, brass
19	WD45994.31	Tube drying agent connection
20	WD705.1607	Coupling, angeled 1/2" x 15
	WD705.0420	* Clamping sleeve 15mm
	WD705.0316	* Nut 15mm
21	WD301069.31	Tube booster heater final rinse
22	WD705.0421	Clamping sleeve 15-10
23	WD705.2215	T-Coupling15mm
	WD705.0420	* Clamping sleeve 15mm
	WD705.0316	* Nut 15mm
24	WD46188.31	Adjusting plate
25	WD41115.32	Clamp detergent pump
26	WD719.0305	Hose PVC 6x9 L=2m
27	WD714.0408	Hose clamp Remin RSF 8-1
28	WD42887.31	Reinforcement pin
29	WD719.0307	Hose PVC 7-10 L=0,5m
30	WD716.0504	Detergent pump strainer
31	WD714.0411	Hose clamp Remin RSF 11-1
32	WD716.0501	Detergent pump GRI 14825
	WD716.0506	* Hose nipple pressure
	WD716.05061	* Hose nipple soak

1.6 Booster heater 400V 9kW vsezip.ru

+7(812)987-08-81

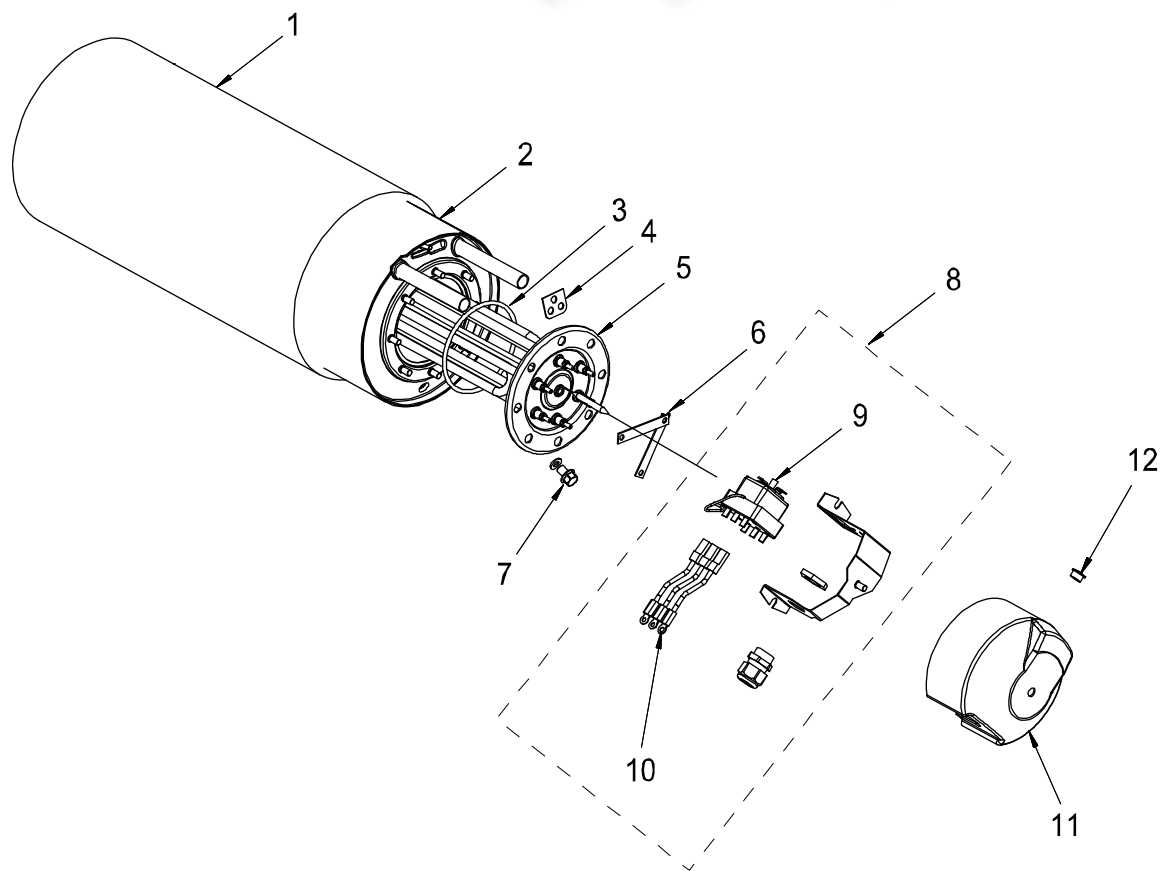

WD01163.36

Booster heater 400V 9kW		
Pos	WD no	Description
	WD01163.36	Booster heater 400V 9kW
1	WD809.0903	* Heat insulation booster heater
2	WD01162.04	* Container booster heater (E)
3	WD719.1090	* O-ring
4	WD44203.31	* Attachment temp.sensor
5	WD30835.01	* Element 9 kW, 230/400 V
6	WD04920.31	* Copper clamp
7	WD700.2501	* Collar screw + Gasket
8	WD302113.01	* Overheating protection tankelement 400V
9	WD734.0110	** Overheating protection
10	WD670.8244	** Coupling conductor
11	WD301321.31	Protection cover
12	WD51476571	End plug

1.7 Booster heater (option)

vsezip.ru

+7(812)987-08-81

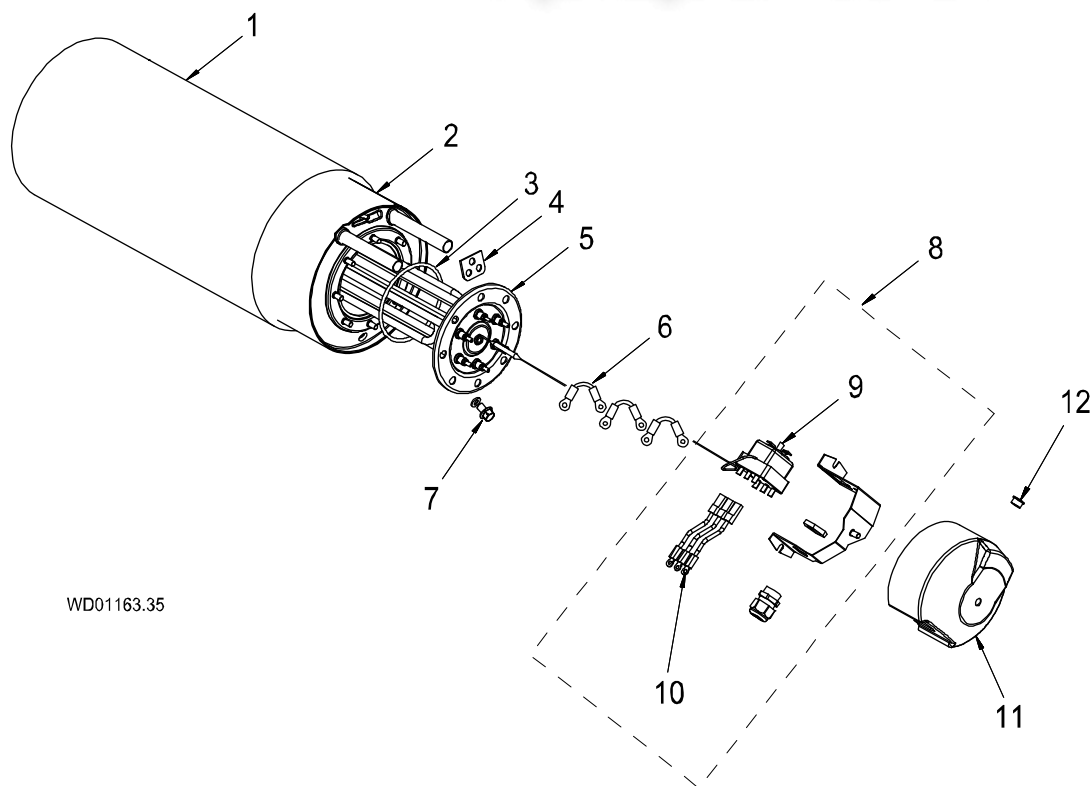

WD01163.35

Booster heater (option)		
Pos	WD no	Description
	WD01163.35	Booster heater 200V, 9 kW
1	WD809.0903	* Heat insulation booster heater
2	WD01162.04	* Container booster heater (E)
3	WD719.1090	* O-ring
4	WD44203.31	* Attachment temp.sensor
5	WD30835.01	* Element 9 kW, 230/400V
6	WD67182105	* Cable bridge
7	WD700.2501	* Collar screw + Gasket
8	WD302113.01	* Overheating protection tankelement 400V
9	WD734.0110	** Overheating protection
10	WD670.8244	** Coupling conductor
11	WD301321.31	Protection cover
12	WD51476571	End plug
	WD01163.37	Booster heater 200V 9kW
1	WD809.0903	* Heat insulation booster heater
2	WD01162.04	* Container booster heater (E)
3	WD719.1090	* O-ring
4	WD44203.31	* Attachment temp.sensor
5	WD30835.15	* Element 9 kW, 200 V
6	WD67182105	* Cable bridge
7	WD700.2501	* Collar screw + Gasket
8	WD302113.02	* Overheating protection tankelement 230V
9	WD734.0110	** Overheating protection
10	WD670.8244	** Coupling conductor
11	WD301321.31	Protection cover
12	WD51476571	End plug

vsezip.ru

+7(812)987-08-81

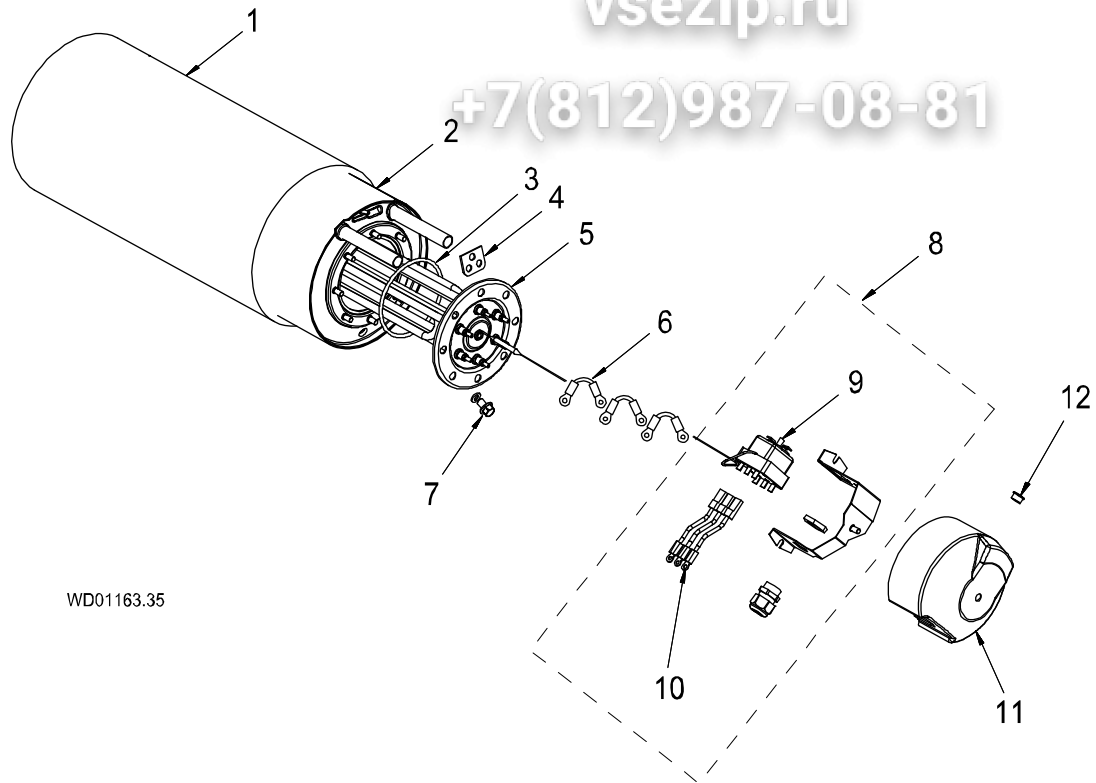

WD01163.35

Booster heater (option)		
Pos	WD no	Description
	WD01163.41	Booster heater 200V 12kW
1	WD809.0903	* Heat insulation booster heater
2	WD01162.04	* Container booster heater (E)
3	WD719.1090	* O-ring
4	WD44203.31	* Attachment temp.sensor
5	WD30835.13	* Element 12 kW, 200 V
6	WD67182105	* Cable bridge
7	WD700.2501	* Collar screw + Gasket
8	WD302113.02	* Overheating protection tankelement 230V
9	WD734.0110	** Overheating protection
10	WD670.8244	** Coupling conductor
11	WD301321.31	Protection cover
12	WD51476571	End plug
	WD01163.47	Booster heater 230V 12kW
1	WD809.0903	* Heat insulation booster heater
2	WD01162.04	* Container booster heater (E)
3	WD719.1090	* O-ring
4	WD44203.31	* Attachment temp.sensor
5	WD30835.02	* Element 12kW, 230/400V
6	WD67182105	* Cable bridge
7	WD700.2501	* Collar screw + Gasket
8	WD302113.01	* Overheating protection tankelement 400V
9	WD734.0110	** Overheating protection
10	WD670.8244	** Coupling conductor
11	WD301321.31	Protection cover
12	WD51476571	End plug

1.8 Booster heater (option)

vsezip.ru

+7(812)987-08-81

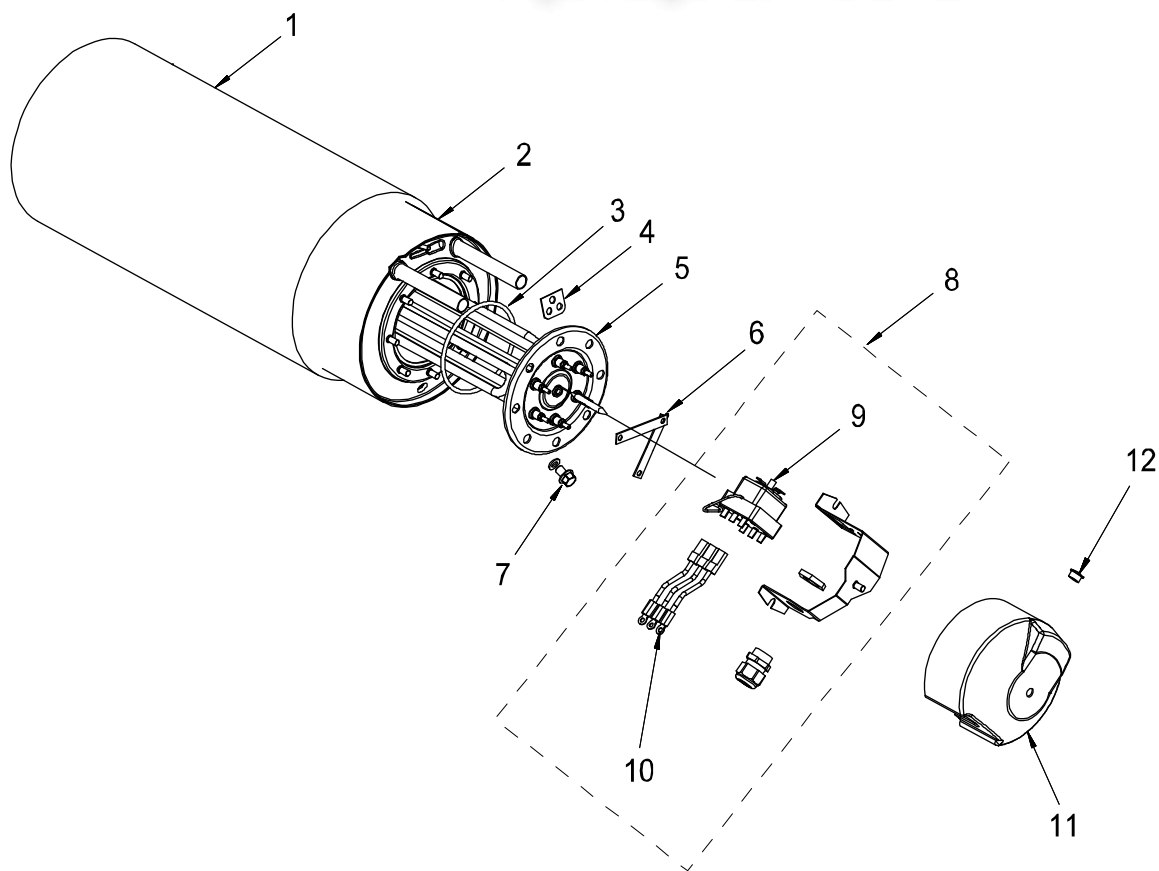

WD01163.39

Booster heater (option)		
Pos	WD no	Description
	WD01163.39	Booster heater 40V 9kW
1	WD809.0903	* Heat insulation booster heater
2	WD01162.04	* Container booster heater (E)
3	WD719.1090	* O-ring
4	WD44203.31	* Attachment temp.sensor
5	WD30835.18	* Element 9kW, 254/440V
6	WD04920.31	* Copper clamp
7	WD700.2501	* Collar screw + Gasket
8	WD302113.01	* Overheating protection tankelement 400V
9	WD734.0110	** Overheating protection
10	WD670.8244	** Coupling conductor
11	WD301321.31	Protection cover
12	WD51476571	End plug
	WD01163.40	Booster heater 400V 12kW
1	WD809.0903	* Heat insulation booster heater
2	WD01162.04	* Container booster heater (E)
3	WD719.1090	* O-ring
4	WD44203.31	* Attachment temp.sensor
5	WD30835.02	* Element 12 kW, 230/400 V
6	WD04920.31	* Copper clamp
7	WD700.2501	* Collar screw + Gasket
8	WD302113.01	* Overheating protection tankelement 400V
9	WD734.0110	** Overheating protection
10	WD670.8244	** Coupling conductor
11	WD301321.31	Protection cover
12	WD51476571	End plug

vsezip.ru

+7(812)987-08-81

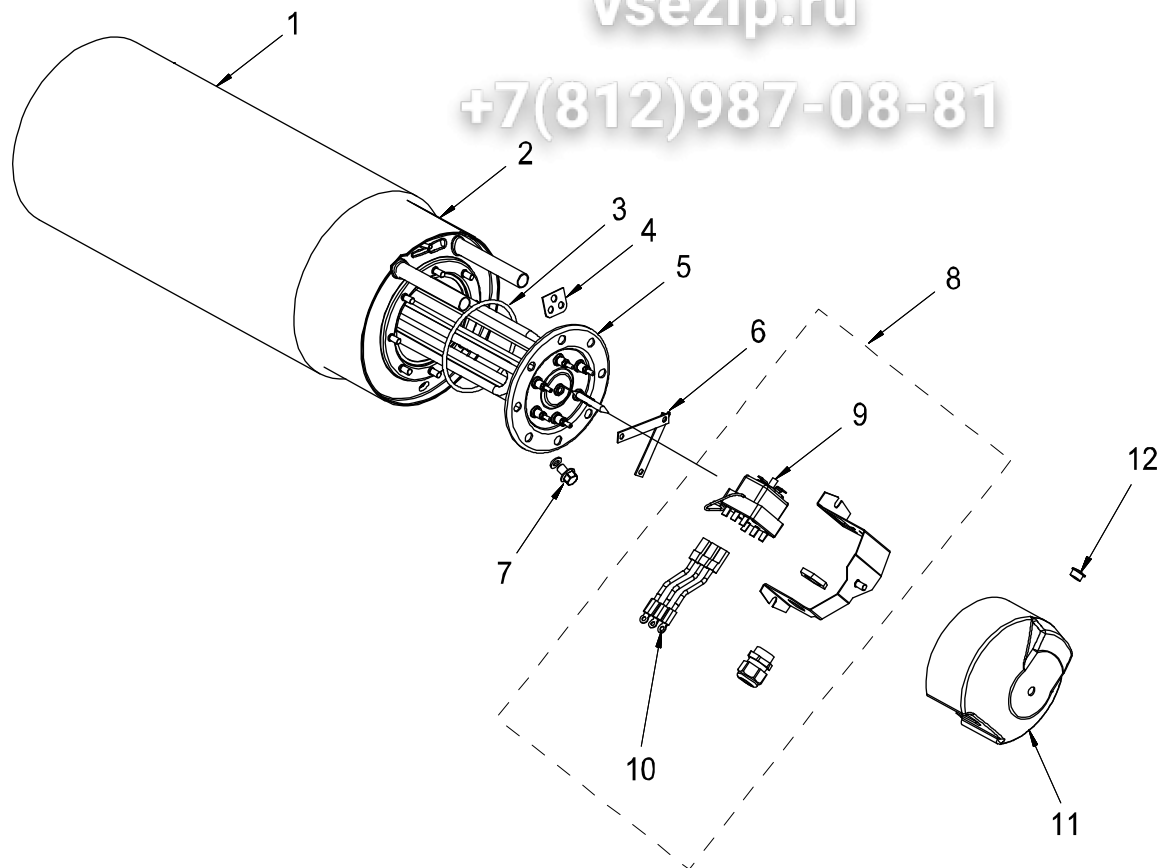

WD01163.39

Booster heater (option)		
Pos	WD no	Description
	WD01163.42	Booster heater 40V 12kW
1	WD809.0903	* Heat insulation booster heater
2	WD01162.04	* Container booster heater (E)
3	WD719.1090	* O-ring
4	WD44203.31	* Attachment temp.sensor
5	WD30835.12	* Element 12 kW, 440 V
6	WD04920.31	* Copper clamp
7	WD700.2501	* Collar screw + Gasket
8	WD302113.01	* Overheating protection tankelement 400V
9	WD734.0110	** Overheating protection
10	WD670.8244	** Coupling conductor
11	WD301321.31	Protection cover
12	WD51476571	End plug
	WD01163.48	Booster heater 400V 15kW
1	WD809.0903	* Heat insulation booster heater
2	WD01162.04	* Container booster heater (E)
3	WD719.1090	* O-ring
4	WD44203.31	* Attachment temp.sensor
5	WD30835.20	* Element 15kW, 230/400V
6	WD04920.31	* Copper clamp
7	WD700.2501	* Collar screw + Gasket
8	WD302113.01	* Overheating protection tankelement 400V
9	WD734.0110	** Overheating protection
10	WD670.8244	** Coupling conductor
11	WD301321.31	Protection cover
12	WD51476571	End plug

1.9 Electric cubicle

vsezip.ru

+7(812)987-08-81

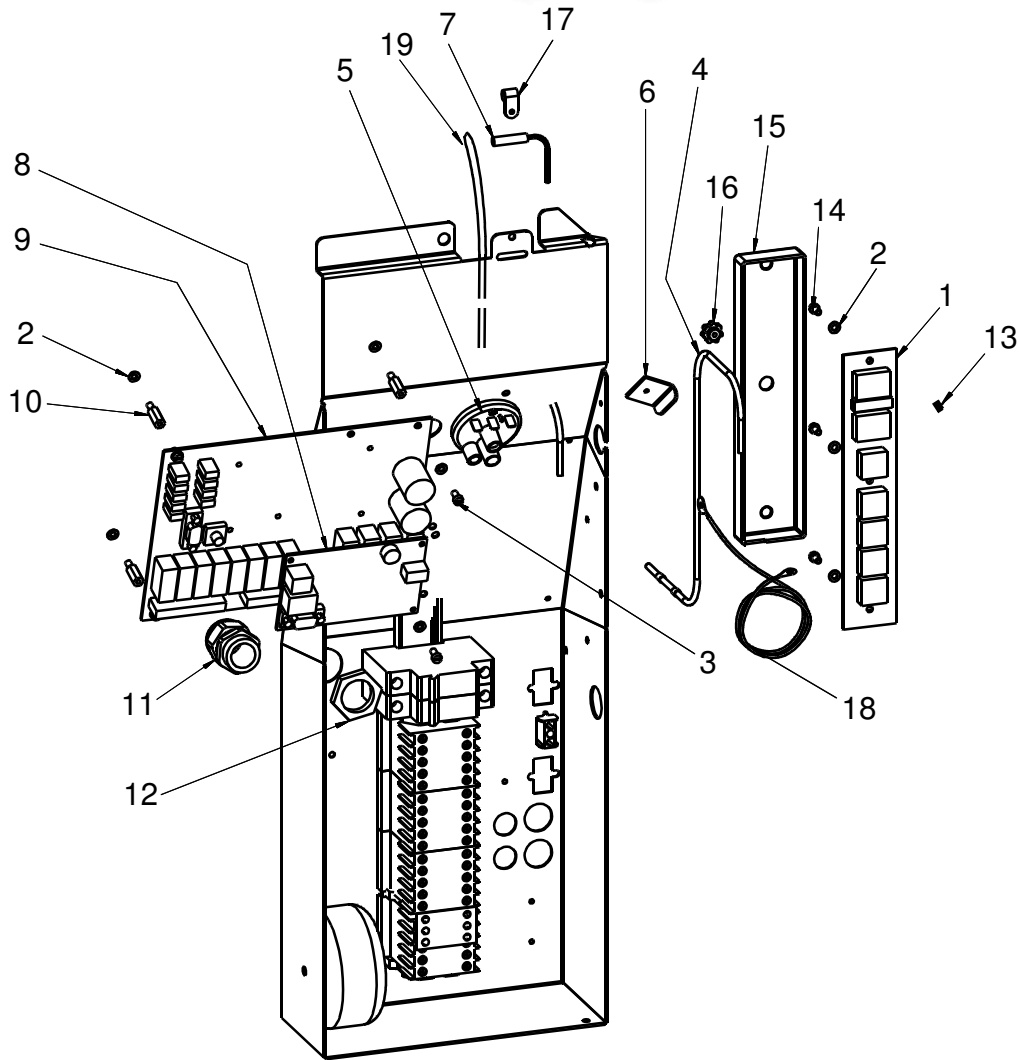

301769_R2

Electric cubicle		
Pos	WD no	Description
1	WD61102100	Panelcard ESP
2	WD702.1205	Lock washer IZ 4.3 steel izo
3	WD700.0608	Screw MCS M4x8 A2
4	WD61111300	Temp.sensor
5	WD733.0103	Pressure switch, gold
6	WD04196.31	Pressure switch attachment
7	WD60231734	Fieldbreaker switch
7	WD67182953	Fieldbreaker switch (Option)
8	WD61103000	CPU card ESP
9	WD61101100	Computercard ESP
10	WD702.2015	Distance nut
11	WD51476114	Cable screw cap 25 polyamid
12	WD51476534	Locking nut 25 polyamid
13	WD702.2207	Distance tube
14	WD700.1603	Locking nut M4 A2
15	WD301794.31	Defence to panelcard
16	WD718.0724	Plastic nut M4 white RG114
17	WD51402612	Plastic holder
18	WD67182111	Cable to front plate
19	WD719.0310	Hose EPDM 7x4mm L=0,8m

1.10 Booster pump (option)

vsezip.ru

+7(812)987-08-81

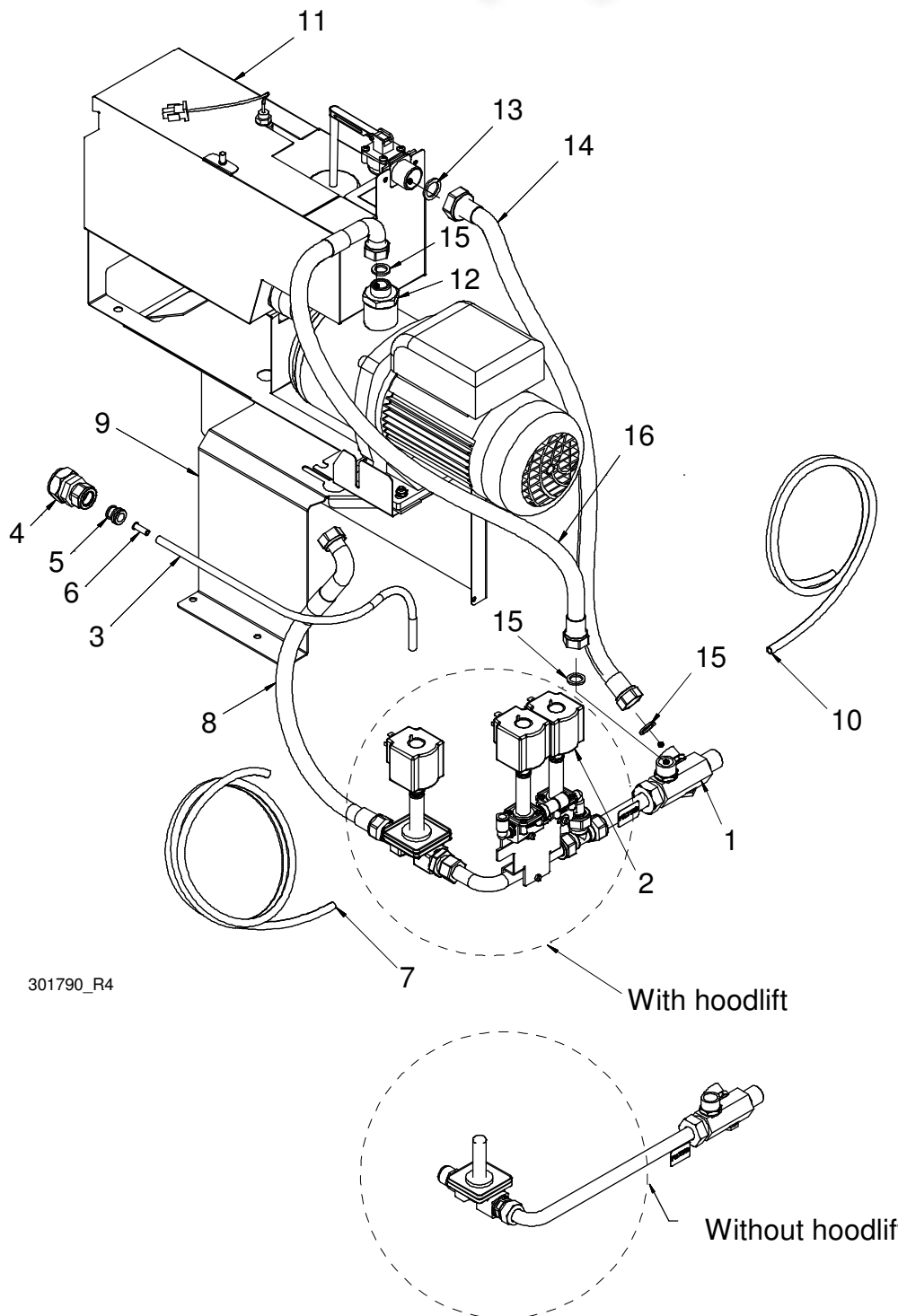

Booster pump (option)		
Pos	WD no	Description
1	WD301783.01	Coil 24V/50Hz 10W
2	WD729.1519	Nylon tube L=0,5m
3	WD737.0408	Coupling
4	WD705.0922	* Clamping sleeve 22mm
	WD705.0323	* Nut 22 mm
	WD705.0322	* Clamping sleeve 15mm
	WD705.0420	* Nut 15mm
	WD705.0315	Clamping sleeve 15-10
5	WD705.0421	Supporting sleeve fpl 720 8x1.0
6	WD705.0101	Nylon tube L=1,6m
7	WD737.0408	Slang RFR F1/2"xFC1/2"
8	WD719.5024	Attachment booster pump
9	WD300187.31	Nylon tube L=1,3m
10	WD737.0408	Breaktank, kpl
11		Hexagon nipple
12	WD706.0813	* Packing 24x17x2
13	WD701.0123	Steel braided hose
14	WD47153.01	Packing 1/2"
15	WD701.0122	Steel braided hose
16	WD47139.01	Coil 24V/50Hz 10W

1.11 Valve packet 301773

vsezip.ru

+7(812)987-08-81

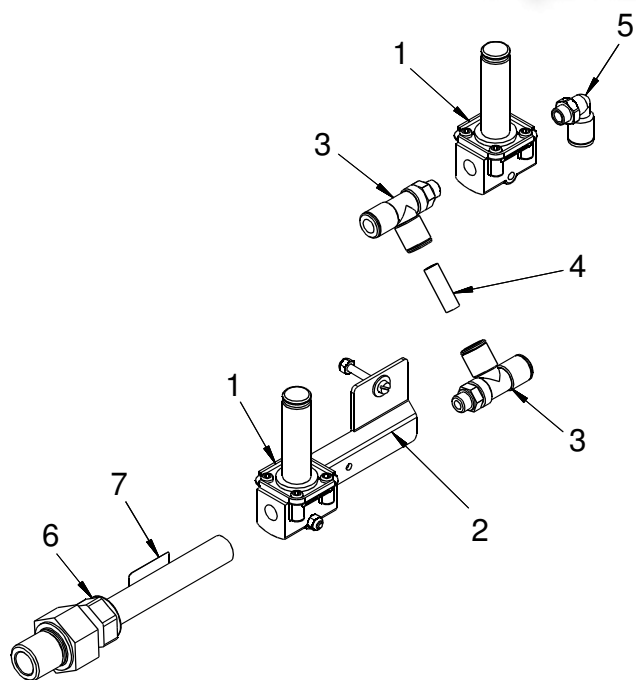

303071_R2

Valve packet 301773		
Pos	WD no	Description
	WD301773.02	Valve packet hood lift
1	WD729.2840	* Solenoid valve housing
2	WD46736.31	* Anchor plate
3	WD706.0927	* T-connection 8-1/8"
4	WD737.0408	* Hose D8 L=30
5	WD706.0915	* L-coupling
6	WD301774.02	Incoming water connection
	WD701.0122	* Packing 1/2"
	WD40301.01	* Strainer w supporting housing
7	WD45234.31	Marksign "FILTER"

1.12 Valve packet 301783

vsezip.ru

+7(812)987-08-81

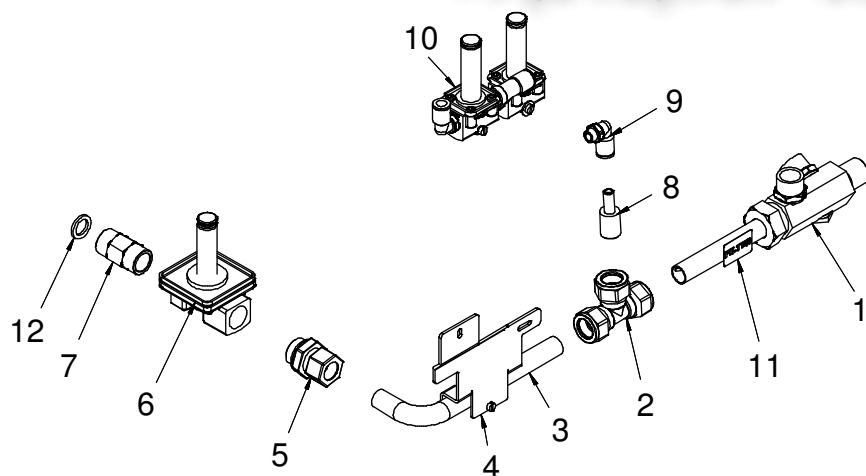

303056_R2

Valve packet 301783		
Pos	WD no	Description
	WD301783.01	Valve packet hood lift
1	WD301779.01	* Incoming water connection
	WD701.0123	** Packing 24x17x2
	WD40301.01	** Strainer w supporting housing
2	WD705.2205	* Coupling 15mm, brass
3	WD46778.31	* Pipe
4	WD46779.31	* Bracket
5	WD705.0915	* Coupling 302-15xr15
	WD705.0405	** Clamping sleeve
	WD705.0205	** Nut LK 63-15
6	WD729.1540	* Solenoid valve, housing EVSI-12
7	WD709.0809	* Ball valve
8	WD46928.31	Connection valve packet
9	WD706.0915	* L-coupling
10	WD301773.02	* Valve packet 301773
11	WD45234.31	Marksign "FILTER"
12	WD701.0122	Packing 1/2"

1.13 Emptying pump (option) vsezip.ru

+7(812)987-08-81

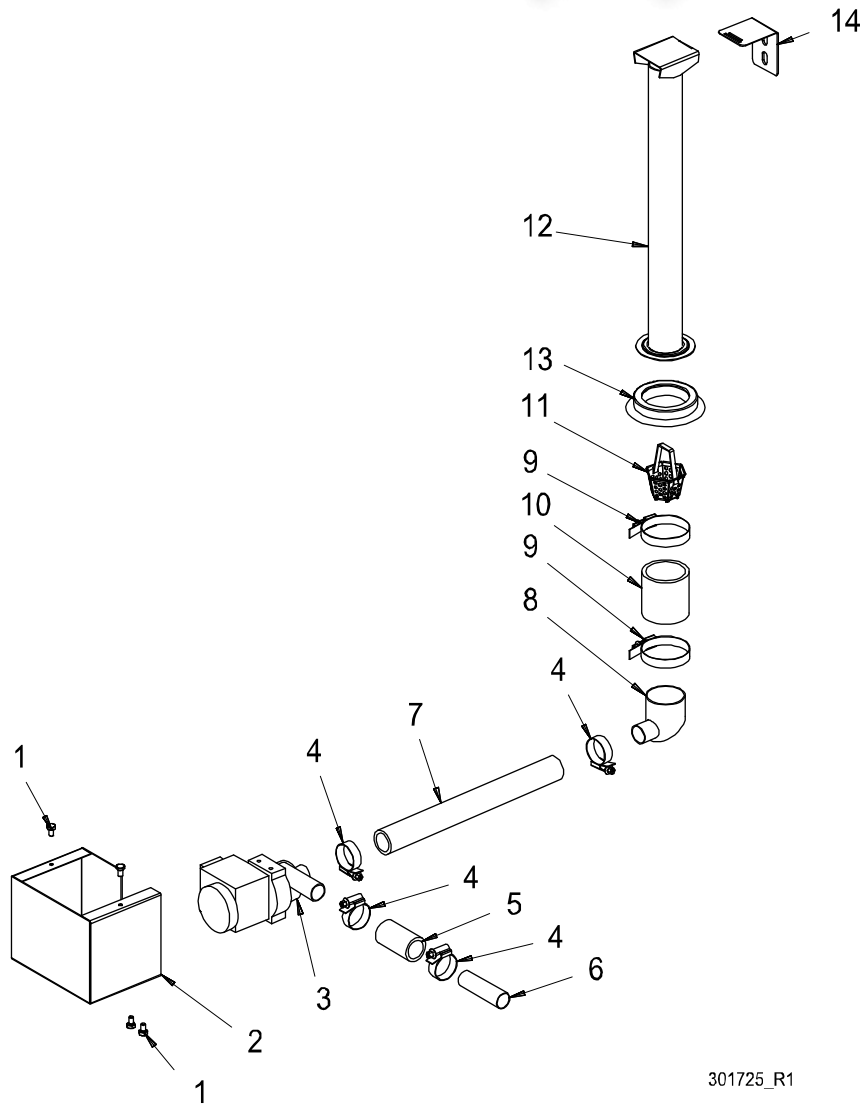

301725_R1

Emptying pump (option)		
Pos	WD no	Description
1	WD700.0111	Screw M6S M6x10 A2
2	WD300636.31	Cover emptying pump
3	WD735.0310	Emptying pump
4	WD714.0107	Hose clamp
5	WD717.0125	Radiator hose 25 L=60mm
6	WD04703.31	Pump connection empt.pump
7	WD717.0125	Radiator hose 25 L=290mm
8	WD04224.01	Drain connection empt.pump
9	WD714.0111	Hose clamp 50-70 mm
10	WD717.0150	Radiator hose ø50 L=60mm
11	WD44952.01	Outlet strainer
12	WD301029.01	Level pipe
13	WD719.4036	Level pipe sealing
14	WD45983.31	Attachment level pipe

1.14 Breaktank (option)

vsezip.ru

+7(812)987-08-81

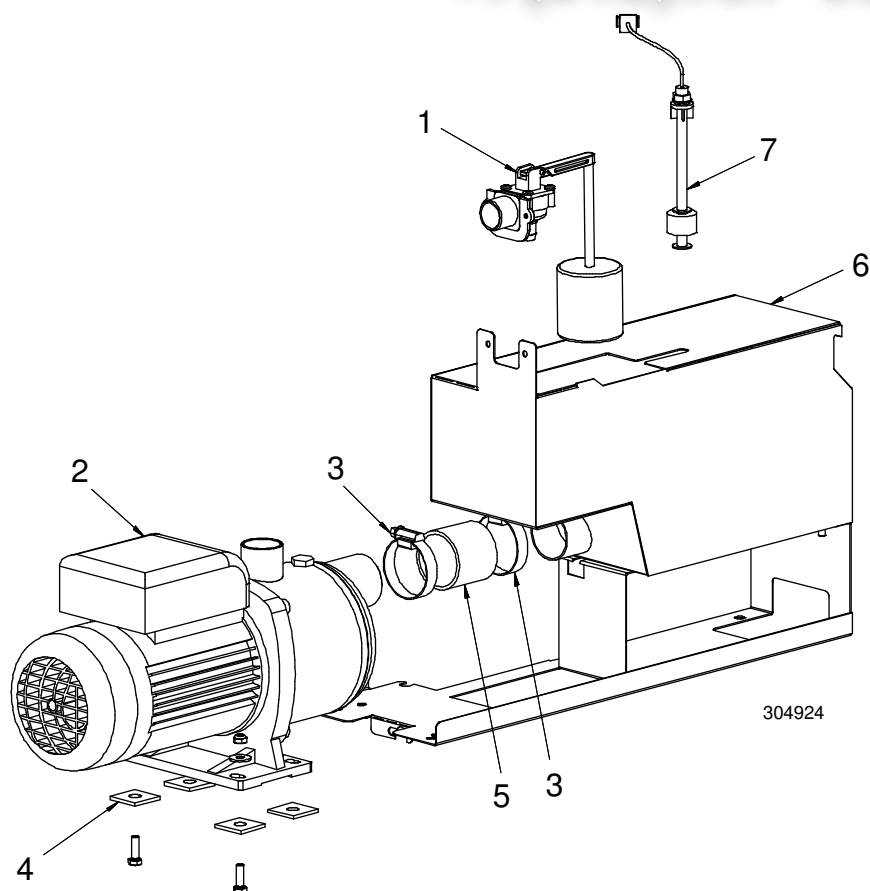

Breaktank (option)		
Pos	WD no	Description
1	WD709.4020	Float
2		Pump 2HM4T/A
3	WD714.0109	Hose clamp
4	WD719.1330	Rubber foot 30x30x3
5	WD46934.31	Rubber connection breaktank pump
6	WD303194.01	Tank cpl, Break tank
7	WD733.0514	Level guard

1.15 Backflow prevention device (option)

+7(812)987-08-81

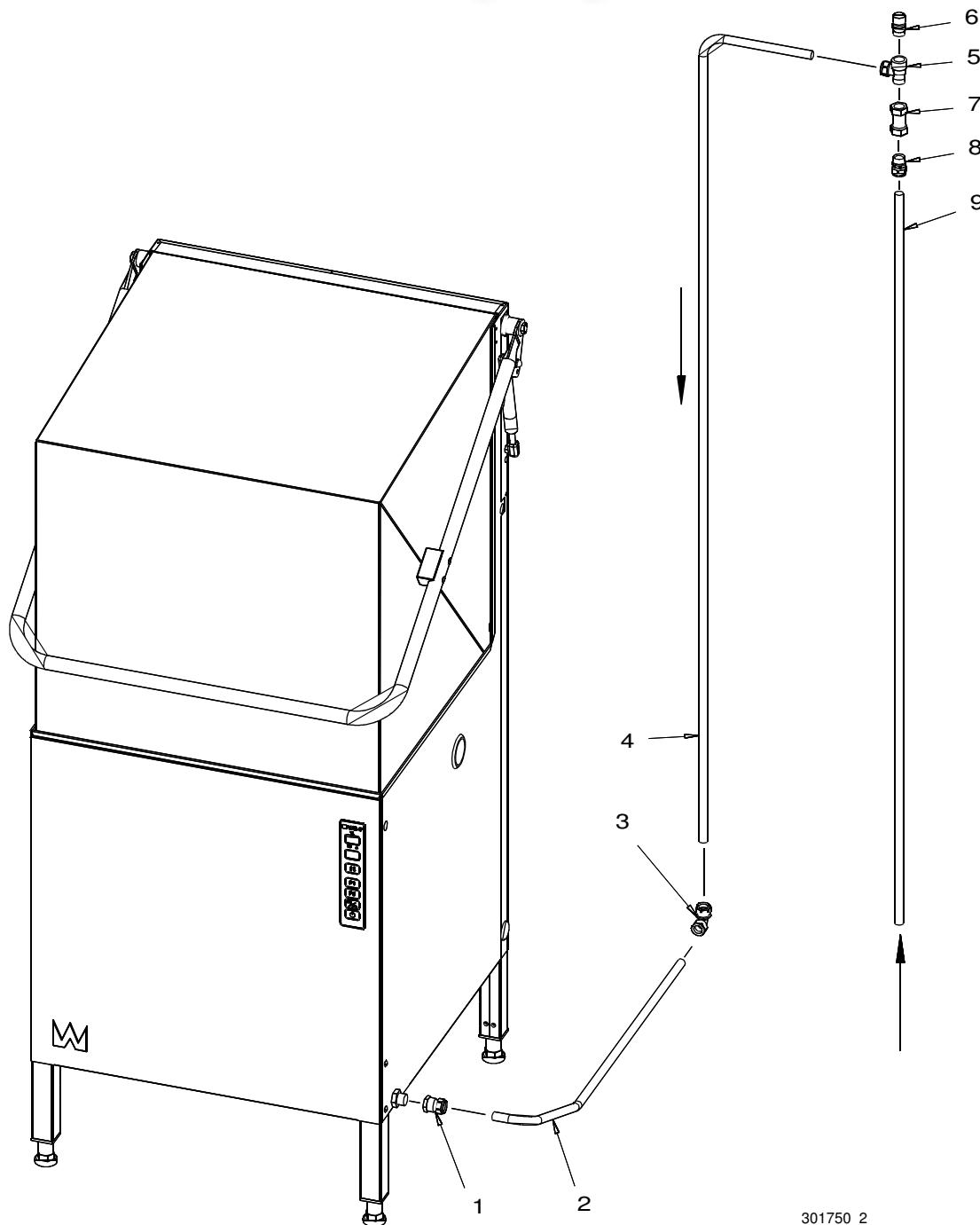

301750_2

Backflow prevention device (option)		
Pos	WD no	Description
1	WD705.1008	Coupling 15xR15
	WD705.0420	* Clamping sleeve 15mm
	WD705.0316	* Nut 15mm
2	WD31711.75	Pipe
3	WD705.1607	Coupling, angeled 1/2" x 15
	WD705.0420	* Clamping sleeve 15mm
	WD705.0316	* Nut 15mm
4	WD31712.75	Pipe
5	WD705.2703	T-coupling 15x15x R15
	WD705.0420	* Clamping sleeve 15mm
	WD705.0316	* Nut 15mm
6	WD709.1506	Vacuum valve
7	WD709.6305	Non return valve
8	WD705.0912	Coupling 15x15
	WD705.0420	* Clamping sleeve 15mm
	WD705.0316	* Nut 15mm
9	WD40249.75	Pipe

1.16 Support for bakery plates (option)

+7(812)987-08-81

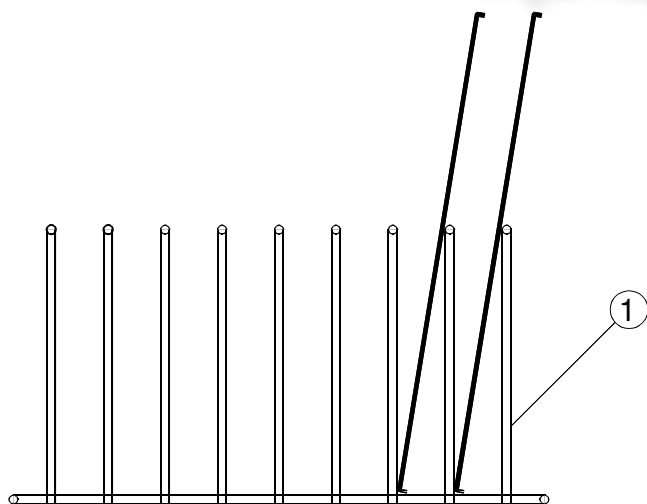

203,0733

Support for bakery plates (option)		
Pos	WD no	Description
	WD741.7011	Support for bakery plates

1.17 Rebuilding kit 460 basket (option)

+7(812)987-08-81

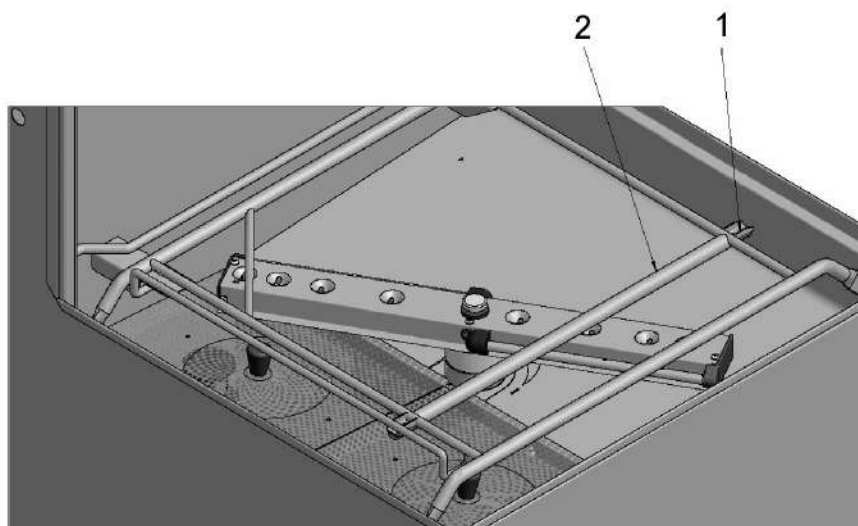

741,7011r1

Rebuilding kit 460 basket (option)		
Pos	WD no	Description
	WD741.7011	Rebuilding kit 460 basket
1	WD46633.31	* Attachment support 400 basket
2	WD46626.31	* Support basket frame rail 400 basket

1.18 Heat recovery by the exhausted steam (option)

+7(812)987-08-81

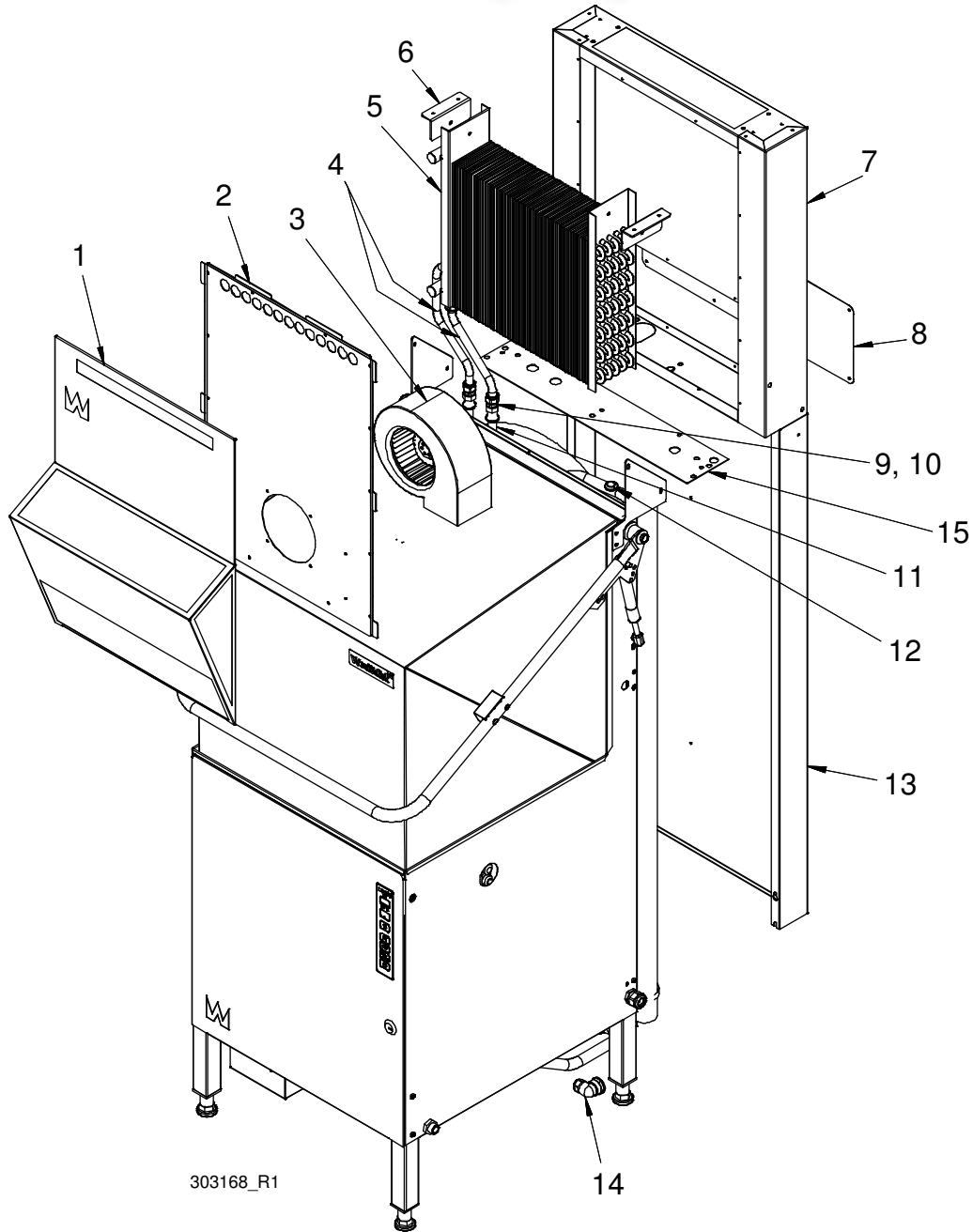

303168_R1

Heat recovery by the exhausted steam (201303)		
Pos	WD no	Description
1	WD303033.31	Outer plate steam cap
2	WD303030.31	Mounting plate fan
3	WD738.2023	Fan RFE 140CKU 230/50Hz 129W
4	WD918.0115	Pipe PEX 15x2.5 L=1m
5	WD810.0907	Condensing battery
6	WD46748.31	Anchor plate condensing battery
7	WD27825.01	Box steam cap WD-6
8	WD46802.31	Cover plate
9	WD705.0914	Coupling 15x15
	WD705.0420	* Clamping sleeve 15mm
	WD705.0315	* Nut 15mm
10	WD705.0104	Supporting sleeve 15x2.5
11	WD719.5026	Tube EPDM+RFR, G1/2" L=2000
12	WD719.1219	Conduit entry
13	WD27802.31	Rear plate WD-6
14	WD705.1905	Coupling angeled 15 x 3/4"
	WD705.0420	* Clamping sleeve 15mm
	WD705.0315	* Nut 15mm
15	WD305297.31	Gasket

1.19 Heat recovery by the drain water (option)

+7(812)987-08-81

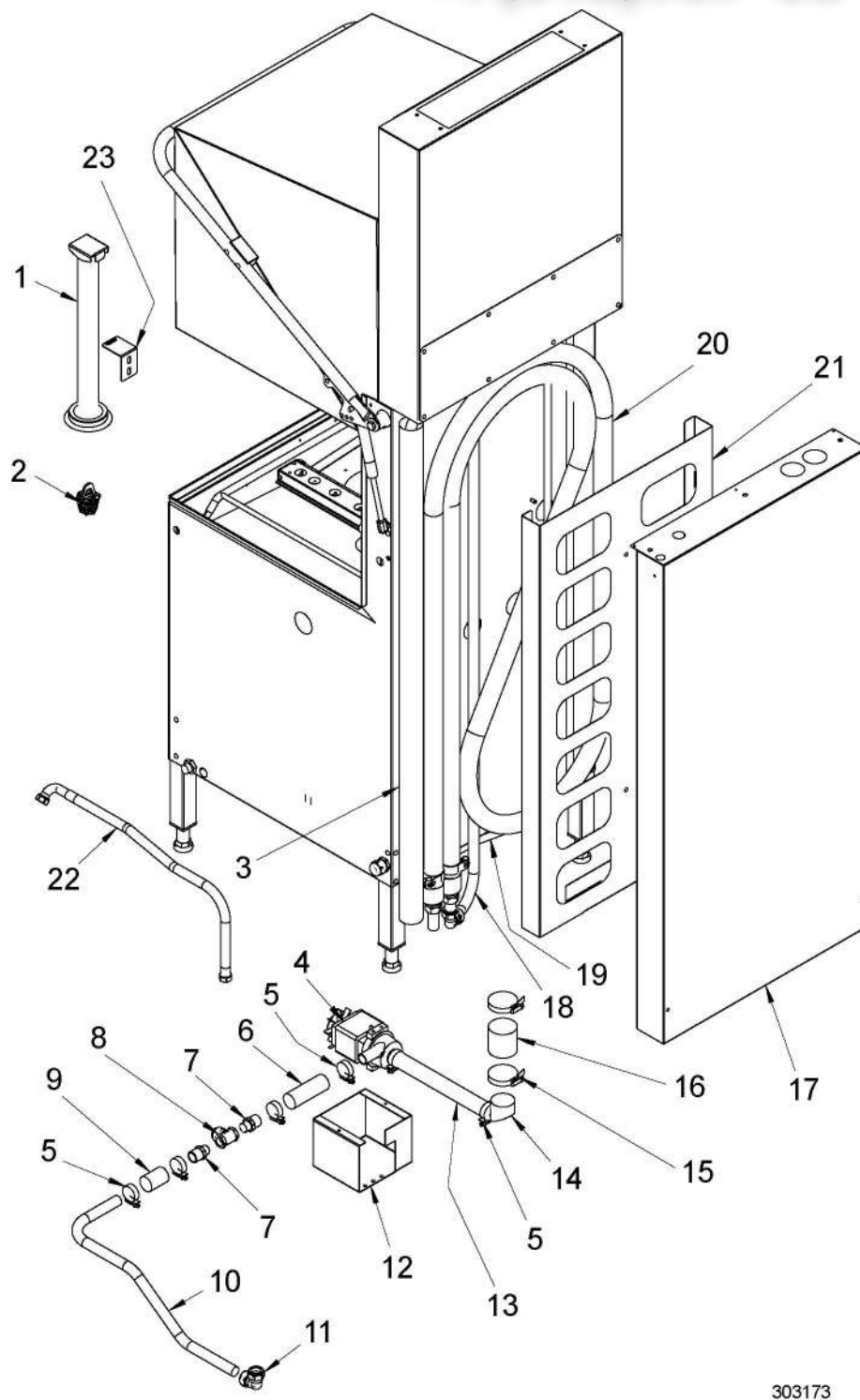

303173

Heat recovery by the drain water (option)		
Pos	WD no	Description
1	WD301029.01	Level pipe
	WD719.4036	* Level pipe sealing
2	WD44952.01	Outlet strainer
3	WD726.0850	Pipe 50x3000 without muff PP L=1260
4	WD735.0202	Drainpump Hanning BE 55C 9
5	WD714.0107	Hose clamp
6	WD717.0125	Radiator hose 25 L=130
7	WD706.1810	Hose nipple1/2"
8	WD709.0561	Flap non return valve TYP 130, 1/2"
9	WD717.0125	Radiator hose 25 L=50
10	WD46760.31	Pipe drain pump
11	WD705.1207	Coupling 22mm
	WD705.0323	* Clamping sleeve 22mm
	WD705.0322	* Nut 22 mm
12	WD300636.31	Cover emptying pump
13	WD717.0125	Radiator hose 25 L=270
14	WD04224.01	Drain connection empt.pump
15	WD714.0111	Hose clamp 50-70 mm
16	WD717.0150	Radiator hose ø50 L=60
17	WD27802.31	Rear plate WD-7
18	WD303013.31	Pipe drain heat recover
19	WD719.5026	Tube EPDM+RFR, G1/2" L=2000
20	WD303008.01	Heat recovery, cpl
	WD714.0603	* Hose clamp PA-RI 39-45
	WD40058.31	* Distribution nipple
	WD303064.01	* Heat recovery
	WD705.0917	* Coupling 22xR20
	WD705.0323	** Clamping sleeve 22mm
	WD705.0322	** Nut 22 mm
21	WD303191.31	Attachment
22	WD719.5025	Tube RFR G1/2" L=800
23	WD45983.31	Attachment level pipe

1.20 Pump 1225

vsezip.ru

+7(812)987-08-81

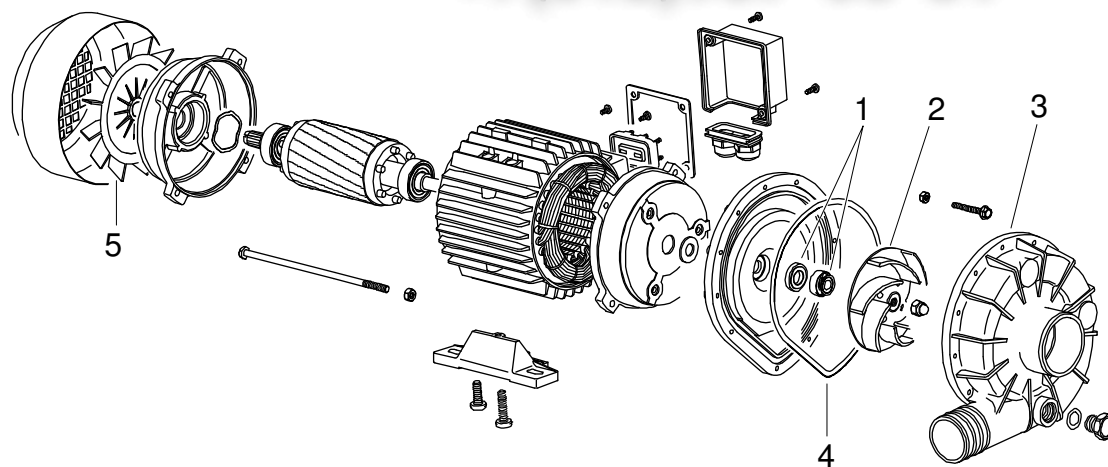

805.2610

Pump 1225		
Pos	WD no	Description
	WD301169.01	Pump 230/400V 50Hz
	WD805.2610A	Pump 255-480/440-480V 60Hz
	WD805.2610E	Pump 200V 50Hz
	WD805.2610F	Pump 200V 60Hz
1	WD805.2554	* Sealing
2	WD805.2613	* Impeller 50Hz
2	WD805.2613A	* Impeller 60Hz
3	WD805.2611	* Pumphouse
4	WD805.2555	* O-ring 50Hz
5	WD805.2572	* Fan

1.21 Pump 2HM4T/A

vsezip.ru

+7(812)987-08-81

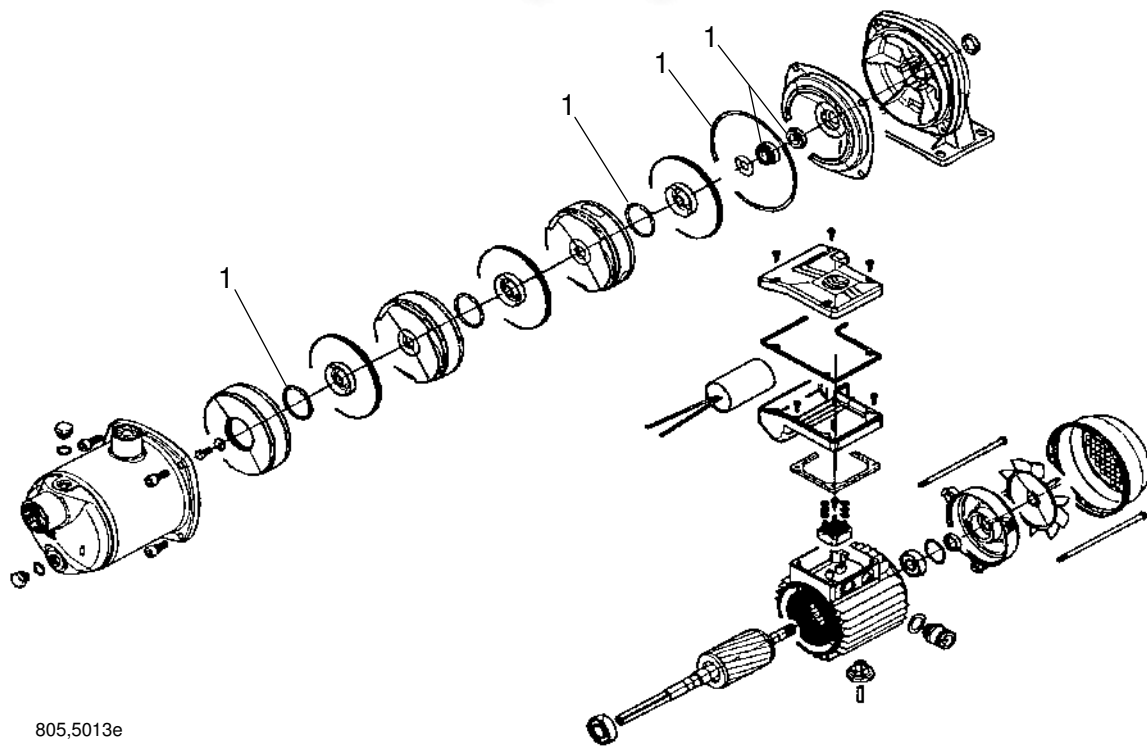

805,5013e

Pump 2HM4T/A		
Pos	WD no	Description
	WD805.5013	Pump 2HM4T/A 230/415V/3/50Hz
	WD805.5013A	Pump 2HM4T/A 440V/3/60Hz
	WD805.5013B	Pump 2HM46T/A+MP 230/400V/60Hz
	WD805.5013D	Pump 2HM46T 230/415V/60Hz
	WD805.5013E	Pump 2HM4T/A 200V/3/50Hz
	WD805.5013F	Pump 2HM4T/A 200V/3/60Hz
1	WD805.5014	Mechanical seal + OR

vsezip.ru

+7(812)987-08-81