

**Зип Общепит**

**vsezip.ru**

**DESPIECE TECNICO**

**+7(812)987-08-81**

**Lavavajillas de arrastre compactos  
Lave-vaisselle d' avancement compacts  
Rack compact conveyor dishwasher  
Compact korbtransport geschirrspüler  
Lavastoviglie a trascinamento compatte  
Lava-louças de arrat্রে compacto**

**Modelos:**

**FI-160**

**FI-200**

**ECO-160**

**ECO-200**

***Octubre 2008 October***

***Revisado Agosto 2010***



**Fagor Industrial**

Зип Общепит

sezip.ru

+7(812)987-08-81

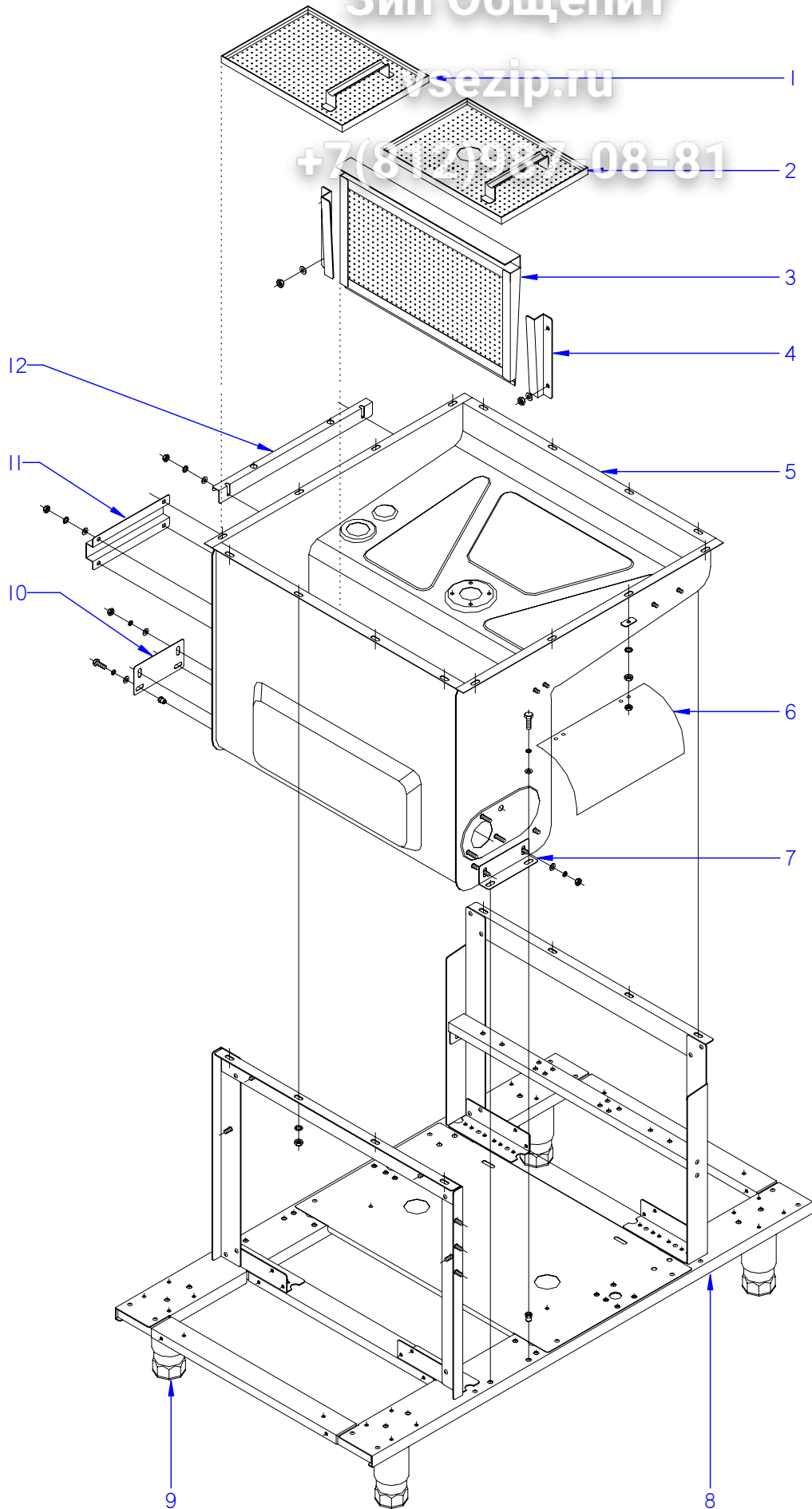

ITEM MARCADO EN COLOR = REPUESTO RECOMENDADO  
COLOURED ITEM = RECOMMENDED SPARE PART

N plano	Firma	Fecha	Aparato	ARMAZON Y CUBA	Lamina	Fagor Industrial S.Coop. <b>FAGOR</b>
C-2120	<i>(Signature)</i>	2008-10	LAVAVAJILLAS COMPACTOS	1	Oñate	

<b>MOD.</b>	<b>LAVAVAJILLAS COMPACTOS COMPACT DISHWASHERS</b>	<b>ZONA</b>	<b>ARMAZON Y CUBA / TUB AND FRAME</b>
-------------	---	-------------	---------------------------------------

ITEM	CODIGO	DENOMINACION	TEXTO	FI-160 ECO-160	FI-200 ECO-200	FI-200 W		
1	Z270803000	BANDEJA POSTERIOR COMPLETA	COMPLETE REAR TRAY	1	1	1		
2	Z270801000	BANDEJA ANTERIOR COMPLETA	COMPLETE FRONT TRAY	1	1	1		
3	Z710907000	FILTRO COMPLETO	COMPLETE FILTER	1	1	1		
4	Z710309000	GUIA FILTRO ANTERIOR	FRONT FILTER GUIDE	1	1	1		
S/Nº	Z710310000	GUIA FILTRO POSTERIOR	REAR FILTER GUIDE	1	1	1		
	Q262040000	ARANDELA GROW. A6 A.304	WASHER GROW. A6 A.304	12	12	12		
	Q162040000	TUERCA EXAGONAL M6	HEXAGONAL NUT M6	12	12	12		
	Q012042000	TORNILLO EXAGONAL M6X15	HEXAGONAL BOLT M6x15	4	4	4		
5	Z270320000	CUBA SOLDADA	WELDED TUB	1	1	1		
	Z310341000	ARANDELA RECTANGULAR	RECTANGULAR WASHER	16	16	16		
	Q262040000	ARANDELA GROW. A6 A.304	WASHER GROW. A6 A.304	16	16	16		
	Q162040000	TUERCA EXAGONAL M6	HEXAGONAL NUT M6	16	16	16		
6	Z313041000	CUBIERTA COMPONENTES	COMPONENT COVER	2	2	2		
7	Z270324000	AMARRE CUBA ANTERIOR	FRONT TUB FASTENING	1	1	1		
8	Z270101000	ARMAZON MONTADO	FRAME MOUNTED	1	1	-		
8	Z270123000	ARMAZON W MONTADO	FRAME W MOUNTED	-	-	1		
	Q232040000	ARANDELA A6	WASHER A6	4	4	4		
	Q262030000	ARANDELA GROW. A5 A.304	WASHER GROW. A5 A.304	4	4	4		
	Q212031000	TUERCA SOMBRERETE M5	COWL NUT M5	4	4	4		
	Q232040000	ARANDELA A6	WASHER A6	8	8	8		
9	X260151000	PATA REGULABLE	ADJUSTABLE LEG	4	4	4		
10	Z270325000	AMARRE CUBA POSTERIOR	REAR TUB FASTENING	1	1	1		
11	Z281111000	PROTECTOR MANGUERA ECO	ECO HOSE PROTECTOR	1	1	1		
12	Z272907000	SOPORTE PANEL	PANEL SUPPORT	1	1	1		
	Q152004000	TORNILLO APLASTADO M5x13 A304	FLAT HEADED BOLT M5x13 A304	10	10	10		
	Q262030000	ARANDELA GROW. A5 A.304	WASHER GROW. A5 A.304	10	10	10		
	Q232040000	ARANDELA A6	WASHER A6	12	12	12		
	Q162040000	TUERCA EXAGONAL M6	HEXAGONAL NUT M6	2	2	2		
	Q262040000	ARANDELA GROW. A6 A.304	WASHER GROW. A6 A.304	2	2	2		

Зип Общепит

vsezip.ru

+7(812)987-08-81

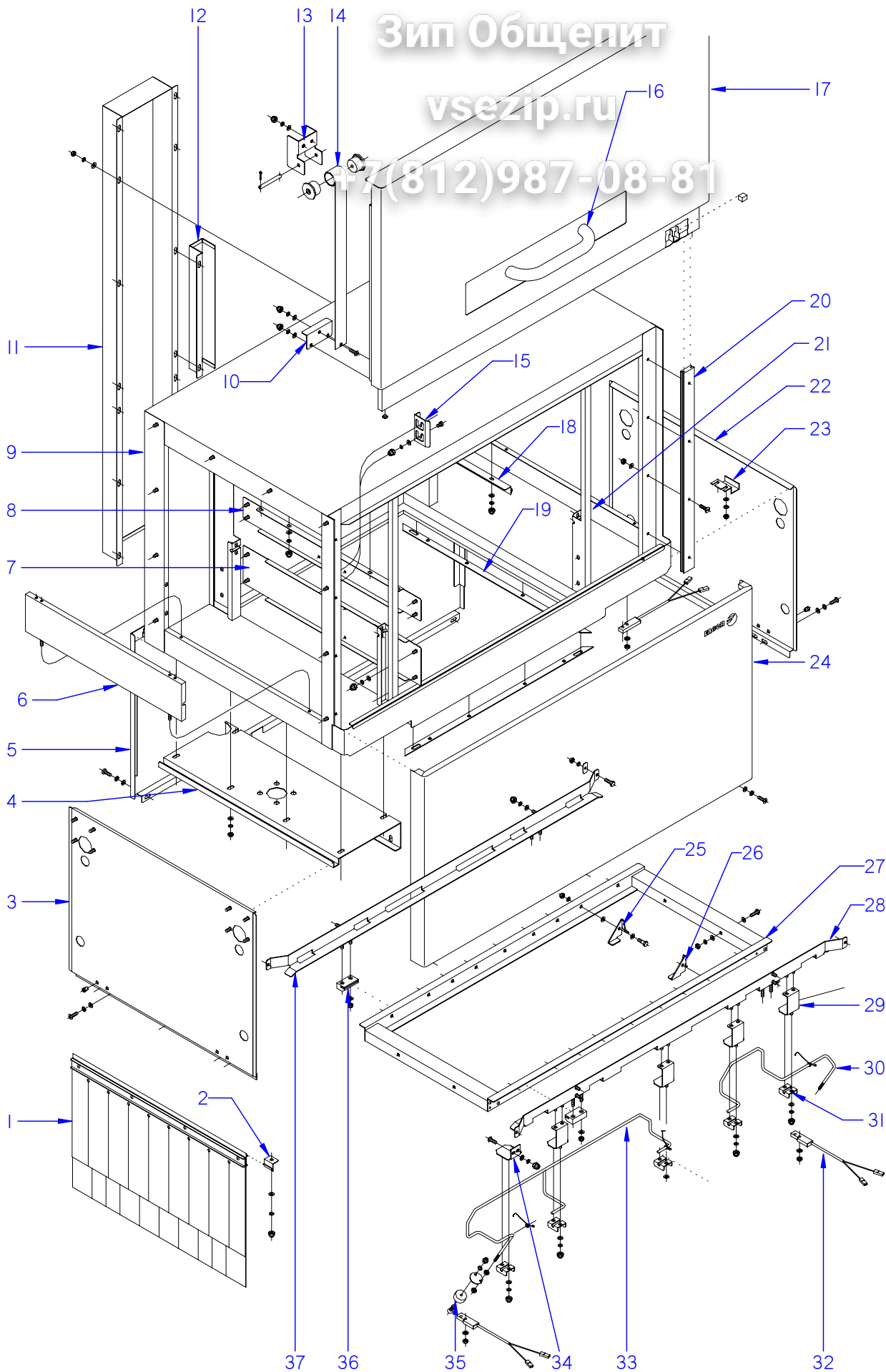

ITEM MARCADO EN COLOR = REPUESTO RECOMENDADO  
COLOURED ITEM = RECOMMENDED SPARE PART

N plano	Firma	Fecha	Aparato	TUNEL DE LAVADO Y ACLARADO	Lamina	Fagor Industrial S.Coop. <b>FAGOR</b>
C-2121	<i>[Signature]</i>	2008-10	LAVAVAJILLAS COMPACTOS		2	Oñate

MOD.		LAVAVAJILLAS COMPACTOS COMPACT DISHWASHERS		ZONA		TUNEL DE LAVADO Y ACLARADO WASH AND RINSE TUNNEL				
ITEM	CODIGO	DENOMINACION	TEXTO	FI-160 I ECO-160 I	FI-160 D ECO-160 D	FI-200 I ECO-200 I	FI-200 D ECO-200 D	FI-200 W I		
1	Z276429000	CORTINA INTERIOR COMPLETA	COMPLETE INTERIOR CURTAIN	2	2	2	2	2		
	Z276419000	CORTINA EXTERIOR COMPLETA	COMPLETE EXTERIOR CURTAIN	2	2	2	2	2		
	Z270326000	SUJECION CORTINA	CURTAIN FASTENING	4	4	4	4	4		
	Q232040000	ARANDELA A6	WASHER A6	4	4	4	4	4		
	Q262030000	ARANDELA GROW. A5 A.304	WASHER GROW. A5 A.304	4	4	4	4	4		
	Q212031000	TUERCA SOMBRERETE M5	COWL NUT M5	4	4	4	4	4		
3	Z272936000	PANEL LATERAL	SIDE PANEL	1	1	1	1	1		
	Z270341000	REFUERZO SOPORTE COMPL.	COMPL. SUPPORT REINFORCEM	1	1	1	1	1		
	Q232040000	ARANDELA A6	WASHER A6	8	8	8	8	8		
	Q262040000	ARANDELA GROW. A6 A.304	WASHER GROW. A6 A.304	8	8	8	8	8		
	Q162040000	TUERCA EXAGONAL M6	HEXAGONAL NUT M6	8	8	8	8	8		
	Z272935000	PANEL POSTERIOR COMPLETO	COMPLETE REAR PANEL	1	1	1	1	1		
5	Z272938000	PANEL POSTERIOR COMPLETO	COMPLETE REAR PANEL	1	1	1	1	1		
6	Z270337000	SUPLEMENTO COMPLETO	COMPLETE SUPPLEMENT	1	1	1	1	1		
	Z270343000	SUPLEMENTO COMPLETO W	COMPLETE SUPPLEMENT W	-	-	-	-	2		
	Q232040000	ARANDELA A6	WASHER A6	4	4	4	4	8		
	Q212031000	TUERCA SOMBRERETE M5	COWL NUT M5	4	4	4	4	8		
	Q152004000	TORNILLO APLASTADO M5x13 A304	FLAT HEADED BOLT M5x13 A304	2	2	2	2	4		
	Q262030000	ARANDELA GROW. A5 A.304	WASHER GROW. A5 A.304	4	4	4	4	8		
7	Z270330000	INFERIOR PORTICO COMPLETO	COMPLETE LOWER GANTRY	2	2	2	2	2		
	Q232040000	ARANDELA A6	WASHER A6	4	4	4	4	4		
	Q212031000	TUERCA SOMBRERETE M5	COWL NUT M5	4	4	4	4	4		
	Q262030000	ARANDELA GROW. A5 A.304	WASHER GROW. A5 A.304	4	4	4	4	4		
	8	Z270332000	SUPERIOR PORTICO COMPLETO	COMPLETE UPPER GANTRY	2	2	2	2	2	
		Q232040000	ARANDELA A6	WASHER A6	9	9	9	9	9	
Q212031000		TUERCA SOMBRERETE M5	COWL NUT M5	9	9	9	9	9		
	Q262030000	ARANDELA GROW. A5 A.304	WASHER GROW. A5 A.304	9	9	9	9	9		
	9	Z270351000	CAJA SOLDADA	WELDED BOX	1	1	1	1	1	

MOD.		LAVAVAJILLAS COMPACTOS COMPACT DISHWASHERS		ZONA	TUNEL DE LAVADO Y ACLARADO WASH AND RINSE TUNNEL				
ITEM	CODIGO	DENOMINACION	TEXTO	FI-160 I ECO-160 I	FI-160 D ECO-160 D	FI-200 I ECO-200 I	FI-200 D ECO-200 D	FI-200 W I	
10	Z270515000	AMARRE RESORTE	SPRING FASTENING	2	2	2	2	2	
10	Z270517000	AMARRE RESORTE	SPRING FASTENING	2	2	2	2	2	
	Q152004000	TORNILLO APLASTADO M5x13 A304	FLAT HEADED BOLT M5x13 A304	2	2	2	2	2	
	Q262030000	ARANDELA GROW. A5 A.304	WASHER GROW. A5 A.304	6	6	6	6	6	
	Q232040000	ARANDELA A6	WASHER A6	6	6	6	6	6	
	Q212031000	TUERCA SOMBRERETE M5	COWL NUT M5	6	6	6	6	6	
11	Z313049000	CUBIERTA POST.CUADRO ELECT.	ELECT. PANEL REAR COVER	1	1	1	1	1	
	Q232040000	ARANDELA A6	WASHER A6	34	34	34	34	34	
	Q262040000	ARANDELA GROW. A6 A.304	WASHER GROW. A6 A.304	34	34	34	34	34	
	Q162040000	TUERCA EXAGONAL M6	HEXAGONAL NUT M6	16	16	16	16	16	
	Q212040000	TUERCA SOMBRERETE M6	COWL NUT M6	14	14	14	14	14	
12	Z273046000	GUIA TOMA CORRIENTE	POWER SOCKET GUIDE	-	-	-	-	-	
13	Z270511000	SOPORTE RESORTE	SPRING SUPPORT	2	2	2	2	2	
	Z270514000	EJE RESORTE	SPRING SHAFT	2	2	2	2	2	
	Q352001000	PASADOR DE ALETAS 2X20	COTTER PIN 2X20	4	4	4	4	4	
	Q232040000	ARANDELA A6	WASHER A6	4	4	4	4	4	
	Q262030000	ARANDELA GROW. A5 A.304	WASHER GROW. A5 A.304	4	4	4	4	4	
	Q212031000	TUERCA SOMBRERETE M5	COWL NUT M5	4	4	4	4	4	
14	Z270513000	RESORTE FUERZA CONSTANTE	CONSTANT FORCE SPRING	2	2	2	2	2	
	Z270512000	ENCAJE RESORTE	SPRING SOCKET	4	4	4	4	4	
15	Z270531000	SUJECION PUERTA	DOOR FASTENING	1	1	1	1	1	
S/Nº	Z510556000	SOPORTE ENGANCHE PUERTA	SUPPORT DOOR LATCH	1	1	1	1	1	
S/Nº	Z510550000	ENGANCHE PUERTA COMPLETO	FULL DOOR HOOK	1	1	1	1	1	
	Q212031000	TUERCA SOMBRERETE M5	COWL NUT M5	2	2	2	2	2	
16	Z200550000	ASA PUERTA COMPLETA	COMPLETE DOOR HANDLE	1	1	1	1	1	
	Q308007000	ARANDELA DUBO 5	WASHER DUBO 5	2	2	2	2	2	
	Q162030000	TUERCA EXAGONAL M5	HEXAGONAL NUT M5	2	2	2	2	2	
17	Z270501000	PUERTA MONTADA	FITTED DOOR	1	1	1	1	1	
	Z270516000	TOPE	STOP	2	2	2	2	2	
	Z200506000	IMAN	MAGNET	1	1	1	1	1	
S/Nº	Z276122000	CHECK LIST ARRASTRE FAGOR	CHECK LIST	1	1	1	1	1	

MOD.		LAVAVAJILLAS COMPACTOS COMPACT DISHWASHERS		ZONA		TUNEL DE LAVADO Y ACLARADO WASH AND RINSE TUNNEL				
ITEM	CODIGO	DENOMINACION	TEXTO	FI-160 I ECO-160 I	FI-160 D ECO-160 D	FI-200 I ECO-200 I	FI-200 D ECO-200 D	FI-200 W I		
18	Z270327000	APOYO CORTINA	CURTAIN SUPPORT	1	1	1	1	1		
	Q262030000	ARANDELA GROW. A5 A.304	WASHER GROW. A5 A.304	3	3	3	3	3		
	Q232040000	ARANDELA A6	WASHER A6	3	3	3	3	3		
	Q212031000	TUERCA SOMBRERETE M5	COWL NUT M5	3	3	3	3	3		
19	Z270334000	PERFIL	PROFILE	4	4	4	4	4		
20	Z270336000	GUIA PUERTA	DOOR GUIDE	2	2	2	2	2		
	Q152045000	TORNILLO AMARRE M6X25	FASTENING BOLT M6X25	8	8	8	8	8		
	Q232040000	ARANDELA A6	WASHER A6	8	8	8	8	8		
	Q222012000	TUERCA AUTOBLOCANTE M6	SELF-LOCKING NUT M6	8	8	8	8	8		
21	Z270329000	FRONTAL PORTICO DERECHO	RIGHT GANTRY FRONT	1	1	1	1	1		
S/Nº	Z270328000	FRONTAL PORTICO IZQUIERDO	LEFT GANTRY FRONT	1	1	1	1	1		
	Q212031000	TUERCA SOMBRERETE M5	COWL NUT M5	2	2	2	2	2		
	Q262030000	ARANDELA GROW. A5 A.304	WASHER GROW. A5 A.304	2	2	2	2	2		
	Q232040000	ARANDELA A6	WASHER A6	2	2	2	2	2		
22	Z272936000	PANEL LATERAL	SIDE PANEL	1	1	1	1	1		
23	Z272906000	SUJECION PANELES	PANEL FASTENING	2	2	2	2	2		
24	Z272933000	PANEL FRONTAL COMPLETO	COMPLETE FRONT PANEL	1	1	1	1	1		
25	Z275078000	UÑA ARRASTRE DERECHA LASER	LASER RIGHT DRAG CLAW	9	9	9	9	9		
26	Z275077000	UÑA ARRASTRE IZQUIERDA LASER	LASER LEFT DRAG CLAW	9	9	9	9	9		
	Q232050000	ARANDELA A8	WASHER A8	36	36	36	36	36		
	Q152046000	TORNILLO EXAGON. CON CUELLO	HEXAGONAL BOLT. WITH NECK	18	18	18	18	18		
	Q232040000	ARANDELA A6	WASHER A6	18	18	18	18	18		
	Q222012000	TUERCA AUTOBLOCANTE M6	SELF-LOCKING NUT M6	18	18	18	18	18		
27	Z275051000	SOPORTE UÑAS DE LAVADO	WASH CLAW SUPPORT	1	1	1	1	1		
28	Z275065000	GUIA LAVADO ANTER. IZQUIERDO	LEFT FRONT WASH GUIDE	1	—	1	—	1		
28	Z275066000	GUIA LAVADO ANTER. DERECHO	RIGHT FRONT WASH GUIDE	—	1	—	1	—		
29	Z271211000	"U" SOPORTE PULSADORES	BUTTON U SUPPORT	4	4	4	4	4		
	Q262030000	ARANDELA GROW. A5 A.304	WASHER GROW. A5 A.304	8	8	8	8	8		
	Q232040000	ARANDELA A6	WASHER A6	8	8	8	8	8		
	Q212031000	TUERCA SOMBRERETE M5	COWL NUT M5	8	8	8	8	8		

MOD.		LAVAVAJILLAS COMPACTOS COMPACT DISHWASHERS		ZONA		TUNEL DE LAVADO Y ACLARADO WASH AND RINSE TUNNEL				
ITEM	CODIGO	DENOMINACION	TEXTO	FI-160 I ECO-160 I	FI-160 D ECO-160 D	FI-200 I ECO-200 I	FI-200 D ECO-200 D	FI-200 W I		
30	Z271205000	PULSADOR ACLARADO IZQUIERD.	LEFT RINSE BUTTON	1	—	1	—	1		
S/Nº	Z271222000	PULSADOR ACLARADO DERECHO	RIGHT RINSE BUTTON	—	1	—	1	—		
	Z271203000	MUELLE TORS. IZDO 27601	LEFT TORS. SPRING 27601	2	2	2	2	2		
	Z271204000	MUELLE TORS. DCHO 27561	RIGHT TORS. SPRING 27561	2	2	2	2	2		
31	Z271201000	SOPORTE PULSADOR	BUTTON SUPPORT	4	4	4	4	4		
	Q262030000	ARANDELA GROW. A5 A.304	WASHER GROW. A5 A.304	8	8	8	8	8		
	Q232040000	ARANDELA A6	WASHER A6	8	8	8	8	8		
	Q212031000	TUERCA SOMBRERETE M5	COWL NUT M5	8	8	8	8	8		
32	Z100522000	INTERRUPTOR MAGNETICO AC	MAGNETIC SWITCH AC	3	3	3	3	3		
	Q242020000	ARANDELA ABANICO A4 A.304	FAN WASHER A4 A.304	6	6	6	6	6		
	Q162020000	TUERCA EXAGONAL M4	HEXAGONAL NUT M4	6	6	6	6	6		
33	Z271251000	PULSADOR LAVADO IZQUIERDO	LEFT WASH BUTTON	1	—	1	—	—		
33	Z271246000	PULSADOR LAVADO IZQUIERDO W	LEFT WASH BUTTON W	—	—	—	—	1		
33	Z271253000	PULSADOR LAVADO DERECHO	RIGHT WASH BUTTON	—	1	—	1	—		
33	Z271247000	PULSADOR LAVADO DERECHO W	RIGHT WASH BUTTON W	—	—	—	—	—		
34	Z271213000	ESCUADRA SOPORTE	SUPP. BRACKET	1	1	1	1	1		
	Q152004000	TORNILLO APLASTADO M5x13 A304	FLAT HEADED BOLT M5x13 A304	2	2	2	2	2		
	Q262030000	ARANDELA GROW. A5 A.304	WASHER GROW. A5 A.304	2	2	2	2	2		
	Q232040000	ARANDELA A6	WASHER A6	2	2	2	2	2		
	Q212031000	TUERCA SOMBRERETE M5	COWL NUT M5	2	2	2	2	2		
35	Z271207000	IMAN	MAGNET	2	2	2	2	2		
	Z271206000	SOPORTE IMAN	MAGNET BRACKET	2	2	2	2	2		
	Q072033000	TORN.G.S. M5X20 A304	BOLT G.S. M5X20 A304	2	2	2	2	2		
	Q212031000	TUERCA SOMBRERETE M5	COWL NUT M5	2	2	2	2	2		
	Q232030000	ARANDELA A5	WASHER A5	2	2	2	2	2		
	Q162040000	TUERCA EXAGONAL M6	HEXAGONAL NUT M6	4	4	4	4	4		
36	Z275075000	DESLIZAMIENTO GUIAS	GUIDE SLIDE	4	4	4	4	4		
	Q232040000	ARANDELA A6	WASHER A6	8	8	8	8	8		
	Q222012000	TUERCA AUTOBLOCANTE M6	SELF-LOCKING NUT M6	8	8	8	8	8		
	Q012042000	TORNILLO EXAGONAL M6X15	HEXAGONAL BOLT M6x15	4	4	4	4	4		
	Q262040000	ARANDELA GROW. A6 A.304	WASHER GROW. A6 A.304	4	4	4	4	4		



ITEM	CODIGO	DENOMINACION	TEXTO	TUNEL DE LAVADO Y ACLARADO WASH AND RINSE TUNNEL					
				FI-160 I ECO-160 I	FI-160 D ECO-160 D	FI-200 I ECO-200 I	FI-200 D ECO-200 D	FI-200 W I	
37	Z275034000	GUIA POSTERIOR LAVADO	REAR WASH GUIDE	1	1	1	1	1	
	Z310341000	ARANDELA RECTANGULAR	RECTANGULAR WASHER	4	4	4	4	4	
	Q162040000	TUERCA EXAGONAL M6	HEXAGONAL NUT M6	4	4	4	4	4	
	Q232040000	ARANDELA A6	WASHER A6	8	8	8	8	8	
	Q212031000	TUERCA SOMBRERETE M5	COWL NUT M5	8	8	8	8	8	
	Q262030000	ARANDELA GROW. A5 A.304	WASHER GROW. A5 A.304	8	8	8	8	8	

Зип Общепит

vsezip.ru

+7(812)987-08-81

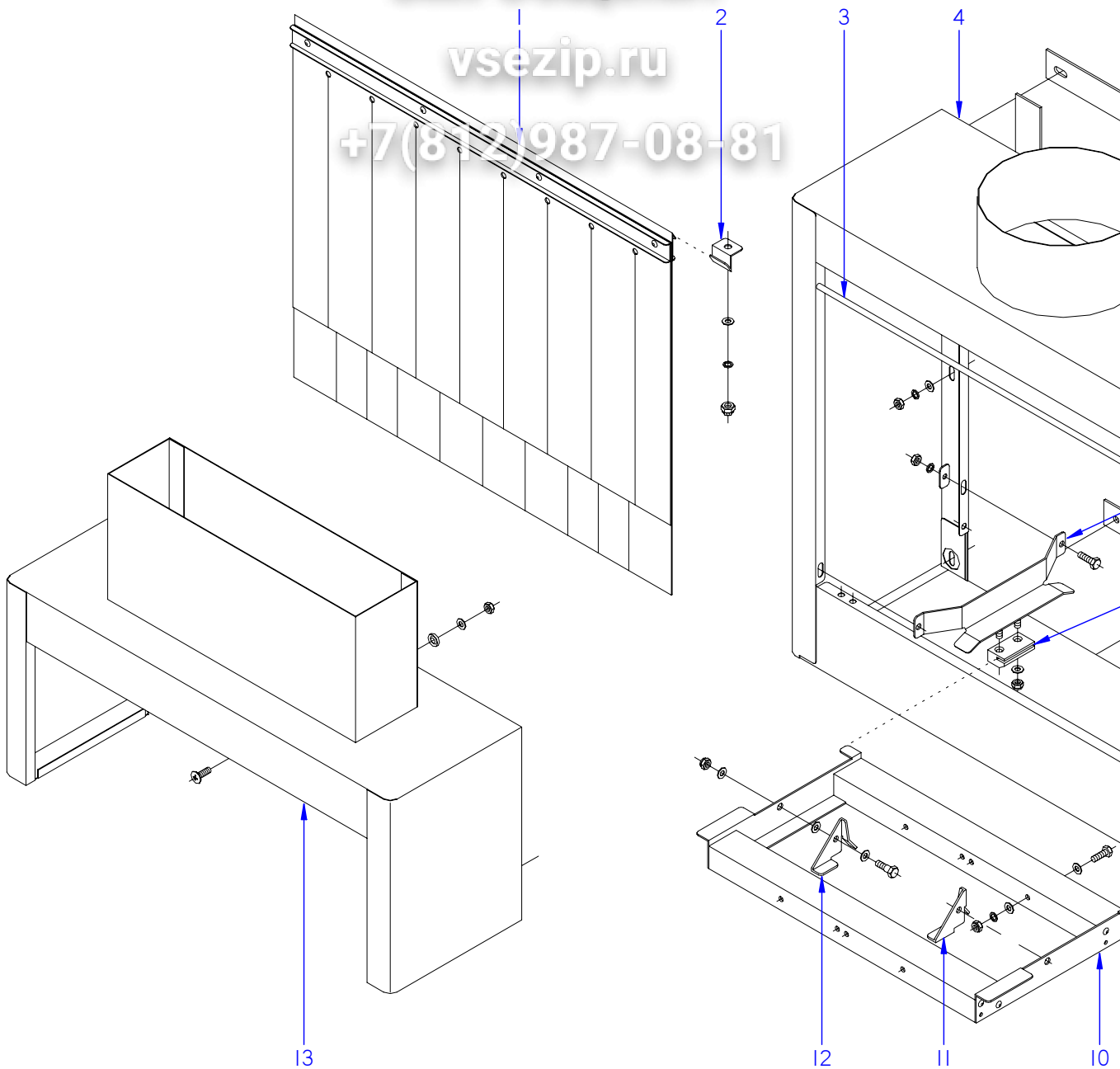

ITEM MARCADO EN COLOR = REPUUESTO RECOMENDADO  
COLOURED ITEM = RECOMMENDED SPARE PART

N plano	Firma	Fecha	Aparato	Lamina	Fagor Industrial S. Coop.
C-2122	<i>(Signature)</i>	2008-10	LAVAVAJILLAS COMPACTOS	3	Onete
TUNEL ASPIRADOR DE VAHOS					
<b>FAGOR</b>					

MOD.		LAVAVAJILLAS COMPACTOS COMPACT DISHWASHERS		ZONA		TUNEL ASPIRADOR DE VAHOS STEAM INTAKE TUNNEL	
ITEM	CODIGO	DENOMINACION	TEXTO	FI-160 ECO-160	FI-200 ECO-200	FI-200 W	
1	Z276419000	CORTINA EXTERIOR COMPLETA	COMPLETE EXTERIOR CURTAIN	2	2	2	
	Q302022000	ARANDELA 16X6X1.2 A.304	WASHER 16X6X1.2 A.304	12	12	12	
	Q262040000	ARANDELA GROW. A6 A304	WASHER GROW. A6 A304	12	12	12	
	Q162040000	TUERCA EXAGONAL M6	HEXAGONAL NUT M6	12	12	12	
2	Z270326000	SUJECION CORTINA	CURTAIN FASTENING	2	2	-	
	Q262040000	ARANDELA GROW. A6 A.304	WASHER GROW. A6 A.304	2	2	-	
	Q232040000	ARANDELA A6	WASHER A6	2	2	-	
	Q212040000	TUERCA SOMBRERETE M6	COWL NUT M6	2	2	-	
3	Z276520000	PROTECTOR SUPER. SOLDADO	UPPER PROTECTION WELDED	1	1	1	
	Q262030000	ARANDELA GROW. A5 A.304	WASHER GROW. A5 A.304	2	2	2	
	Q232030000	ARANDELA A5	WASHER A5	2	2	2	
	Q012032000	TORNILLO EXAGONAL M5X15	HEXAGONAL BOLT M5x15	2	2	2	
4	Z276501000	TUNEL ASPIRADOR VAHOS COMP.	COMP. STEAM EXTRACTOR TUN	1	1	-	
5	Z276206000	JUNTA SUPERIOR COMPACTO	COMPACT UPPER JOINT	1	1	-	
6	Z276208000	JUNTA LATERAL COMPACTO	COMPACT SIDE JOINT	2	2	-	
7	Z276215000	GUIA ENTRADA-SALIDA	INPUT-OUTPUT GUIDE	2	2	-	
	Q012042000	TORNILLO EXAGONAL M6X15 A304	HEXAGONAL BOLT M6x15 A304	4	4	-	
	Q262040000	ARANDELA GROW. A6 A.304	WASHER GROW. A6 A.304	4	4	-	
	Z310341000	ARANDELA RECTANGULAR	RECTANGULAR WASHER	4	4	-	
	Q162040000	TUERCA EXAGONAL M6	HEXAGONAL NUT M6	4	4	-	
8	Z275075000	DESLIZAMIENTO GUIAS	GUIDE SLIDE	2	2	-	
	Q232040000	ARANDELA A6	WASHER A6	4	4	-	
	Q222012000	TUERCA AUTOBLOCANTE M6	SELF-LOCKING NUT M6	4	4	-	
9	Z276207000	JUNTA INFERIOR COMPACTO	COMPACT LOWER GUIDE	1	1	-	
10	Z276221000	SOPORTE UÑA ENTRADA	INPUT CLAW SUPPORT	1	1	-	
	Q012042000	TORNILLO EXAGONAL M6X15 A304	HEXAGONAL BOLT M6x15 A304	2	2	-	
	Q232050000	ARANDELA A8	WASHER A8	4	4	-	
	Q232040000	ARANDELA A6	WASHER A6	2	2	-	
	Q222012000	TUERCA AUTOBLOCANTE M6	SELF-LOCKING NUT M6	2	2	-	
11	Z275077000	UÑA ARRASTRE IZQUIERDA LASER	LASER LEFT DRAG CLAW	1	1	-	

<b>MOD.</b>	<b>LAVAVAJILLAS COMPACTOS COMPACT DISHWASHERS</b>	<b>ZONA</b>	<b>TUNEL ASPIRADOR DE VAHOS STEAM INTAKE TUNNEL</b>
-------------	---	-------------	---

vsezip.ru

+7(812)987-08-81

ITEM	CODIGO	DENOMINACION	TEXTO	FI-160 ECO-160	FI-200 ECO-200	FI-200 W		
12	Z275078000	UÑA ARRASTRE DERECHA LASER	LASER RIGHT DRAG CLAW	1	1	-		
	Q232050000	ARANDELA A8	WASHER A8	4	4	-		
	Q152046000	TORNILLO EXAGON. CON CUELLO	HEXAGONAL BOLT. WITH NECK	2	2	-		
	Q232040000	ARANDELA A6	WASHER A6	2	2	-		
	Q222012000	TUERCA AUTOBLOCANTE M6	SELF-LOCKING NUT M6	2	2	-		
13	Z276293000	TUNEL ASPIRAD. VAHOS W COMP.	COMP. W STEAM EXTRAC.TUNN	-	-	1		

Зип Общепит

vsezip.ru

+7(812)987-08-81

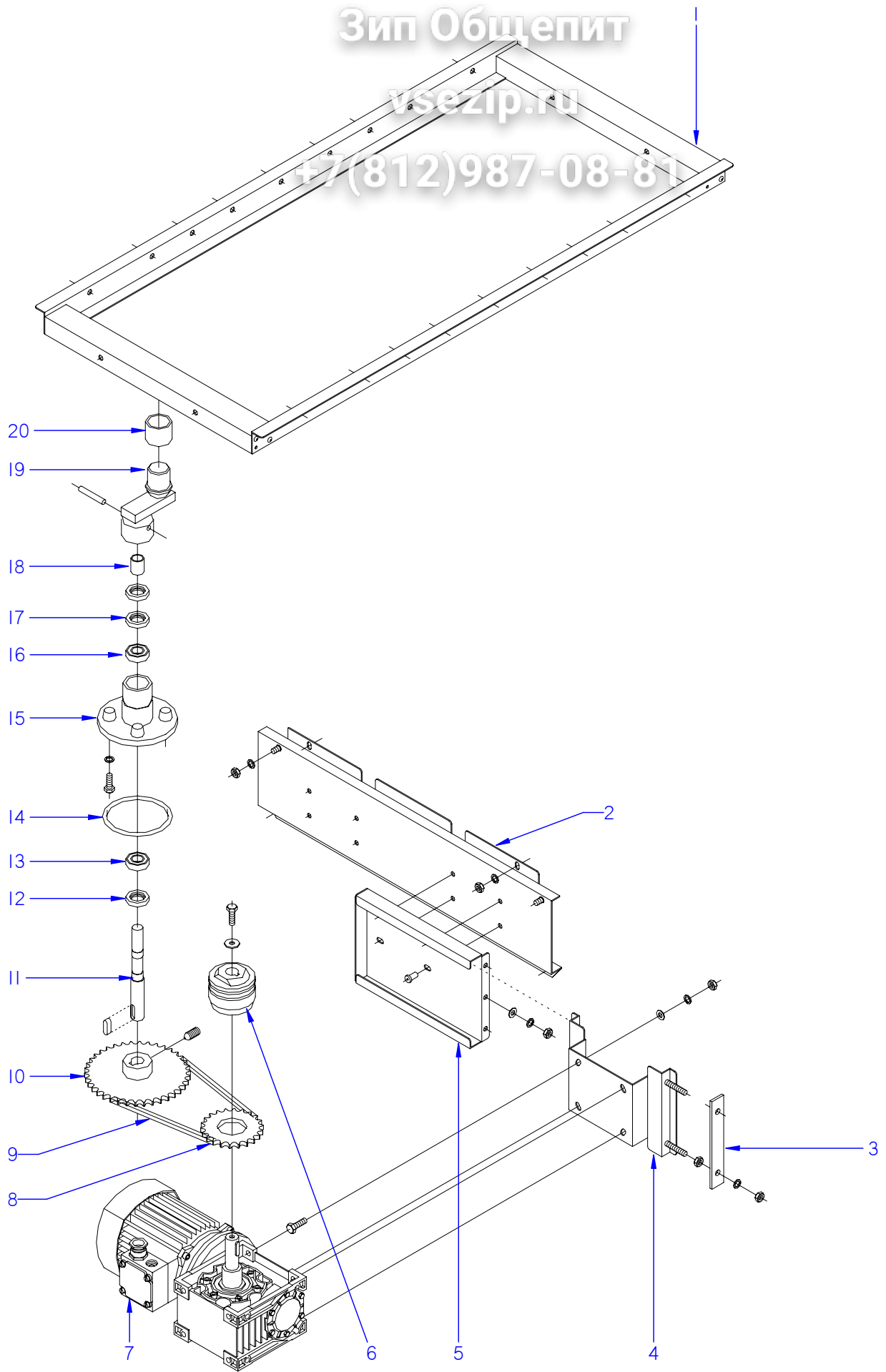

ITEM MARCADO EN COLOR = REPUESTO RECOMENDADO  
COLOURED ITEM = RECOMMENDED SPARE PART

N plano	Firma	Fecha	Aparato	SISTEMA DE ARRASTRE	Lamina	Fagor Industrial S.Coop. <b>FAGOR</b>
C-2123	<i>(Signature)</i>	2008-10	LAVAVAJILLAS COMPACTOS		4	Oñate

MOD.	LAVAVAJILLAS COMPACTOS COMPACT DISHWASHERS	ZONA	SISTEMA DE ARRASTRE / SWEEP ZON
------	---	------	---------------------------------

ITEM	CODIGO	DENOMINACION	TEXTO	FI-160 ECO-160	FI-200 ECO-200	FI-200 W		
1	Z275051000	SOPORTE UÑAS DE LAVADO	WASH CLAW SUPPORT	1	1	1		
2	Z270113000	SOPORTE TRANSVERSAL	TRANSVERSAL SUPPORT	1	1	1		
	Q262040000	ARANDELA GROW. A6 A.304	WASHER GROW. A6 A.304	4	4	4		
	Q162040000	TUERCA EXAGONAL M6	HEXAGONAL NUT M6	4	4	4		
	Q221343000	REMACHE EXAGONAL M6	HEXAGONAL RIVET M6	11	11	11		
3	Z275006000	TENSOR	TENSIONER	1	1	1		
	Q162050000	TUERCA EXAGONAL M8x1 INOX.	HEXAGONAL NUT M8x1 INOX.	3	3	3		
	Q262050000	ARANDELA GROW. A8 A.304	WASHER GROW. A8 A.304	3	3	3		
4	Z275002000	SOPORTE MOTORREDUCTOR	GEARED MOTOR SUPPORT	1	1	1		
	Q012053000	TORNILLO EXAGONAL M8X20	HEXAGONAL BOLT M8x20	4	4	4		
	Q262050000	ARANDELA GROW. A8 A.304	WASHER GROW. A8 A.304	4	4	4		
	Q162050000	TUERCA EXAGONAL M8x1 INOX.	HEXAGONAL NUT M8x1 INOX.	4	4	4		
5	Z275005000	GUIA MOTORREDUCTOR	GEARED MOTOR GUIDE	1	1	1		
	Q152018000	PERNO SOLDADO M6X10	WELDED BOLT M6X10	2	2	2		
	Q262040000	ARANDELA GROW. A6 A.304	WASHER GROW. A6 A.304	3	3	3		
	Q162040000	TUERCA EXAGONAL M6	HEXAGONAL NUT M6	3	3	3		
6	Z105008000	LIMITADOR DE PAR LS 70	TORQUE LIMITER LS 70	1	1	1		
7	Z275073000	MOTORREDUCTOR SIN-FIN MONTA	WORM GEAR MOTOR MOUNTED	1	-	-		
7	Z295003000	MOTORREDUCTOR SIN-FIN MONTA	WORM GEAR MOTOR MOUNTED	-	1	1		
8	Z105009000	CORONA	CROWN	1	1	-		
8	Z104104000	CORONA 60 Hz,	CROWN 60 Hz,	1	1	1		
9	Z275008000	CADENA IRIS 12.7X7.95X730	IRIS CHAIN 12.7x7.95x730	1	1	1		
	Z105012000	ENGANCHE CADENA SIMPLE	SIMPLE CHAIN FASTENER	1	1	1		
10	Z275007000	PIÑON	PINION	1	-	1		
10	Z105013000	PIÑON	PINION	-	1	-		
	Z105051000	VARILLA ROSCADA M. 8X16	THREADED ROD M-8x16	1	1	1		
11	Z275011000	EJE	SHAFT	1	1	1		
	Z105014000	CHAVETA 25X6X6	COTTER PIN 25X6X6	1	1	1		
12	Z105016000	RETEN RADIAL 20x35x7	RADIAL SEAL 20x35x7	1	1	1		
13	Z105017000	RODAMIENTO 6003-2RS	BEARING 6003 - 2RS	1	1	1		
14	Q307045000	JUNTA TORICA 105.28x94.62	"O" RING 105.28x94.62	1	1	1		

MOD.

LAVAVAJILLAS COMPACTOS  
COMPACT DISHWASHERS

ZONA

SISTEMA DE ARRASTRE / SWEEP ZON

ITEM	CODIGO	DENOMINACION	TEXTO	+7(812)987-08-81				
				FI-160 ECO-160	FI-200 ECO-200	FI-200 W		
15	Z275021000	SOPORTE RODAMIENTOS	BEARING SUPPORT	1	1	1		
	Q012053000	TORNILLO EXAGONAL M8X20	HEXAGONAL BOLT M8x20	4	4	4		
	Q262050000	ARANDELA GROW. A8 A.304	WASHER GROW. A8 A.304	4	4	4		
16	Z105017000	RODAMIENTO 6003-2RS	BEARING 6003 - 2RS	1	1	1		
17	Z105016000	RETEN RADIAL 20x35x7	RADIAL SEAL 20x35x7	2	2	2		
18	Z105055000	CASQUILLO DISTANCIADOR	SPACER BUSHING	1	1	1		
19	Z275025000	BULON ARRASTRE	DRIVE BOLT	1	1	1		
	Q362000000	PASADOR INOX.6,3x50	PIN INOX.6.3x50	1	1	1		
20	Z105027000	CASQUILLO	BUSHING	1	1	1		

Зип Общепит

vsezip.ru

+7(812)987-08-81

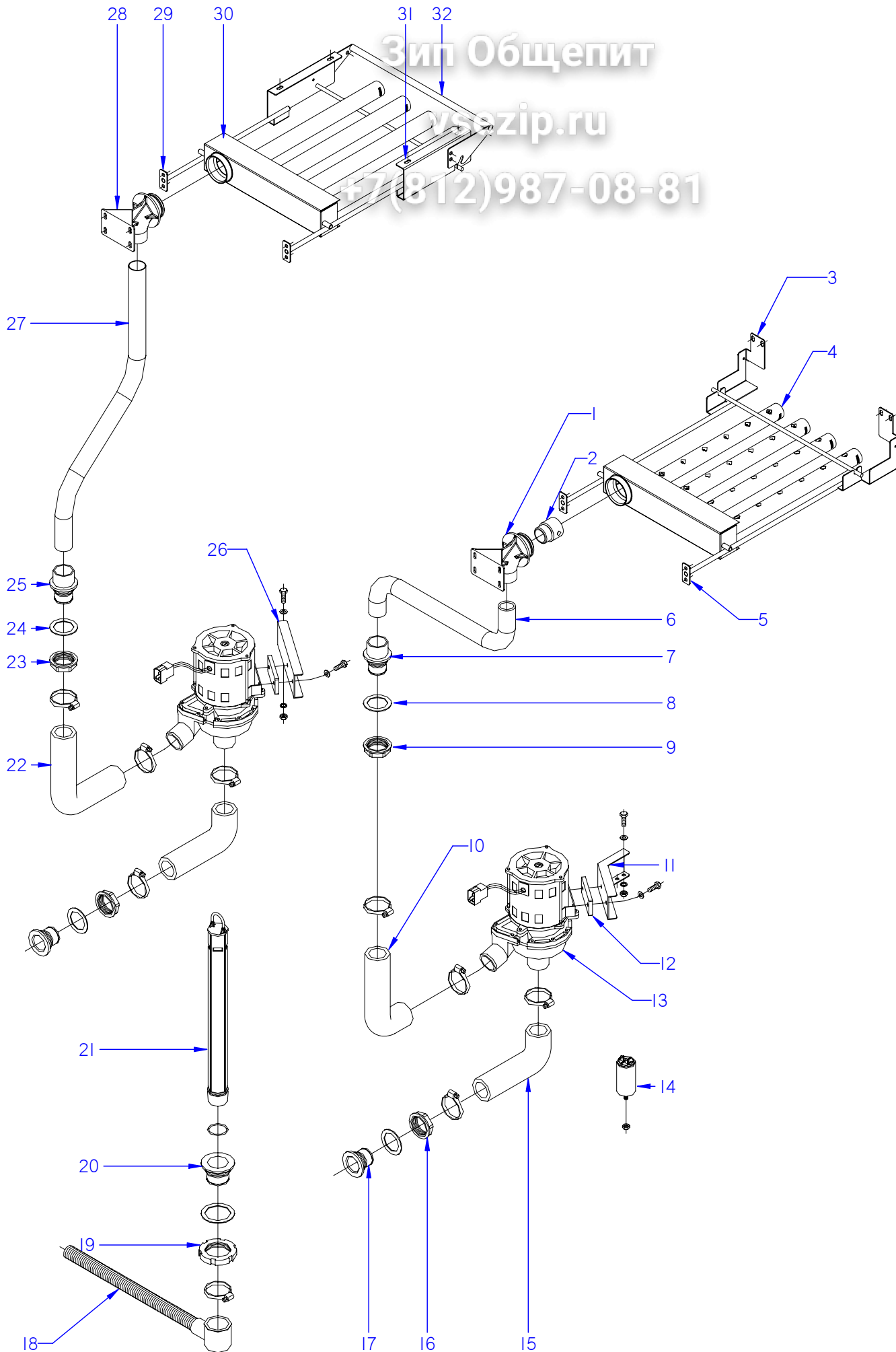

ITEM MARCADO EN COLOR = REPUESTO RECOMENDADO  
COLOURED ITEM = RECOMMENDED SPARE PART

N plano	Firma	Fecha	Aparato	SISTEMA DE LAVADO	Lamina	Fagor Industrial S.Coop. <b>FAGOR</b>
C-2124	<i>[Signature]</i>	2008-10	LAVAVAJILLAS COMPACTOS		5	Oñate



<b>MOD.</b>	<b>LAVAVAJILLAS COMPACTOS COMPACT DISHWASHERS</b>	<b>ZONA</b>	<b>SISTEMA DE LAVADO / WASHING SYSTEM</b>
-------------	---	-------------	---

ITEM	CODIGO	DENOMINACION	TEXTO	FI-160 ECO-160	FI-200 ECO-200	FI-200 W		
1	Z330789000	PASAMUROS SUPER. PRELAVADO	PREWASH UPPER BUSHING.	1	1	1		
	Q262040000	ARANDELA GROW. A6 A.304	WASHER GROW. A6 A.304	4	4	4		
	Q232040000	ARANDELA A6	WASHER A6	4	4	4		
	Q162040000	TUERCA EXAGONAL M6	HEXAGONAL NUT M6	4	4	4		
2	Z330787000	REDUCCION PRELAVADO	PREWASH REDUCTION	1	1	1		
3	Z370711000	SOPORTE INFERIOR DERECHO	RIGHT LOWER SUPPORT	1	1	1		
	Q262040000	ARANDELA GROW. A6 A.304	WASHER GROW. A6 A.304	4	4	4		
	Q232040000	ARANDELA A6	WASHER A6	4	4	4		
	Q162040000	TUERCA EXAGONAL M6	HEXAGONAL NUT M6	4	4	4		
4	Z270761000	DISTRIBUIDOR COMPACTO DCHO.	RIGHT COMPACT DISTRIBUTOR	1	1	1		
	Z270721000	TAPON CIERRE	CLOSING PLUG	4	4	4		
	Q307062000	JUNTA TORICA 23.47X28.71X2.62	O-RING 23.47X28.71X2.62	4	4	4		
5	Z370715000	SOPORTE INFERIOR IZQUIERDO	LEFT LOWER SUPPORT	1	1	1		
	Q262040000	ARANDELA GROW. A6 A.304	WASHER GROW. A6 A.304	4	4	4		
	Q232040000	ARANDELA A6	WASHER A6	4	4	4		
	Q162040000	TUERCA EXAGONAL M6	HEXAGONAL NUT M6	4	4	4		
6	Z330774000	CONDUC. INF. DCHA. PRELAVADO	PREWASH RIGHT LOW. PIPE	1	1	1		
7	Z330751000	PASAMUROS IMPULSION PRELAV.	PREWASH IMPULSE BUSHING	1	1	1		
7	Z330790000	PASAMUROS IMPULSION PRELAV.	PREWASH IMPULSE BUSHING	1	1	1		
8	Q307058000	ARANDELA Ø60x44X2	WASHER Ø60x44X2	1	1	1		
9	Z710708000	TUERCA PASAMUROS	WALL BUSHING NUT	1	1	1		
	Q307065000	JUNTA TORICA Ø43,01X37,77X2.62	O-RING Ø43.01X37.77X2.62	1	1	1		
10	Z710905000	CONDUCTO IMPULSION ANTER.	FRONT IMPULSE PIPE	1	1	1		
	Q881307000	ABRAZADERA 40-60	CLAMP 40-60	2	2	2		
11	Z711001000	SOPORTE MOTOBOMBA ANTER.	FRONT MOTOR PUMP SUPPORT	1	1	1		
12	Z201003000	BASE BOMBA LAVADO 1003016	WASH PUMP BASE 1003016	2	2	2		
	Q232040000	ARANDELA A6	WASHER A6	4	4	4		
	Q012042000	TORNILLO EXAGONAL M6X15	HEXAGONAL BOLT M6x15	4	4	4		
13	Z201011000	BOMBA DE LAVADO	WASH PUMP	2	2	—		
13	Z203511000	BOMBA DE LAVADO 60 Hz.	WASH PUMP 60 Hz.	2	2	2		

MOD.	LAVAVAJILLAS COMPACTOS COMPACT DISHWASHERS	ZONA	SISTEMA DE LAVADO / WASHING SYSTEM
------	---	------	------------------------------------

ITEM	CODIGO	DENOMINACION	TEXTO	FI-160 ECO-160	FI-200 ECO-200	FI-200 W		
14	V321300000	CONDENSADOR 10 M.F.	CONDENSER 10 M.F.	2	2	2		
	Q162050000	TUERCA EXAGONAL M8x1 INOX.	HEXAGONAL NUT M8x1 INOX.	2	2	2		
15	Z710904000	CONDUCTO ASPIRACION	EXTRACTOR PIPE	2	2	2		
	Q881307000	ABRAZADERA 40-60	CLAMP 40-60	2	2	2		
16	Z710708000	TUERCA PASAMUROS	WALL BUSHING NUT	2	2	2		
17	Z710903000	PASAMUROS ASPIRACION	EXTRACTOR BUSHING	2	2	2		
	Q307058000	ARANDELA Ø60x44X2	WASHER Ø60x44X2	2	2	2		
18	Z200910000	MANGUERA DESAGUE	DRAINAGE HOSE	1	1	1		
	Q881307000	ABRAZADERA 40-60	CLAMP 40-60	1	1	1		
19	Q220001000	TUERCA RANURADA M56X2,5 HOS	GROOVED NUT M56X2.5 HOS	1	1	1		
20	Z710902000	PASAMUROS DESAGUE	DRAINAGE BUSHING	1	1	1		
	Q307059000	JUNTA Ø72x56x2	JOINT Ø72x56x2	1	1	1		
21	Z270901000	ALIVIADERO	OVERFLOW	1	1	1		
	Q307051000	JUNTA TORICA Ø36.17X41.41X2.6	O-RING Ø36.17X41.41X2.6	1	1	1		
22	Z710906000	CONDUCTO IMPULSION POSTER.	REAR IMPULSE PIPE	1	1	1		
	Q881307000	ABRAZADERA 40-60	CLAMP 40-60	2	2	2		
23	Z710708000	TUERCA PASAMUROS	WALL BUSHING NUT	1	1	1		
	Q307065000	JUNTA TORICA Ø43,01X37,77X2.62	O-RING Ø43.01X37.77X2.62	1	1	1		
24	Q307058000	ARANDELA Ø60x44X2	WASHER Ø60x44X2	1	1	1		
25	Z330751000	PASAMUROS IMPULSION PRELAV.	PREWASH IMPULSE BUSHING	1	1	1		
25	Z330790000	PASAMUROS IMPULSION PRELAV.	PREWASH IMPULSE BUSHING	1	1	1		
26	Z711002000	SOPORTE MOTOBOMBA POSTER.	REAR MOTOR PUMP SUPPORT	1	1	1		
	Q012042000	TORNILLO EXAGONAL M6X15	HEXAGONAL BOLT M6x15	4	4	4		
	Q232040000	ARANDELA A6	WASHER A6	4	4	4		
	Q262040000	ARANDELA GROW. A6 A.304	WASHER GROW. A6 A.304	4	4	4		
	Q162040000	TUERCA EXAGONAL M6	HEXAGONAL NUT M6	4	4	4		
27	Z330776000	CONDUC. SUP. DCHA PRELAVADO	PREWASH RIGHT UPPER PIPE	1	1	1		
28	Z330789000	PASAMUROS SUPER. PRELAVADO	PREWASH UPPER BUSHING.	1	1	1		
	Q262040000	ARANDELA GROW. A6 A.304	WASHER GROW. A6 A.304	4	4	4		
	Q232040000	ARANDELA A6	WASHER A6	4	4	4		
	Q162040000	TUERCA EXAGONAL M6	HEXAGONAL NUT M6	4	4	4		

MOD. <b>LAVAVAJILLAS COMPACTOS COMPACT DISHWASHERS</b>							ZONA	<b>SISTEMA DE LAVADO / WASHING SYSTEM</b>				
ITEM	CODIGO	DENOMINACION	TEXTO	FI-160 ECO-160	FI-200 ECO-200	FI-200 W						
29	Z370701000	SOPORTE SUPERIOR DERECHO	RIGHT UPPER SUPPORT	1	1	1						
	Q262040000	ARANDELA GROW. A6 A.304	WASHER GROW. A6 A.304	4	4	4						
	Q232040000	ARANDELA A6	WASHER A6	4	4	4						
	Q162040000	TUERCA EXAGONAL M6	HEXAGONAL NUT M6	4	4	4						
30	Z270764000	DISTRIBUIDOR COMPACTO IZDO.	LEFT COMPACT DISTRIBUTOR	1	1	1						
	Z270721000	TAPON CIERRE	CLOSING PLUG	4	4	4						
	Q307062000	JUNTA TORICA 23.47X28.71X2.62	O-RING 23.47X28.71X2.62	4	4	4						
31	Z370705000	SOPORTE SUPERIOR IZQUIERDO	LEFT UPPER SUPPORT	1	1	1						
	Q262040000	ARANDELA GROW. A6 A.304	WASHER GROW. A6 A.304	4	4	4						
	Q232040000	ARANDELA A6	WASHER A6	4	4	4						
	Q162040000	TUERCA EXAGONAL M6	HEXAGONAL NUT M6	4	4	4						
32	Z370725000	SUJECION DISTRIB. PRELAVADO	PREWASH DISTRIB. FASTENING	1	1	1						
	Q152047000	TORNILLO CILINDRI. CON CUELLO	CYLINDRICAL SCREW WITH NEC	2	2	2						
	Q262030000	ARANDELA GROW. A5 A.304	WASHER GROW. A5 A.304	2	2	2						
	Q212031000	TUERCA SOMBRERETE M5	COWL NUT M5	2	2	2						

Зип Общепит

vsezip.ru

+7(812)987-08-81

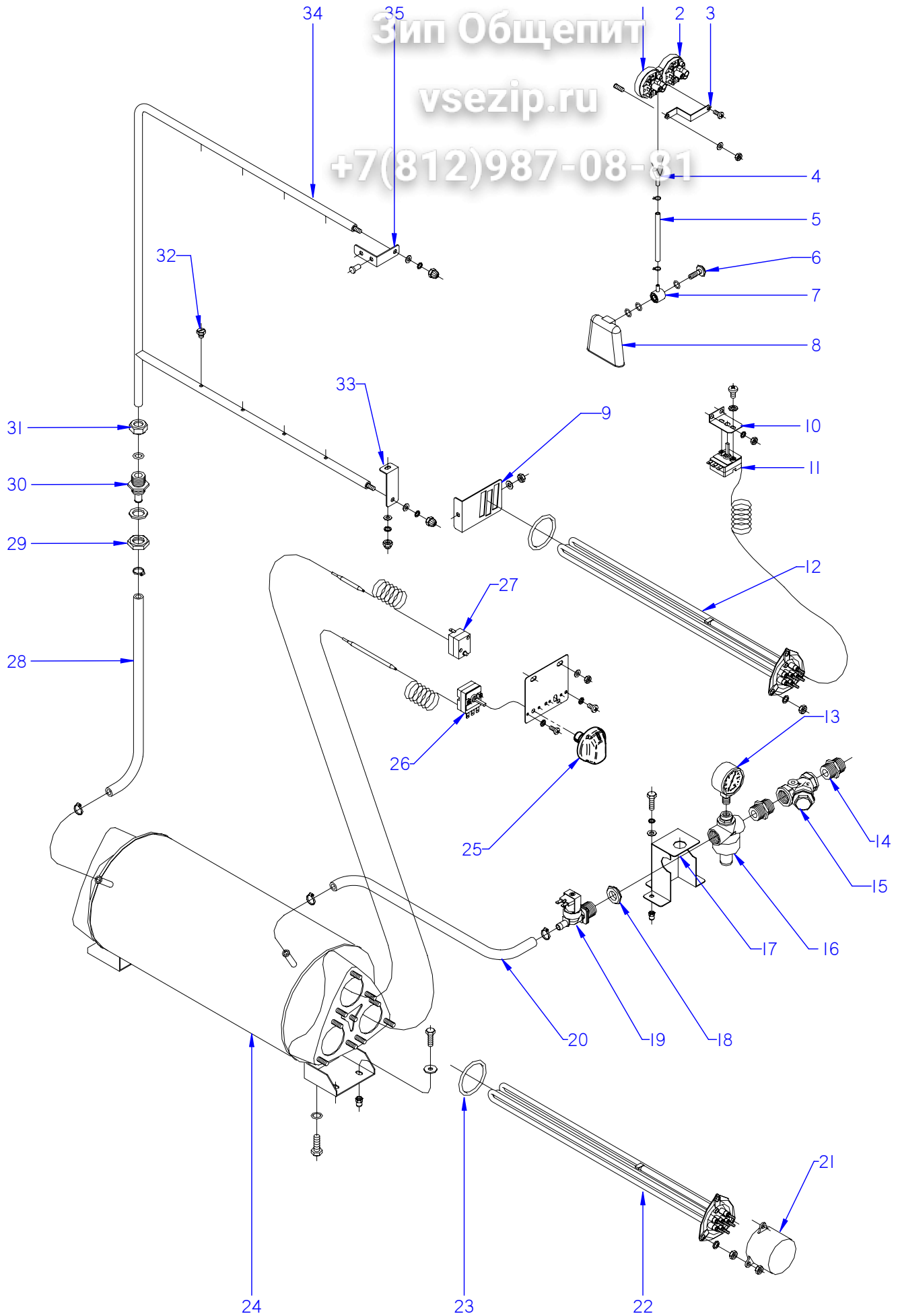

ITEM MARCADO EN COLOR = REPUESTO RECOMENDADO  
COLOURED ITEM = RECOMMENDED SPARE PART

N plano	Firma	Fecha	Aparato	SISTEMA DE ACLARADO	Lamina	Fagor Industrial S.Coop. <b>FAGOR</b>
C-2125	<i>[Signature]</i>	2008-10	LAVAVAJILLAS COMPACTOS FI / W		6	Oñate

MOD.	LAVAVAJILLAS COMPACTOS COMPACT DISHWASHERS	ZONA	SISTEMA DE ACLARADO / RINSE SYSTEM
------	---	------	------------------------------------

ITEM	CODIGO	DENOMINACION	TEXTO	FI-160	FI-200	FI-200 W		
1	Z403021000	PRESOSTATO SIMPLE	SIMPLE PRESSURE SWITCH	1	1	1		
2	Z273006000	PRESOSTATO SIMPLE	SIMPLE PRESSURE SWITCH	1	1	1		
3	Z602923000	SOPORTE PRESOSTATO	PRESSURE SWITCH SUPPORT	1	1	1		
	Q082032000	TORNILLO ALOMADO BZ-3,5X9,5	CURVED SCREW BZ-3.5x9.5	1	1	1		
	Q232040000	ARANDELA A6	WASHER A6	1	1	1		
	Q162040000	TUERCA EXAGONAL M6	HEXAGONAL NUT M6	1	1	1		
4	Z103077000	RACORD EN Y	Y-CONNECTION	1	1	1		
5	3702400000	TUBO GOMA NEGRO D 8*4	BLACK RUBBER PIPE Ø 8*4	1	1	1		
	P102154000	BRIDA ELASTICA TUBO	ELASTIC PIPE FLANGE	2	2	2		
6	Z203013000	TORNILLO PRESOSTATO	PRESSURE SWITCH BOLT	1	1	1		
	Q307003000	JUNTA TORICA 16.01X10.77X2.62	O-RING 16.01X10.77X2.62	3	3	3		
7	Z203012000	EMPALME PRESOSTATO	PRESSURE SWITCH CONNEX	1	1	1		
8	Z203011000	CAMARA PRESOSTATO	PRESSURE SWITCH	1	1	1		
9	Z273602000	SUJECION RESISTENCIA	RESISTOR FASTENING	1	1	1		
	Q232040000	ARANDELA A6	WASHER A6	1	1	1		
	Q162040000	TUERCA EXAGONAL M6	HEXAGONAL NUT M6	1	1	1		
	Q307044000	JUNTA TORICA Ø 67.18x56.52x5.3	O-RING Ø 67.18x56.52x5.3	1	1	1		
10	Z850111000	SOPORTE TERMOSTATO	THERMOSTAT SUPPORT	1	1	1		
	Q232040000	ARANDELA A6	WASHER A6	2	2	2		
	Q162040000	TUERCA EXAGONAL M6	HEXAGONAL NUT M6	2	2	2		
	Q152024000	TORNILLO AVELLANADO M4X8 A304	COUNTERSUNK BOLT M4X8 A304	2	2	2		
11	Z203014000	TERMOSTATO CALDERIN	WASH DRUM THERMOSTAT	2	2	2		
S/Nº	Z273072000	REGULACION TERMOSTATO 63°C	THERMOSTAT CONTROL 63°C	1	1	1		
12	Z121741000	RESISTENCIA COMP.230V.	COMP. RESISTOR 230V.	1	1	—		
12	Z271705000	RESISTENCIA W ARRASTRE	DRIVE RESISTOR W	—	—	1		
	Q262040000	ARANDELA GROW. A6 A.304	WASHER GROW. A6 A.304	3	3	3		
	Q162040000	TUERCA EXAGONAL M6	HEXAGONAL NUT M6	3	3	3		
13	Z102316000	MANOMETRO	MANOMETER	1	1	—		
14	Z102301000	MANGUITO 3/4"	HOSE 3/4"	2	2	—		
15	Z102308000	FILTRO 3/4	FILTER 3/4"	1	1	—		
16	Z102307000	REDUCTOR PRESION	PRESSURE REDUCER	1	1	—		

<b>MOD.</b>	<b>LAVAVAJILLAS COMPACTOS COMPACT DISHWASHERS</b>	<b>ZONA</b>	<b>SISTEMA DE ACLARADO / RINSE SYSTEM</b>
-------------	---	-------------	---

ITEM	CODIGO	DENOMINACION	TEXTO	FI-160	FI-200	FI-200 W		
17	Z271120000	SOPORTE CONDUCCION 3/4	PIPE SUPPORT 3/4	1	1	1		
	Q012042000	TORNILLO EXAGONAL M6X15	HEXAGONAL BOLT M6x15	2	2	2		
	Q262040000	ARANDELA GROW. A6 A.304	WASHER GROW. A6 A.304	2	2	2		
18	Q221324000	TUERCA 3/4 GAS	NUT 3/4 GAS	1	1	1		
19	Z701135000	ELECTROVALVULA SIMP.220V	SOLENOID VALVE SIMP.220V	1	1	1		
20	3676900000	TUBO GOMA NEGRA Ø 17*10	BLACK RUBBER PIPE 17*10	1	1	1		
	Q881302000	ABRAZADERA 12-20	CLAMP 12-20	2	2	2		
21	Z101723000	CAPERUZA RESISTENCIA	RESISTOR HOOD	3	3	3		
	Q012042000	TORNILLO EXAGONAL M6X15	HEXAGONAL BOLT M6x15	4	4	4		
	Q301304000	ARANDELA PLANA 23X6,5X2	FLAT WASHER 23X6.5X2	4	4	4		
	Q012063000	TORNILLO EXAGONAL M10X20	HEXAGONAL SCREW M10X20	1	1	1		
22	Z121741000	RESISTENCIA COMP.230V.	COMP. RESISTOR 230V.	3	3	3		
22	Z271705000	RESISTENCIA W ARRASTRE	DRIVE RESISTOR W	-	-	3		
	Q221305000	TUERCA EXAG.AUTOBL. M4 ZINC.	HEX BOLT SELF-LOCK M4 ZINC	18	18	18		
23	Q307044000	JUNTA TORICA Ø 67,18x56,52x5,3	O-RING Ø 67.18x56.52x5.3	3	3	3		
24	Z311701000	CALDERIN	BOILER	1	1	1		
	Q163140000	TUERCA EXAGONAL M6 LATON	HEXAGONAL NUT M6 BRASS	18	18	18		
25	Z203069000	BOTON DE MANDO	CONTROL BUTTON	1	1	1		
S/Nº	Z273037000	SOPORTE TERMOST. A.C.	THERMOSTAT SUPPORT A.C.	2	2	2		
	Q232040000	ARANDELA A6	WASHER A6	6	6	6		
	Q162040000	TUERCA EXAGONAL M6	HEXAGONAL NUT M6	6	6	6		
	Q152024000	TORNILLO AVELLANADO M4X8 A304	COUNTERSUNK BOLT M4X8 A304	4	4	4		
26	Z203014000	TERMOSTATO CALDERIN	WASH DRUM THERMOSTAT	1	1	1		
S/Nº	Z273073000	REGULACION TERMOSTATO 70°C	THERMOSTAT CONTROL 70°C	1	1	1		
27	Z276365000	TERMOSTATO 150°C	THERMOSTAT 150°C	1	1	1		
28	3676900000	TUBO GOMA NEGRA Ø 17*10	BLACK RUBBER PIPE 17*10	1	1	1		
	Q881302000	ABRAZADERA 12-20	CLAMP 12-20	2	2	2		
29	Q223023000	TUERCA EXAGONAL 5-8 LATON	HEX NUT 5-8 BRASS	1	1	1		
30	Z271901000	PASAMUROS ACLARADO	RINSE BUSHING	1	1	1		
	Q307032000	JUNTA Ø32X21X3	JOINT Ø32X21X3	1	1	1		
31	Q223108000	TUERCA M.24X2.5	NUT M.24X2.5	1	1	1		

ITEM	CODIGO	DENOMINACION	TEXTO	FI-160	FI-200	FI-200 W		
32	Z211903000	TOBERA ACLARADO	RINSE NOZZLE	8	8	8		
33	Z271912000	AMARRE INFERIOR ACLARADO	LOWER RINSE FASTENING	1	1	1		
	Q262030000	ARANDELA GROW. A5 A.304	WASHER GROW. A5 A.304	1	1	1		
	Q232040000	ARANDELA A6	WASHER A6	3	3	3		
	Q212031000	TUERCA SOMBRERETE M5	COWL NUT M5	1	1	1		
34	Z271902000	12Z2719020 ARBOL DE ACLARADO	12Z2719020 RINSE SHAFT	1	1	1		
	Q307063000	JUNTA TORICA 12,29X19,35X3,53	O-RING 12.29X19.35X3.53	1	1	1		
35	Z271911000	SOPORTE SUPERIOR ACLARADO	UPPER RINSE SUPPORT	1	1	1		
	Q412004000	REMACHE MONOBOLT Ø4.8	MONOBOLT RIVET Ø4.8	2	2	2		
	Q262030000	ARANDELA GROW. A5 A.304	WASHER GROW. A5 A.304	1	1	1		
	Q232040000	ARANDELA A6	WASHER A6	1	1	1		
	Q212031000	TUERCA SOMBRERETE M5	COWL NUT M5	1	1	1		

Зип Общелит

vsezip.ru

+7(812)967-08-81

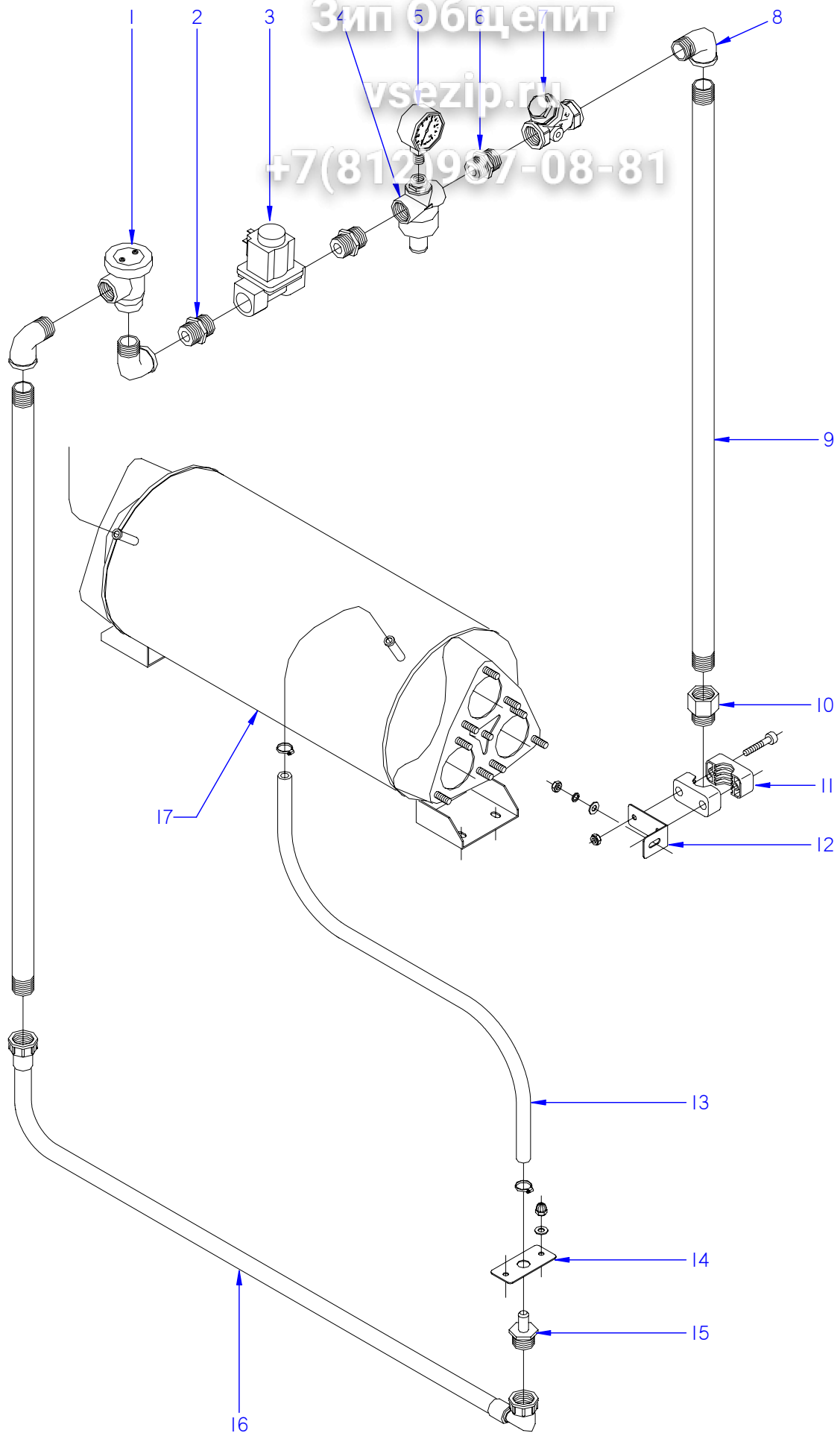

ITEM MARCADO EN COLOR = REPUESTO RECOMENDADO  
COLOURED ITEM = RECOMMENDED SPARE PART

N plano	Firma	Fecha	Aparato	ENTRADA DE AGUA	Lamina	Fagor Industrial S.Coop. <b>FAGOR</b>
C-2126	<i>[Signature]</i>	2008-10	LAVAVAJILLAS COMPACTOS W		7	Oñate



MOD.		LAVAVAJILLAS COMPACTOS COMPACT DISHWASHERS	ZONA	ENTRADA DE AGUA / WATER INLET			
ITEM	CODIGO	DENOMINACION	TEXTO	FI-200 W			
1	Z718418000	VALVULA ANTIRRETORNO W	NON-RETURN VALVE W	1			
2	Z718453000	MANGUITO 3/4"GAS-NPT	HOSE 3/4" GAS-NPT	2			
3	Z718415000	ELECTROVALVULA USA	SOLENOID VALVE USA	1			
4	Z102307000	REDUCTOR PRESION	PRESSURE REDUCER	1			
5	Z271125000	MANOMETRO W NSF	MANOMETER W NSF	1			
6	Z102301000	MANGUITO 3/4"	HOSE 3/4"	1			
7	Z102308000	FILTRO 3/4	FILTER 3/4"	1			
8	Z718421000	CODO M-H 3/4" LATON	L-BEND M-H 3/4" BRASS	2			
9	Z271121000	CONDUCCION ANTIRRETORNO W	NON-RETURN PIPE W	2			
10	T125033000	ADAPTADOR ROSCA 3/4"-3/4NPT	THREAD ADAPTER 3/4"-3/4NPT	1			
11	Z718413000	BRIDA ADA 3/4 SIN BASE-TOR	FLANGE ADA 3/4 W/O BASE-TOR	8			
	Q052046000	TORNILLO ALLEN M6X40 A.304	ALLEN BOLT M6X40 A.304	8			
	Q301370000	ARANDELA PLANA A13	FLAT WASHER A13	8			
	Q222012000	TUERCA AUTOBLOCANTE M6	SELF-LOCKING NUT M6	8			
12	Z271122000	SOPORTE ANTIRRETORNO	NON-RETURN SUPPORT	4			
	Q232040000	ARANDELA A6	WASHER A6	4			
	Q262040000	ARANDELA GROW. A6 A.304	WASHER GROW. A6 A.304	4			
	Q162040000	TUERCA EXAGONAL M6	HEXAGONAL NUT M6	4			
	Q212040000	TUERCA SOMBRERETE M6	COWL NUT M6	4			
13	3676900000	TUBO GOMA NEGRA Ø 17*10	BLACK RUBBER PIPE 17*10	1			
	Q881302000	ABRAZADERA 12-20	CLAMP 12-20	2			
14	Z271123000	SOPORTE EMPALME 3/4	CONNECTION SUPPORT 3/4"	1			
15	Z102309000	EMPALME 3-4	CONNECTION 3-4'	1			
16	Z602121000	MANGUERA ENTRADA AGUA	WATER INTAKE HOSE	1			
17	Z311701000	CALDER(1200003017)	BOILER (1200003017)	1			

Зип Общепит

vsezip.ru

+7(812)987-08-81

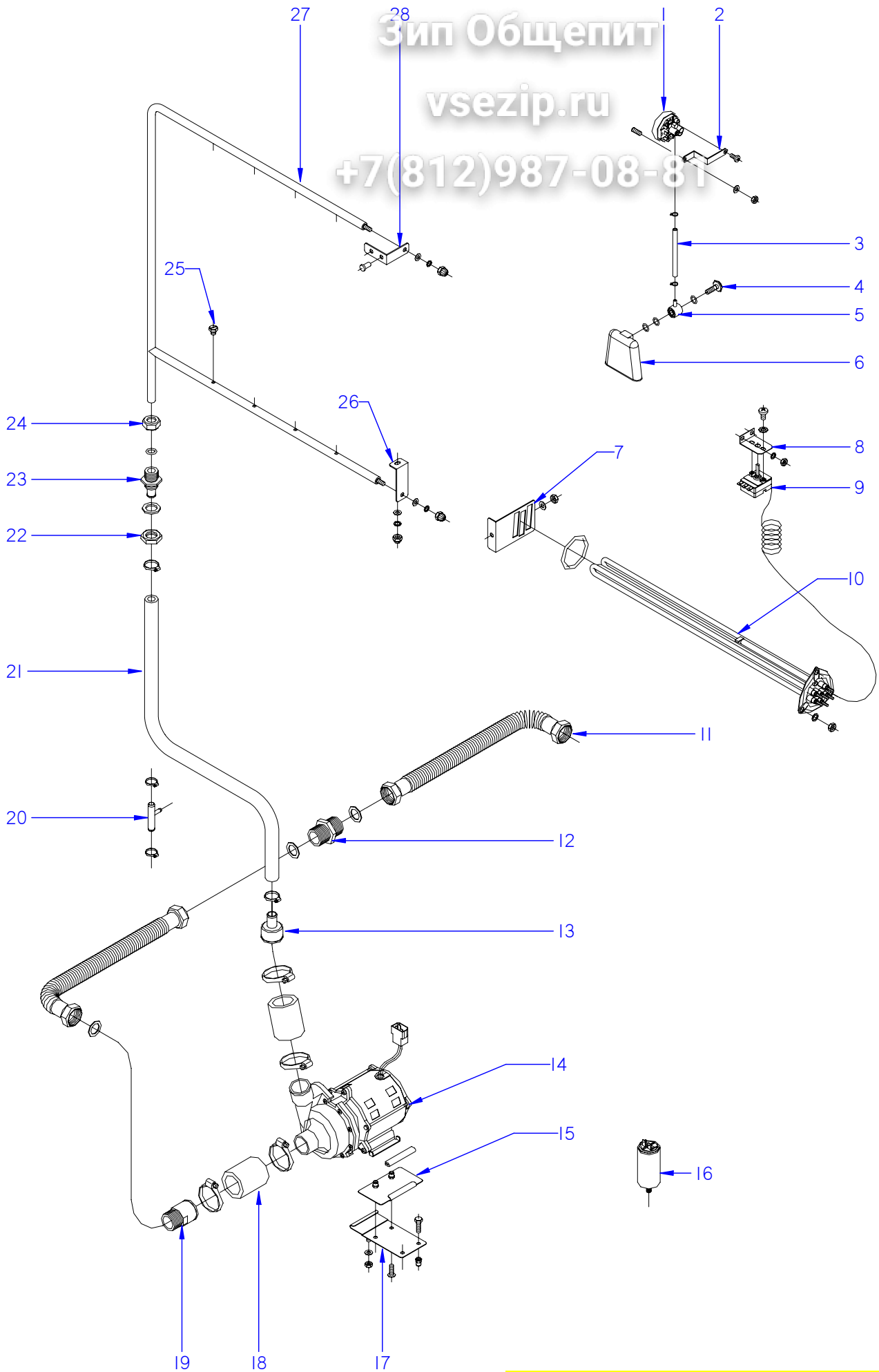

ITEM MARCADO EN COLOR = REPUESTO RECOMENDADO  
COLOURED ITEM = RECOMMENDED SPARE PART

N plano	Firma	Fecha	Aparato	SISTEMA DE ACLARADO	Lamina	Fagor Industrial S.Coop. <b>FAGOR</b>
C-2127	<i>[Signature]</i>	2008-10	LAVAVAJILLAS COMPACTOS ECO		8	Oñate

MOD.	LAVAVAJILLAS COMPACTOS COMPACT DISHWASHERS	ZONA	SISTEMA DE ACLARADO / RINSE SYSTEM
------	---	------	------------------------------------

ITEM	CODIGO	DENOMINACION	TEXTO	ECO-160	ECO-200			
1	Z273006000	PRESOSTATO SIMPLE	SIMPLE PRESSURE SWITCH	1	1			
2	Z602923000	SOPORTE PRESOSTATO	PRESSURE SWITCH SUPPORT	1	1			
	Q082032000	TORNILLO ALOMADO BZ-3,5X9,5	CURVED SCREW BZ-3.5x9.5	1	1			
	Q232040000	ARANDELA A6	WASHER A6	1	1			
	Q162040000	TUERCA EXAGONAL M6	HEXAGONAL NUT M6	1	1			
3	3702400000	TUBO GOMA NEGRO D 8*4	BLACK RUBBER PIPE Ø 8*4	1	1			
	P102154000	BRIDA ELASTICA TUBO	ELASTIC PIPE FLANGE	2	2			
4	Z203013000	TORNILLO PRESOSTATO	PRESSURE SWITCH BOLT	1	1			
	Q307003000	JUNTA TORICA 16.01X10.77X2.62	O-RING 16.01X10.77X2.62	3	3			
5	Z203012000	EMPALME PRESOSTATO	PRESSURE SWITCH CONNEX	1	1			
6	Z203011000	CAMARA PRESOSTATO	PRESSURE SWITCH	1	1			
7	Z273602000	SUJECION RESISTENCIA	RESISTOR FASTENING	1	1			
	Q232040000	ARANDELA A6	WASHER A6	1	1			
	Q162040000	TUERCA EXAGONAL M6	HEXAGONAL NUT M6	1	1			
	Q307044000	JUNTA TORICA Ø 67.18x56.52x5.3	O-RING Ø 67.18x56.52x5.3	1	1			
8	Z850111000	SOPORTE TERMOSTATO	THERMOSTAT SUPPORT	1	1			
	Q232040000	ARANDELA A6	WASHER A6	2	2			
	Q162040000	TUERCA EXAGONAL M6	HEXAGONAL NUT M6	2	2			
	Q152024000	TORNILLO AVELLANADO M4X8 A304	COUNTERSUNK BOLT M4X8 A304	2	2			
9	Z203014000	TERMOSTATO CALDERIN	WASH DRUM THERMOSTAT	2	2			
10	Z121741000	RESISTENCIA 9600 230V.	RESISTOR 9600 230V	1	1			
	Q221305000	TUERCA EX.AUTO M4 ZINCADA	EX.AUTO NUT M4 ZINC-COATED	6	6			
11	Z951101000	TUBO CORRUGADO	CORRUGATED PIPE	2	2			
12	Z162306000	MANGUITO DOBLE ROSCA LATON 1	DOUBLE HOSE BRASS THREAD	1	1			
	Q306038000	ARANDELA JUNTA Ø 31X21X1.5	JOINT WASHER Ø 31X21X1.5	3	3			
13	Z162312000	REDUCCION	REDUCTION	1	1			
14	Z401001000	BOMBA LAVADO	WASH PUMP	1	1			
	Z281112000	PROTECTOR MOTOBOMBA	MOTOR PUMP GUARD	1	1			
	3701700000	PERFIL GOMA U 9*4 (2METROS)	RUBBER PROFILE U 9*4 (2 METR	2	2			
15	Z162313000	AMARRE MOTOBOMBA COMPL.	COMPL. MOTOR PUMP FASTENI	1	1			
16	V817100000	CONDENSADOR 6 M.F.	CONDENSER 6 M.F.	1	1			

<b>MOD.</b>	<b>LAVAVAJILLAS COMPACTOS COMPACT DISHWASHERS</b>	<b>ZONA</b>	<b>SISTEMA DE ACLARADO / RINSE SYSTEM</b>
-------------	---	-------------	---

ITEM	CODIGO	DENOMINACION	TEXTO	ECO-160	ECO-200			
17	Z162315000	SOPORTE MOTOBOMBA COMPL.	COMPL. MOTOR PUMP SUPPORT	1	1			
	Q152004000	TORNILLO APLASTADO M5x13 A304	FLAT HEADED BOLT M5x13 A304	2	2			
	Q012042000	TORNILLO EXAGONAL M6X15	HEXAGONAL BOLT M6x15	2	2			
	Q162040000	TUERCA EXAGONAL M6	HEXAGONAL NUT M6	2	2			
	Q262030000	ARANDELA GROW. A5 A.304	WASHER GROW. A5 A.304	2	2			
	Q232040000	ARANDELA A6	WASHER A6	2	2			
18	Z162301000	CONDUCTO ASPIRAC. IMPULSION	EXTRACTOR PIPE. IMPULSE	2	2			
	Q881307000	ABRAZADERA 40/60	CLAMP 40/60	4	4			
19	Z701102000	MANGUITO	HOSE	1	1			
20	Z601157000	TOMA PRESION	PRESSURE INTAKE	1	1			
	Q881336000	ABRAZADERA 16/27	CLAMP 16/27	2	2			
21	3715300000	TUBO GOMA NEGRA Ø 14*24	BLACK RUBBER PIPE 14*24	1	1			
	Q881336000	ABRAZADERA 16*27	CLAMP 16*27	2	2			
22	Q223023000	TUERCA EXAGONAL 5-8 LATON	HEX NUT 5-8 BRASS	1	1			
23	Z281901000	PASAMUROS ACLARADO	RINSE BUSHING	1	1			
	Q307032000	JUNTA Ø32X21X3	JOINT Ø32X21X3	1	1			
24	Q223108000	TUERCA M.24X2.5	NUT M.24X2.5	1	1			
25	Z211903000	TOBERA ACLARADO	RINSE NOZZLE	8	8			
26	Z271912000	AMARRE INFERIOR ACLARADO	LOWER RINSE FASTENING	1	1			
	Q262030000	ARANDELA GROW. A5 A.304	WASHER GROW. A5 A.304	1	1			
	Q232040000	ARANDELA A6	WASHER A6	3	3			
	Q212031000	TUERCA SOMBRERETE M5	COWL NUT M5	1	1			
27	Z271902000	12Z2719020 ARBOL DE ACLARADO	12Z2719020 RINSE SHAFT	1	1			
	Q307063000	JUNTA TORICA 12,29X19,35X3,53	O-RING 12.29X19.35X3.53	1	1			
28	Z271911000	SOPORTE SUPERIOR ACLARADO	UPPER RINSE SUPPORT	1	1			
	Q412004000	REMACHE MONOBOLT Ø4.8	MONOBOLT RIVET Ø4.8	2	2			
	Q262030000	ARANDELA GROW. A5 A.304	WASHER GROW. A5 A.304	1	1			
	Q232040000	ARANDELA A6	WASHER A6	1	1			
	Q212031000	TUERCA SOMBRERETE M5	COWL NUT M5	1	1			

Зип Общепит

vsezip.ru

+7(812)987-08-81

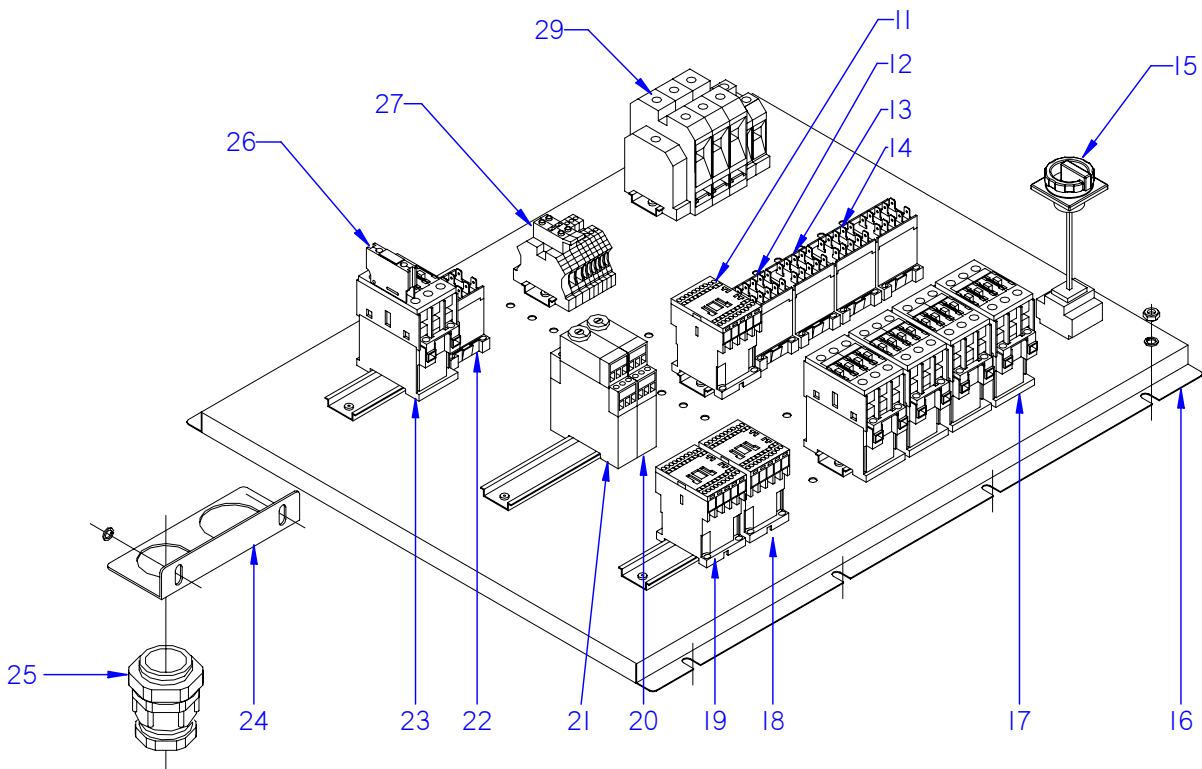
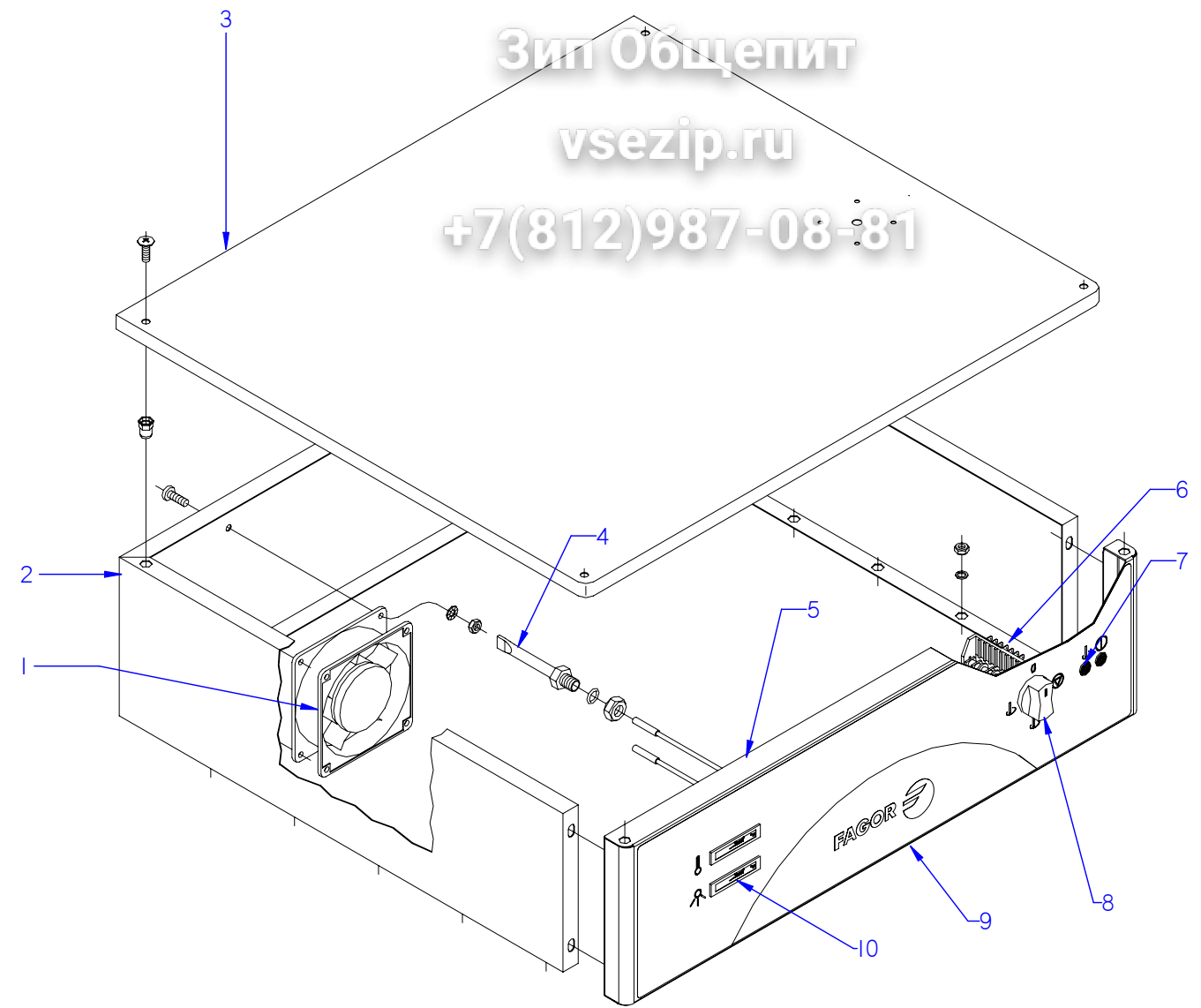

ITEM MARCADO EN COLOR = REPUESTO RECOMENDADO  
COLOURED ITEM = RECOMMENDED SPARE PART

N plano	Firma	Fecha	Aparato	CONJUNTO FUNCIONAL ELECTRICO	Lamina	Fagor Industrial S.Coop. <b>FAGOR</b>
C-2128	<i>[Signature]</i>	2008-10	LAVAVAJILLAS COMPACTOS	9	Oñate	

MOD.	LAVAVAJILLAS COMPACTOS COMPACT DISHWASHERS	ZONA	CONJUNTO FUNCIONAL ELECTRICO FUNCTIONAL ELECTRIC UNIT
------	---	------	--

ITEM	CODIGO	DENOMINACION	TEXTO	FI-160	FI-200	ECO-160	ECO-200
1	Z103066000	VENTILADOR 230V.50-60HZ	FAN 230V.50-60HZ	1	1	1	1
2	Z313043000	CUBIERTA CUADRO ELECTRICO	ELECTRIC PANEL COVER	1	1	1	1
2	Z313089000	CUBIERTA CUADRO ELECTRICO	ELECTRIC PANEL COVER	1	1	1	1
3	Z313048000	TAPA CUADRO ELECTRICO	ELECTRIC PANEL COVER	1	1	1	1
3	Z313093000	TAPA CUADRO ELECTRICO	ELECTRIC PANEL COVER	1	1	1	1
	Q152017000	TORNILLO AMARRE M6X13 A304	FASTENING BOLT M6X13 A304	4	4	4	4
4	Z263002000	VAINA INDICADOR COMPLETA	COMPLETE INDICATOR SHELL	1	1	1	1
	Q307048000	JUNTA TORICA 9,128x16,18x3,53	O-RING 9.128x16.18x3.53	1	1	1	1
	Q162070000	TUERCA EXAGONAL M12	HEXAGONAL NUT M12	1	1	1	1
5	Z313085000	FRENTE CUADRO ELECTRICO	ELECTRIC PANEL FRONT	1	1	1	1
5	Z273075000	FRENTE CUADRO ELECTRICO	ELECTRIC PANEL FRONT	1	1	1	1
	Q041324000	TORN. AVELLANADO M4X25 H.ZINC	HEXAGONAL COUNTERSUNK M4	2	2	2	2
6	Z273005000	COMMUTADOR DE FUNCIONES	FUNCTIONS SWITCH	1	1	1	1
	Z602906000	CASQUILLO	BUSHING	2	2	2	2
7	Z313080000	PILOTO AMBAR Ø18	AMBAR PILOT LIGHT Ø18	2	2	2	2
8	Z203069000	BOTON DE MANDO	CONTROL BUTTON	1	1	1	1
8	Z513024000	BOTON DE MANDO	CONTROL BUTTON	1	1	1	1
9	Z273064000	EMBELLECEDOR ADHESIVO FI-160	ADHESIVE TRIM FI-160	1	-	-	-
9	Z273077000	EMBELLECEDOR ADHESIVO FI-160	ADHESIVE TRIM FI-160	1	-	-	-
9	Z313078000	EMBELLECEDOR ADHESIVO FI-200	ADHESIVE TRIM FI-200	-	1	-	-
9	Z313079000	EMBELLECEDOR ADHESIVO FI-200	ADHESIVE TRIM FI-200	-	1	-	-
9	Z283023000	EMBELLECEDOR ADHES. ECO-160	ADHES. TRIM ECO-160	-	-	1	-
9	Z283026000	EMBELLECEDOR ADHES. ECO-160	ADHES. TRIM ECO-160	-	-	1	-
9	Z323021000	EMBELLECEDOR ADHES. ECO-200	ADHES. TRIM ECO-200	-	-	-	1
9	Z323022000	EMBELLECEDOR ADHES. ECO-200	ADHES. TRIM ECO-200	-	-	-	1
10	Z203072000	INDICADOR ANALOGICO RECT.	RECT. ANALOGUE DISPLAY	2	2	1	1
10	Z513023000	INDICADOR ANALOGICO	RECT. ANALOGUE DISPLAY	2	2	1	1
11	Z743009000	CONTACTOR SIRIUS 3RT10 16-2AP	SIRIUS 3RT10 16-2AP CONTACTOR	1	1	-	1
12	Z213007000	CONTACTOR (BOMBA LAVADO)	CONTACTOR (WASH PUMP)	1	1	1	1
13	Z683087000	CONTACTOR 3TF20 01-3AL2 230	CONTACTOR 3TF20 01-3AL2 230	1	1	1	1
14	Z213007000	CONTACTOR (AVANCE 1)	CONTACTOR (ADVANCE 1)	2	2	2	2

<b>MOD.</b>	<b>LAVAVAJILLAS COMPACTOS COMPACT DISHWASHERS</b>	<b>ZONA</b>	<b>CONJUNTO FUNCIONAL ELECTRICO FUNCTIONAL ELECTRIC UNIT</b>
-------------	---	-------------	--

ITEM	CODIGO	DENOMINACION	TEXTO	FI-160	FI-200	ECO-160	ECO-200
15	P663014000	SECCIONADOR 3P.125A SIEMENS	SECTIONATOR 3P.125A SIEMENS	1	1	-	-
S/Nº	P663015000	BLOQUE 4º P. SECCIONAD. 125A S.	SECTION. 125A 4º POLO SIEMENS	1	1	-	-
15	P683039000	SECCIONADOR 4P.63A SIEMENS	SECTIONATOR 4P.63A SIEMENS	-	-	1	1
16	Z313040000	SOPORTE CUADRO ELECTRICO	ELECTRIC PANEL SUPPORT	1	1	1	1
17	X183011000	CONTACTOR 3RT1024-1AN20 230	CONTACTOR 3RT1024-1AN20 230	4	4	4	4
18	Z203050000	CONTAC. SIRIUS (EXTRAC-COND.)	CONTACT. SIRIUS (EXTRAC-CON	1	1	1	1
19	Z203050000	CONTACTOR. SIRIUS (SECADO)	CONTACTOR. SIRIUS (DRYER)	1	1	1	1
20	Z123022000	TEMPORIZA. SYRELEC TRU INICIO	TIMER . SYRELEC TRU START	1	1	1	1
21	Z123022000	TEMPORI. SYRELEC TRU SECADO	TIMER . SYRELEC TRU DRYER	1	1	1	1
22	Z213007000	CONTACTOR (PUERTA)	CONTACTOR (DOOR)	1	1	1	1
23	X183011000	CONTACTOR (RESISTEC.SECADO)	CONTACTOR (DRYER RESIST.)	1	1	1	1
24	Z312966000	SOPORTE PRENSAESTOPAS	STUFFING BOX SUPPORT	1	1	1	1
25	R033002000	PRENSA ESTOPAS	STUFFING BOX	1	1	1	1
26	Z103070000	BLOQ. AUX. 3RH1921-1CA10	AUX. BLOCK 3RH1921-1CA10	1	1	1	1
27	R073005000	BORNAS PORTA FUSIBLES	FUSE HOLDER TERMINALS	2	2	2	2
	P184011000	CARTUCHO FUSIBLE 4A	FUSE CARTRIDGE 4A	2	2	2	2
	Z103029000	BORNE PAS WDU 2.5 10200-0	TERMINAL PAS WDU 2.5 10200-0	6	6	6	6
	Z263303000	TOPE FINAL	END STOP	2	2	2	2
28	R143011000	BORNA WDU-70/N REF.951219	TERMINAL WDU-70/N REF.951219	3	3	-	-
	R263003000	BORNA PASO 35MM	THROUGH TERMINAL 35MM	-	-	3	3
	P453026000	BORNE TIER 10 WPE-10103.O	TERMINAL TIER 10 WPE-10103.O	1	1	1	1
	R673010000	BORNA PASO AZUL 35MM	THROUGH TERMINAL BLUE 35MM	1	1	1	1
	Z103035000	BORNA TIERRA 35MM	EARTH TERMINAL 35MM	1	1	1	1
	Z683068000	SEÑALIZ.DEK-6WEIDMULLER	SIGNS DEK-6WEIDMULLER	1	1	1	1
	Z683096000	TOPE FINAL WEW35 10590.0	END STOP WEW35 10590.0	1	1	1	1
	Z513083000	BORNE DISTRIBUIDOR 70 MM2	DISTRIBUI. 70 MM2 TERMINAL	1	1	-	-
	Z273083000	BORNE DISTRIBUIDOR 35 MM2	DISTRIBUI. 35 MM2 TERMINAL	-	-	3	3

Зип Общепит

vsezip.ru

+7(812)987-08-81

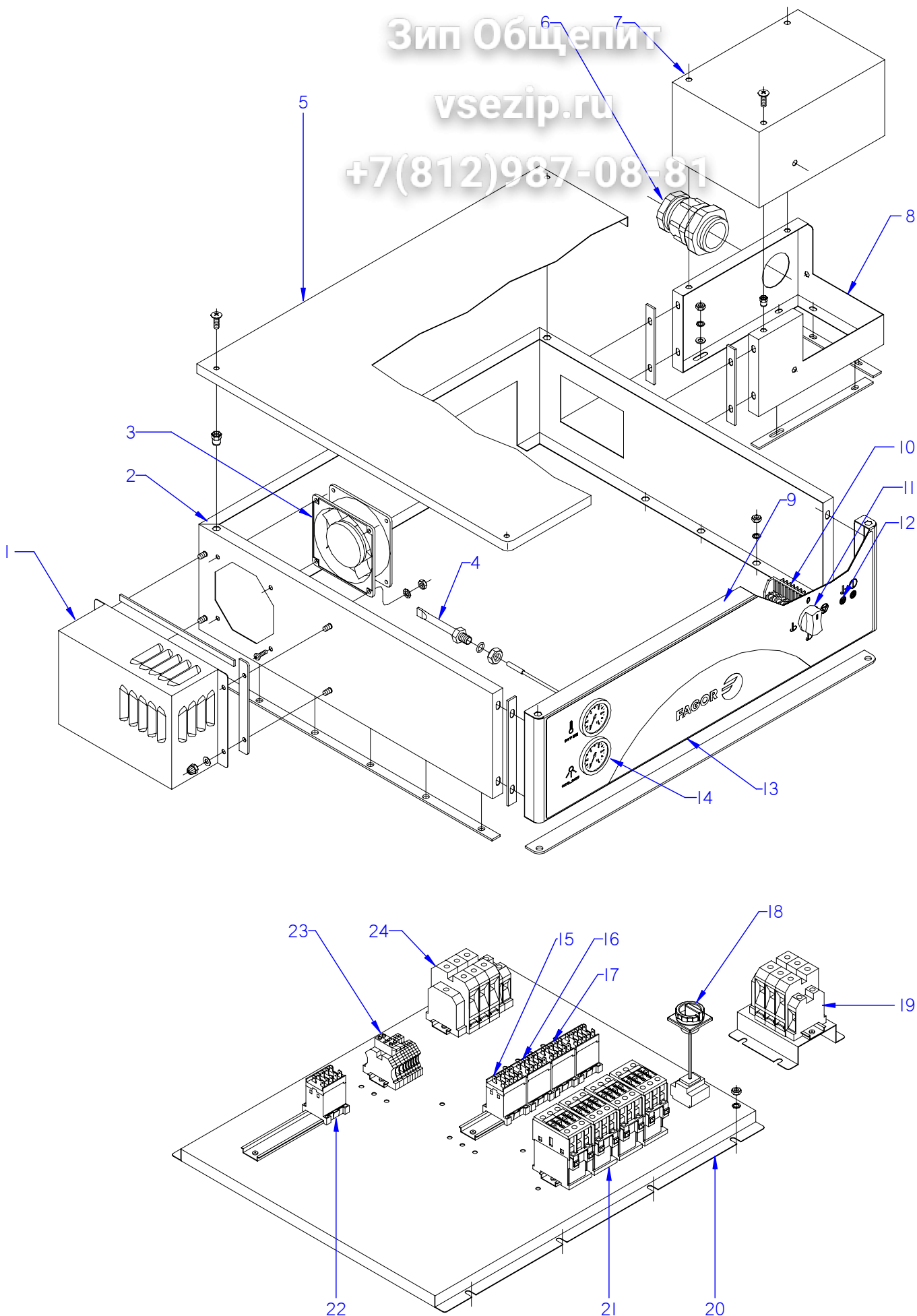

ITEM MARCADO EN COLOR = REPUESTO RECOMENDADO  
COLOURED ITEM = RECOMMENDED SPARE PART

N plano	Firma	Fecha	Aparato	CONJUNTO FUNCIONAL ELECTRICO	Lamina	Fagor Industrial S.Coop. <b>FAGOR</b>
C-2129	<i>(Signature)</i>	2008-10	LAVAVAJILLAS COMPACTOS W	10	Oñate	



MOD.	LAVAVAJILLAS COMPACTOS COMPACT DISHWASHERS	ZONA	CONJUNTO FUNCIONAL ELECTRICO FUNCTIONAL ELECTRIC UNIT
------	---	------	--

ITEM	CODIGO	DENOMINACION	TEXTO	FI-200 W				
1	Z273045000	TAPA VENTILADOR W	FAN COVER W	1				
	Z273051000	JUNTA LAT. TAPA VENTILADOR W	FAN COVER SIDE JOINT W	2				
	Z273052000	JUNTA SUP. TAPA VENTILADOR W	FAN COVER UPPER JOINT W	1				
	Q232040000	ARANDELA A6	WASHER A6	4				
	Q212040000	TUERCA SOMBRERETE M6	COWL NUT M6	4				
2	Z273041000	CUBIERTA CUADRO ELECTRIC. W	ELECTRIC PANEL COVER W	1				
2	Z273025000	CUBIERTA CUADRO ELECTRIC. W	ELECTRIC PANEL COVER W	1				
	Z273049000	JUNTA FRONTAL CUADRO ELE. W	ELEC PANEL FRONT JOINT W	2				
	Z273047000	JUNTA LATERAL CUADRO ELE. W	ELEC PANEL SIDE JOINT W	2				
3	Z103066000	VENTILADOR 230V.50-60HZ	FAN 230V.50-60HZ	1				
4	Z263002000	VAINA INDICADOR COMPLETA	COMPLETE INDICATOR SHELL	1				
	Q307048000	JUNTA TORICA 9,128x16,18x3,53	O-RING 9.128x16.18x3.53	1				
	Q162070000	TUERCA EXAGONAL M12	HEXAGONAL NUT M12	1				
5	Z313048000	TAPA CUADRO ELECTRICO	ELECTRIC PANEL COVER	1				
5	Z313093000	TAPA CUADRO ELECTRICO	ELECTRIC PANEL COVER	1				
	Q152017000	TORNILLO AMARRE M6X13 A304	FASTENING BOLT M6X13 A304	4				
6	Z312941000	PRENSA ESTOPAS PG-42	STUFFING BOX PG-42	1				
7	Z273043000	TAPA TERMINAL BOX	BOX TERMINAL COVER	1				
	Q221343000	REMACHE EXAGONAL M6	HEXAGONAL RIVET M6	5				
8	Z273042000	TERMINAL BOX	BOX TERMINAL	1				
	Z273053000	JUNTA W LATERAL TERMINAL BOX	BOX TERMINAL SIDE JOINT W	2				
	Z273054000	JUNTA W LAT INF. TERMINAL BOX	BOX TERMINAL LOW. SIDE JOINT	1				
	Z273055000	JUNTA W FRONT INF. TERMINAL B	BOX TERMINAL B LOW. FRONT J	2				
9	Z273067000	FRENTE CUADRO ELECTRICO W	ELECTRIC PANEL FRONT W	1				
9	Z273068000	FRENTE CUADRO ELECTRICO W	ELECTRIC PANEL FRONT W	1				
	Z273050000	JUNTA W FRENTE CUADRO	PANEL FRONT JOINT W	1				
	Z273048000	JUNTA W TRAS CUADRO ELEC	ELECT. PANEL REAR JOINT W	1				
10	Z273005000	COMMUTADOR DE FUNCIONES	FUNCTIONS SWITCH	1				
	Z602906000	CASQUILLO	BUSHING	2				
11	Z203069000	BOTON DE MANDO	CONTROL BUTTON	1				
11	Z513024000	BOTON DE MANDO	CONTROL BUTTON	1				

# Зип Общепит

<b>MOD.</b>	<b>LAVAVAJILLAS COMPACTOS COMPACT DISHWASHERS</b>	<b>ZONA</b>	<b>CONJUNTO FUNCIONAL ELECTRICO FUNCTIONAL ELECTRIC UNIT</b>
-------------	---	-------------	--

ITEM	CODIGO	DENOMINACION	TEXTO	FI-200 W				
12	Z313080000	PILOTO AMBAR Ø18	AMBAR PILOT LIGHT Ø18	2				
13	Z298401000	EMBELLECEDOR ADHES. FI-200 W	ADHES. TRIM FI-200 W	1				
13	Z273070000	EMBELLECEDOR ADHES. FI-200 W	ADHES. TRIM FI-200 W	1				
14	Z273060000	TERMOMETRO W NSF	THERMOMETER W NSF	2				
15	Z213007000	CONTACTOR (BOMBA LAVADO)	CONTACTOR (WASH PUMP)	1				
16	Z683087000	CONTACTOR 3TF20 01-3AL2 230	CONTACTOR 3TF20 01-3AL2 230	1				
17	Z213007000	CONTACTOR (AVANCE 1)	CONTACTOR (ADVANCE 1)	2				
18	P663014000	SECCIONADOR 3P.125A SIEMENS	SECTIONATOR 3P.125A SIEMENS	1				
S/Nº	P663015000	BLOQUE 4º P. SECCIONAD. 125A S.	SECTION. 125A 4º POLO SIEMENS	1				
19	R143011000	BORNA WDU-70/N REF.951219	TERMINAL WDU-70/N REF.951219	3				
	Z103035000	BORNA TIERRA 35MM	EARTH TERMINAL 35MM	1				
	Z683096000	TOPE FINAL WEW35 10590.0	END STOP WEW35 10590.0	1				
	R663055000	GUIA CONTACTOR L-120	CONTACTOR GUIDE L-120	1				
	Z273044000	SOPORTE GUIA CONTACTOR	CONTACTOR GUIDE SUPPORT	1				
	Q411304000	REMACHE AVIBULB Ø4,8	AVIBULB RIVET Ø4.8	2				
20	Z313040000	SOPORTE CUADRO ELECTRICO	ELECTRIC PANEL SUPPORT	1				
21	X183011000	CONTACTOR 3RT1024-1AN20 230	CONTACTOR 3RT1024-1AN20 230	4				
22	Z213007000	CONTACTOR (PUERTA)	CONTACTOR (DOOR)	1				
23	R073005000	BORNAS PORTA FUSIBLES	FUSE HOLDER TERMINALS	2				
	Z273059000	FUSIBLE 5 A UL	FUSE 5 A UL	2				
	Z103029000	BORNE PAS WDU 2.5 10200-0	TERMINAL PAS WDU 2.5 10200-0	6				
	Z263303000	TOPE FINAL	END STOP	2				
24	R143011000	BORNA WDU-70/N REF.951219	TERMINAL WDU-70/N REF.951219	3				
	Z513083000	BORNE DISTRIBUIDOR 70 MM2	DISTRIBUI. 70 MM2 TERMINAL	1				
	P453026000	BORNE TIER 10 WPE-10103.O	TERMINAL TIER 10 WPE-10103.O	1				
	Z683096000	TOPE FINAL WEW35 10590.0	END STOP WEW35 10590.0	1				

MOD. <span style="border: 1px solid black; padding: 2px;">LAVAVAJILLAS COMPACTOS COMPACT DISHWASHERS</span>		ZONA	VARIOS / VARIOUS					
ITEM	CODIGO	DENOMINACION	TEXTO	FI-160	FI-200	ECO-160	ECO-200	FI-200 W
	Z276111000	FOLLETO DE INSTRUCCIONES FI	INSTRUCTION LEAFLET FI	1	1	_	_	_
	Z286110000	FOLLETO INSTRUCCIONES ECO	INSTRUCTION LEAFLET ECO	_	_	1	1	_
	Z276112000	FOLLETO INSTRUCCION. FI-200W	INSTRUCTION LEAFLET FI-200W	_	_	_	_	1
	Z273018000	ESQUEMA TEORICO ADHESIVO FI	THEOR. DIAGRAM LABEL FI	1	1	_	_	_
	Z283020000	ESQUEMA TEORICO ADHESI. ECO	THEORETICAL DIAGRAM LABEL	_	_	1	1	_
	Z273058000	ESQUEMA TEORICO ADHESIVO W	THEOR. DIAGRAM LABEL W	_	_	_	_	1
	Z313070000	LEYENDA ESQUEMAS COMPACTO	COMPACT DIAGRAM LEGEND	1	1	1	1	1
	Z273034000	ESQUEMA MONTAJE COMPACTO	COMPACT ASSEMBLY DIAGRAM	1	1	1	1	1
	Z275080000	MONTAJE RODAMIEN. ARRASTRE	DRIVE BEARING ASSEMBLY	1	1	1	1	1
	Z273030000	INSTALACION ELECTRICA BASE	ELECTRIC INSTALLATION BASE	1	1	1	1	_
	Z273056000	INSTALACION ELECTRICA W BASE	ELECTRIC INSTALLATION W BAS	_	_	_	_	1
	Z273031000	INSTALAC. ELECTRICA CALDERIN	BOILER ELECTRIC INSTALLATIO	1	1	_	_	_
	Z273057000	INSTAL. ELECTRICA W CALDERIN	BOILER W ELECTRIC INSTALLAT	_	_	_	_	1
	Z273032000	INSTALACION VELOCIDAD II	SPEED INSTALLATION II	_	1	_	1	1
	Z323001000	CABLEADO ECO-280	WIRING ECO-280	_	_	1	1	_
	Z718416000	CABLEADO ELECTROVALVULA W	SOLENOID VALVE WIRING W	_	_	_	_	1
	Z273016000	MICRO FIN DE CARRERA	LIMIT SWITCH MICRO	1	1	1	1	1
	Z273085000	CABLEADO SECCIONADOR 125A	SECTIONATOR 125A WIRING	1	1	_	_	1
	Z273084000	CABLEADO SECCIONADOR 63A	SECTIONATOR 63A WIRING	_	_	1	1	_

Зип Общепит

vsezip.ru

+7(812)987-08-81

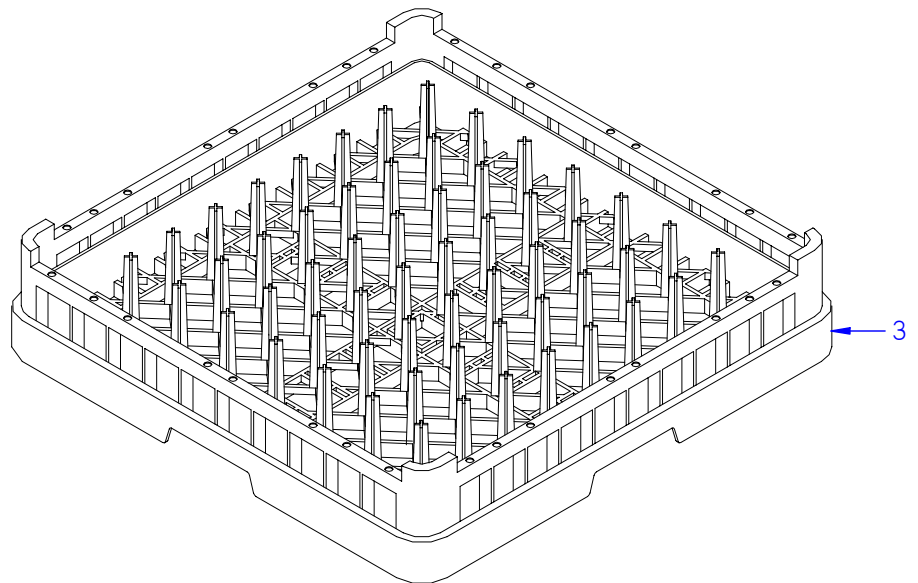
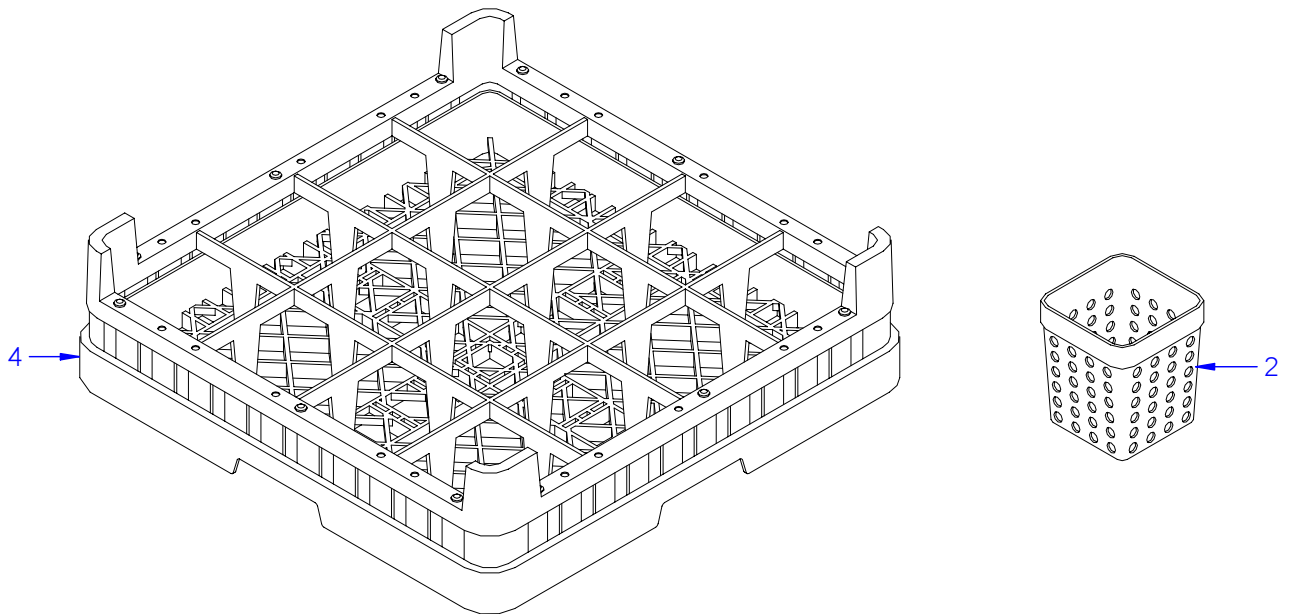
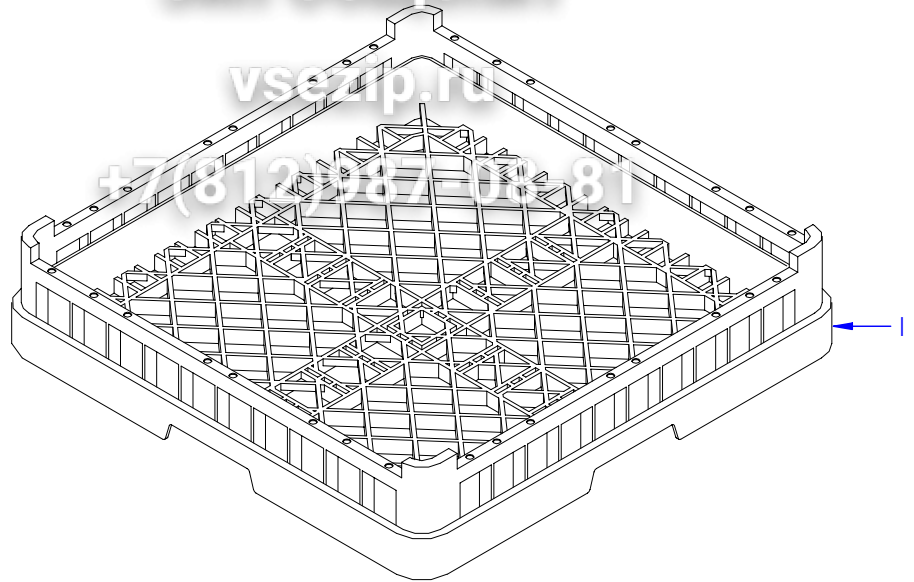

ITEM MARCADO EN COLOR = REPUESTO RECOMENDADO  
COLOURED ITEM = RECOMMENDED SPARE PART

N plano	Firma	Fecha	Aparato	CESTILLOS	Lamina	Fagor Industrial S.Coop. <b>FAGOR</b>
C-2130	<i>(Signature)</i>	2008-10	LAVAVAJILLAS COMPACTOS	11	Oñate	



Зип Общепит

vsezip.ru

+7(812)987-08-81

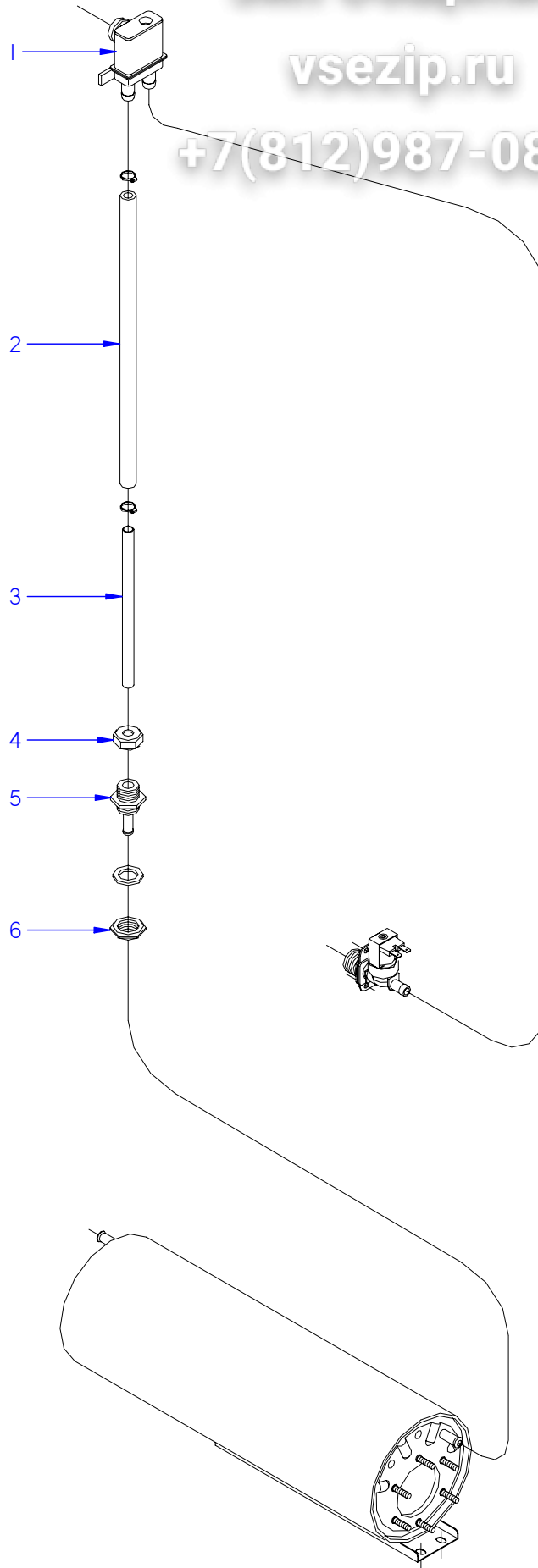

ITEM MARCADO EN COLOR = REPUESTO RECOMENDADO  
COLOURED ITEM = RECOMMENDED SPARE PART

N plano	Firma	Fecha	Aparato	VALVULA ANTIRRETORNO	Lamina	Fagor Industrial S.Coop. <b>FAGOR</b>
C-2131	<i>name (ben)</i>	2008-10	LAVAVAJILLAS COMPACTOS A.R.	12	Oñate	



Зип Общепит

vsezip.ru

+7(812)987-08-81

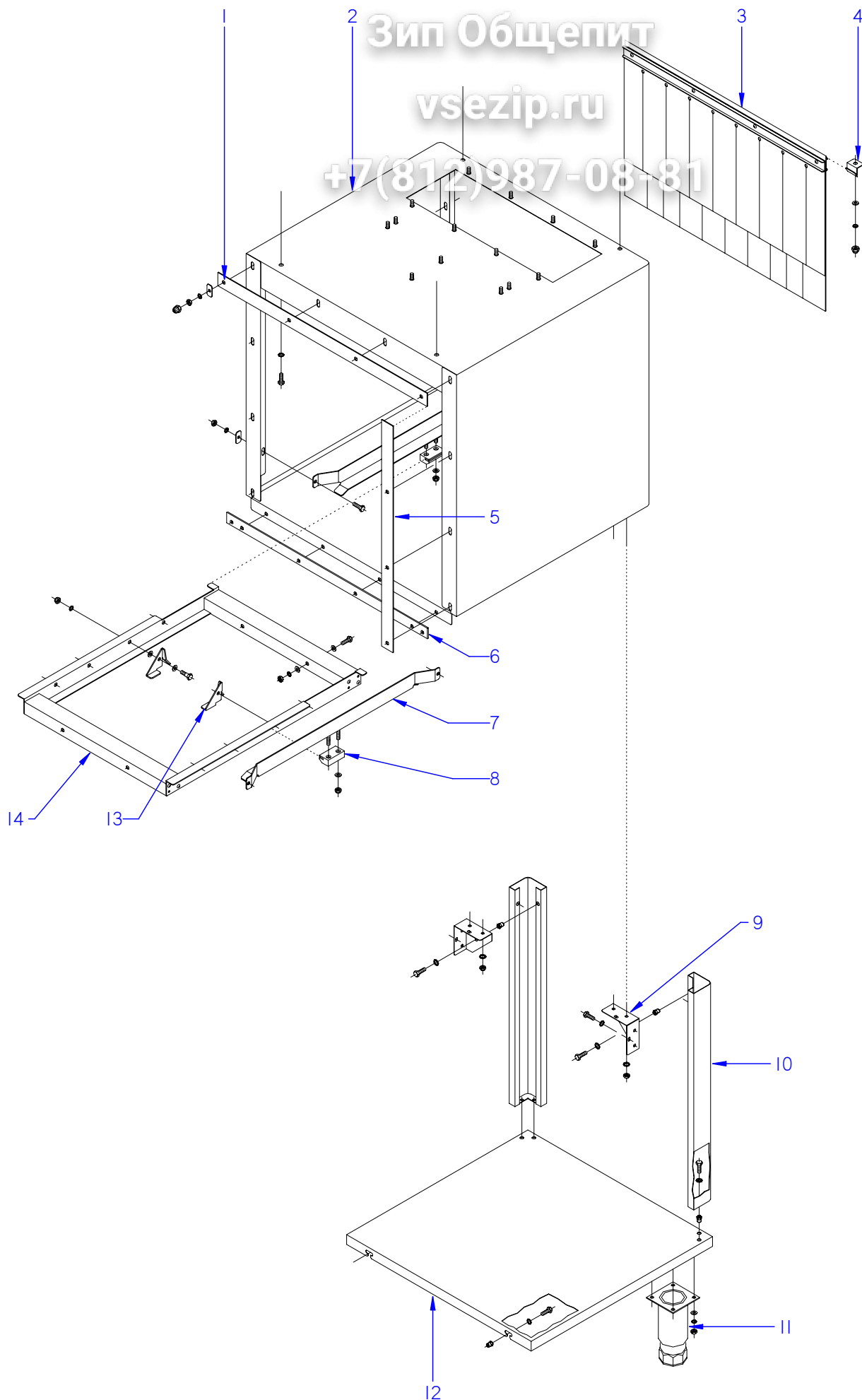

ITEM MARCADO EN COLOR = REPUESTO RECOMENDADO  
COLOURED ITEM = RECOMMENDED SPARE PART

N plano	Firma	Fecha	Aparato	TUNEL DE SECADO	Lamina	Fagor Industrial S.Coop. <b>FAGOR</b>
C-2132	<i>(Signature)</i>	2008-10	LAVAVAJILLAS COMPACTOS		13	Oñate



Зип Общепит

vsezip.ru

+7(812)987-08-81

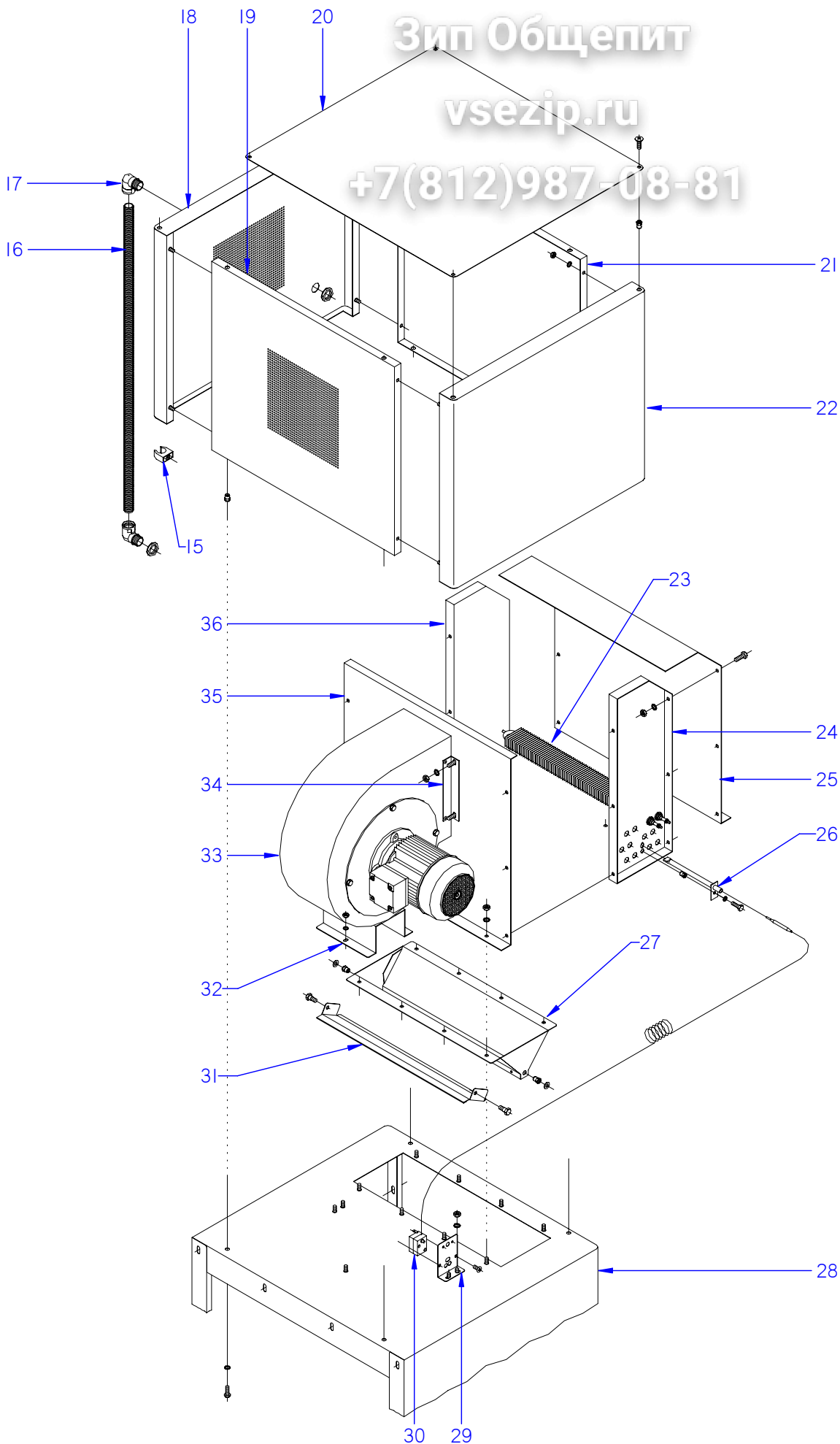

ITEM MARCADO EN COLOR = REPUESTO RECOMENDADO  
COLOURED ITEM = RECOMMENDED SPARE PART

N plano	Firma	Fecha	Aparato	SECADO	Lamina	Fagor Industrial S.Coop. <b>FAGOR</b>
C-2133	<i>(Signature)</i>	2008-10	LAVAVAJILLAS COMPACTOS		14	Oñate

MOD.	LAVAVAJILLAS COMPACTOS COMPACT DISHWASHERS	ZONA	TUNEL DE SECADO / DRYING TUNNEL
------	---	------	---------------------------------

ITEM	CODIGO	DENOMINACION	TEXTO	TUNEL DE SECADO				
1	Z276206000	JUNTA SUPERIOR COMPACTO**	COMPACT UPPER JOINT**	1				
	Q302022000	ARANDELA 16X6X1.2 A.304	WASHER 16X6X1.2 A.304	4				
	Q262040000	ARANDELA GROW. A6 A304	WASHER GROW. A6 A304	4				
	Q162040000	TUERCA EXAGONAL M6	HEXAGONAL NUT M6	12				
2	Z276301000	TUNEL SECADO SOLDADO	WELDED DRYER TUNNEL	1				
3	Z276429000	CORTINA INTERIOR COMPLETA	COMPLETE INTERIOR CURTAIN	1				
4	Z270326000	SUJECION CORTINA	CURTAIN FASTENING	2				
	Q262030000	ARANDELA GROW. A5 A.304	WASHER GROW. A5 A.304	2				
	Q232040000	ARANDELA A6	WASHER A6	2				
	Q212031000	TUERCA SOMBRERETE M5	COWL NUT M5	2				
5	Z276208000	JUNTA LATERAL COMPACTO**	COMPACT SIDE JOINT**	2				
	Q302022000	ARANDELA 16X6X1.2 A.304	WASHER 16X6X1.2 A.304	8				
	Q262040000	ARANDELA GROW. A6 A304	WASHER GROW. A6 A304	8				
	Q162040000	TUERCA EXAGONAL M6	HEXAGONAL NUT M6	8				
6	Z276207000	JUNTA INFERIOR COMPACTO**	COMPACT LOWER JOINT **	1				
	Q302022000	ARANDELA 16X6X1.2 A.304	WASHER 16X6X1.2 A.304	4				
	Q262040000	ARANDELA GROW. A6 A304	WASHER GROW. A6 A304	4				
	Q162040000	TUERCA EXAGONAL M6	HEXAGONAL NUT M6	4				
7	Z276309000	GUIA DE SECADO COMPLETO	COMPLETE DRYER GUIDE	2				
8	Z275075000	DESLIZAMIENTO GUIAS	GUIDE SLIDE	4				
	Q232040000	ARANDELA A6	WASHER A6	8				
	Q222012000	TUERCA AUTOBLOCANTE M6	SELF-LOCKING NUT M6	8				
	Q012042000	TORNILLO EXAGONAL M6X15 A304	HEXAGONAL BOLT M6x15 A304	4				
	Q262040000	ARANDELA GROW. A6 A304	WASHER GROW. A6 A304	4				
	Z310341000	ARANDELA RECTANGULAR	RECTANGULAR WASHER	4				
	Q162040000	TUERCA EXAGONAL M6	HEXAGONAL NUT M6	4				
9	Z276354000	AMARRE PATA	LEG FASTENING	2				
	Q262040000	ARANDELA GROW. A6 A304	WASHER GROW. A6 A304	4				
	Q162040000	TUERCA EXAGONAL M6	HEXAGONAL NUT M6	4				
10	Z276395000	PATA TUNEL SECADO COMPLETA	COMPLETE DRYER TUNNEL LEG	2				

MOD.	LAVAVAJILLAS COMPACTOS COMPACT DISHWASHERS	ZONA	TUNEL DE SECADO / DRYING TUNNEL
------	---	------	---------------------------------

ITEM	CODIGO	DENOMINACION	TEXTO	TUNEL DE SECADO				
11	X260151000	PATA REGULABLE	ADJUSTABLE LEG	2				
	Q302022000	ARANDELA 16X6X1.2 A.304	WASHER 16X6X1.2 A.304	8				
	Q262040000	ARANDELA GROW. A6 A.304	WASHER GROW. A6 A.304	8				
	Q162040000	TUERCA EXAGONAL M6	HEXAGONAL NUT M6	8				
12	Z276398000	BANDEJA TUNEL SECADO COMPL.	COMPL. DRYER TUNNEL TRAY	1				
	Q221342000	REMACHE EXAGONAL M5	HEXAGONAL RIVET M5	8				
	Q242030000	ARANDELA ABANICO A5 A.304	FAN WASHER A5 A.304	8				
	Q012031000	TORNILLO EXAGONAL M5X10 A304	HEXAGONAL BOLT M5x10 A304	8				
13	Z275077000	UNA ARRASTRE IZQUIERDA LASER	LASER LEFT DRAG CLAW	5				
S/Nº	Z275078000	UNA ARRASTRE DERECHA LASER	LASER RIGHT DRAG CLAW	5				
	Q232050000	ARANDELA A8	WASHER A8	20				
	Q152046000	TORNILLO EXAGON. CON CUELLO	HEXAGONAL BOLT. WITH NECK	10				
	Q232040000	ARANDELA A6	WASHER A6	10				
	Q222012000	TUERCA AUTOBLOCANTE M6	SELF-LOCKING NUT M6	10				
14	Z276311000	SOPORTE UNA SECADO COMPL.	COMPL. DRYER CLAY SUPPORT	1				
	Q012042000	TORNILLO EXAGONAL M6X15 A304	HEXAGONAL BOLT M6x15 A304	2				
	Q232050000	ARANDELA A8	WASHER A8	4				
	Q232040000	ARANDELA A6	WASHER A6	2				
	Q222012000	TUERCA AUTOBLOCANTE M6	SELF-LOCKING NUT M6	2				
15	Z316354000	ABRAZADERA DE PRESION	PRESSURE CLAMP	2				
16	3712300000	TUBO PG21 0233.204.023	PIPE PG21 0233.204.023	1				
17	Z703006000	RACORD A 90 SFWO-P213T	CONNECTION A 90 SFWO-P213T	2				
	R023025000	CONTRATUERCA (GAES)	COUNTERNUT (GAES)	2				
18	Z276361000	POSTERIOR CUBIERTA COMPLET.	COMPLET. REAR COVER	1				
19	Z276345000	LATERAL CUBIERTA	SIDE COVER	1				
20	Z276346000	TAPA CUBIERTA	COVER LID	1				
	Q262040000	ARANDELA GROW. A6 A.304	WASHER GROW. A6 A.304	16				
	Q162040000	TUERCA EXAGONAL M6	HEXAGONAL NUT M6	16				
	Q152017000	TORNILLO AMARRE M6X13 A304	FASTENING BOLT M6X13 A304	4				
	Q221343000	REMACHE EXAGONAL M6	HEXAGONAL RIVET M6	8				
21	Z276751000	LATERAL CUBIERTA	SIDE COVER	4				

MOD.	LAVAVAJILLAS COMPACTOS COMPACT DISHWASHERS	ZONA	TUNEL DE SECADO / DRYING TUNNEL
------	---	------	---------------------------------

ITEM	CODIGO	DENOMINACION	TEXTO	TUNEL DE SECADO				
22	Z276342000	ANTERIOR CUBIERTA COMPLETA	COMPLET E FRONT COVER	1				
23	Z276391000	RESISTENCIA ALETAS 1500W 230V	FIN RESISTOR 1500W 230V	6				
	Q221305000	TUERCA EXG. AUTO M4 ZINCADA	HEXAG. NUT AUTO M4 ZINC-COA	12				
24	Z276329000	FRONTAL CAJA RESISTENCIA	RESISTOR BOX FRONT	1				
25	Z276326000	LATERAL IZDO. CAJA RESISTENC.	LEFT SIDE RESISTOR BOX	1				
26	Z276331000	VAINA TS. COMPLETA	COMPLETE TS. SHELL	1				
	Q012042000	TORNILLO EXAGONAL M6X15 A304	HEXAGONAL BOLT M6x15 A304	1				
	Q262040000	ARANDELA GROW. A6 A.304	WASHER GROW. A6 A.304	1				
	Q221343000	REMACHE EXAGONAL M6	HEXAGONAL RIVET M6	1				
27	Z276315000	SALIDA SECADO SOLDADO	WELDED DRYER OUTPUT	1				
	Q262040000	ARANDELA GROW. A6 A.304	WASHER GROW. A6 A.304	8				
	Q162040000	TUERCA EXAGONAL M6	HEXAGONAL NUT M6	16				
28	Z276301000	TUNEL SECADO SOLDADO	WELDED DRYER TUNNEL	1				
29	Z203047000	SOPORTE TERMOSTATOS	THERMOSTAT SUPPORT	1				
	Q232040000	ARANDELA A6	WASHER A6	2				
	Q162040000	TUERCA EXAGONAL M6	HEXAGONAL NUT M6	2				
	Q152024000	TORNILLO AVELLANADO M4X8	COUNTERSUNK BOLT M4x8	2				
30	Z203060000	TERMOSTATO 150°C	THERMOSTAT 150°C	1				
31	Z276318000	TAPA SALIDA SECADO	DRYER OUTPUT LID	1				
	Q302022000	ARANDELA 16X6X1.2 A.304	WASHER 16X6X1.2 A.304	2				
	Q152046000	TORNILLO EXAGON. CON CUELLO	HEXAGONAL BOLT. WITH NECK	2				
32	Z276394000	SOPORTE VENTILADOR	FAN BRACKET	1				
	Q082005000	TORNILLO CHAP. Ø4,2X13 4.2X13	PLATE BOLT Ø4.2X13 4.2X13	4				
	Q262040000	ARANDELA GROW. A6 A.304	WASHER GROW. A6 A.304	6				
	Q162040000	TUERCA EXAGONAL M6	HEXAGONAL NUT M6	6				
33	Z316412000	VENTILADOR CENTRIFUGO	SPIN FAN	1				
34	Z276375000	AMARRE VENTILADOR	FAN FASTENING	2				
35	Z276376000	LATERAL DCHO.CAJA RESISTENC.	RIGHT SIDE RESISTOR BOX.	1				

# Зип ОццелпТ

MOD.

LAVAVAJILLAS COMPACTOS  
COMPACT DISHWASHERS

ZONA

vsezip.ru

TUNEL DE SECADO / DRYING TUNNEL

+7(812)987-08-81

ITEM	CODIGO	DENOMINACION	TEXTO	TUNEL DE SECADO				
36	Z276330000	POSTERIOR CAJA RESISTENCIA	REAR RESISTOR BOX	1				
	Q012042000	TORNILLO EXAGONAL M6X15 A304	HEXAGONAL BOLT M6x15 A304	14				
	Q262040000	ARANDELA GROW. A6 A.304	WASHER GROW. A6 A.304	14				
	Q221343000	REMACHE EXAGONAL M6	HEXAGONAL RIVET M6	14				
S/N°	Z316381000	CABLEADO SECADO	DRYER WIRING	1				
S/N°	Z316382000	CABLEADO AUXILIAR SECADO	AUX. DRYER WIRING	1				

Зип Общепит

vsezip.ru

+7(812)98770881

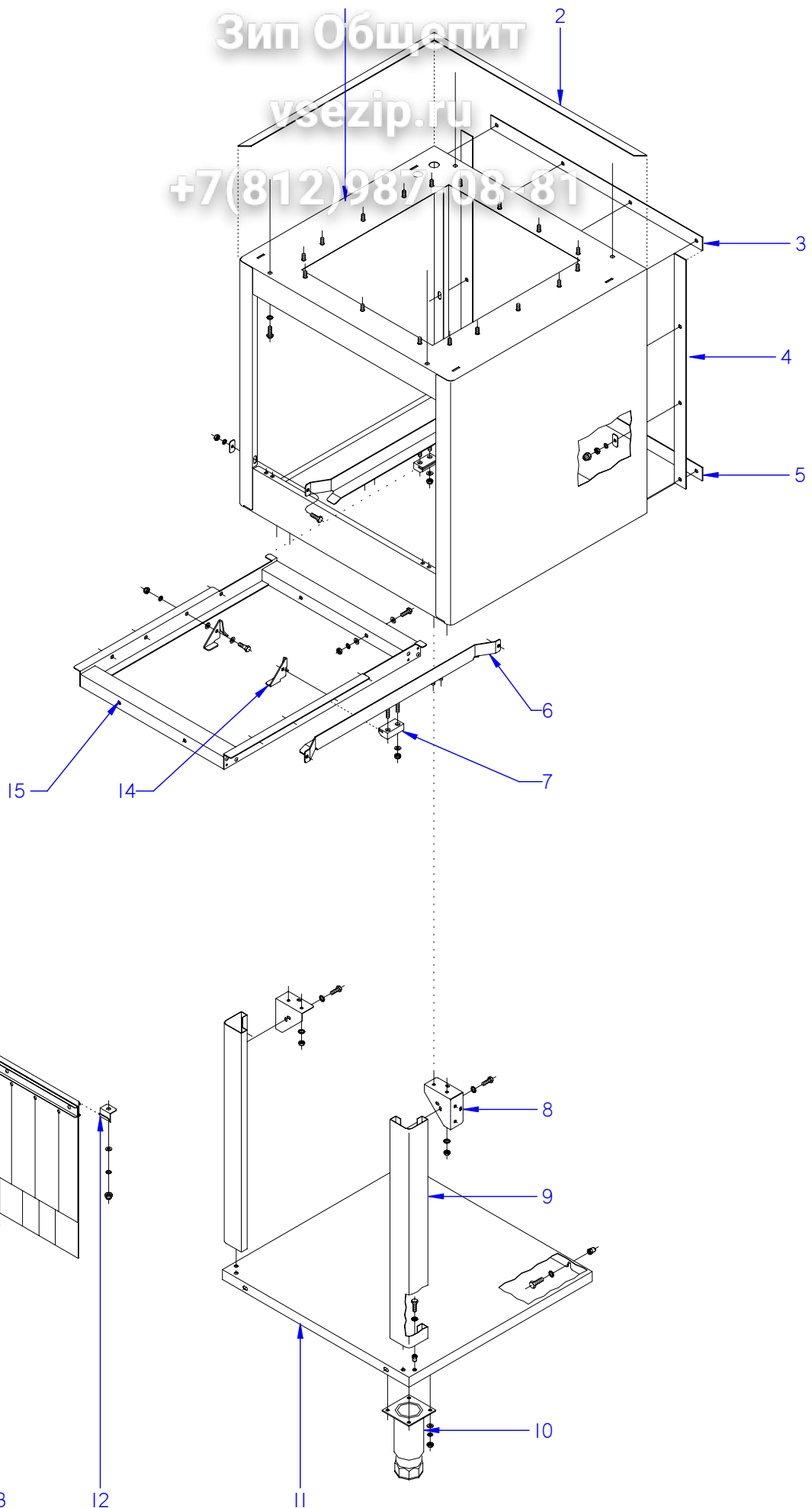

ITEM MARCADO EN COLOR = REPUESTO RECOMENDADO  
COLOURED ITEM = RECOMMENDED SPARE PART

N plano	Firma	Fecha	Aparato	TUNEL CONDENSADOR DE VAHOS	Lamina	Fagor Industrial S.Coop. <b>FAGOR</b>
C-2134	<i>[Signature]</i>	2008-10	LAVAVAJILLAS COMPACTOS	15	Oñate	

Зип Общежит

vsezip.ru

+7(812)987-08-81

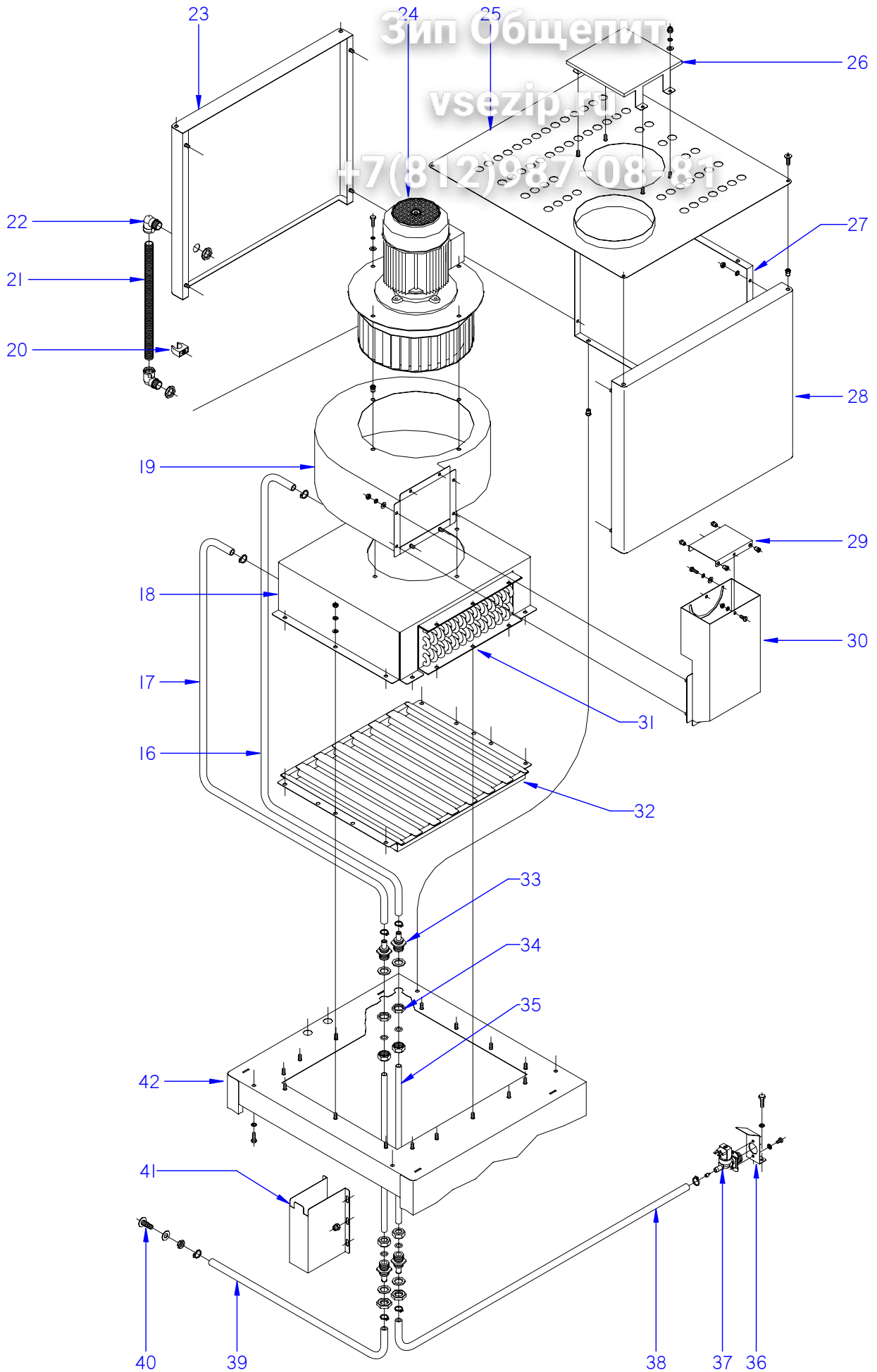

ITEM MARCADO EN COLOR = REPUESTO RECOMENDADO  
COLOURED ITEM = RECOMMENDED SPARE PART

N plano	Firma	Fecha	Aparato	CONDENSADOR DE VAHOS	Lamina	Fagor Industrial S.Coop. <b>FAGOR</b>
C-2135	<i>[Signature]</i>	2008-10	LAVAVAJILLAS COMPACTOS		16	Oñate

MOD.		LAVAVAJILLAS COMPACTOS COMPACT DISHWASHERS		ZONA	TUNEL CONDENSADOR DE VAHOS STEAM CONDENSER TUNNEL			
ITEM	CODIGO	DENOMINACION	TEXTO	TUNEL COND. DE VAHOS				
1	Z276732000	TUNEL CONDENSADOR DE VAHOS	COMP STEAM CONDENSOR TUN	1				
	Z276520000	PROTECTOR SUPERIOR SOLDAD.	WELDED UPPER PROTECTOR	1				
2	Z270334000	PERFIL	PROFILE	4				
3	Z276206000	JUNTA SUPERIOR COMPACTO**	COMPACT UPPER JOINT**	1				
4	Z276208000	JUNTA LATERAL COMPACTO**	COMPACT SIDE JOINT**	2				
5	Z276207000	JUNTA INFERIOR COMPACTO**	COMPACT LOWER JOINT **	1				
	Q302022000	ARANDELA 16X6X1.2 A.304	WASHER 16X6X1.2 A.304	12				
	Q262040000	ARANDELA GROW. A6 A304	WASHER GROW. A6 A304	12				
	Q162040000	TUERCA EXAGONAL M6	HEXAGONAL NUT M6	12				
	Q212040000	TUERCA SOMBRERETE M6	COWL NUT M6	10				
6	Z276309000	GUIA DE SECADO COMPLETO	COMPLETE DRYER GUIDE	2				
7	Z275075000	DESGLIZAMIENTO GUIAS	GUIDE SLIDE	4				
	Q232040000	ARANDELA A6	WASHER A6	8				
	Q222012000	TUERCA AUTOBLOCANTE M6	SELF-LOCKING NUT M6	8				
	Q012042000	TORNILLO EXAGONAL M6X15 A304	HEXAGONAL BOLT M6x15 A304	4				
	Q262040000	ARANDELA GROW. A6 A304	WASHER GROW. A6 A304	4				
	Z310341000	ARANDELA RECTANGULAR	RECTANGULAR WASHER	4				
	Q162040000	TUERCA EXAGONAL M6	HEXAGONAL NUT M6	4				
8	Z276354000	AMARRE PATA	LEG FASTENING	2				
	Q262040000	ARANDELA GROW. A6 A304	WASHER GROW. A6 A304	4				
	Q162040000	TUERCA EXAGONAL M6	HEXAGONAL NUT M6	4				
9	Z276395000	PATA TUNEL SECADO COMPLETA	COMPLETE DRYER TUNNEL LEG	2				
10	X260151000	PATA REGULABLE	ADJUSTABLE LEG	2				
	Q302022000	ARANDELA 16X6X1.2 A.304	WASHER 16X6X1.2 A.304	8				
	Q262040000	ARANDELA GROW. A6 A.304	WASHER GROW. A6 A.304	8				
	Q162040000	TUERCA EXAGONAL M6	HEXAGONAL NUT M6	8				
11	Z276398000	BANDEJA TUNEL SECADO COMPL.	COMPL. DRYER TUNNEL TRAY	1				
	Q221342000	REMACHE EXAGONAL M5	HEXAGONAL RIVET M5	8				
	Q242030000	ARANDELA ABANICO A5 A.304	FAN WASHER A5 A.304	8				
	Q012031000	TORNILLO EXAGONAL M5X10 A304	HEXAGONAL BOLT M5x10 A304	8				



MOD.		LAVAVAJILLAS COMPACTOS COMPACT DISHWASHERS	ZONA	TUNEL CONDENSADOR DE VAHOS STEAM CONDENSER TUNNEL				
ITEM	CODIGO	DENOMINACION	TEXTO	TUNEL COND. DE VAHOS				
12	Z270326000	SUJECION CORTINA	CURTAIN FASTENING	2				
	Q262030000	ARANDELA GROW. A5 A.304	WASHER GROW. A5 A.304	2				
	Q232040000	ARANDELA A6	WASHER A6	2				
13	Z276419000	CORTINA EXTERIOR COMPLETA	COMPLETE EXTERIOR CURTAIN	1				
14	Z275077000	UNA ARRASTRE IZQUIERDA LASER	LASER LEFT DRAG CLAW	5				
S/Nº	Z275078000	UNA ARRASTRE DERECHA LASER	LASER RIGHT DRAG CLAW	5				
	Q232050000	ARANDELA A8	WASHER A8	20				
	Q152046000	TORNILLO EXAGON. CON CUELLO	HEXAGONAL BOLT. WITH NECK	10				
	Q232040000	ARANDELA A6	WASHER A6	10				
	Q222012000	TUERCA AUTOBLOCANTE M6	SELF-LOCKING NUT M6	10				
	Z276311000	SOPORTE UNA SECADO COMPL.	COMPL. DRYER CLAY SUPPORT	1				
	Q012042000	TORNILLO EXAGONAL M6X15 A304	HEXAGONAL BOLT M6x15 A304	2				
	Q232050000	ARANDELA A8	WASHER A8	4				
	Q232040000	ARANDELA A6	WASHER A6	2				
	Q222012000	TUERCA AUTOBLOCANTE M6	SELF-LOCKING NUT M6	2				
16	3676900000	TUBO GOMA NEGRA Ø 17*10	BLACK RUBBER PIPE 17*10	1				
	Q881302000	ABRAZADERA 12-20	CLAMP 12-20	2				
17	3676900000	TUBO GOMA NEGRA Ø 17*10	BLACK RUBBER PIPE 17*10	1				
	Q881302000	ABRAZADERA 12-20	CLAMP 12-20	2				
18	Z276741000	CUBIERTA BATERIA	BATTERY COVER	1				
	Q221343000	REMACHE EXAGONAL M6	HEXAGONAL RIVET M6	4				
	Q262040000	ARANDELA GROW. A6 A.304	WASHER GROW. A6 A.304	12				
	Q162040000	TUERCA EXAGONAL M6	HEXAGONAL NUT M6	12				
19	Z276742000	CUBIERTA VENTOLA COMPLETA	COMPLETE VENTOLA COVER	1				
	Q221343000	REMACHE EXAGONAL M6	HEXAGONAL RIVET M6	8				
20	Z316354000	ABRAZADERA DE PRESION	PRESSURE CLAMP	2				
21	3712300000	TUBO PG21 0233.204.023	PIPE PG21 0233.204.023	1				
22	Z703006000	RACORD A 90 SFWO-P213T	CONNECTION A 90 SFWO-P213T	2				
	R023025000	CONTRATUERCA (GAES)	COUNTERNUT (GAES)	2				
23	Z276752000	POSTERIOR CUBIERTA COMPL.	COMPLET. REAR COVER	1				
24	Z276760000	VENTILADOR CENTRIFUGO	SPIN FAN	1				

MOD.		LAVAVAJILLAS COMPACTOS COMPACT DISHWASHERS	ZONA	TUNEL CONDENSADOR DE VAHOS STEAM CONDENSER TUNNEL				
ITEM	CODIGO	DENOMINACION	TEXTO	TUNEL COND. DE VAHOS				
25	Z276756000	TAPA CUBIERTA COMPLETA	COMPLETE COVER LID	1				
	Q152017000	TORNILLO AMARRE M6X13 A304	FASTENING BOLT M6X13 A304	4				
	Q221343000	REMACHE EXAGONAL M6	HEXAGONAL RIVET M6	8				
26	Z276759000	CUBIERTA MOTOR	MOTOR COVER					
	Q262040000	ARANDELA GROW. A6 A.304	WASHER GROW. A6 A.304	16				
	Q162040000	TUERCA EXAGONAL M6	HEXAGONAL NUT M6	16				
27	Z276751000	LATERAL CUBIERTA	SIDE COVER	2				
28	Z276342000	ANTERIOR CUBIERTA COMPLETA	COMPLET E FRONT COVER	1				
29	Z276755000	REGULADOR SALIDA AIRE	AIR OUTPUT CONTROL	1				
	Q152047000	TORNILLO EXAGON. CON CUELLO	HEXAGONAL BOLT. WITH NECK	2				
	Q232050000	ARANDELA A8	WASHER A8	2				
	Q262030000	ARANDELA GROW. A5 A.304	WASHER GROW. A5 A.304	2				
	Q162030000	TUERCA EXAGONAL M5	HEXAGONAL NUT M5	2				
	Q222011000	REMACHE EXAGONAL M5 (INOX)	HEXAGONAL RIVET M5 (INOX)	2				
30	Z276746000	SALIDA AIRE COMPLETO	COMPLETE AIR OUTPUT	1				
	Q232040000	ARANDELA A6	WASHER A6	4				
	Q162040000	TUERCA EXAGONAL M6	HEXAGONAL NUT M6	4				
	Q262040000	ARANDELA GROW. A6 A.304	WASHER GROW. A6 A.304	12				
	Q012042000	TORN.EXA. M6X15 AISI 304	HEX BOLT M6X15 AISI 304	8				
31	Z276762000	BATERIA COMPLETA	COMPLETE BATTERY	1				
32	Z276734000	REJILLA ASPIRACION VAHOS COM.	COM. STEAM EXTRACT. GRILLE	1				
33	Z271901000	PASAMUROS ACLARADO	RINSE BUSHING	4				
	Q307032000	JUNTA 32X21X3	JOINT 32X21X3	4				
34	Q223031000	TUERCA M.24x2.5	NUT M.24X2.5	2				
	Q223023000	TUERCA EXAGONAL 5-8 LATON	HEX NUT 5-8 BRASS	2				
35	Z276761000	TUBO EMPALME	CONNECTION PIPE	2				
	Q307063000	JUNTA TORICA 12.29X19.35X3.53	O-RING 12.29X19.35X3.53	4				
	Q223108000	TUERCA M.24X2.5	NUT M.24X2.5	4				

MOD.		LAVAVAJILLAS COMPACTOS COMPACT DISHWASHERS		ZONA	TUNEL CONDENSADOR DE VAHOS STEAM CONDENSER TUNNEL		
ITEM	CODIGO	DENOMINACION	TEXTO	TUNEL COND. DE VAHOS			
36	Z201101000	ESCUADRA AMARRE ELECTROVA	SOLENOID VALVE BRACKET	1			
	Q032021000	TORNILLO ALOMADO M4X10	CURVED SCREW M4X10	2			
	Q232020000	ARANDELA A-4	WASHER A-4	2			
	Q242020000	ARANDELA ABANICO A.4 A304	FAN WASHER A.4 A304	2			
	Q012042000	TORNILLO EXAGONAL M6X15 A304	HEXAGONAL BOLT M6x15 A304	2			
	Q262040000	ARANDELA GROW. A6 A.304	WASHER GROW. A6 A.304	14			
37	Z106811000	ELECTROVALVULA MONTADA	SOLENOID VALVE MOUNTED	1			
38	3676900000	TUBO GOMA NEGRA Ø 17*10	BLACK RUBBER PIPE 17*10	1			
	Q881302000	ABRAZADERA 12-20	CLAMP 12-20	2			
39	3676900000	TUBO GOMA NEGRA Ø 17*10	BLACK RUBBER PIPE 17*10	1			
	Q881302000	ABRAZADERA 12-20	CLAMP 12-20	2			
40	Z600907000	TOMA DE PRESION	PRESSURE CONNECTION	1			
	Z600908000	ARANDELA	WASHER	1			
	Q223013000	TUERCA	NUT	1			
41	Z276772000	CUBIERTA	COVER	1			
	Q152014000	PERNO SOLDADO M5X10	WELDED BOLT M5X10	6			
	Q212031000	TUERCA SOMBRERETE M5	COWL NUT M5	6			
42	Z276732000	TUNEL CONDENSADOR DE VAHOS	COMP STEAM CONDENSOR TUN	1			
S/Nº	Z316702000	CABLEADO CONDENSADOR	CONDENSOR WIRING	1			







# FI-160 FI-160AR FI-200 FI-200AR FI-200H FI-2

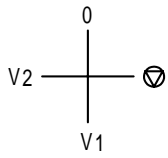
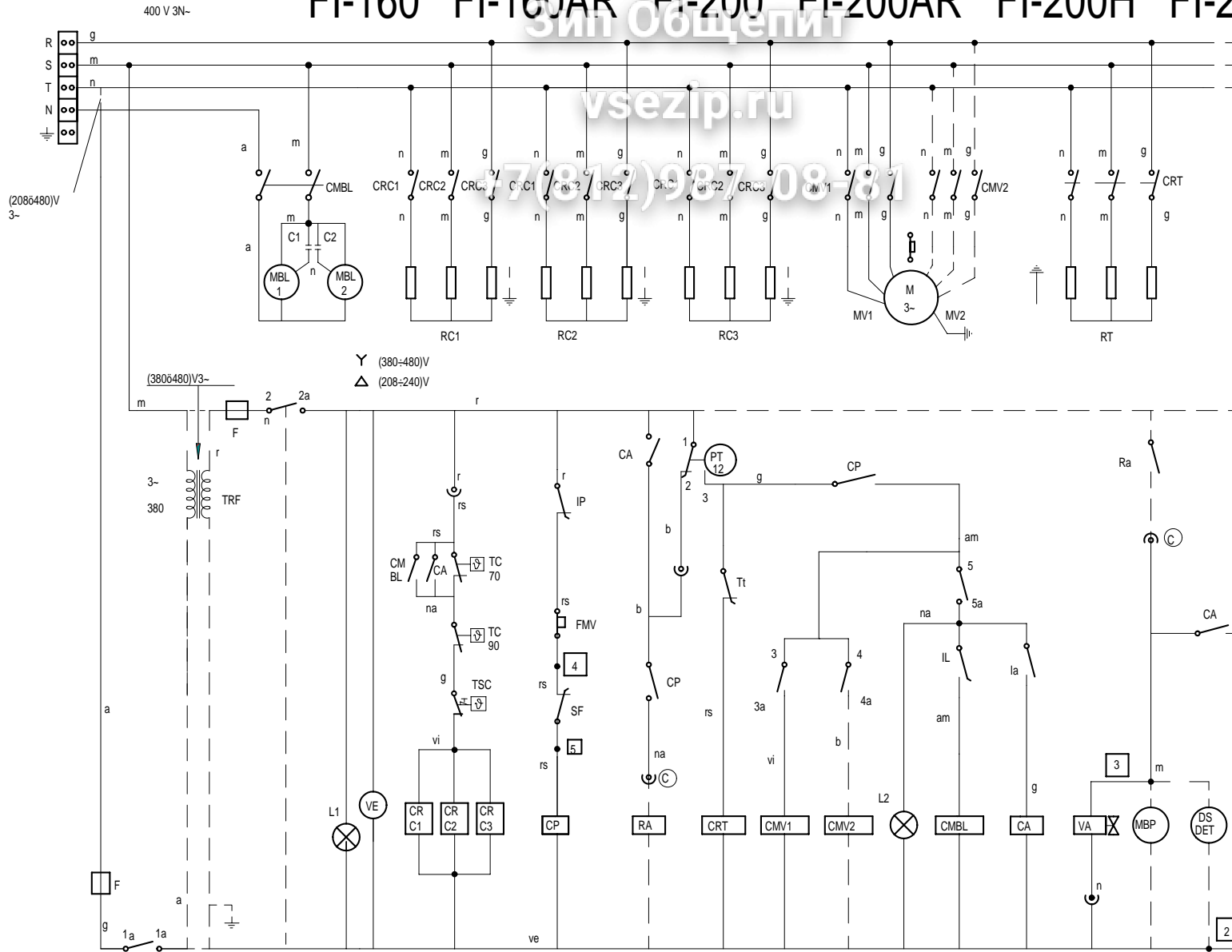

IG	1 1a	2 2a	3 3a	4 4a	5 5a
0					
⊗	X	X			
V1	X	X	X		X X
V2	X	X		X	X X

# ECO -160 ECO -200 ECO -200H

Зип Общепит

vsezip.ru

+7(812)987-08-81

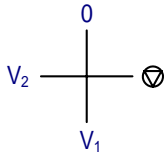
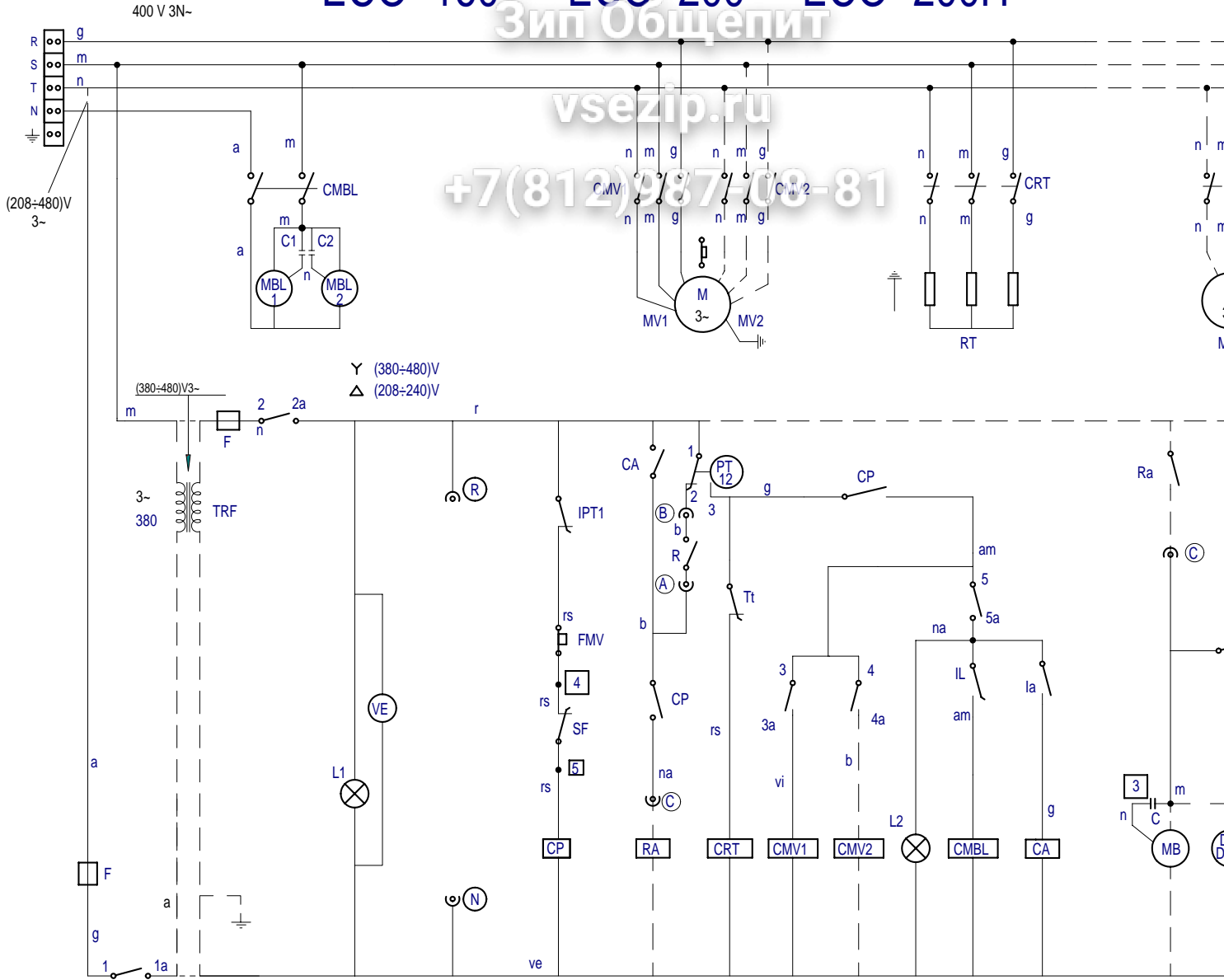

IG	1 1a	2 2a	3 3a	4 4a	5 5a	
0						
⚡	X	X				
V <sub>1</sub>	X	X	X		X	X
V <sub>2</sub>	X	X		X	X	X



# Зип Общепит FI-200 W

vsezip.ru

+7(812)987-08-81

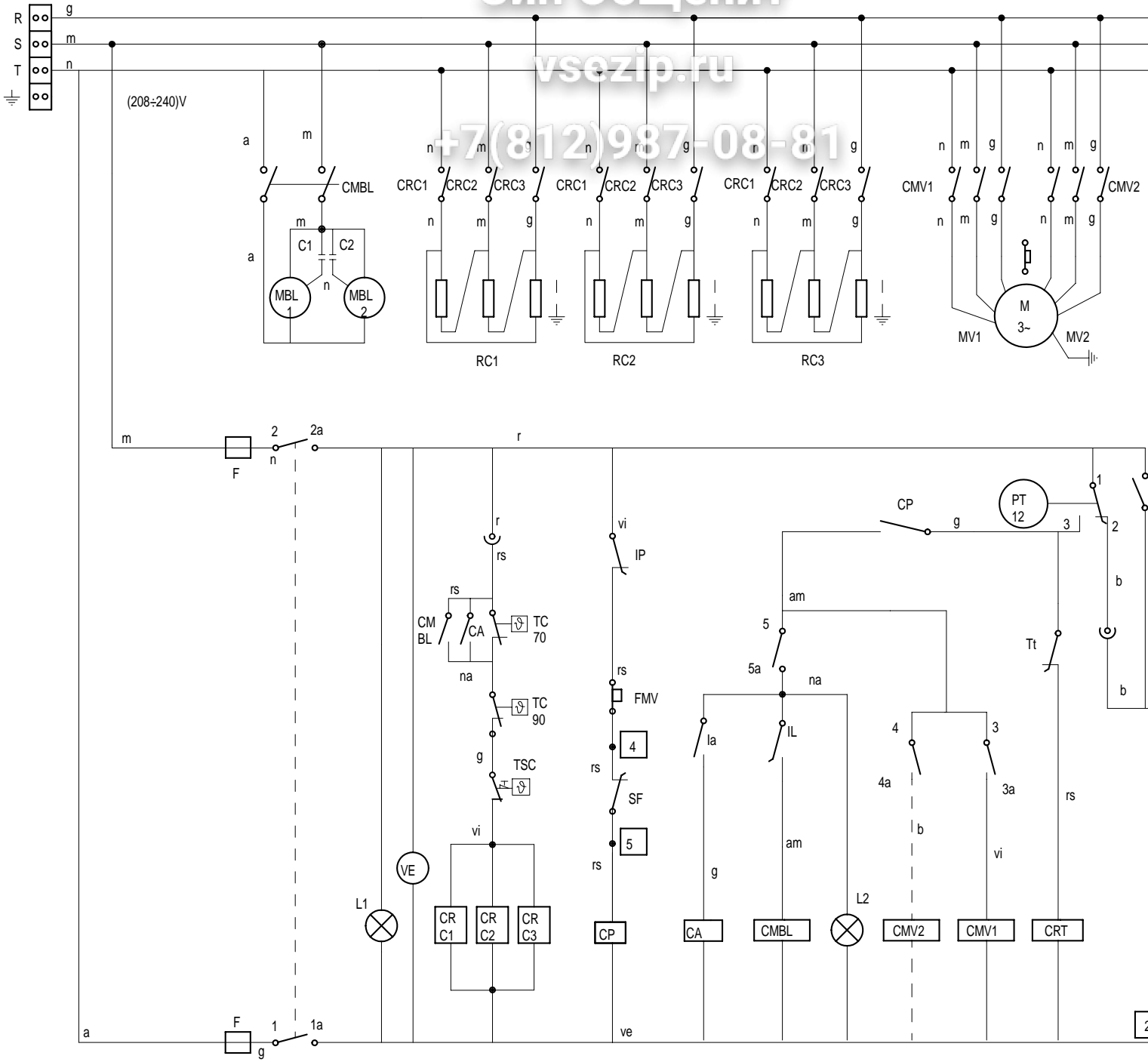

# CONDENS.

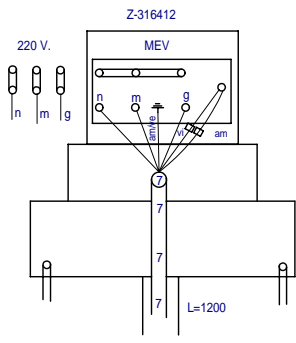

## 380-480 V 3- SIN NEUTRO

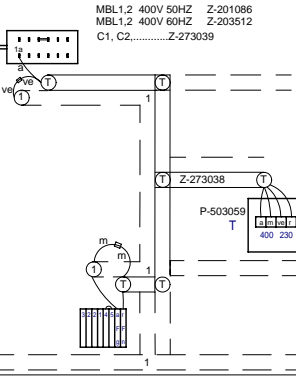

Prensaestopos R-143010  
Junta goma R-143026  
Tuerca R-143025

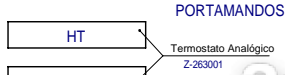

**ЗИП ОБЩЕПИТ**

# C.E

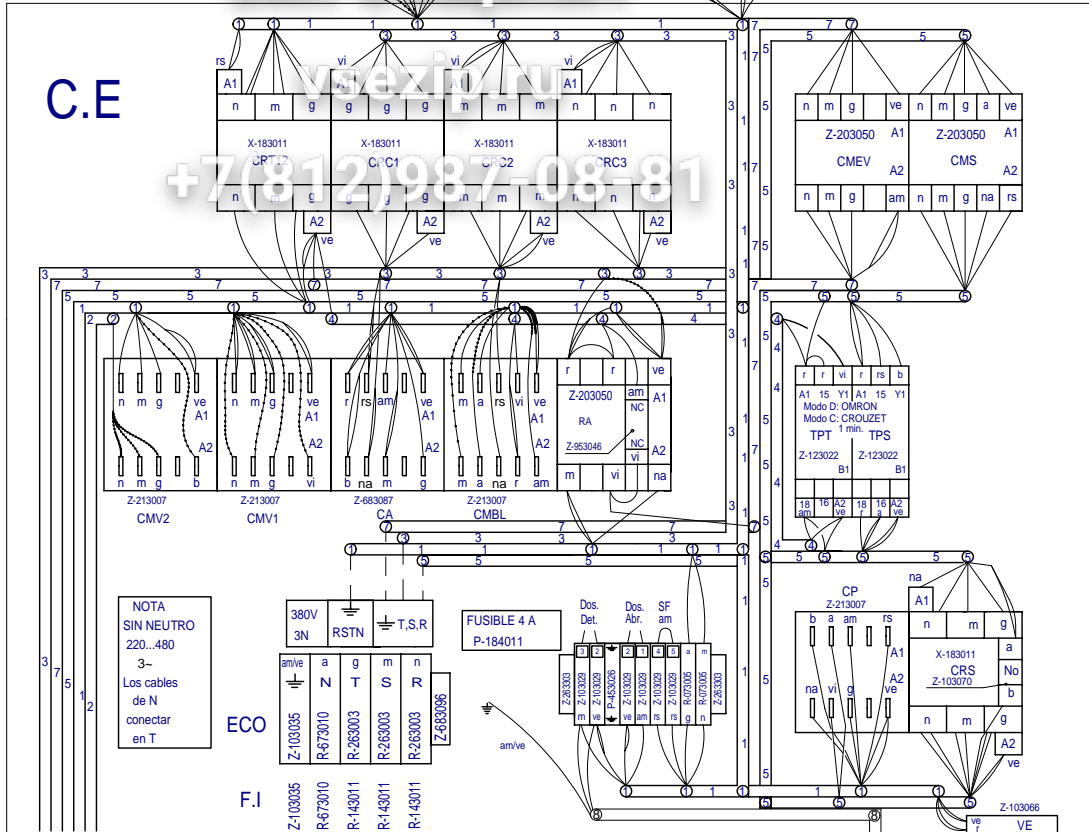

**NOTA SIN NEUTRO**  
Z20..480  
3-  
Los cables de N conectar en T

**ECO**  
Z-103035  
R-673010  
R-263003  
R-263003  
R-263003  
Z-683086

**F.I**  
Z-103035  
R-673010  
R-143011  
R-143011  
R-143011

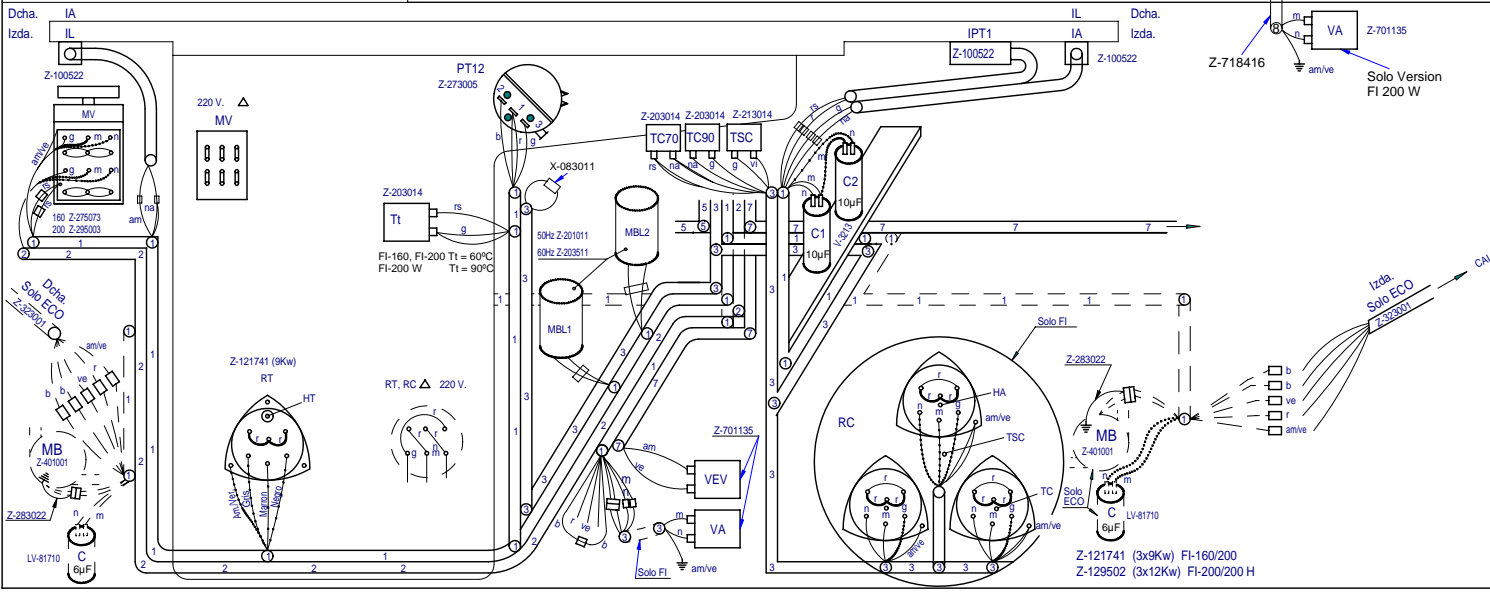

Z-121741 (3x9Kw) FI-160/200  
Z-129502 (3x12Kw) FI-200/200 H

N  
N  
C  
C  
C  
4  
5  
6  
7  
8  
9  
10  
11  
12  
13  
14  
15  
16  
17  
18  
19  
20  
21  
22  
23  
24  
25  
26  
27  
28  
29  
30  
31  
32  
33  
34  
35  
36  
37  
38  
39  
40  
41  
42  
43  
44  
45  
46  
47  
48  
49  
50  
51  
52  
53  
54  
55  
56  
57  
58  
59  
60  
61  
62  
63  
64  
65  
66  
67  
68  
69  
70  
71  
72  
73  
74  
75  
76  
77  
78  
79  
80  
81  
82  
83  
84  
85  
86  
87  
88  
89  
90  
91  
92  
93  
94  
95  
96  
97  
98  
99  
100

**ESPAÑOL**

**FRANÇAIS**

**ENGLISH**

**DEUTSCH**

**(A)(B)** = Puntos de conexión con R  
**(C)** = Puntos de conex.160/200 sin secado ni condensador  
**C1,C2** = Condensador  
**CA** = Relé auxiliar aclarado  
**CMBL 1/2/3** = Contactor bomba lavado 1/2/3  
**CMBPL** = Contactor bomba prelavado  
**CMVE** = Contactor motor extractor  
**CMS** = Contactor motor secado  
**CMV 1/2** = Contactor avance 1/2  
**CMREC** = Contactor motor recuperador  
**CRC 11/12/13/21/22** = Contactor calentamiento calderin  
**CRS** = Contactor resistencia secado  
**CRTA** = Contactor calentamiento aclarado  
**CR2T** = Contactor calentamiento tanque 2  
**CR1T1/1/2** = Contactor calentamiento tanque 1  
**CP** = Relé puerta  
**DS.ABR** = Dosificador abrillantador  
**DS.DET.** = Dosificador detergente  
**F** = Fusible  
**FMEV** = Relé termico motor extractor  
**FML1/2/3** = S. Termico bomba lavado 1/2/3  
**FMS** = Relé termico motor secado  
**FMREC** = Relé termico motor recuperador  
**FMV** = S. Termica motor avance  
**la** = Micro aclarado  
**IG** = Interruptor general  
**IL** = Micro lavado  
**Im1/2/3** = Pulsador de marcha  
**IPA** = Micro puerta aclarado  
**IP1/2/3** = Pulsador de parada  
**IPPL** = Micro puerta prelavado  
**IPT1/2/3** = Micro puerta tanque 1/2/3  
**L1** = Piloto de encendido  
**L2** = Piloto marcha  
**MB** = Bomba de llenado y aclarado  
**MBA** = Bomba aclarado  
**MBL1/2/3** = Bomba lavado 1/2/3  
**MBP** = Bomba de presion  
**MBPL** = Bomba prelavado  
**MEV** = Motor extractor vahos  
**MREC** = Motor recuperador  
**MS** = Motor secado  
**MV** = Motor avance  
**Pa** = Presostato aclarado  
**PE1/2** = Parada de emergencia  
**PPL** = Presostato prelavado  
**PT11** = Presostato lavado 1 calentamiento  
**PT12** = Presostato lavado 1 llenado  
**PT21** = Presostato lavado 2 calentamiento  
**PT2/PT22** = Presostato lavado 2 llenado  
**PT3** = Presostato lavado 3 llenado  
**R** = Relé de Generador A.C.  
**(R)(N)** = Toma de alimentacion Generador A.C.  
**Ra** = Relé auxiliar aclarado y llenado  
**RC11/12/13/21/22** = Resistencia calderin  
**RS** = Resistencia secado  
**RTA** = Resistencia calentamiento aclarado  
**RT2** = Resistencia tanque 2  
**RT11/12** = Resistencia tanque 1  
**SF** = Micro fin recorrido  
**TA** = Termostato aclarado  
**TC, 1/2** = Termostato calderin  
**TPA** = Temporizador Aclarado  
**TPT** = Temporizador inicio  
**TPS** = Temporizador secado  
**TREC** = Termostato recuperador  
**TRF** = Transformador  
**TS** = Termostato secado  
**TSC, 1/2** = Limitador calderin  
**T1/2** = Termostato tanque 1/2  
**VA** = Electrovalvula llenado y aclarado  
**VE** = Ventilador cuadro electrico  
**VEV** = Electrovalvula condensacion vahos  
**VL1/2** = Electrovalvula llenado tanque  
**VG** = Electrovalvula general  
**VREC** = Electrovalvula salida

**COLOR COLORES**  
**a** = Azul  
**am** = Amarillo  
**am/ve** = Amarillo/verde  
**b** = Blanco  
**g** = Gris  
**m** = Marrón  
**n** = Negro  
**na** = Naranja  
**r** = Rojo  
**rs** = Rosa  
**ve** = Verde  
**vi** = Violeta

**Points de connexion R**  
**Points de connexion 160/200 sans sechage ni condensateur**  
**Condensateur**  
**Relais auxillier rinçage**  
**Contacteur pompe lavage 1/2/3**  
**Contacteur pompe prelavage**  
**Contacteur moteur extracteur**  
**Contacteur moteur sechage**  
**Contacteur avance 1/2**  
**Contacteur moteur recuperateur**  
**Contacteur chauff. surchauffeur**  
**Contacteur resistances sechage**  
**Contacteur chauffage rinçage**  
**Contacteur chauffage cuve 2**  
**Contacteur chauffage cuve 1**  
**Relais porte**  
**Dosseur de tensoacif**  
**Dosseur de detergent**  
**Fusible**  
**Relais termique moteur extracteur**  
**S. Termique pompe lavage 1/2/3**  
**Relais termique moteur sechage**  
**Relais termique moteur recuperateur**  
**S. Termica motor avance**  
**Micro rinçage**  
**Interrupteur general**  
**Micro lavage**  
**Bouton marche**  
**Micro porte rinçage**  
**Bouton arrêt**  
**Micro porte prelavage**  
**Micro porte cuve 1/2/3**  
**Voyant fonctionnement**  
**Voyant demarrage**  
**Pompe remplissage rinçage**  
**Pompe rinçage**  
**Pompe lavage 1/2/3**  
**Pompe de pression**  
**Pompe prelavage**  
**Moteur extracteur vapeur**  
**Moteur recuperateur**  
**Moteur sechage**  
**Moteur avance**  
**Pressostat rinçage**  
**Arrêt d'urgence**  
**Pressostat prelavage**  
**Pressostat lavage 1 chauffage**  
**Pressostat lavage 1 remplissage**  
**Pressostat lavage 2 chauffage**  
**Pressostat lavage 2 remplissage**  
**Pressostat lavage 3 remplissage**  
**Relais du Generateur**  
**Alimentation generateur**  
**Relais auxillier rinçage remplissage**  
**Resistance surchauffeur**  
**Resistance sechage**  
**Resistance chauffage rinçage**  
**Resistance cuve 2**  
**Resistance cuve 1**  
**Micro fin de coourse**  
**Thermostat de rinçage**  
**Thermostat surchauffeur**  
**Temporisateur rinçage**  
**Temporisateur demarrage**  
**Temporisateur sechage**  
**Thermostate recuperateur**  
**Transformateur**  
**Thermostat sechage**  
**Thermostat limiteur surchauffeur**  
**Thermostat cuve 1/2**  
**Electrovanne remplissage rinçage**  
**Ventilateur tableau electricue**  
**Electrovanne condenseur vapeur**  
**Electrovanne remplissage cuve**  
**Electrovanne general**  
**Electrovanne demarrage**  
**COULEURS**  
**Bleu**  
**Jaune**  
**Jaune / vert**  
**Blanc**  
**Gris**  
**Marron**  
**Noir**  
**Orange**  
**Rouge**  
**Rose**  
**Vert**  
**Violet**

**Concection point with R**  
**Connection points 160/200 without drying nor condenser**  
**Condenser**  
**Wash pump contact. 1/2/3**  
**Pre-Wash pump contactor**  
**Exhaust motor contactor**  
**Drying motor contactor**  
**Advance contactor 1/2**  
**Water recov. on motor boiler heating contactor**  
**Drying heating element contactor**  
**Rinse heating contactor**  
**Tank heating contactor 2**  
**Tank heating contactor 1**  
**Door relay**  
**Detergent doser**  
**Fuse**  
**Thermic switch exhaust motor relay**  
**Thermic switch pump 1/2/3**  
**Drying motor thermic relay**  
**Thermic switch recover motor**  
**Thermic switch rack pulling motor**  
**Rinse microswitch**  
**Main switch**  
**Wash microswitch**  
**On pushbutton**  
**Rinse door microswitch**  
**Off pushbutton**  
**Pre-wash door microswitch**  
**Tank door microswitch 1/2/3**  
**Operation light**  
**Start light**  
**Fill and rinse pump**  
**Rinse pump**  
**Wash pump 1/2/3**  
**Pressure pump**  
**Pre-wash pump**  
**Exhaust steam motor**  
**Recover motor**  
**Drying motor**  
**Motor advance**  
**Rinse level switch**  
**Emergency stop**  
**Pre-wash level switch**  
**Wash level 1 and heating switch**  
**Wash level 1 and fill switch**  
**Wash level 2 and heating switch**  
**Wash level 2 and fill switch**  
**Wash 3 fill pressostat**  
**Generator rele**  
**Water heater feeding**  
**Rinse and fill auxiliary relay**  
**Boiler heating element**  
**Drying heating element**  
**Rinse heating heater**  
**Tank heater 2**  
**Tank heater 1**  
**Safety end switch**  
**Rinse thermostat**  
**Boiler thermostat**  
**Rinsing timer**  
**Start timer**  
**Drying timer**  
**Recover thermostat**  
**Trasformer**  
**Drying thermostat**  
**Boiler Hi-limit thermostat**  
**Tank thermostat 1/2**  
**Fill and rinse valve**  
**Switchboard fan**  
**Exhaust condenser solenoide valve**  
**Tank fill valve**  
**Main valve**  
**Outlet solenoide valve**  
**COLOUR**  
**Blue**  
**Yellow**  
**Yellow / green**  
**White**  
**Grey**  
**Brown**  
**Black**  
**Orange**  
**Red**  
**Pink**  
**Green**  
**Purple**

**Anschlusspunkte mit R**  
**Anschlusspunkte 160/200 weder ohne Trocknung noch Kondensator**  
**Kondensator**  
**Hilfsrelais Spülen**  
**Kontaktschütz Waschpumpe 1/2/3**  
**Kontaktschütz Vorwaschpumpe**  
**Kontaktschütz Abzugsmotor**  
**Kontaktschütz Trocknungsmotor**  
**Kontaktschütz Vorlauf 1/2**  
**Kontaktschütz Rekuperatormotor**  
**Kontaktschütz Boilerheizung**  
**Kontaktschütz Trocknungsheizwiderstand**  
**Kontaktschütz Spülheizung**  
**Kontaktschütz Heizung Tank 2**  
**Kontaktschütz Heizung Tank 1**  
**Türrelais**  
**Dosierer Glanzmittel**  
**Dosierer Spülmittel**  
**Sicherung**  
**Thermorelais Abzugsmotor**  
**Thermoschalter Waschpumpe 1/2/3**  
**Thermorelais Trocknungsmotor**  
**Thermorelais Rekuperatormotor**  
**Thermoschalter Vorlaufmotor**  
**Mikroschalter Spülen**  
**Hauptschalter**  
**Mikroschalter Waschen**  
**Betriebstaster**  
**Mikroschalter Tür Spülen**  
**Aus-Taster**  
**Mikroschalter Tür Vorwaschen**  
**Mikroschalter Tür Tank 1/2/3**  
**Betriebsanzeigelampe**  
**Startanzeigelampe**  
**Füll-und Spülpumpe**  
**Spülpumpe**  
**Waschpumpe 1/2/3**  
**Druckpumpe**  
**Vorwaschpumpe**  
**Motor Dampfabzug**  
**Rekuperatormotor**  
**Trocknungsmotor**  
**Vorlaufmotor**  
**Druckregler Spülen**  
**Not-Aus**  
**Druckregler Vorwaschen**  
**Druckregler Waschstufe 1 Heizen**  
**Druckregler Waschstufe 1 Füllen**  
**Druckregler Waschstufe 2 Heizen**  
**Druckregler Waschstufe 2 Füllen**  
**Druckwächter Spülgang 3 Füllvorgang**  
**Relais Generator**  
**Stromversorgungsanschluss Generator**  
**Hilfsrelais Spülen und Füllen**  
**Boilerheizwiderstand**  
**Heizwiderstand Trocknen**  
**Heizwiderstand Spülen**  
**Heizwiderstand Tank 2**  
**Heizwiderstand Tank 1**  
**Mikroschalter Zyklusende**  
**Thermostat zum Spülen**  
**Thermostat kessel**  
**Zeitschaltuhr Spülgang**  
**Start-Timer**  
**Trocknungs-Timer**  
**Rekuperator-Timer**  
**Transformator**  
**Trocknungsthermostat**  
**Grenzthermostat Boiler**  
**Thermostat Tank 1/2**  
**Elektroventil Füllen und Spülen**  
**Schalttafelventilator**  
**Elektroventil Dampfkondensation**  
**Elektroventil Tankfüllung**  
**Hauptelektroventil**  
**Ausgangselectroventil**  
**FARBEN**  
**Blau**  
**Gelb**  
**Gelb/grün**  
**Weiß**  
**Grau**  
**Braun**  
**Schwarz**  
**Orange**  
**Rot**  
**Rosa**  
**Grün**  
**Violett**

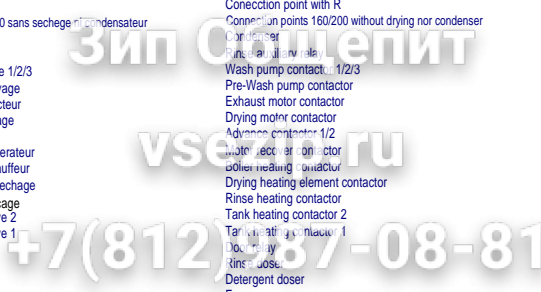

Leyenda Lavavajillas HC-17259-3 Z313070000

