

Зип Общепит

vsezip.ru

DESPIECE TECNICO

+7(812)987-08-81

Lavadoras de centrifugado estándar
Laveuses à essorage standard
Washing machines
Washmaschinen
Lavatrici

LAVANDERIA

Modelos:

LC/E-25 // LC/AC-25 // LC/V-25

Mayo 2002 May



Зип Общепит

vsezip.ru

+7(812)987-08-81

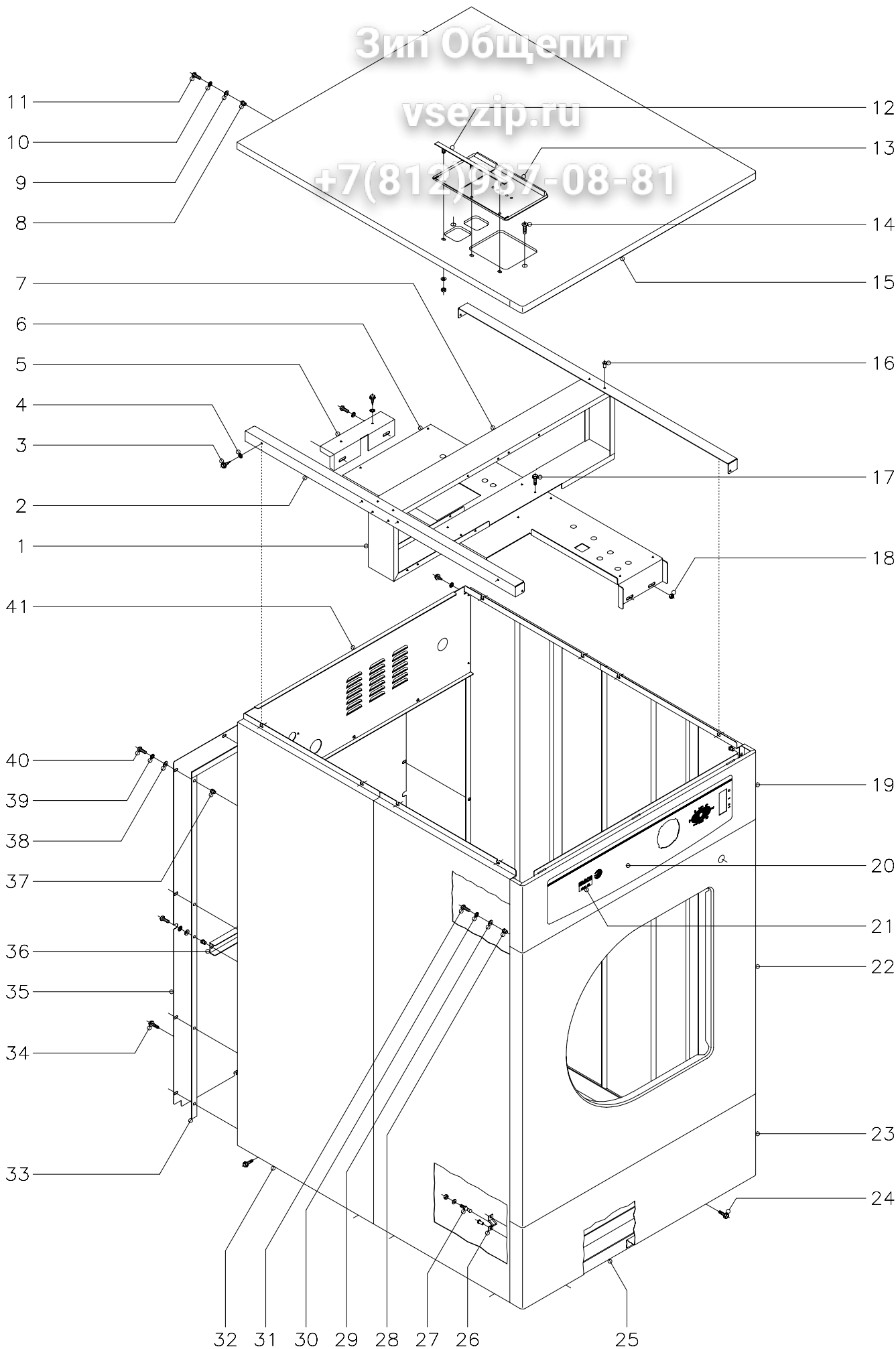

N plano

C-1162

Firma

Fecha

5-2002

Aparato

ARMAZON Y MUEBLE
LAVADORAS LC-25

Lamina

1

Fagor Industrial S.Coop. **FAGOR**

Onate

MOD.		LAVADORAS LC	ZONA	ARMAZON Y MUEBLE				
ITEM	CODIGO	DENOMINACION	TEXTO	LC-25				
1	P460301	Sujecion cuadro electrico		1				
2	P530319	Sujecion panel lateral		2				
3	Q151335	Tornillo c/ arandela A-5,6x13		10				
4	Q242040	Arandela abanico A-6		10				
5	P533005	Soporte base cuadros		1				
	Q012031	Tornillo exagonal M-5x10		2				
	Q242030	Arandela abanico A-5		2				
	Q151335	Tornillo c/ arandela A-5,6x13		2				
	Q242040	Arandela abanico A-6		2				
6	P533004	Base de cuadro electrico		1				
7	P530312	Liston superior		1				
8	Q221342	Remache exagonal M-5		2				
9	Q302022	Arandela plana Ø16xØ6x1,2		2				
10	Q242030	Arandela abanico A-5		2				
11	Q012031	Tornillo exagonal M-5x10		2				
12	P440705	Soporte tapa cubeta		1				
	Q232030	Arandela plana A-5		3				
	Q162030	Tuerca exagonal M-5		3				
13	P440704	Tapa cubeta		1				
14	Q042022	Tornillo avellanado M-5x15		2				
15	P530318	Encimera		1				
16	Q419005	Remache tubular Ø4x8		12				
17	Q151323	Tornillo broca Ø4,8x16		4				
18	Q222012	Tuerca exagonal autoblocante M-6		2				
19	P530303	Portamandos		1				
20	P530304	Embellecedor portamandos		1				
21	P466501	Adhesivo modelo LC/E-25		1				
21	P466502	Adhesivo modelo LC/AC-25		1				
21	P466503	Adhesivo modelo LC/ V-25		1				

Зип Общепит

vsezip.ru

+7(812)987-08-81

MOD.		LAVADORAS LC	ZONA	ARMAZON Y MUEBLE				
ITEM	CODIGO	DENOMINACION	TEXTO	LC-25				
21	P466504	Adhesivo modelo LC/E-25, 60 Hz.		1				
21	P466505	Adhesivo mod. LC/E-25,60 Hz.S./N.		1				
21	P466506	Adhesivo modelo LC/E-25, S.N.		1				
22	P530325	Panel frontal		1				
23	P530310	Suplemento panel frontal		1				
24	Q151323	Tornillo broca Ø4,8x16		10				
25	P530101	Armazon completo		1				
26	X010503	Muelle enganche piton		2				
	Q419007	Remache tubular Ø3,2x6		4				
27	P450303	Piton enganche		2				
	Q232030	Arandela plana A-5		2				
	Q221308	Tuerca exagonal autoblocante M-5		2				
28	Q221342	Remache exagonal M-5		8				
29	Q302022	Arandela plana Ø16xØ6x1,2		8				
30	Q242030	Arandela abanico A-5		8				
31	Q012031	Tornillo exagonal M-5x10		8				
32	P530329	Panel lateral completo		4				
33	3714500	Perfil esponj. adhesivo 20x2x5000		1				
34	Q151323	Tornillo broca Ø4,8x16		2				
35	P530316	Panel posterior		1				
36	P530333	Sujecion panel posterior		1				
37	Q221342	Remache exagonal M-5		15				
38	Q302022	Arandela plana Ø16xØ6x1,2		15				
39	Q242030	Arandela abanico A-5		15				
40	Q012031	Tornillo exagonal M-5x10		15				
41	P530315	Soporte electrovalvulas		1				
	Q242040	Arandela abanico A-6		14				
	Q151335	Tornillo c/arandela A-5,6x13		14				

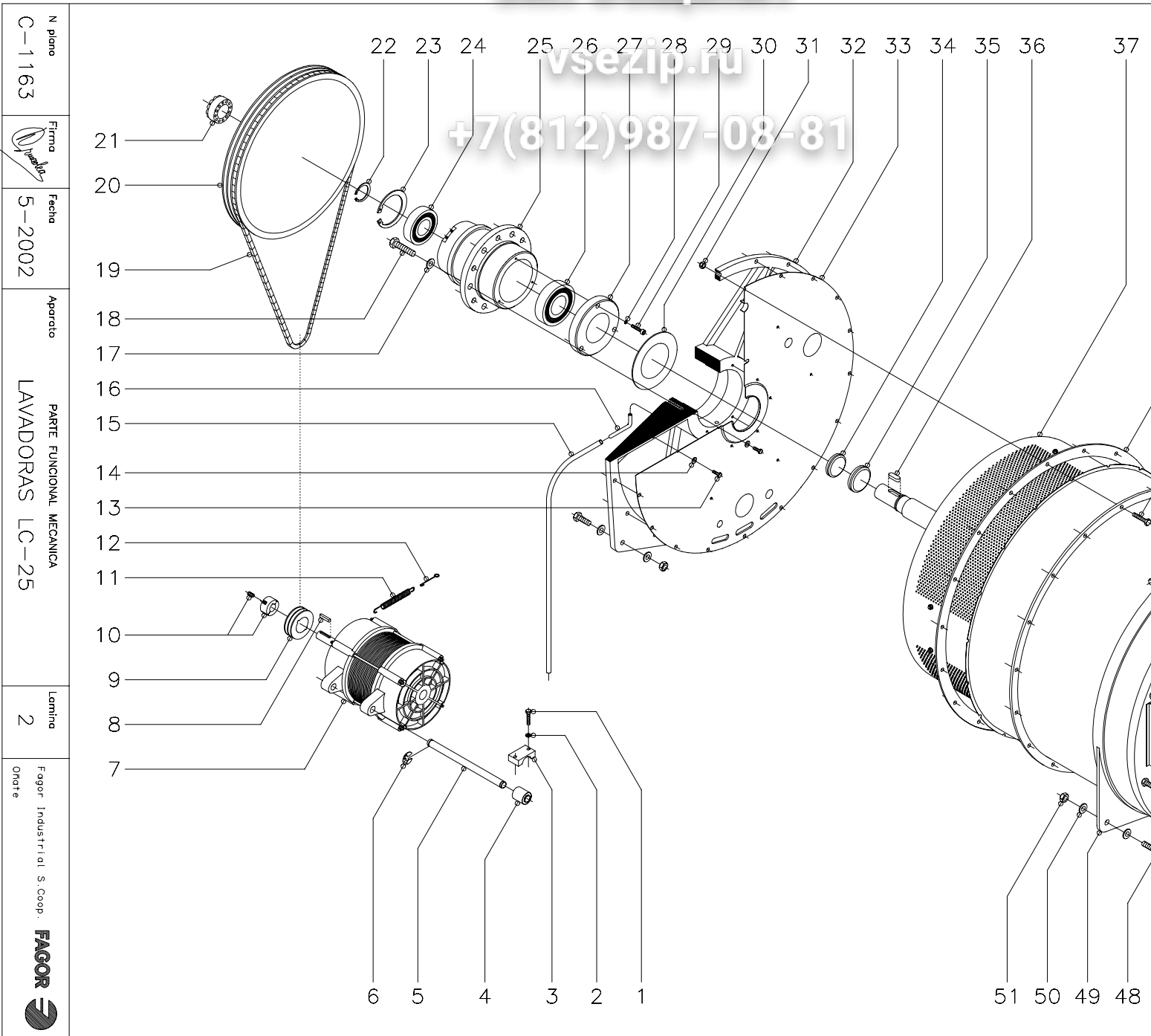

N plano
C-1163

Firma



Fecha
5-2002

Aparato

PARTE FUNCIONAL MECANICA
LAVADORAS LC-25

Lamina
2

Orate

Fagor Industrial S. Coop.

Зип Общепит

vsezip.ru

+7(812)987-08-81

MOD.		LAVADORAS LC	ZONA	PARTE FUNCIONAL MECANICA				
ITEM	CODIGO	DENOMINACION	TEXTO	LC-25				
1	Q012056	Tornillo exagonal M-8x40		4				
2	Q242050	Arandela abanico A-8		4				
3	P535909	Amarre superior amortiguacion		2				
4	P535910	Amortiguador motor		2				
5	P535901	Eje soporte motor		1				
6	Q271027	Arandela de seguridad Ø 15		2				
7	P535904	Motor 230/400 V. 50 Hz.		1				
8	P535912	Lengüeta motor 8x7x40		1				
9	P435903	Polea motor 50 Hz.		1				
10	P455904	Casquillo polea con tornillos		1				
11	P445912	Resorte tensor de motor		2				
12	P445915	Alargadera resorte tensor		2				
13	Q012042	Tornillo exagonal M-6x15		12				
14	Q304040	Arandela estanquei. Ø10,4xØ6,4x1		12				
15	3721900	Tubo transparente Ø14xØ10x800		1				
16	P536016	Tubo evacuacion		1				
17	Q301302	Arandela plana A-17		6				
18	Q011399	Tornillo exagonal M-16x70		6				
19	P535903	Correa SPZ LW 2360		2				
20	P536003	Polea tambor		1				
21	P536017	Buje amarre polea tambor		1				
22	Q301041	Anillo de seguridad en eje Ø50		1				
23	Q301036	Anillo de seguridad J-110x4		1				
24	P536005	Rodamiento 6310-2Z		1				
25	P536002	Soporte rodamientos		1				
26	P536004	Rodamiento 6312-2RS		1				
27	P536008	Contrareten		1				
28	Q262040	Arandela grower A-6		3				
29	Q052046	Tornillo allem M-6x40		3				

MOD.		LAVADORAS LC		ZONA	PARTE FUNCIONAL MECANICA			
ITEM	CODIGO	DENOMINACION	TEXTO	LC-25				
30	P536014	Junta contrareten		1				
31	Q221306	Tuerca autoblocante M-10		18				
32	P536001	Soporte fondo cuba		1				
33	P536010	Fondo cuba		1				
34	P534914	Reten V-RING - 65 S		1				
35	P534915	Reten V-RING - 75 S		1				
36	P536015	Lengüeta eje tambor A.14x9x40		1				
37	P464907	Tambor completo		1				
38	P536106	Junta de cuba		1				
39	Q151326	Tornillo exagonal M-10x55		18				
40	Q151326	Tornillo exagonal M-10x55		1				
41	Q221306	Tuerca autoblocante M-10		1				
42	P466101	Cuba completa		1				
43	P530505	Soporte bisagra		2				
44	Q222012	Tuerca autoblocante M-6		8				
45	P530365	Fondo puerta		1				
46	Q032031	Tornillo alomado M-5x10		4				
47	3673700	Perfil goma gris "U" 12x6x1360		1				
48	Q011387	Tornillo exagonal M-14x50		4				
49	P536107	Anillo anterior soporte cuba		1				
50	Q301380	Arandela plana A-15		8				
51	Q221338	Tuerca autoblocante M-14		4				

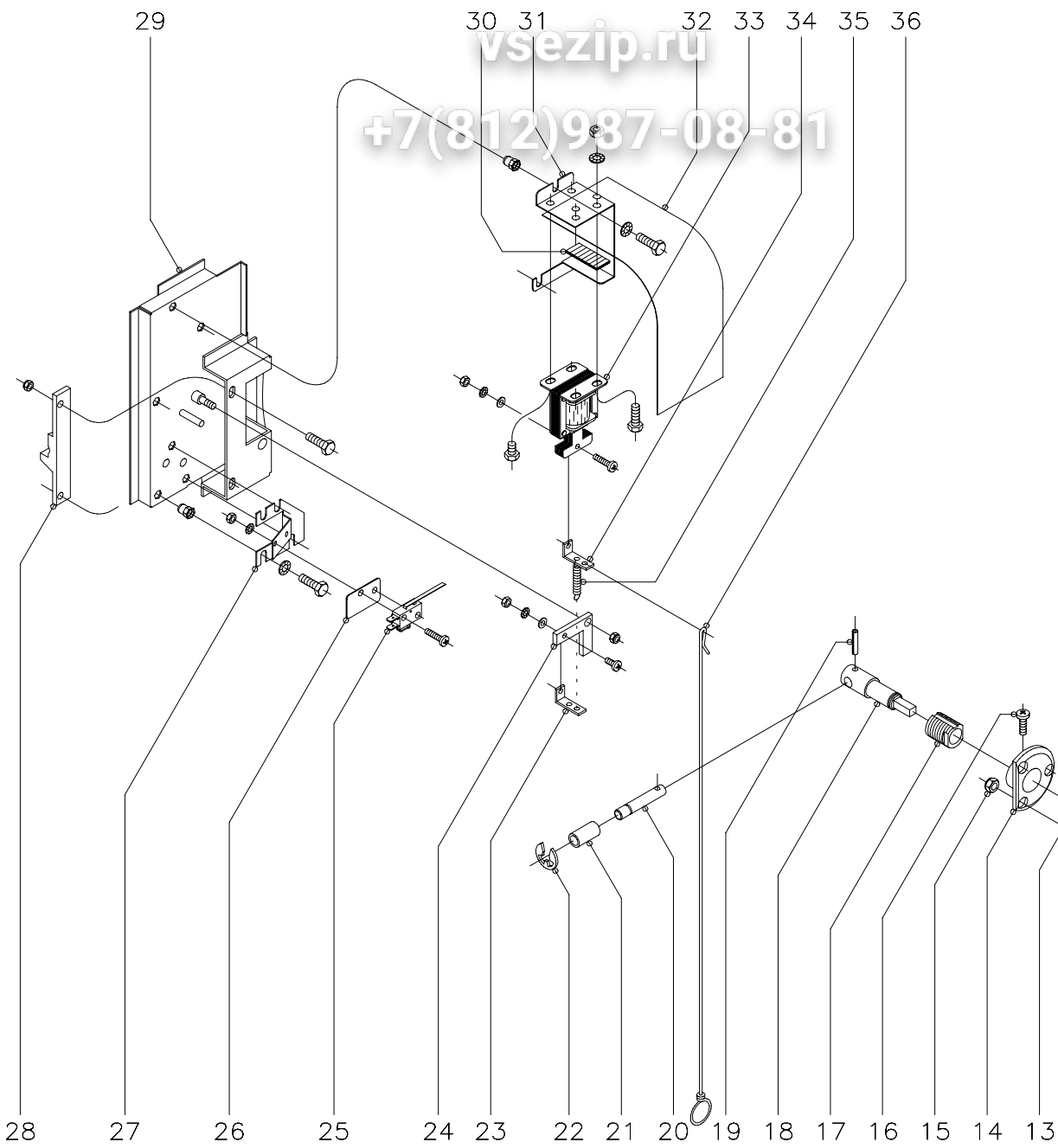

N plano C-1164	Firma 	Fecha 5-2002	Apartado PUERTA LAVADORAS LC-25	Laminia 3	Fagor Industrial S.Coop. Onate
-------------------	-----------	-----------------	---------------------------------------	--------------	-----------------------------------



Зип Общепит

vsezip.ru

+7(812)987-08-81

MOD.		LAVADORAS LC	ZONA	PUERTA				
ITEM	CODIGO	DENOMINACION	TEXTO	LC-25				
1	Q222030	Tuerca autoblocante M-5		4				
2	Q222012	Tuerca autoblocante M-6		4				
3	P500504	Sujecion bisagra		2				
4	P500502	Bisagra puerta		2				
5	P530505	Soporte bisagra		2				
6	Q222012	Tuerca autoblocante M-6		8				
7	Q062035	Tornillo allem 3 avellanado M-5x30		4				
8	P530550	Marco puerta		1				
9	P530502	Junta de puerta		1				
10	P530503	Mirilla puerta		1				
11	Q132042	Varilla roscada M-6x15		1				
12	P530538	Manilla puerta		1				
13	Q271034	Anillo seguridad A-12		1				
14	P530557	Soporte cojinete		1				
15	Q222012	Tuerca autoblocante M-6		3				
16	Q152015	Tornillo alomado M-3x6		1				
17	P530545	Cojinete guia		1				
18	P530543	Eje manilla		1				
19	Q371031	Manguito sujecion Ø3x20		1				
20	P530542	Eje tope		1				
21	P530544	Casquillo cierre		1				
22	Q301043	Anillo seguridad A-10		1				
23	P530559	Empalme muelle		1				
	Q032011	Tornillo alomado M-3x10		1				
	Q231310	Arandela plana A-3		1				
	Q242010	Arandela abanico A-3		1				
	Q161310	Tuerca exagonal M-3		1				
24	P530514	Tope cierre		1				
	Q222012	Tuerca autoblocante M-6		1				

MOD.		LAVADORAS LC	ZONA	PUERTA				
ITEM	CODIGO	DENOMINACION	TEXTO	LC-25				
25	P530558	Microrruptor puerta		1				
	Q032013	Tornillo alomado M-3x20		2				
	Q242010	Arandela abanico A-3		2				
	Q161310	Tuerca exagonal M-3		2				
26	R010535	Placa separadora		1				
27	P530541	Soporte micro		1				
	Q012033	Tornillo exagonal M-5x20		3				
	Q242030	Arandela abanico A-5		3				
28	P530549	Pestillo		1				
	Q012042	Tornillo exagonal M-6x15		2				
	Q222012	Tuerca autoblocante M-6		2				
29	-	Sujecion cierre (Soldado a cuba)		-				
30	3714500	Perfil esponjoso adhesivo 20x2x40		1				
31	P530525	Sujecion electroiman		1				
	Q012033	Tornillo exagonal M-5x20		3				
	Q242030	Arandela abanico A-5		3				
32	P530540	Cubierta electroiman		1				
33	P533046	Electroiman de puerta		1				
	Q012021	Tornillo exagonal M-4x10		4				
	Q242020	Arandela abanico A-4		4				
	Q162020	Tuerca exagonal M-4		4				
34	P530559	Empalme muelle		1				
	Q032011	Tornillo alomado M-3x20		1				
	Q231310	Arandela plana A-3		1				
	Q242010	Arandela abanico A-3		1				
	Q161310	Tuerca exagonal M-3		1				
35	P530531	Muelle electroiman		1				
36	P530507	Palanca apertura manual		1				

Зип Общепит

vsezip.ru

+7(812)987-08-81

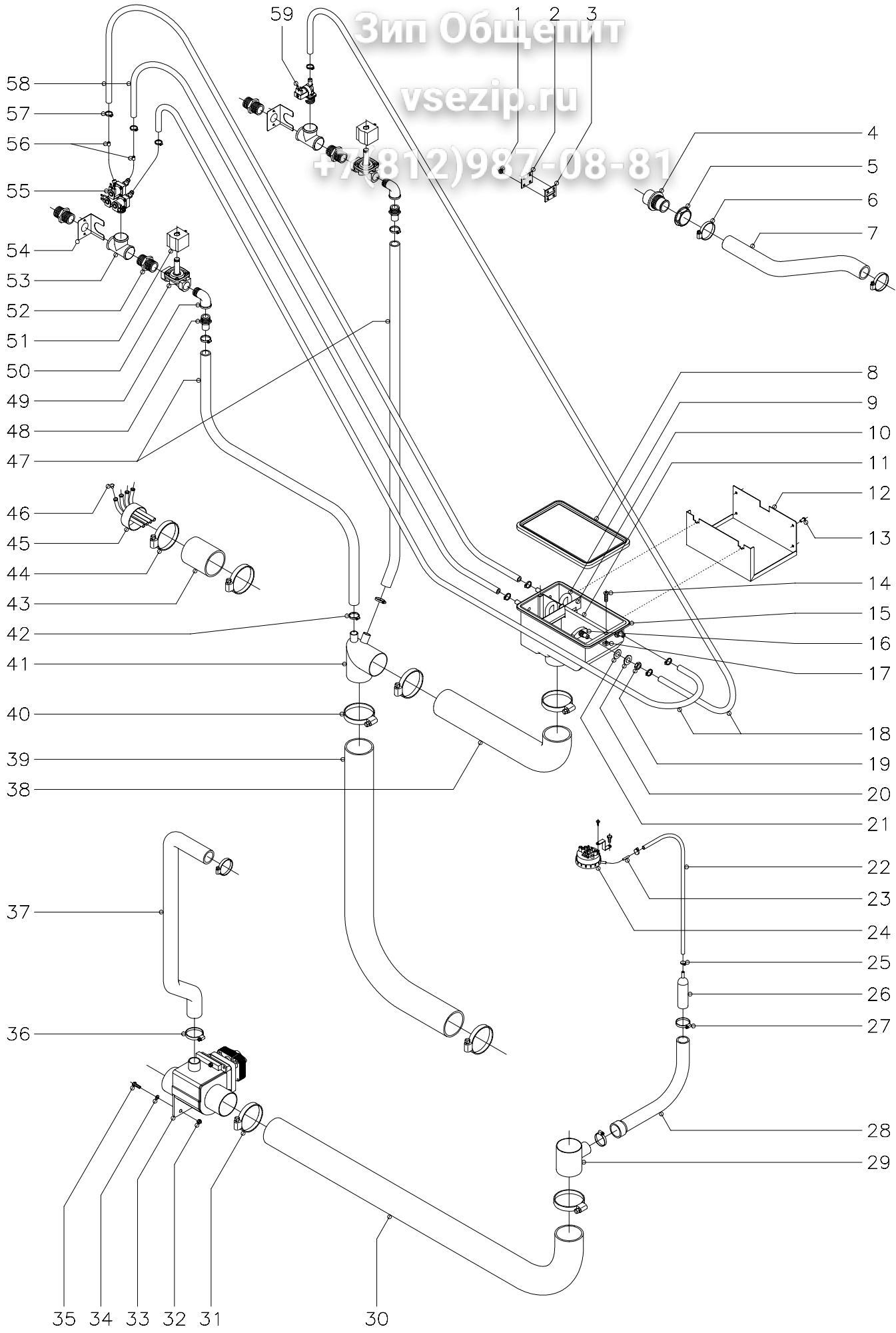

N plano C-1165	Firma <i>[Signature]</i>	Fecha 5-2002	Aparato PARTE FUNCIONAL HIDRAULICA LAVADORAS LC-25	Lamina 4	Fagor Industrial S.Coop. FAGOR  Onate
-------------------	-----------------------------	-----------------	--	-------------	--

Зип Общепит

vsezip.ru

+7(812)987-08-81

MOD.		LAVADORAS LC	ZONA	PARTE FUNCIONAL HIDRAULICA				
ITEM	CODIGO	DENOMINACION	TEXTO	LC-25				
1	Q222012	Tuerca exagonal autoblocante M-6		4				
2	P435001	Tapa junta		1				
3	P505003	Junta inyector		1				
4	Z740701	Pasamuros		1				
5	Z710708	Tuerca pasamuros		1				
6	Q881306	Abrazadera 32-50		2				
7	P532102	Conducto salida vapores		1				
8	P500702	Junta de cubeta		1				
9	P440702	Tubo sifon		2				
10	P440715	Escuadra proteccion		1				
11	P440721	Perfil refuerzo		1				
12	P460701	Sujecion cubetera		1				
13	Q419000	Remache tubular Ø4x8		4				
14	Q042022	Tornillo avellanado M-4x15		2				
15	P440700	Cubeta de detergentes		1				
16	P440701	Difusor de detergentes		2				
17	Q222004	Tuerca cuadrada M-4		2				
18	3676900	Tubo goma negra Ø17xØ10x1300		2				
19	Q223018	Tuerca exagonal M-16x1,5		2				
20	Q301302	Arandela plana A-17		2				
21	Q307002	Arandela junta Ø28xØ15x1		2				
22	3702400	Tubo goma negra Ø8xØ4x2000		1				
23	P533034	Amortiguador presostato		1				
24	P533002	Presostato de nivel		1				
	Q082032	Tornillo alomado BZ-3,5x9,5		1				
	P503068	Soporte presostato		1				
	Q032031	Tornillo alomado M-5x10		1				
25	Z704061	Brida cremallera		2				
26	P445002	Camara presostato		1				

MOD.	LAVADORAS LC		ZONA	PARTE FUNCIONAL HIDRAULICA				
ITEM	CODIGO	DENOMINACION	TEXTO	LC-25				
27	Q881306	Abrazadera 32-50		2				
28	P445001	Codo de presostato		1				
29	-	Toma presion		1				
30	P532101	Conducto a valvula vaciado		1				
31	Q881326	Abrazadera 70-90		2				
32	Q162030	Tuerca exagonal M-5		2				
33	P532103	Valvula de vaciado		1				
34	Q242040	Arandela abanico A-6		2				
35	Q012032	Tornillo exagonal M-5x15		2				
36	Q881306	Abrazadera 32-50		2				
37	P532102	Conducto rebosadero		1				
38	P540701	Conducto cubeta a codo		1				
39	P532109	Conducto de llenado codo a cuba		1				
40	Q881326	Abrazadera 70-90		4				
41	P530799	Codo entrada agua		1				
42	Q881304	Abrazadera 20-32		4				
43	P532108	Tubo tapon empalme dosificadores		1				
44	Q881326	Abrazadera 70-90		2				
45	P532111	Empalme dosificadores		1				
46	P532116	Tapon empalme dosificadores		4				
47	3714800	Tubo goma negra Ø26xØ19x200		2				
48	P533009	Empalme 3/4"		2				
49	Z718421	Codo M-H 3/4"		2				
50	Z102305	Electrovalvula 3/4"		2				
51	Z102323	Bobina de electrovalvula 240 V.		2				
52	Z102301	Manguito 3/4"		4				
53	Z102303	Te a 90° de 3/4"		2				
54	P535003	Tope electrovalvula		2				
55	Z611123	Electrovalvula triple		1				

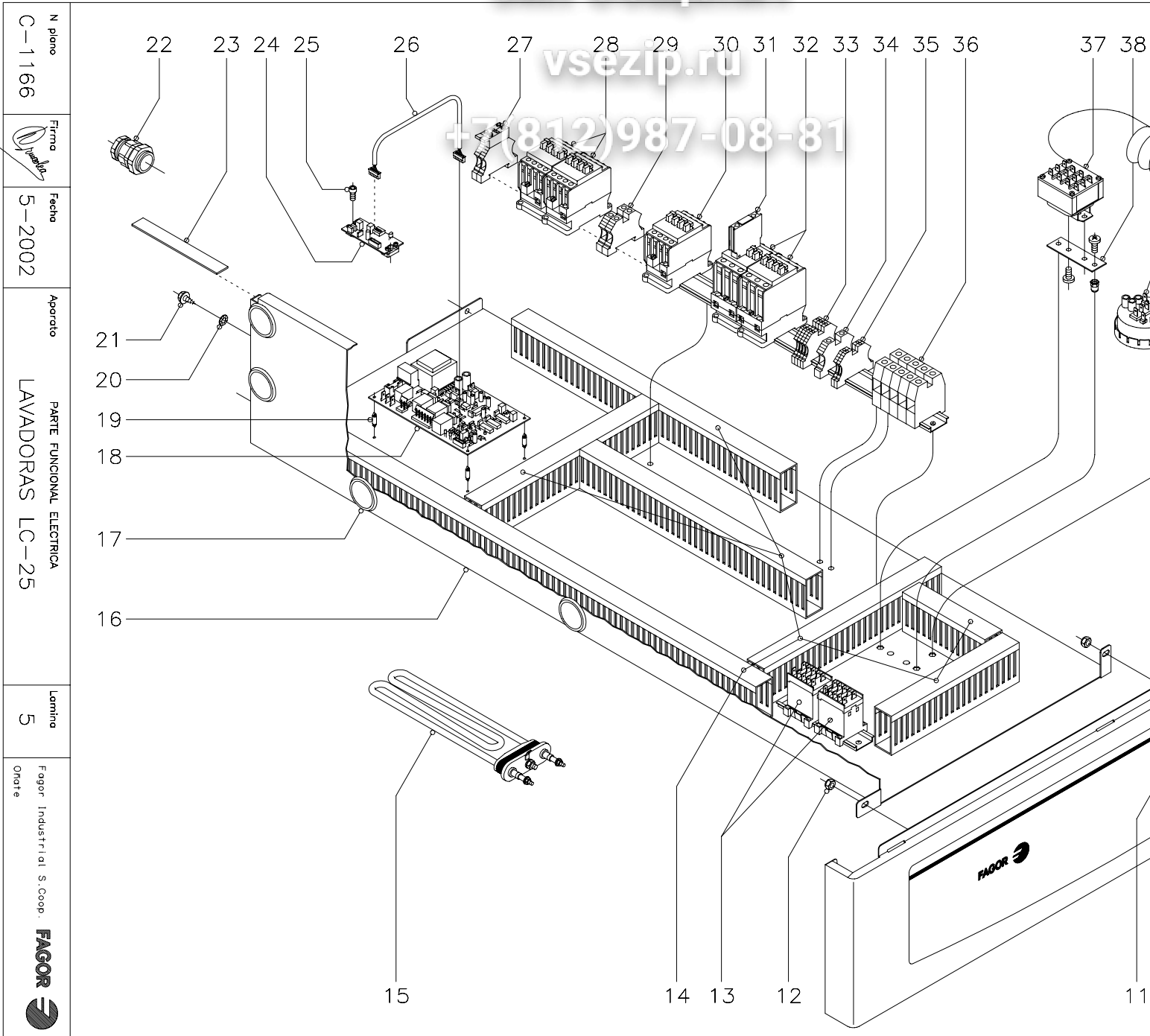

N plano
C-1166

Firma
Industria

Fecha
5-2002

Aparto
PARTE FUNCIONAL ELECTRICA
LAVADORAS LC-25

Lamina
5

Fagor Industrial S. Coop.
Orate
FAGOR

Зип Общепит

vsezip.ru

+7(812)987-08-81

MOD.		LAVADORAS LC	ZONA	PARTE FUNCIONAL ELECTRICA				
ITEM	CODIGO	DENOMINACION	TEXTO	LC-25				
1	P530303	Portamandos		1				
2	P503004	Piloto rojo		1				
3	P503005	Pulsador verde (puerta)		1				
4	P503006	Pulsador blanco (avance)		1				
5	R663062	Boton de mando completo		1				
6	P440336	Marco mirilla		1				
7	P302882	Embellecedor disco programador		1				
8	P500315	Mirilla de disco		1				
9	P500314	Disco programador		1				
10	P433023	Conmutador 8 posiciones		1				
	Z602906	Casquillo distanciador		2				
	Q041324	Tornillo avellanado M-4x25		2				
11	P433004	Programador rotativo		1				
	Q151320	Tornillo alomado M-4x6		2				
	Q242020	Arandela abanico A-4		2				
12	Q222012	Tuerca exagonal autoblocante M-6		3				
13	Z683087	Contactador 230 V.		2				
	Z103084	Guia contactor L=138		1				
14	3715520	Canaleta unex 60x30xlongitud		7				
	Q419005	Remache tubular Ø4x8		20				
15	P533001	Resistencia 6000 W. 230 V.		3				
16	P463006	Cuadro electrico		1				
17	X723014	Pasamuros Ø30		4				
18	P463001	Circuito seguridad bajas revolucio.		1				
19	P503043	Separador		4				
20	Q242040	Arandela abanico A-6		4				
21	Q151335	Tornillo c/arandela A-5,6x13		4				
22	R033002	Prensaestopas		1				
23	3714500	Perfil esponjoso adhe.20x2x1000		1				

Зип Общепит

vsezip.ru

+7(812)987-08-81

MOD.		LAVADORAS LC	ZONA	PARTE FUNCIONAL ELECTRICA				
ITEM	CODIGO	DENOMINACION	TEXTO	LC-25				
24	P533016	Sensor galga liar		1				
25	Q122032	Tornillo allem M-5x15		2				
26	P503028	Cableado sensor		1				
27	R073005	Borna portafusibles		2				
	P184011	Cartucho fusible 4 A.		2				
28	P433030	Contactador 3TF3001-OAL2 (230V.)		2				
29	P453025	Borne paso 10 (gris)		2				
30	P433030	Contactador 3TF3001-OAL2 (230V.)		1				
31	P443080	Contacto auxiliar 3RH1921-1CAO1		1				
32	X183011	Contactador 3RT1024-1AN20 (230V.)		2				
33	Z103029	Borne paso 2,5 (gris)		4				
34	P453026	Borne tierra 10 (amarillo-verde)		1				
35	Z103029	Borne paso 2,5 (gris)		2				
36	R263003	Borne paso 35 (gris)		3				
	R673010	Borne neutro 35 (azul)		1				
	Z103035	Borne tierra 35 (amarillo-verde)		1				
	Z103083	Guia contactador L= 73		1				
	R663054	Guia contactador L= 320		1				
37	P433018	Termostato 4 tempera. Preselecci.		1				
	Q032021	Tornillo alomado M-4x10		2				
38	P453020	Sujecion termostato		1				
	Q032031	Tornillo alomado M-5x10		2				
	Q221342	Remache exagonal M-5		2				
39	P533002	Presostato de nivel		1				
	Q082032	Tornillo alomado BZ-3,5x9,5		1				
40	P503068	Soporte presostato		1				
	Q032031	Tornillo alomado M-5x10		1				
41	P443060	Tapon		1				
42	N503017	Soporte termostato		1				

Зип Общежит

vsezip.ru

+7(812)987-08-81

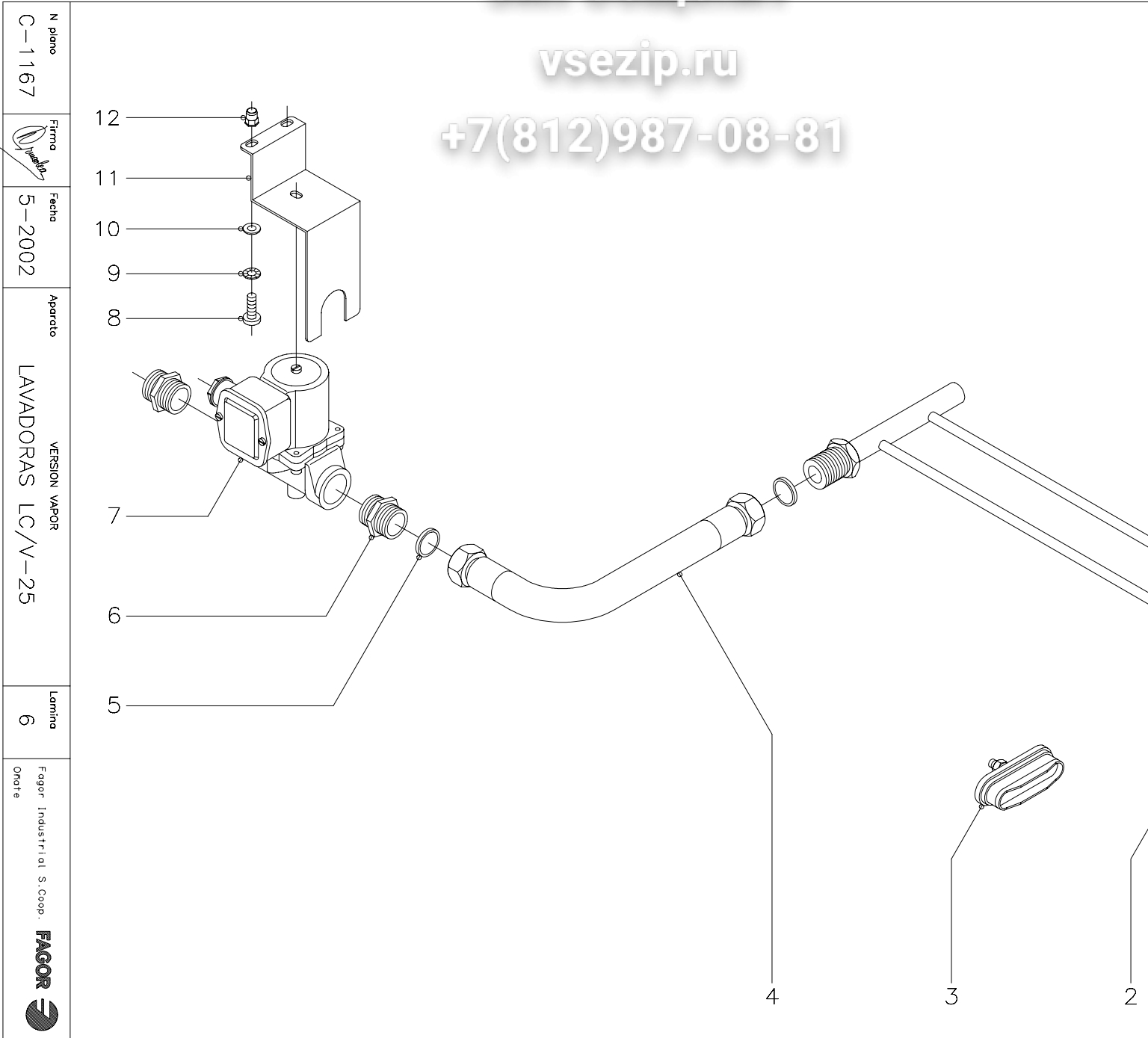

N plano
C-1167

Firma
FAGOR

Fecha
5-2002

Aparato
VERSION VAPOR
LAVADORAS LC/V-25

Lamina
6

Fagor Industrial S. Coop.
FAGOR

MOD.	LAVADORAS LC		ZONA	VERSION VAPOR				
ITEM	CODIGO	DENOMINACION	TEXTO	LC/ E-25	LC/ V-25			
		SE ELIMINAN						
	P533001	Resistencia 6000 W., 230 V.		3	-			
	P533059	Cableado a resistencias		1	-			
	X183011	Contactador 3RT1024-1AN20, 230 V.		1	-			
	P533026	Cableado regletas a contactores		1	-			
		SE INTRODUCEN						
1	P445011	Cierre completo		-	1			
2	P535013	Inyector de vapor		-	1			
3	P505008	Tapon cierre completo		-	2			
4	P545011	Latiguillo de vapor L=600		-	1			
5	-	Arandela junta (con latiguillo)		-	2			
6	Z102301	Manguito doble 3/4"		-	2			
7	P535011	Electrovalvula vapor 3/4" (50 Hz.)		-	1			
7	P535021	Electrovalvula vapor 3/4" (60 Hz.)		-	1			
8	Q032031	Tornillo alomado M-5x10		-	2			
9	Q242030	Arandela abanico A-5		-	2			
10	Q302022	Arandela plana Ø16xØ6x1,2		-	2			
11	P535004	Soporte electrovalvula vapor		-	1			
12	Q221342	Remache exagonal M-5		-	2			
s/n	P535019	Manguera de vapor L=1500mm.		-	1			
s/n	U307031	Arandela junta Ø24xØ15x3		-	2			
s/n	P533054	Cableado electrovalvula vapor		-	1			

