

Вип Общегит

vsezip.ru

+7(812)987-08-81

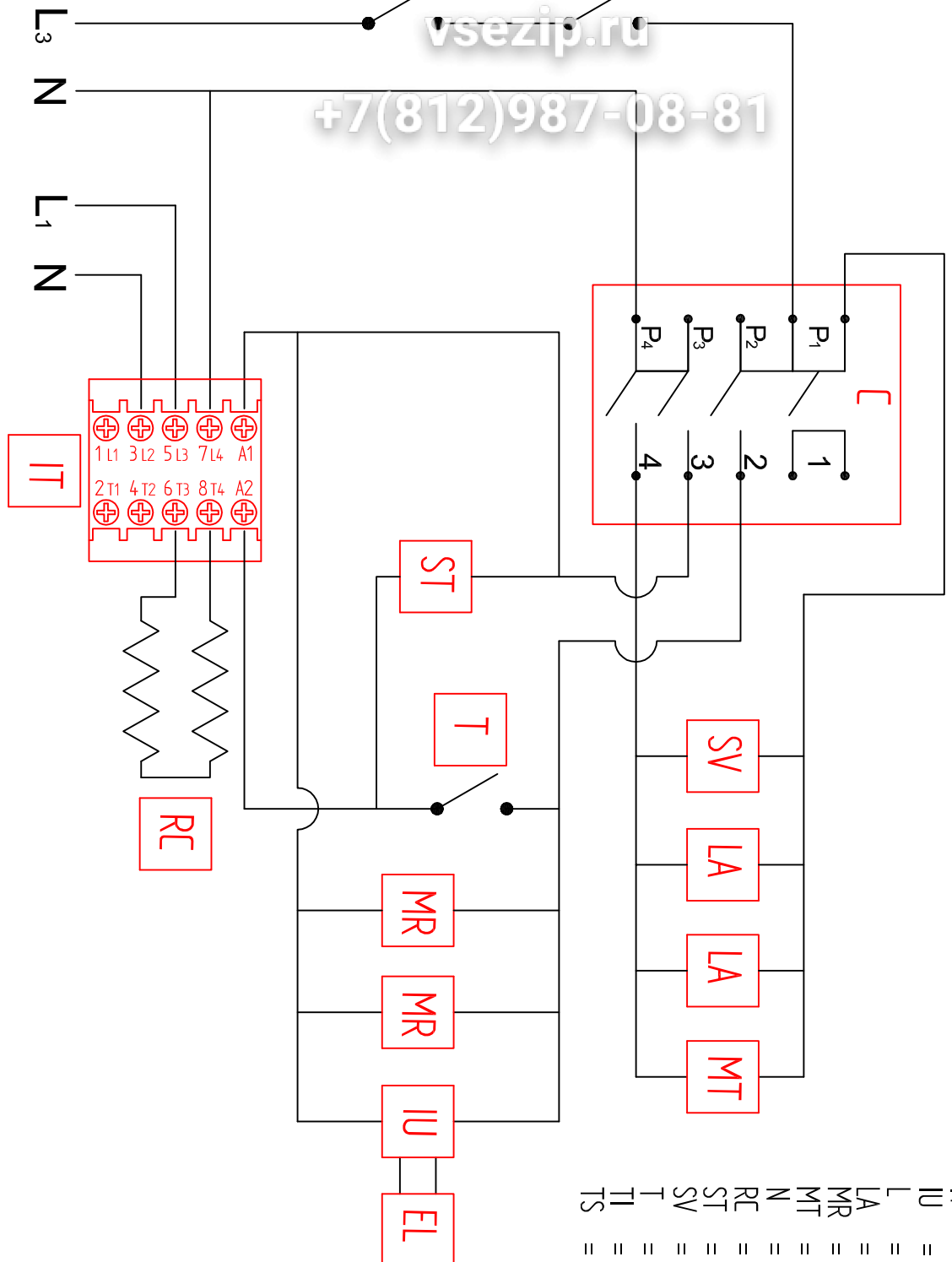

- C = SELECTOR
- EL = ELECTRIC VALVE FOR HUMIDIFIER
- IT = CONTACTORS
- IU = HUMIDITY CONTROL
- L = ALIMENTATION (line/fase)
- LA = OVEN LAMPS
- MR = MOTOR
- MT = COOLING FAN
- N = ALIMENTATION (neutral)
- RC = HEATING ELEMENTS
- ST = RED LIGHT ON/OFF THERMOSTAT
- SV = GREEN LIGHT ON/OFF THERMOSTAT
- T = OVEN THERMOSTAT
- TI = TIMER
- TS = SECURITY THERMOSTAT

4	TOLLERANZE: UNI 5307	SCALA	PIRON	DENOMINAZIONE ELECTRICAL SCHEME	MODELLO OVEN 800, 800U	DISEGNATO: Conte R.
3	da 1 a 6 ±0,08	DATA				
2	da 6 a 18 ±0,12	19/04/2010				
1	da 18 a 50 ±0,18					
RELEASE	MODIFICHE	FIRMA	da 50 a 80 ±0,23		TRATTAMENTO	FILE	VERIFICATO	
			da 80 a 120 ±0,27					
			da 120 a 250 ±0,33					
			da 250 a 400 ±0,42					
			da 400 a oltre ±0,50					