

Зип Общепит

DESPIECE TECNICO

vsezip.ru

+7(812)987-08-81

Lavavajillas
Lavevaisselle
Dishwasher
Geschirrspüler
Lavastoviglie

Modelos:

AD-48

AD-48 B

AD-48 C

AD-48 D

AD-48 DD

Diciembre 2009 December



Fagor Industrial

Зит Общепит

всезр.ш

+7(812)987-08-87

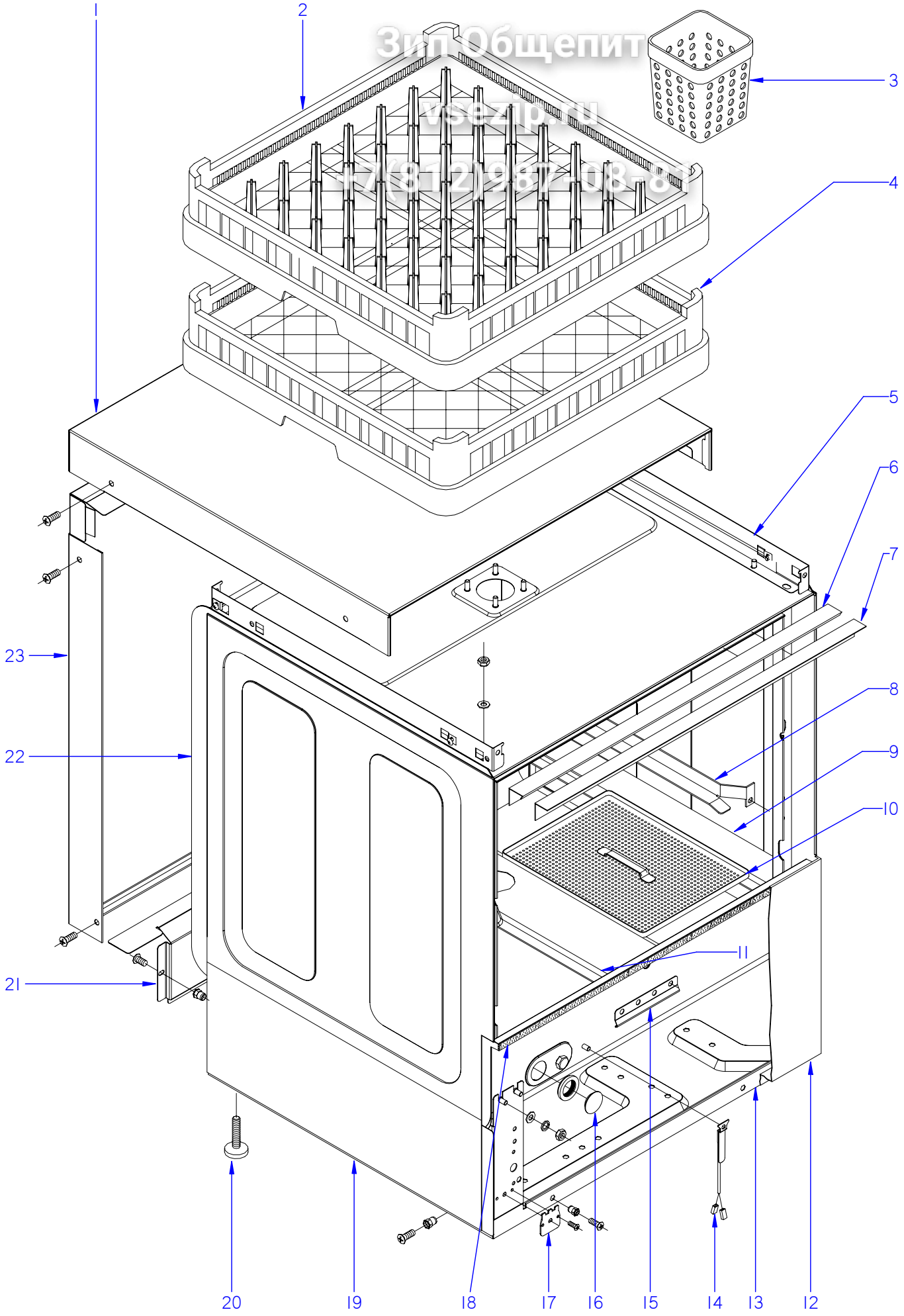

ITEM MARCADO EN COLOR = REPUESTO RECOMENDADO
COLOURED ITEM = RECOMMENDED SPARE PART

N plano	Firma	Fecha	Aparato	MUEBLE	Lamina	Fagor Industrial S.Coop. FAGOR
C-2460	<i>(Signature)</i>	2009-12	LAVAVAJILLAS AD-48		1	Oñate

MOD.	LAVAVAJILLAS DE APERTURA FRONTAL	ZONA	MUEBLE
-------------	---	-------------	---------------

ITEM	CODIGO	DENOMINACION	TEXTO	AD-48	AD-48 B	AD-48 C	AD-48 D	AD-48 DD
1	Z202929000	TAPA AD	COVER	1	1	—	1	1
1	Z212919000	TAPA DOBLE PARED AD48	COVER AD48	—	—	1	—	—
	Q152004000	TORNIL, APLASTADO M5x13 A304	FLAT HEADED BOLT M5x13 A304	6	6	6	6	6
2	Z655302000	CESTILLO PLATOS CP-16-18	BASKET CP-16-18	1	1	1	1	1
3	Z655314000	CESTILLO CUBIERTOS	CUTLERY BASKET	4	4	4	4	4
4	Z655301000	CESTILLO BASE CT-10	BASE BASKET CT-10	1	1	1	1	1
	Z209121000	TOPE 50x50x80	TOP 50x50x80	2	2	2	2	2
5	Z200329000	ESCUADRA AMARRE TAPA AF	FASTENING BRACKET COVER	2	2	—	2	2
5	Z210301000	ESCUADRA AMARRE P.LATERAL	FASTENING BRACKET	—	—	2	—	—
S/Nº	Z210302000	ESCUADRA DOBLE PARED	FASTENING	—	—	4	—	—
	Q232040000	ARANDELA A6	WASHER A6	4	4	4	4	4
	Q162040000	TUERCA EXAGONAL M6	HEXAGONAL NUT M6	4	4	4	4	4
	Q221012000	TUERCA RAPIDA M,5	RAPID NUT M,5	6	6	6	6	6
	Q012073000	TORNILLO EXAGONAL M12X20	HEXAGONAL BOLT M12X20	3	3	3	3	3
	Q306024000	JUNTA18X12.5X1.5	SEAL 18X12.5X1.5	3	3	3	3	3
	Q162070000	TUERCA EXAGONAL M12	HEXAGONAL NUT M12	3	3	3	3	3
6	Z200315000	PERFIL CAJA	BOX PROFILE	1	1	1	1	1
7	Z200309000	ESCUADRA SUJECCION PERFIL	FASTENING BRACKET PROFILE	1	1	1	1	1
8	Z200305000	GUIA CESTILLO DERECHO	RIGHT BASKET GUIDE	1	1	1	1	1
S/Nº	Z200306000	GUIA CESTILLO IZQUIERDO	LEFT BASKET GUIDE	1	1	1	1	1
	Q162040000	TUERCA EXAGONAL M6	WASHER A6	4	4	4	4	4
	Q232040000	ARANDELA A6	HEXAGONAL NUT M6	4	4	4	4	4
9	Z210805000	SOPORTE DERECHO BANDEJAS	RIGHT TRAY SUPPORT	1	1	1	1	1
S/Nº	Z210806000	SOPORTE IZDO. BANDEJAS	LEFT TRAY SUPPORT	1	1	1	1	1
	Q162040000	TUERCA EXAGONAL M6	HEXAGONAL NUT M6	4	4	4	4	4
	Q232040000	ARANDELA A6	WASHER A6	4	4	4	4	4
10	Z210802000	BANDEJA COMPLETA	COMPLETE TRAY	4	4	4	4	4
11	Z210804000	SOPORTE CENTRAL BANDEJAS	TRAY SUPPORT CENTRAL	1	1	1	1	1
12	Z202913000	PANEL FRONTAL SIN PUERTA	FRONT PANEL	1	—	—	1	1
12	Z228812000	PANEL FRONTAL B SIN PUERTA	FRONT PANEL B	—	1	1	—	—
	Q152004000	TORNIL, APLASTADO M5x13 A304	FLAT HEADED BOLT M5x13 A304	2	2	2	2	2

ITEM	CODIGO	DENOMINACION	TEXTO	AD-48	AD-48 B	AD-48 C	AD-48 D	AD-48 DD
MOD. LAVAVAJILLAS DE APERTURA FRONTAL				ZONA MUEBLE				
13	Z200101000	ARMAZON COMPLETO	COMPLETE FRAME	1	1	1	1	1
14	Z713028000	SONDA TEMPERATURA GICAR	TEMPERATURA PROBE GICAR	1	1	1	1	1
S/Nº	Z718004000	AMARRE SONDA	PROBE CATCH	1	1	1	1	1
	Q162020000	TUERCA EXAGONAL M4	HEXAGONAL NUT M4	1	1	1	1	1
15	Z748008000	SOPORTE BULBO TERMOSTATO	THERMOSTAT BULB SUPPORT	1	1	1	1	1
	Q162040000	TUERCA EXAGONAL M6	HEXAGONAL NUT M6	2	2	2	2	2
	Q262040000	ARANDELA GROW. A6 A.304	WASHER GROW. A6 A.304	2	2	2	2	2
16	P443060000	TAPON	STOPPER	1	1	1	1	1
	N503017000	SOPORTE TERMOSTATO 1001713	THERMOSTAT SUPPORT 100171	1	1	1	1	1
17	Z713038000	REGU. TERMOS. TANQUE 60 °C	THERM.TANQUE REGULATOR	1	1	1	1	1
18	Z200313000	PERFIL GOMA ESPONJOSA	GOMA PROFILE	1	1	1	1	1
19	Z202903000	PANEL LATERAL IZQUIERDO	LEFT SIDE PANEL	1	1	—	1	1
19	Z212917000	PANEL LATERAL IZDO. DOBLE P.	LEFT SIDE PANEL	—	—	1	—	—
S/Nº	Z202902000	PANEL LATERAL DERECHO	RIGHT SIDE PANEL	1	1	—	1	1
S/Nº	Z212918000	PANEL LATERAL DCHO. DOBLE P.	RIGHT SIDE PANEL	—	—	1	—	—
	Q152004000	TORNIL, APLASTADO M5x13 A304	FLAT HEADED BOLT M5x13 A304	4	4	4	4	4
	Q221012000	TUERCA RAPIDA M,5	RAPID NUT M,5	2	2	2	2	2
20	Z200107000	PATA REGULABLE	ADJUSTABLE LEG	4	4	4	4	4
21	Z202921000	PANEL POSTERIOR INFERI. ALUM.	LOWER REAR PANEL ALUM.	1	1	1	1	1
	Q152004000	TORNIL, APLASTADO M5x13 A304	FLAT HEADED BOLT M5x13 A304	2	2	2	2	2
22	Z200341000	CAJA SOLDADA LJ. A.F. AD	WELDED BOX LJ. A.F. AD	1	1	1	—	1
22	Z200343000	CAJA SOLDADA LJ. A.F. AD "D"	WELDED BOX LJ. A.F. AD "D"	—	—	—	1	—
	Q162040000	TUERCA EXAGONAL M6	HEXAGONAL NUT M6	8	8	8	8	8
	Q302022000	ARANDELA 16X6X1.2 A.304	WASHER 16X6X1.2 A.304	8	8	8	8	8
	Q262040000	ARANDELA GROW. A6 A.304	WASHER GROW. A6 A.304	8	8	8	8	8
23	Z202904000	PANEL POSTERIOR ALU.FI-30	REAR PANEL ALU.FI-30	1	1	—	1	1
23	Z212920000	PANEL POSTER. DOBLE PARED	REAR PANEL ALU.FI-30	—	—	1	—	—
	Q152004000	TORNIL, APLASTADO M5x13 A304	FLAT HEADED BOLT M5x13 A304	4	4	4	4	4

Зип Общежит

vsezip.ru

+7(812)987-08-81

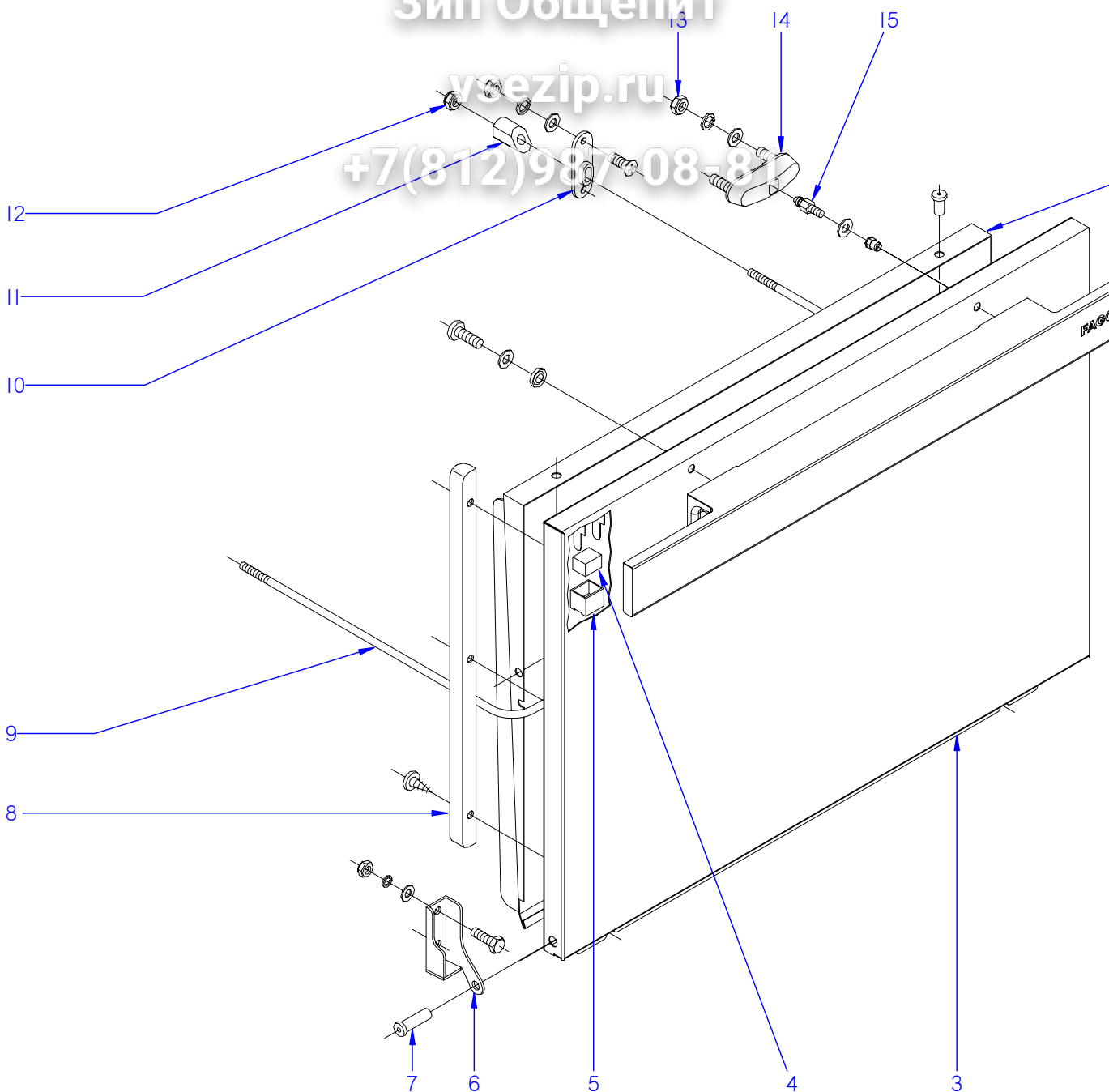

ITEM MARCADO EN COLOR = REPUESTO RECOMENDADO
COLOURED ITEM = RECOMMENDED SPARE PART

N plano	C-2461
Firma	
Fecha	2009-12
Aparato	PUERTA LAVAVAJILLAS AD-48
Lamina	2
Order	Fagor Industrial S. Coop.

MOD.	LAVAVAJILLAS DE APERTURA FRONTAL	ZONA	PUERTA
-------------	---	-------------	---------------

ITEM	CODIGO	DENOMINACION	TEXTO	AD-48	AD-48 B	AD-48 C	AD-48 D	AD-48 DD
1	Z200556000	CONTRAPUERTA COMPLETA	COMPL. DOOR REVERSE	1	1	1	1	1
	Q412000000	REMACHE TUBULAR 4 x 8	TUBULAR RIVET 4 x 8	4	4	4	4	4
	Q162030000	TUERCA EXAGONAL M5	HEXAGONAL NUT M5	2	2	2	2	2
	Q232030000	ARANDELA A5	WASHER A5	2	2	2	2	2
	Q262030000	ARANDELA GROW. A5 A.304	WASHER GROW. A5 A.304	2	2	2	2	2
2	Z200558000	ASA FI 30	HANDLE FI30	1	1	—	1	1
2	Z210501000	ASA AD-48 C	HANDLE AD-48 C	—	—	1	—	—
S/Nº	Z200564000	TACO SUJECCION	FASTENING RAWL	2	2	2	2	2
3	Z200561000	PUERTA COMPLETA AD	COMPLETE DOOR AD	1	1	1	1	1
4	Z200506000	IMAN	MAGNET	1	1	1	1	1
5	Z200507000	PROTECTOR IMAN	MAGNET PROTECTOR	1	1	1	1	1
6	Z400514000	BISAGRA IZQUIERDA T-C.	LEFT HINGE T-C.	1	1	1	1	1
S/Nº	Z400515000	BISAGRA DERECHA T-C.	RIGHT HINGE T-C.	1	1	1	1	1
	Q012042000	TORNILLO EXAGONAL M6X15	HEXAGONAL BOLT M6x15	4	4	4	4	4
	Q232040000	ARANDELA A6	WASHER A6	4	4	4	4	4
	Q262040000	ARANDELAGROW. A6 A.304	WASHER GROW. A6 A.304	4	4	4	4	4
	Q162040000	TUERCA EXAGONAL M6	HEXAGONAL NUT M6	4	4	4	4	4
7	Z400516000	EJE PUERTA	DOOR SHAFT	2	2	2	2	2
8	Z200524000	MARCO PUERTA	DOOR FRAME	2	2	2	2	2
	Q412000000	REMACHE TUBULAR 4 x 8	TUBULAR RIVET 4 x 8	6	6	6	6	6
9	Z200555000	VARILLA TENSOR	TIGHTENER ROD	1	1	1	1	1
10	Z200310000	SOPORTE TENSOR	TIGHTENER SUPPOR	2	2	2	2	2
	Q152004000	TORNIL, APLASTADO M5x13 A304	FLAT HEADED BOLT M5x13 A304	4	4	4	4	4
	Q162030000	TUERCA EXAGONAL M5	HEXAGONAL NUT M5	4	4	4	4	4
	Q232030000	ARANDELA A5	WASHER A5	4	4	4	4	4
	Q262030000	ARANDELA GROW. A5 A.304	WASHER GROW. A5 A.304	4	4	4	4	4
11	Z200522000	TENSOR PUERTA	TIGHTENER DOOR	2	2	2	2	2
12	Q222012000	TUERCA AUTOB. M6	SELF-LOCKING NUT M6	2	2	2	2	2
13	Q222012000	TUERCA AUTOB. M6	SELF-LOCKING NUT M6	4	4	4	4	4
14	Z200607000	CONJUNTO CIERRE PUER.T-CO	LOCK UNIT PUERTAT-CO	2	2	2	2	2
15	Z200601000	ENGANCHE CIERRE	LOCK LATCH	2	2	2	2	2

Зип Общежит
 vsezip.ru
 7(812)987-08-81

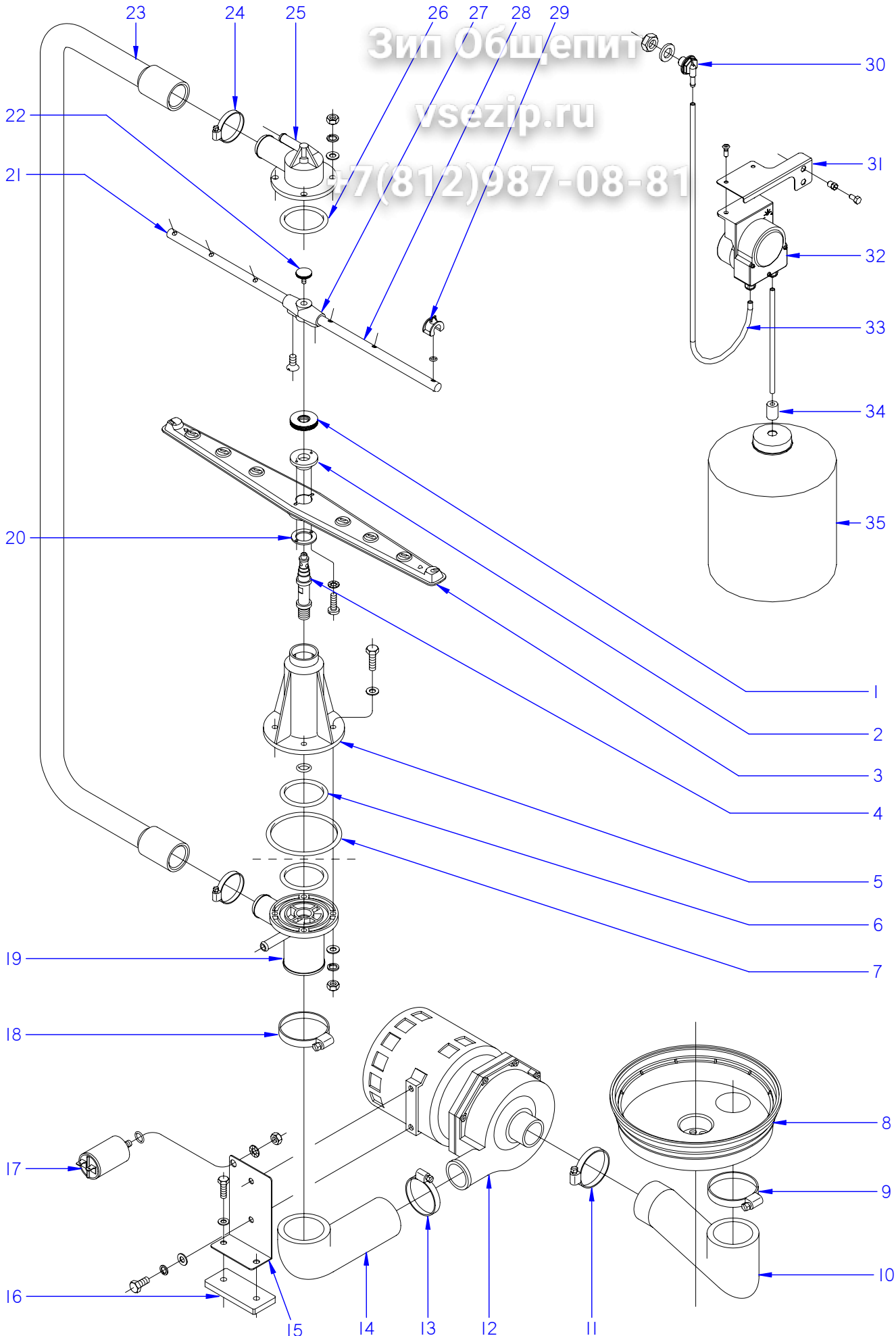

ITEM MARCADO EN COLOR = REPUESTO RECOMENDADO
 COLOURED ITEM = RECOMMENDED SPARE PART

N plano	Firma	Fecha	Aparato	CONJUNTO FUNCIONAL DE LAVADO	Lamina	Fagor Industrial S.Coop. FAGOR
C-2462	<i>(Signature)</i>	2009-12	LAVAVAJILLAS AD-48		3	Oñate

MOD.	LAVAVAJILLAS DE APERTURA FRONTAL	ZONA	CONJUNTO FUNCIONAL DE LAVADO
------	----------------------------------	------	------------------------------

ITEM	CODIGO	DENOMINACION	TEXTO	AD-48	AD-48 B	AD-48 C	AD-48 D	AD-48 DD
1	Z200705000	TUERCA ESPECIAL M.14X1	SPECIAL NUT M.14X1	2	2	2	2	2
2	Z650704000	ENGANCHE DISTRIBUIDOR	DISTRIBUTOR CATCH	2	2	2	2	2
3	Z650716000	DISTRIBUIDOR MONTADO	DISTRIBUTOR	2	2	2	2	2
4	Z200704000	EJE CENTRAL	CENTRAL SHAFT	2	2	2	2	2
5	Z200701000	SOPORTE DISTRIBUID. INFERIOR	LOWER DISTRIB. SUPPORT	1	1	1	1	1
	Q307050000	JUNTA TOR.13.94X19.18X2.6	O-RING 13.94X19.18X2.6	1	1	1	1	1
	Q012046000	TORNIL. EXAGONAL M6X40 A.304	HEXAGONAL BOLT M6X40 A.304	4	4	4	4	4
	Q306050000	ARANDELA Ø6X12X1.5	WASHER Ø6X12X1.5	4	4	4	4	4
6	Q307052000	JUNTA TOR.50.17X60.83X5.3	O-RING 50.17X60.83X5.3	2	2	2	2	2
7	Q307049000	JUNTA TOR.85.09X95.75X5.3	O-RING 85.09X95.75X5.3	1	1	1	1	1
8	Z200906000	CUBETA	TRAY	1	1	1	1	1
9	Q881324000	ABRAZADERA 50-70L	CLAMP 50-70L	1	1	1	1	1
10	Z200904000	CODO ASPIRACION 1003018	EXTRACTOR ELBOW	1	1	1	1	1
11	Q881324000	ABRAZADERA 50-70L	CLAMP 50-70L	1	1	1	1	1
12	Z201011000	BOMBA DE LAVADO	WASH PUMP	1	1	1	1	1
12	Z203511000	BOMBA DE LAVADO 60 HZ.	WASH PUMP 60 HZ.	1	-	-	-	-
13	Q881307000	ABRAZADERA 40-60	CLAMP 40-60	1	1	1	1	1
14	Z200905000	CODO IMPULSION 1003017	IMPULSE ELBOW 1003017	1	1	1	1	1
15	Z201002000	SOPORTE MOTOBO.F-3-4-5-6	MOTOR PUMP SUPPORT	1	1	1	1	1
	Q012041000	TORNIL. EXAGONAL M6X10 A.304	HEX BOLT M6X10 A.304	2	2	2	2	2
	Q232040000	ARANDELA A6	FAN WASHER A6	2	2	2	2	2
	Q262040000	ARANDELA GROW. A6 A.304	WASHER GROW. A6 A.304	2	2	2	2	2
16	Z201003000	BASE BOMBA LAVADO 1003016	WASH PUMP BASE	1	1	1	1	1
	Q012033000	TORNIL. EXAGONAL M5X20 A.304	HEX BOLT M5X20 A.304	2	2	2	2	2
	Q232030000	ARANDELA A5	FAN WASHER A5	2	2	2	2	2
17	V321300000	CONDENSADOR 10 M.F.	CONDENSER 10 M.F.	1	1	1	1	1
	Q307048000	JUNTA TORICA 9.12X16.18X3.53	O-RING 9.12X16.18X3.53	1	1	1	1	1
	Q162050000	TUERCA EXAGONAL M8x1 INOX.	HEXAGONAL NUT M8x1 INOX.	1	1	1	1	1
	Q261050000	ARANDELA MUELLE A8	SPRING WASHER A8	1	1	1	1	1
18	Q881324000	ABRAZADERA 50-70L	CLAMP 50-70L	1	1	1	1	1

MOD.	LAVAVAJILLAS DE APERTURA FRONTAL	ZONA	CONJUNTO FUNCIONAL DE LAVADO
------	----------------------------------	------	------------------------------

ITEM	CODIGO	DENOMINACION	TEXTO	AD-48	AD-48 B	AD-48 C	AD-48 D	AD-48 DD
19	Z200703000	PASAMUROS	WALL BUSHING	1	1	1	1	1
	Q232040000	ARANDELA A6	WASHER A6	4	4	4	4	4
	Q262040000	ARANDELA GROW. A6 A.304	WASHER GROW. A6 A.304	4	4	4	4	4
	Q162040000	TUERCA EXAGONAL M6	HEXAGONAL NUT M6	4	4	4	4	4
20	Z650711000	AMARRE ENGANCHE DISTRIBUID.	DISTRIBUT. CATCH FASTENING	2	2	2	2	2
	Q152015000	TORNILLO ALOMADO M3X6	CURVED SCREW M3X6	4	4	4	4	4
	Q242010000	ARANDELA ABANICO A.3 A304	FAN WASHER A.3 A304	4	4	4	4	4
21	Z201902000	RAMA DE ACLARADO IZQUIERDA	LEF TRINSE BRANCH	2	2	2	2	2
22	Q152016000	TORNILLO ESPECIAL M.5X0.8	SPECIAL BOLT M.5X0.8	2	2	2	2	2
23	Z200706000	ARBOL DE LAVADO	WASH CAM	1	1	1	1	1
24	Q881305000	ABRAZADERA 25-40	CLAMP 25-40	2	2	2	2	2
25	Z200707000	SOPORTE DISTRIBUIDOR SUPER.	UPPER DISTRIB. SUPPORT	1	1	1	1	1
	Q232040000	ARANDELA A6	WASHER A6	4	4	4	4	4
	Q262040000	ARANDELA GROW. A6 A.304	WASHER GROW. A6 A.304	4	4	4	4	4
	Q162040000	TUERCA EXAGONAL M6	HEXAGONAL NUT M6	4	4	4	4	4
26	Q307052000	JUNTA TOR.50.17X60.83X5.3	O-RING 50.17X60.83X5.3	1	1	1	1	1
27	Z201903000	SOPORTE RAMAS ACLARADO	TRINSE BRANCH SUPPORT	2	2	2	2	2
	Q042021000	TORN. AVELLANADO M4X10 A.304	COUNTERSUNK BOLT M4X10 A3	4	4	4	4	4
28	Z201901000	RAMA DE ACLARADO DERECHA	RIGHT TRINSE BRANCH	2	2	2	2	2
29	Z211903000	TOBERA ACLARADO	RINSE NOZZLE	12	12	12	12	12
30	Z230905000	PASAMUROS DETERGENTE	INOX DETERGENT WALL BUSHIN	-	-	1	-	1
31	Z208434000	SOPORTE DOSIFICADOR W	DOSEFOR W SUPPORT	-	-	1	-	1
	Q411304000	REMACHE AVIBULB Ø4,8	AVIBULB Ø4,8 RIVET	-	-	2	-	2
	Q012031000	TORNIL.EXAGONAL M5X10 A.304	HEXAGONAL BOLT M5X10	-	-	2	-	2
32	Z208903000	DOSIFIC. DGTE REGULABLE G300	DOSEFOR DETERGENT	-	-	1	-	1
33	Z448614000	CONDUCTO ASPIRACIÓN	CONDUIT	-	-	1	-	1
S/Nº	3699300000	CONDUCTO DOSIFICAFOR TRANS.	CONDUIT	-	-	1	-	1
34	Z701152000	PESO FILTRO	FILTER WEIGHT	-	-	1	-	1
35	-	GARRAFA DETERGENTE	DETERGENT CAN	-	-	1	-	1

Зип Общежит

vsezip.ru

+7(812)987-08-81

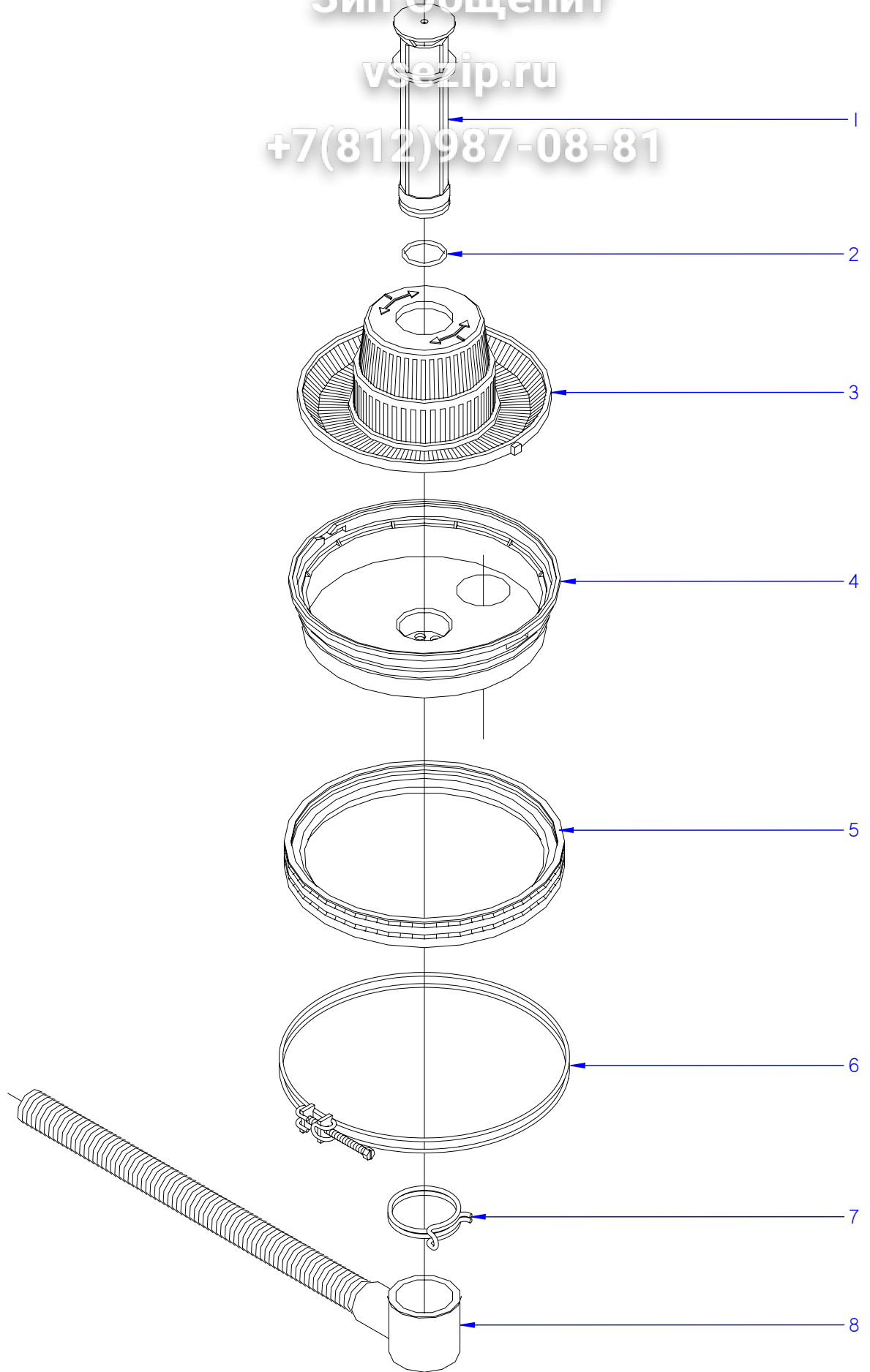

ITEM MARCADO EN COLOR = REPUESTO RECOMENDADO
COLOURED ITEM = RECOMMENDED SPARE PART

N plano	Firma	Fecha	Aparato	CONJUNTO FUNCIONAL DESAGUE	Lamina	Fagor Industrial S.Coop. FAGOR
C-2463	<i>(Signature)</i>	2009-12	LAVAVAJILLAS AD-48 / 48D / 48DD	4	Note	

Зип Общепит

vsezip.ru

+7(812)987-08-81

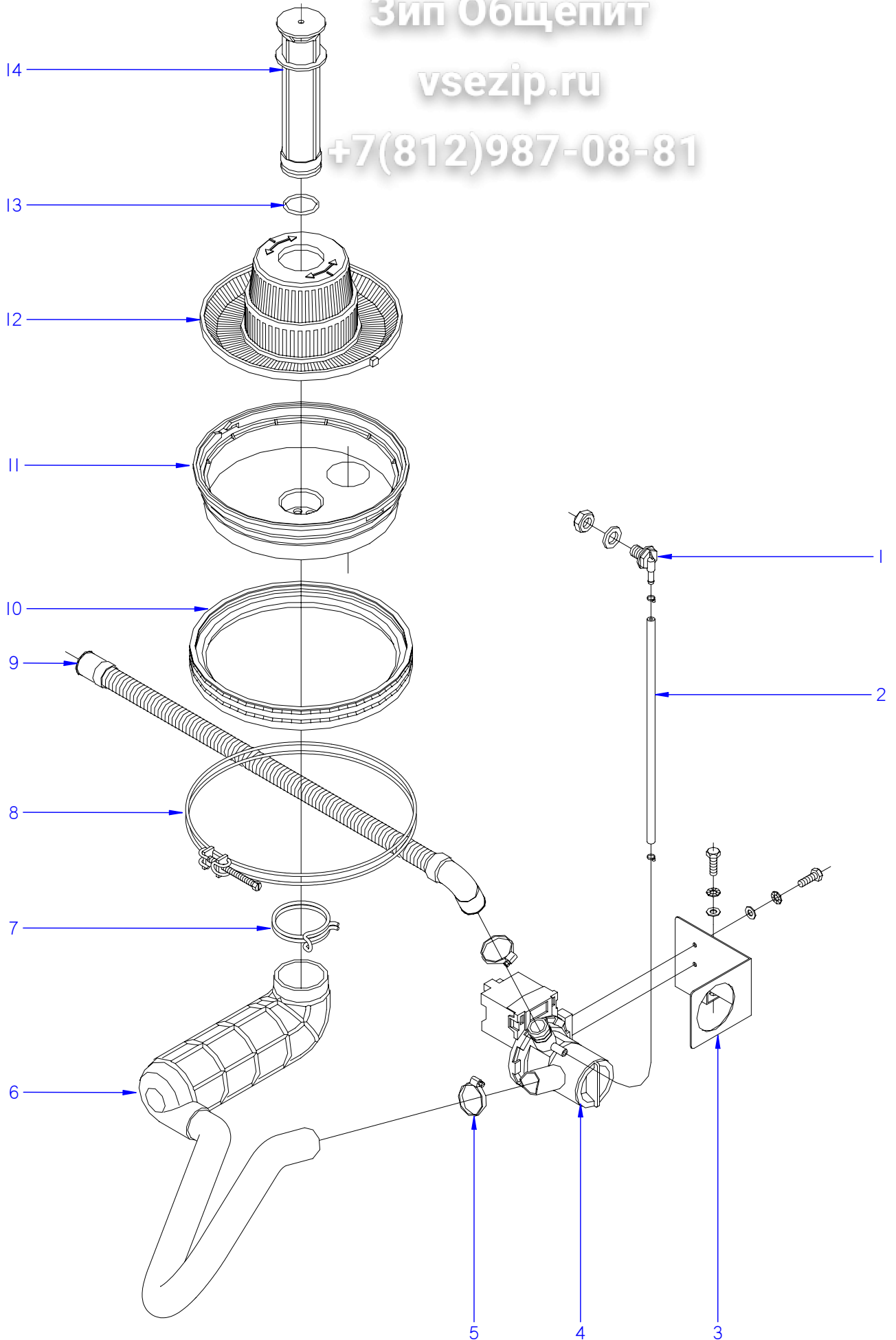

ITEM MARCADO EN COLOR = REPUESTO RECOMENDADO
COLOURED ITEM = RECOMMENDED SPARE PART

N plano	Firma	Fecha	Aparato	CONJUNTO FUNCIONAL DESAGUE	Lamina	Fagor Industrial S.Coop. FAGOR
C-2464	<i>(Signature)</i>	2009-12	LAVAVAJILLAS AD -48 B / AD-48 C		5	Oñate

Зип Общежит

vsezip.ru

7(812)987-08-81

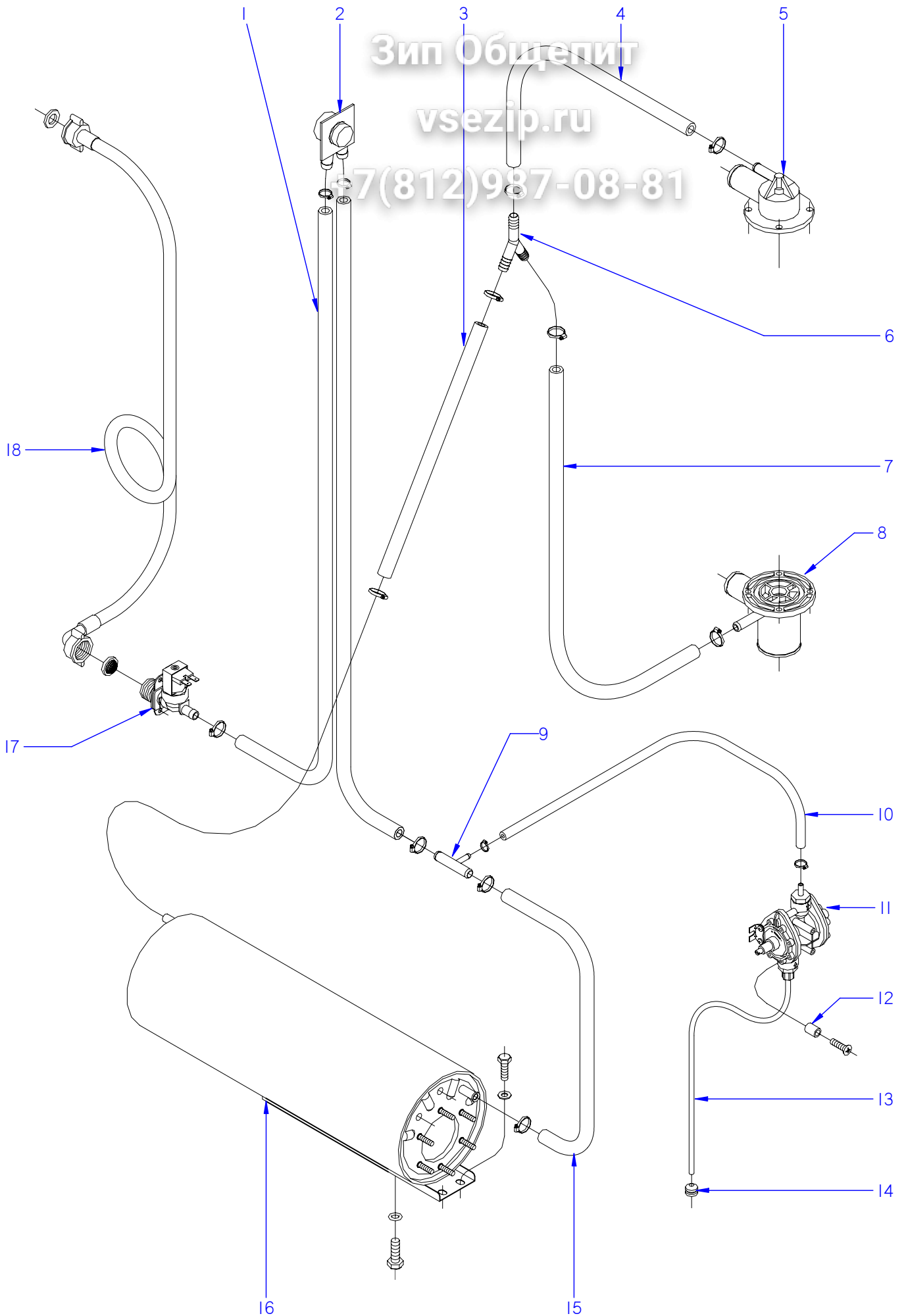

ITEM MARCADO EN COLOR = REPUESTO RECOMENDADO
COLOURED ITEM = RECOMMENDED SPARE PART

N plano	Firma	Fecha	Aparato	CONJUNTO FUNCIONAL ACLARADO	Lamina	Fagor Industrial S.Coop. FAGOR
C-2465	<i>[Signature]</i>	2009-12	LAVAVAJILLAS AD-48	6	Oñate	

MOD.	LAVAVAJILLAS DE APERTURA FRONTAL	ZONA	CONJUNTO FUNCIONAL ACLARADO
------	----------------------------------	------	-----------------------------

ITEM	CODIGO	DENOMINACION	TEXTO	AD-48	AD-48 B	AD-48 C	AD-48 DD
1	3676900000	TUBO GOMA NEGRA Ø 17*10	BLACK RUBBER PIPE Ø17*10	2	2	2	2
	Q881302000	ABRAZADERA 12-20	CLAMP 12/20	4	4	4	4
2	Z231106000	VALVULA ANTIRRETORNO	NON-RETURN VALVE	1	1	1	1
	Q881302000	ABRAZADERA 12/20	CLAMP 12/20	2	2	2	2
3	3676900000	TUBO GOMA NEGRA Ø 17*10	BLACK RUBBER PIPE Ø17*10	1	1	1	1
	Q881302000	ABRAZADERA 12-20	CLAMP 12/20	2	2	2	2
4	3676900000	TUBO GOMA NEGRA Ø 17*10	BLACK RUBBER PIPE Ø17*10	1	1	1	1
	Q881302000	ABRAZADERA 12-20	CLAMP 12/20	2	2	2	2
5	Z200707000	SOPORTE DISTRIB. SUPERIOR	UPPER DISTRIB. SUPPORT	1	1	1	1
6	Z201106000	RACORD EN Y	Y CONNECTION	1	1	1	1
7	3676900000	TUBO GOMA NEGRA Ø 17*10	BLACK RUBBER PIPE Ø17*10	1	1	1	1
	Q881302000	ABRAZADERA 12-20	CLAMP 12/20	1	1	1	1
8	Z200703000	PASAMUROS	WALL BUSHING	1	1	1	1
	Q881302000	ABRAZADERA 12-20	CLAMP 12/20	1	1	1	1
9	Z601157000	TOMA PRESION	PRESSURE INTAKE	1	1	1	1
10	3704000000	TUBO GOMA NEGRO Ø 10,5*5	BLACK RUBBER PIPE Ø 10,5*5	1	1	1	1
	Q881308000	ABRAZADERA 8-14L	CLAMP 8-14L	2	2	2	2
11	Z211109000	DOSIFICADOR TENSOACTIVO N-6	SURFACE ACT. DISP. N-6	1	1	1	1
12	Z203007000	CASQUILLO	CASE	2	2	2	2
	Q041324000	TORN. AVELLA. M4x25 H.ZINCADO	COUNTERSUNK BOLT M4x25	2	2	2	2
13	Z448618000	CONDUCTO ABRILLANTADOR	POLISH DUCT	1	1	1	1
14	Z701152000	PESO FILTRO	FILTER WEIGHT	1	1	1	1
15	3676900000	TUBO GOMA NEGRA Ø 17*10	BLACK RUBBER PIPE Ø17*10	1	1	1	1
	Q881302000	ABRAZADERA 12-20	CLAMP 12/20	2	2	2	2
16	Z201710000	CALDERIN COMPLETO	COMPL. BOILER	1	1	1	1
	Q012063000	TORNIL. EXAGONAL M10x20 A.304	HEXAGONAL BOLT M10x20 A304	1	1	1	1
	Q307048000	JUNTA TORICA Ø9.12X16.18X3.53	O-RING Ø9.12X16.18X3.53	1	1	1	1
	Q012031000	TORNIL. EXAGONAL M5x10 A.304	HEXAGONAL BOLT M5x10 A.304	2	2	2	2
	Q232030000	ARANDELA A5	WASHER A5	2	2	2	2

Зип Общепит

vsezip.ru

+7(812)987-08-81

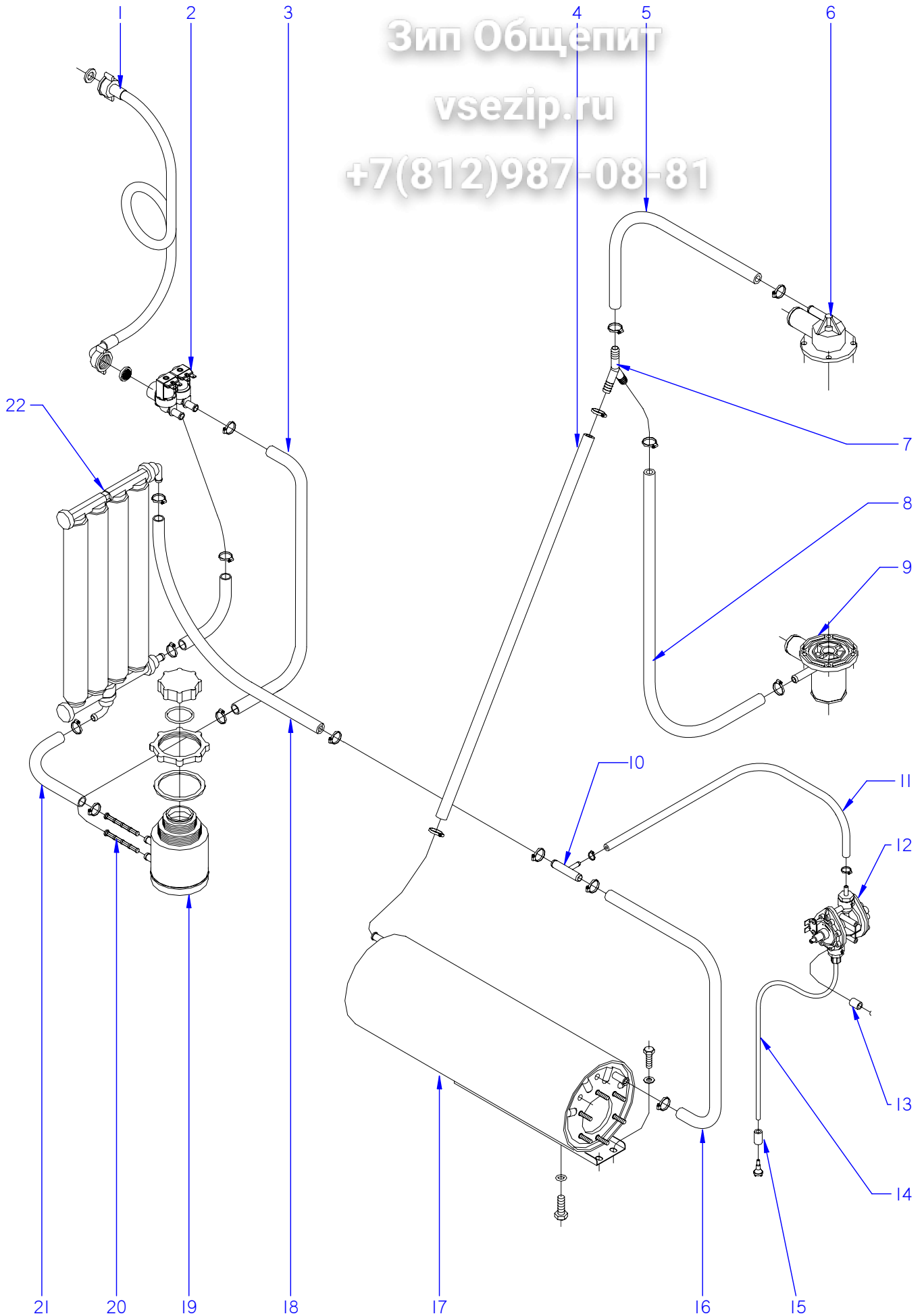

ITEM MARCADO EN COLOR = REPUESTO RECOMENDADO
COLOURED ITEM = RECOMMENDED SPARE PART

N plano	Firma	Fecha	Aparato	CONJUNTO FUNCIONAL ACLARADO	Lamina	Fagor Industrial S.Coop. FAGOR
C-2466	<i>(Signature)</i>	2009-12	LAVAVAJILLAS AD-48 D		7	Oñate

MOD.
LAVAVAJILLAS DE APERTURA FRONTAL
ZONA
vsezip.ru
CONJUNTO FUNCIONAL ACLARADO

ITEM	CODIGO	DENOMINACION	TEXTO	AD-48 D				
1	Z602121000	MANGUERA ENTRADA AGUA	WATER INTAKE HOSE	1				
2	P255001000	ELECTROVALVULA DOBLE	DOUBLE SOLENOID VALVE	1				
	P305013000	REGULADOR 1L. AMA 255.005	REGULATOR 1L. AMA 255.005	1				
	Q152024000	TORN. AVELLANADO M4x8 A.304	COUNTERSUNK BOLT M4x8	2				
3	3676900000	TUBO GOMA NEGRA Ø 17*10	BLACK RUBBER PIPE Ø17*10	2				
	Q881302000	ABRAZADERA 12-20	CLAMP 12/20	4				
4	3676900000	TUBO GOMA NEGRA Ø 17*10	BLACK RUBBER PIPE Ø17*10	2				
	Q881302000	ABRAZADERA 12-20	CLAMP 12/20	4				
5	3676900000	TUBO GOMA NEGRA Ø 17*10	BLACK RUBBER PIPE Ø17*10	1				
	Q881302000	ABRAZADERA 12-20	CLAMP 12/20	2				
6	Z200707000	SOPORTE DISTRIB. SUPERIOR	UPPER DISTRIB. SUPPORT	1				
7	Z201106000	RACORD EN Y	Y CONNECTION	1				
8	3676900000	TUBO GOMA NEGRA Ø 17*10	BLACK RUBBER PIPE Ø17*10	1				
	Q881302000	ABRAZADERA 12-20	CLAMP 12/20	2				
9	Z200703000	PASAMUROS	WALL BUSHING	1				
10	Z601157000	TOMA PRESION	PRESSURE INTAKE	1				
11	3704000000	TUBO GOMA NEGRO Ø 10,5*5	BLACK RUBBER PIPE Ø 10,5*5	1				
	Q881308000	ABRAZADERA 8-14L	CLAMP 8-14L	2				
12	Z211109000	DOSIFICADOR TENSOACTIVO N-6	SURFACE ACT. DISP. N-6	1				
13	Z203007000	CASQUILLO	CASE	2				
	Q041324000	TORN. AVELLA. M4x25 H.ZINCADO	COUNTERSUNK BOLT M4x25	2				
14	Z448618000	CONDUCTO ABRILLANTADOR	POLISH DUCT	1				
15	Z701152000	PESO FILTRO	FILTER WEIGHT	1				
16	3676900000	TUBO GOMA NEGRA Ø 17*10	BLACK RUBBER PIPE Ø17*10	1				
	Q881302000	ABRAZADERA 12-20	CLAMP 12/20	2				
17	Z201710000	CALDERIN COMPLETO	COMPL. BOILER	1				
	Q012063000	TORNIL. EXAGONAL M10x20 A.304	HEXAGONAL BOLT M10x20 A304	1				
	Q307048000	JUNTA TORICA Ø9.12X16.18X3.53	O-RING Ø9.12X16.18X3.53	1				
	Q012031000	TORNIL. EXAGONAL M5x10 A.304	HEXAGONAL BOLT M5x10 A.304	2				
	Q232030000	ARANDELA A5	WASHER A5	2				

MOD.

LAVAVAJILLAS DE APERTURA FRONTAL

ZONA

CONJUNTO FUNCIONAL ACLARADO

vsezip.ru

+7(812)987-08-81

ITEM	CODIGO	DENOMINACION	TEXTO	AD-48 D				
18	3676900000	TUBO GOMA NEGRA Ø 17*10	BLACK RUBBER PIPE Ø17*10	1				
	Q881302000	ABRAZADERA 12-20	CLAMP 12/20	2				
19	Z471102000	DEPOSITO SOLDADO	WELDED TANK	1				
	Z471107000	JUNTA TUERCA (BITRON 15702.01)	NUT SEAL (BITRON 15702.01)	1				
	Z471106000	TUERCA (BITRON 27414.00)	NUT (BITRON 27414.00)	1				
	Z471109000	JUNTA TAPON (BITRON 06485.02)	PLUG SEAL (BITRON 06485.02)	1				
	Z471108000	TAPON (BITRON 27415.00)	PLUG (BITRON 27415.00)	1				
20	Z471105000	FILTRO (BITRON 06281.01)	FILTER (BITRON 06281.01)	2				
21	3676900000	TUBO GOMA NEGRA Ø17*10	BLACK RUBBER PIPE Ø17*10	1				
	Q881302000	ABRAZADERA 12/20	CLAMP 12/20	2				
22	Z471101000	DESCALCIFICADOR 4 COLUMNAS	WATER SOFTENER 4 COLUMN	1				
	Q152012000	PERNO SOLDADO M6X15	PERNO SOLDADO M6X15	2				
	Z471112000	SOPOR. INFERIOR DESCALCIFICAD	LOWER W-SOFT. SUPPORT.	2				

Зип Общепит

vsezip.ru

+7(812)987-08-81

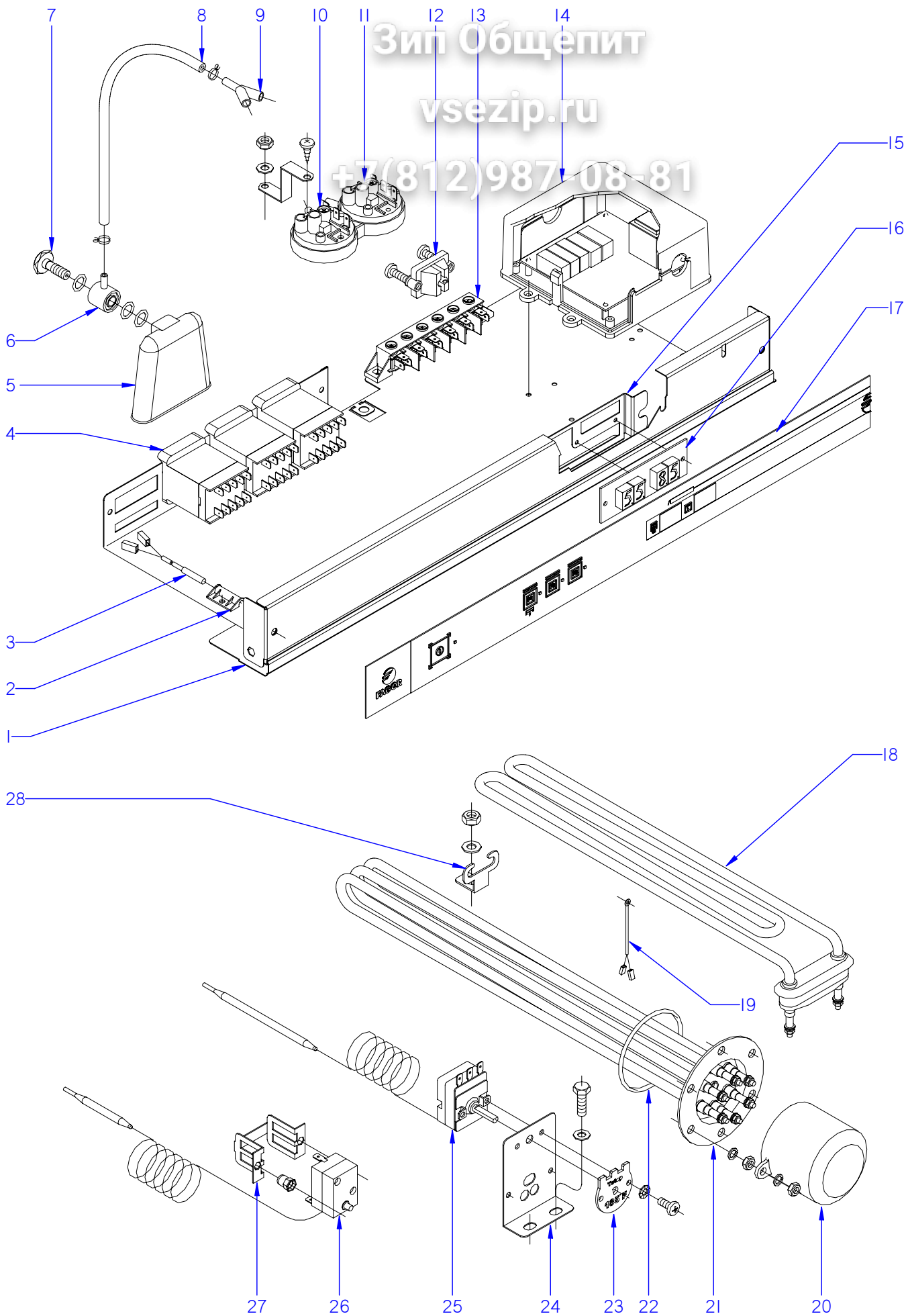

ITEM MARCADO EN COLOR = REPUESTO RECOMENDADO
COLOURED ITEM = RECOMMENDED SPARE PART

N plano	Firma	Fecha	Aparato	CONJUNTO FUNCIONAL ELECTRICO	Lamina	Fagor Industrial S.Coop. FAGOR
C-2467	<i>[Signature]</i>	2009-12	LAVAVAJILLAS AD-48		8	Oñate

MOD.
LAVAVAJILLAS DE APERTURA FRONTAL
ZONA
CONJUNTO FUNCIONAL ELECTRICO

ITEM	CODIGO	DENOMINACION	TEXTO	AD-48	AD-48 B	AD-48 C	AD-48 D	AD-48 DD
1	Z202930000	FRENTE COMPLETO AD	COMPLETE FRONT AD	1	1	1	1	1
2	Z203010000	AMARRE INTERRUPT. MAGNETICO	MAGNETIC SWITCH FASTENER	1	1	1	1	1
	Q232030000	ARANDELA A5	WASHER A5	1	1	1	1	1
	Q152004000	TORNILLO APLASTADO M5x13 A304	FLAT HEADED BOLT M5x13 A304	1	1	1	1	1
	Q162030000	TUERCA EXAGONAL M5	HEXAGONAL NUT M5	1	1	1	1	1
3	Z203009000	INTERRUPTOR MAGNETICO	MAGNETIC SWITCH	1	1	1	1	1
4	Z213007000	CONTACTOR 230 V. 50-60 HZ	CONTACTOR 230 V. 50-60 HZ	3	3	3	3	3
5	Z203011000	CAMARA PRESOSTATO	PRESSURE SWITCH	1	1	1	1	1
6	Z203012000	EMPALME PRESOSTATO	PRESSURE SWITCH CONNEX	1	1	1	1	1
7	Z203013000	TORNILLO PRESOSTATO	PRESSURE SWITCH BOLT	1	1	1	1	1
	Q307003000	JUNTA TORICA 16.01X10.77X2.62	O-RING 16.01X10.77X2.62	3	3	3	3	3
8	3702400000	TUBO GOMA NEGRO D 8*4	BLACK RUBBER PIPE Ø 8*4	1	1	1	1	1
	P102154000	BRIDA ELASTICA TUBO	ELASTIC PIPE FLANGE	2	2	2	2	2
9	Z103077000	RACORD EN Y	Y CONNECTION	—	1	1	—	—
10	Z203023000	PRESOSTATO SIMPLE PVS	SIMPLE PRESSURE SWITCH	1	1	1	1	1
11	Z223005000	PRESOSTATO SIMPLE P.V.S.	SIMPLE PRESSURE SWITCH	—	1	1	—	—
S/Nº	Z218002000	ESCUADRA AMARRE PRESOSTATO	PRESSURE SWITCH SQUARE	1	1	1	1	1
	Q082032000	TORNILLO ALOMADO BZ-3,5X9,5	ALOM. BOLT BZ-3,5X9,5	1	1	1	1	1
	Q152004000	TORNILLO APLASTADO M5x13 A304	FLAT HEADED BOLT M5x13 A304	1	1	1	1	1
	Q232030000	ARANDELA A5	WASHER A5	1	1	1	1	1
	Q162030000	TUERCA EXAGONAL M5	HEXAGONAL NUT M5	1	1	1	1	1
12	Z203020000	RETENEDOR DE CABLE	CABLE HOLDER	1	1	1	1	1
13	R253044000	REGLETA AUXILIAR FV-122	AUXILIARY STRIP FV-122	1	1	1	1	1
	Z213005000	ROTULO ADHESIVO	ADHES. LABEL	1	1	1	1	1
	Q152004000	TORNILLO APLASTADO M5x13	FLAT HEADED BOLT M5x13 A304	2	2	2	2	2
	Q232030000	ARANDELA A5	WASHER A5	2	2	2	2	2
	Q162030000	TUERCA EXAGONAL M5	HEXAGONAL NUT M5	2	2	2	2	2
14	Z213069000	TARJETA 5 RELES GICAR	CHAMBER 5 RELAY GICAR	1	1	1	1	1
	Q232020000	ARANDELA A4	WASHER A4	4	4	4	4	4
	Q242020000	ARANDELA ABANICO A5 A.304	FAN WASHER A4 A.304	4	4	4	4	4
	Q042022000	TORN. AVELLANADO M4X15	COUNTERSUNK BOLT M4X15	4	4	4	4	4

MOD.	LAVAVAJILLAS DE APERTURA FRONTAL	ZONA	CONJUNTO FUNCIONAL ELECTRICO
-------------	---	-------------	-------------------------------------

ITEM	CODIGO	DENOMINACION	TEXTO	AD-48	AD-48 B	AD-48 C	AD-48 D	AD-48 DD
15	Z203088000	SOPORTE COMPONENTES	COMPON. SUPPORT	1	1	1	1	1
	Q262030000	ARANDELA GROW. A5 A.304	WASHER GROW. A5 A.304	2	2	2	2	2
	Q162030000	TUERCA EXAGONAL M5	HEXAGONAL NUT M5	2	2	2	2	2
	R663036000	FIJACION CIRCUITO	CIRCUIT BINDINGS	3	3	3	3	3
16	Z713017000	DISPLAY GICAR TEMPERATURAS	DISPLAY GICAR	1	1	1	1	1
17	Z262908000	EMBELLECED. ADHESIVO AD-72	ADHES. TRIM AD-72	1	-	-	-	1
17	Z222904000	EMBELLECED. ADHESIVO AD-48 C	ADHES. TRIM AD-48 C	-	1	1	-	-
17	Z222906000	EMBELLECED. ADHESIVO AD-48 D	ADHES. TRIM AD-48 D	-	-	-	1	-
18	Z203601000	RESISTENCIA TANQUE	TANK RESISTOR	1	1	1	1	1
19	Z713028000	SONDA TEMPERATURA GICAR	TEMPERATURA PROBE GICAR	1	1	1	1	1
20	Z651731000	CAPERUZA RESISTENC. CALDERIN	BOILER RESIST. CAP	1	1	1	1	1
	Q163140000	TUERCA EXAGONAL M6 LATON	HEXAGONAL NUT M6 BRASS	2	2	2	2	2
	Q242030000	ARANDELA ABANICO A5 A.304	FAN WASHER A5 A.304	2	2	2	2	2
	Q152004000	TORNILLO APLASTADO M5x13 A304	FLAT HEADED BOLT M5x13 A304	2	2	2	2	2
21	Z201706000	RESISTENCIA CALDERIN	BOILER RESISTOR	1	1	1	1	1
	Q221305000	TUERCA EXAGONAL M4 ZINCADA	HEXAGONAL NUT M4 ZIN.	2	2	2	2	2
	Q163140000	TUERCA EXAGONAL M6 LATON	HEXAGONAL NUT M6 BRASS	5	5	5	5	5
	Q262040000	ARANDELA GROW. A6 A.304	WASHER GROW. A6 A.304	5	5	5	5	5
22	Q307035000	JUNTA TORICA AN-36 282333	"O" RING AN-36 282333	1	1	1	1	1
23	Z718446000	CHAPA W 85°C	W 85°C PLATE	1	1	1	1	1
24	Z203047000	SOPORTE TERMOSTATOS	THERMOSTAT SUPPORT	1	1	1	1	1
	Q012031000	TORNIL. EXAGONAL M5X10 A.304	HEXAGONAL BOLT M5X10	2	2	2	2	2
	Q232030000	ARANDELA A5	HEXAGONAL NUT M5	2	2	2	2	2
25	Z203014000	TERMOSTATO CALDERIN	WASH DRUM THERMOSTAT	2	2	2	2	2
26	Z213014000	LIMITADOR TECASA P.	TECASA P. LIMITER	1	1	1	1	1
27	Z203060000	AMARRE LIMITADOR TECASA	LIMITER FASTENING	1	1	1	1	1
	Q221341000	REMACHE EXAGONAL M4	HEXAGONAL RIVET M4	2	2	2	2	2
	Q152024000	TORNIL. AVELLANADO M4X8 A304	COUNTERSUNK BOLT M4x8	2	2	2	2	2
28	Z603602000	SOPORTE RESISTENCIA TANQUE	TANK RESISTOR SUPPORT	1	1	1	1	1
	Q232040000	ARANDELA A6	WASHER A6	1	1	1	1	1
	Q162040000	TUERCA EXAGONAL M6	HEXAGONAL NUT M6	1	1	1	1	1

MOD. LAVAVAJILLAS DE APERTURA FRONTAL		ZONA		VARIOS				
ITEM	CODIGO	DENOMINACION	TEXTO	AD-48	AD-48 B	AD-48 C	AD-48 D	AD-48 DD
	Z206133000	FOLLETO INSTRUCCIONES AD-48	INSTRUCTION LEAFLET. AD-48	1	1	1	1	1
	Z203090000	ESQUEMA TEORICO AD-48	THEORETICAL DIAGRAM AD	1	1	1	1	1
	Z213065000	PLANO DE MONTAJE AD-48	ASSEMBLY DIAGRAM AD	1	1	1	1	1
	Z213064000	INSTALACION ELECTRICA AD-48	ELEC. INSTALATION AD-48	1	1	1	1	1
	Z203094000	CABLE DE ALIMENTACION	SUPPLY CABLE	1	1	1	1	1
	Z213063000	CABLEADO CONEXIÓN SONDAS	PROBE CONNECTION WIRING	1	1	1	1	1
	Z713021000	CABLE CONEXION PLACA-DISPLAY	DISPLAY CONNECTI. WIRING	1	1	1	1	1
	Z208904000	CABLEADO DOSIFICADOR DTGTE	DOSEFOR DETERGEN. WIRING	--	--	1	--	1
	Z253046000	CABLEADO BOMBA DESAGUE	DRAINAGE PUMP WIRING	--	--	1	--	--

AD 48, AD 48 AR+DD, AD 48 B, AD 48 BA, AD 48 B BT, AD 48 C, AD 48 D, AD 48 HY, AD 48 W

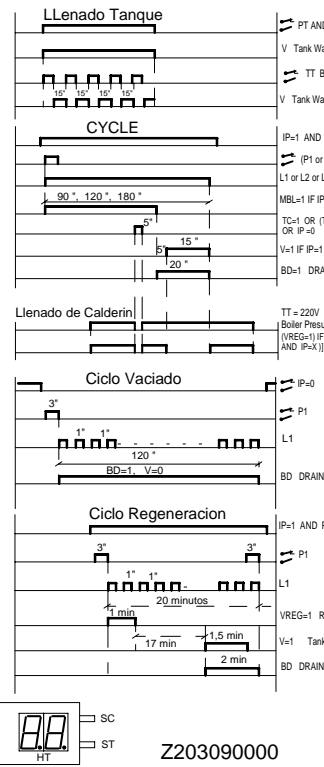
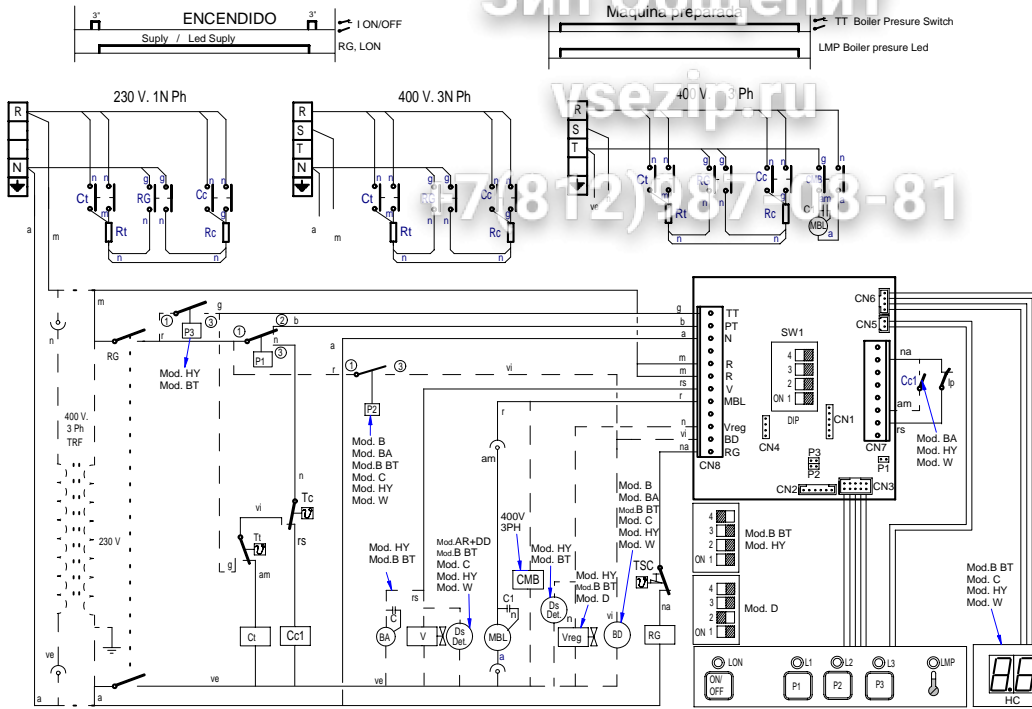

FAGOR ELECTRONICO MODELO ADVANCE	DIP1	DIP2	DIP3	DIP4	TIEMPOS CICLOS
AD-48, AD-48 B, AD-48 DD, AD-48 B BT, AD-64, AD-64 B, AD-64 DD, AD-64 B BT, AD-72.	OFF	OFF	ON	OFF	P1=60 / P2= 90 / P3=
AD-48 D, AD-64 D	OFF	ON	ON	OFF	
AD-48 C, AD-48 W, AD-48 HY, AD-64 C, AD-64 W, AD-64 HY, AD-72 W	OFF	OFF	ON	ON	

DIP1 = ON, al cerrar la puerta o bajar capó el lavavajillas se pone en marcha.
 DIP1 = OFF, al cerrar la puerta o bajar el capo el lavavajillas sigue lavando SÓLO SI EL CICLO NO HA ACABADO.

DIP2 = ON, Para los modelos que llevan DESCALCIFICADOR, versiones "D".
 DIP2 = OFF, para los modelos con BOMBA DESAGÜE, versiones "B".

DIP1 + DIP3, con las diferentes combinaciones posibles configuramos los tiempos de ciclo.

DIP4 = ON, TERMOSTOP ACTIVADO, para los modelos con termo stop, versiones "C", "W" y "HY".
 DIP4 = OFF, TERMOSTOP DESACTIVADO, para los modelos que NO llevan TERMOSTOP.

-	Esquema teorico L.A.F. AD 48	
Zk./Nº	Pieza	
Zk./Nº	Aidaketa/Modificaciones	
.	.	
.	.	
.	.	
.	.	
.	.	
.	.	
Sinadura/Firma		Data/Fe
Marratzua/Dibujado		M.Maillo 30-05-2
Proiektatua/Proyectado		M.Maillo 30-05-2
Egiaztatua/Comprobado		Z. Alube 30-05-2
Eskala/Escala		
.		
Plano hau ezin daiteke er		

Зип Общедит
vsezip.ru

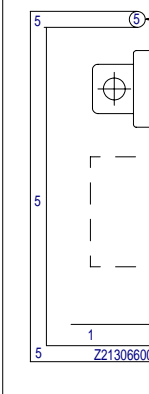
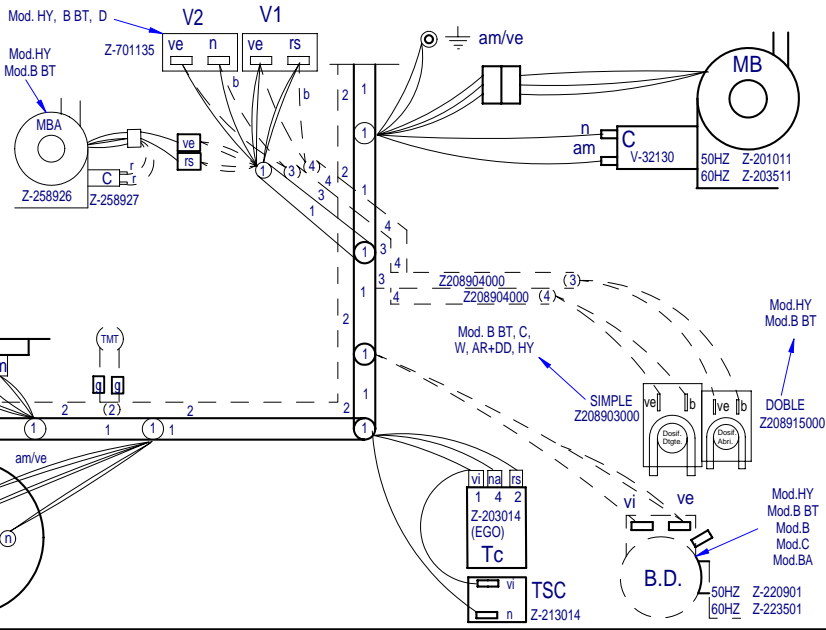
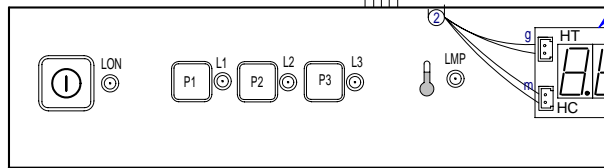
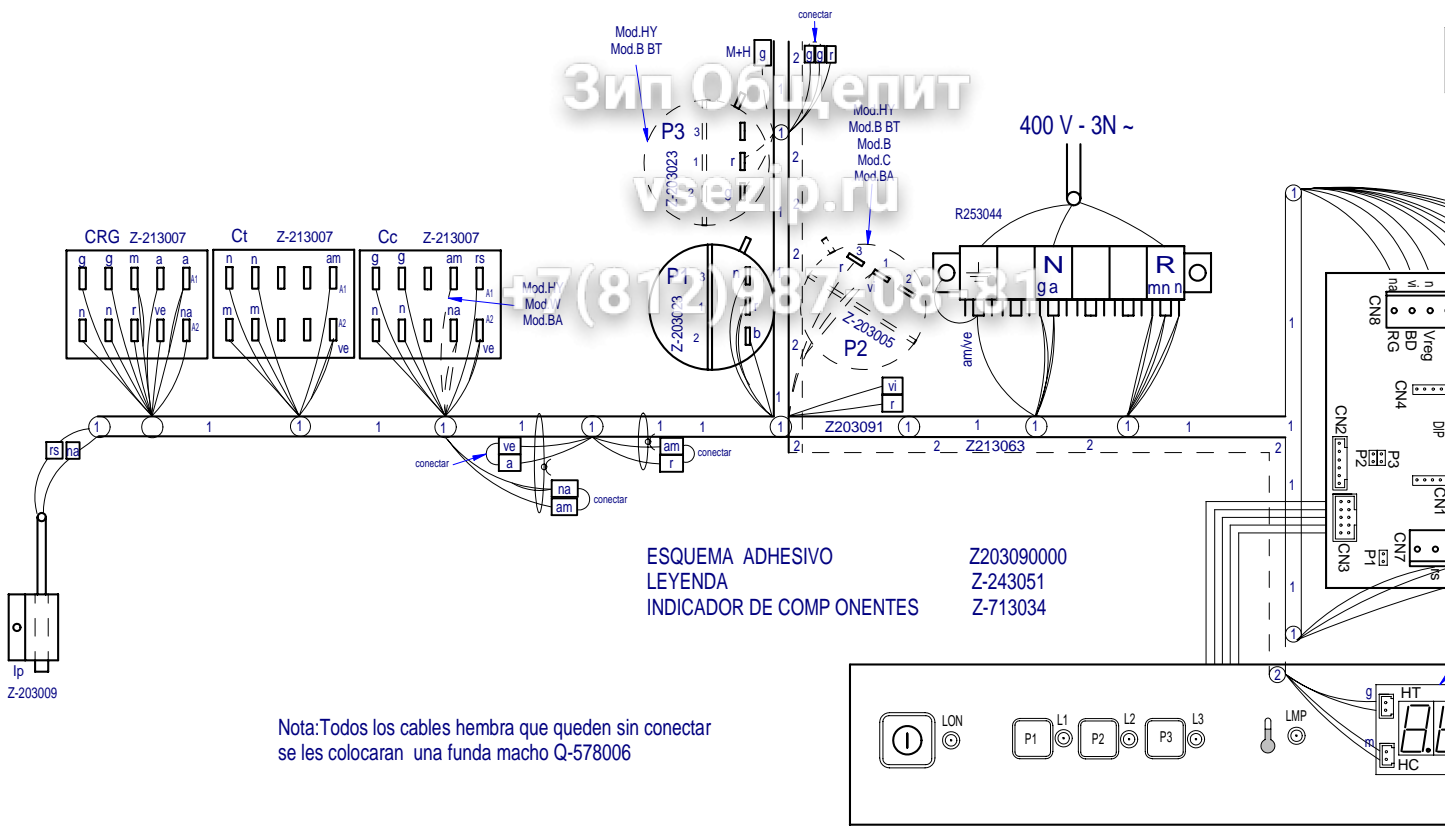

LEYENDA APERTURA FRONTAL

	ESPAÑOL	FRANÇAIS	ENGLISH	DEUTSCH
BD	Bomba desagüe	Pompe de vidage	Drain pump	Abflußpumpe
C 1/2/3	Condensador	Condensateur	Condenser	Kondensator
CMB	Contactora bomba lavado	Contacteur pompe lavage	Wash pump contactor	Kontaktschütz Waschpumpe
Cc 1/2	Contactora calentamiento calderin	Contacteur chauff. surchauffeur	Boiler heating contactor	Kontaktschütz Boilerheizung
Ct	Contactora calentamiento tanque	Contacteur chauffage cuve	Tank heating contactor	Kontaktschütz Heizung Tank
CP	Rele puerta	Relais porte	Door relay	Türrelais
Ds.Det.	Dosificador detergente	Dosueur de detergent	Detergent doser	Dosierer Spülmittel
E.B	Electrobomba de presion	Electropompe de pression	Electric pressure pump	Elektro-Drucksteigerungspumpe
IG	Interruptor general	Interrupteur general	Main switch	Hauptschalter
IP	Micro puerta	Micro porte	Door microswitch	Mikroschalter Tür
L1	Piloto de encendido	Voyant fonctionnement	Operation light	Betriebsanzeigelampe
L2	Piloto marcha	Voyant demarrage	Start light	Startanzeigelampe
L3	Piloto maquina preparada	Voyant machine prêt	Light machine ready	Betriebsbereitschaftsanzeige
MBL	Bomba lavado	Pompe lavage	Wash pump	Waschpumpe
M	Motor programador	Moteur du programmeur	Motor programmer	Motor Programmiervorrichtung
M Av. R	Motor program. avance rapido	Moteur du progr.avance rapide	Motor program. rapid advance	Motor Programmiervorrich. so
M1	Micro programador marcha	Micro du programm. de marche	Micro programmer on	Motor Programmiervorrich. Be
M2	Micro programador lavado	Micro du programm. de lavage	Micro programmer wash	Motor Programmiervorrich. W
M3	Micro programador aclarado	Micro du programm. de rinçage	Micro programmer on	Motor Programmiervorrich. Sp
M4	Micro programador Termo-stop	Micro du programm. Thermo-stop	Micro programmer Thermo-stop	Motor Programmiervorrich. Th
M5	Micro programador avance	Micro du programm. avance	Micro programmer advance	Motor Programmiervorrich. V
P, P1, P5	Presostato	Pressostat	Pressure switch	Druckwächter
P2, P3, P4	Presostato limitador	Pressostat de sécurité	Hi-limit pressure switch	Begrenzer Druckwächter
RC	Resistencia calderin	Resistance surchauffeur	Boiler heating element	Heizwiderstand Boiler
RT	Resistencia tanque	Resistance cuve	Tank heater	Heizwiderstand Tank
Tt	Termostato tanque	Thermostat de cuve	Tank thermostat	Thermostat Tank
TC	Termostato calderin	Thermostat surchauffeur	Boiler thermostat	Thermostat kessel
TSC	Limitador calderin	Limiteur surchauffeur	Boiler Hi-limit	Begrenzer Boiler
TSTP	Termostato termo-stop	Thermostat Thermo-stop	Thermo-stop Thermostat	Thermostat Thermo-stop
V	Electrovalvula llenado y aclarado	Electrovan. remplissage rinçage	Fill and rinse valve	Elektroventil Füllen und Spülen
COLOR	COLORES	COULEURS	COLOUR	FARBEN
a =	Azul	Bleu	Blue	Blau
am =	Amarillo	Jaune	Yellow	Gelb
am/ve =	Amarillo/verde	Jaune / vert	Yellow / green	Gelb/grün
b =	Blanco	Blanc	White	Weiß
g =	Gris	Gris	Grey	Grau
m =	Marrón	Marron	Brown	Braun
n =	Negro	Noir	Black	Schwarz
na =	Naranja	Orange	Orange	Orange
r =	Rojo	Rouge	Red	Rot
rs =	Rosa	Rose	Pink	Rosa
ve =	Verde	Vert	Green	Grün
vi =	Violeta	Violet	Purple	Violett